

## LM26NV SOT-23, $\pm 3^{\circ}\text{C}$ Accurate, Factory Preset Thermostat (LM26 without $V_{\text{TEMP}}$ output)

Check for Samples: [LM26NV](#)

### FEATURES

- Internal Comparator with Pin Programmable  $2^{\circ}\text{C}$  or  $10^{\circ}\text{C}$  Hysteresis
- No External Components Required
- Open Drain or Push-Pull Digital Output; Supports CMOS Logic Levels
- Internal Temperature Sensor
- Internal Voltage Reference and DAC for Trip-Point Setting
- Currently Available in 5-Pin SOT-23 Plastic Package
- Excellent Power Supply Noise Rejection

### APPLICATIONS

- Microprocessor Thermal Management
- Appliances
- Portable Battery Powered Systems
- Fan Control
- Industrial Process Control
- HVAC Systems
- Remote Temperature Sensing
- Electronic System Protection

### KEY SPECIFICATIONS

- Power Supply Voltage: 2.7V to 5.5 V
- Power Supply Current:
  - $40\mu\text{A}(\text{max})$
  - $20\mu\text{A}(\text{typ})$
- Hysteresis Temperature:  $2^{\circ}\text{C}$  or  $10^{\circ}\text{C}(\text{typ})$

### DESCRIPTION

The LM26NV is a precision, single digital-output, low-power thermostat comprised of an internal reference, DAC, temperature sensor and comparator. Utilizing factory programming, it can be manufactured with different trip points as well as different digital output functionality. The trip point ( $T_{\text{OS}}$ ) can be preset at the factory to any temperature in the range of  $-55^{\circ}\text{C}$  to  $+110^{\circ}\text{C}$  in  $1^{\circ}\text{C}$  increments. The LM26NV has one digital output ( $\text{OS}/\overline{\text{OS}}/\text{US}/\overline{\text{US}}$ ) and one digital input (HYST). The digital output stage can be preset as either open-drain or push-pull. In addition, it can be factory programmed to be active HIGH or LOW. The digital output can be factory programmed to indicate an over temperature shutdown event ( $\text{OS}$  or  $\overline{\text{OS}}$ ) or an under temperature shutdown event ( $\text{US}$  or  $\overline{\text{US}}$ ). When preset as an overtemperature shutdown ( $\overline{\text{OS}}$ ), it will go LOW to indicate that the die temperature is over the internally preset  $T_{\text{OS}}$  and go HIGH when the temperature goes below ( $T_{\text{OS}} - T_{\text{HYST}}$ ). Similarly, when preprogrammed as an undertemperature shutdown ( $\text{US}$ ) it will go HIGH to indicate that the temperature is below  $T_{\text{US}}$  and go LOW when the temperature is above ( $T_{\text{US}} + T_{\text{HYST}}$ ). The typical hysteresis,  $T_{\text{HYST}}$ , can be set to  $2^{\circ}\text{C}$  or  $10^{\circ}\text{C}$  and is controlled by the state of the HYST pin.

Available parts are detailed in the ordering information. For other part options, contact a Texas Instruments Distributor or Sales Representative for information on minimum order qualification. The LM26NV is currently available in a 5-lead SOT-23 package.

**Table 1. Temperature Trip Point Accuracy**

Temperature Range	LM26NV
$-55^{\circ}\text{C}$ to $+110^{\circ}\text{C}$	$\pm 3^{\circ}\text{C}$ (max)
$+120^{\circ}\text{C}$	$\pm 4^{\circ}\text{C}$ (max)



Please be aware that an important notice concerning availability, standard warranty, and use in critical applications of Texas Instruments semiconductor products and disclaimers thereto appears at the end of this data sheet.

All trademarks are the property of their respective owners.

## Connection Diagram

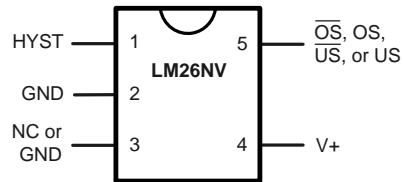

**Figure 1. 5-Lead SOT-23**  
See DBV Package

### PIN DESCRIPTIONS

Pin Number	Pin Name	Function	Connection
1	HYST	Hysteresis control, digital input	GND for 10°C or V <sup>+</sup> for 2°C
2	GND	Ground, connected to the back side of the die through lead frame.	System GND
3	NC	Not Connected Inside Part	Ground or No Connect
4	V <sup>+</sup>	Supply input	2.7V to 5.5V with a 0.1μF bypass capacitor. For PSRR information see <i>Section Titled NOISE CONSIDERATIONS</i> .
5 <sup>(1)</sup>	OS-bar	Overtemperature Shutdown open-drain active low thermostat digital output	Controller interrupt, system or power supply shutdown; pull-up resistor ≥ 10kΩ
	OS	Overtemperature Shutdown push-pull active high thermostat digital output	Controller interrupt, system or power supply shutdown
	US-bar	Undertemperature Shutdown open-drain active low thermostat digital output	System or power supply shutdown; pull-up resistor ≥ 10kΩ
	US	Undertemperature Shutdown push-pull active high thermostat digital output	System or power supply shutdown

(1) Pin 5 functionality and trip point setting are programmed during LM26NV manufacture.

## LM26CIM5-YPE Simplified Block Diagram and Connection Diagram

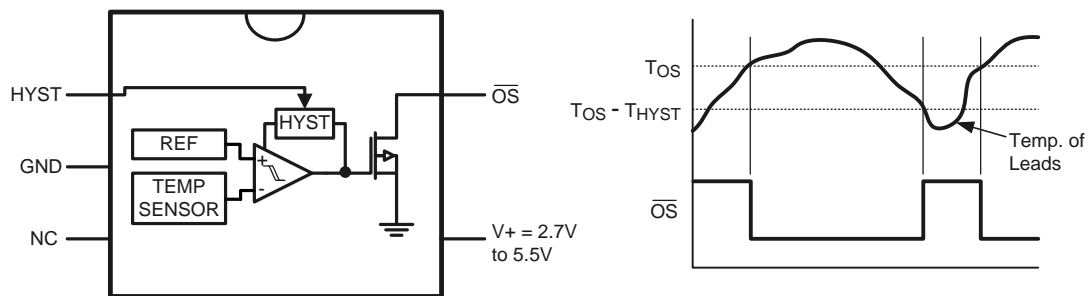

HYST = GND for 10°C Hysteresis  
HYST = V<sup>+</sup> for 2°C Hysteresis

The LM26CIM5-YPE has a fixed trip point of 115°C. For other trip point and output function availability, please see ordering information or contact Texas Instruments.

**Figure 2.**



These devices have limited built-in ESD protection. The leads should be shorted together or the device placed in conductive foam during storage or handling to prevent electrostatic damage to the MOS gates.

### Absolute Maximum Ratings <sup>(1)</sup>

Input Voltage		6.0V
Input Current at any pin <sup>(2)</sup>		5mA
Package Input Current <sup>(2)</sup>		20mA
Package Dissipation at $T_A = 25^\circ\text{C}$ <sup>(3)</sup>		500mW
Soldering Information <sup>(4)</sup>		
SOT-23 Package	Vapor Phase (60 seconds)	215°C
	Infrared (15 seconds)	220°C
Storage Temperature		-65°C to +150°C
ESD Susceptibility <sup>(5)</sup>	Human Body Model	2500V
	Machine Model	250V

- (1) Absolute Maximum Ratings indicate limits beyond which damage to the device may occur. Operating Ratings indicate conditions for which the device is functional, but do not ensure specific performance limits. For ensured specifications and test conditions, see the Electrical Characteristics. The ensured specifications apply only for the test conditions listed. Some performance characteristics may degrade when the device is not operated under the listed test conditions.
- (2) When the input voltage ( $V_I$ ) at any pin exceeds the power supply ( $V_I < \text{GND}$  or  $V_I > V^+$ ), the current at that pin should be limited to 5mA. The 20mA maximum package input current rating limits the number of pins that can safely exceed the power supplies with an input current of 5mA to four. Under normal operating conditions the maximum current that pins 2, 4 or 5 can handle is limited to 5mA each.
- (3) The maximum power dissipation must be derated at elevated temperatures and is dictated by  $T_{J\text{max}}$  (maximum junction temperature),  $\theta_{JA}$  (junction to ambient thermal resistance) and  $T_A$  (ambient temperature). The maximum allowable power dissipation at any temperature is  $P_D = (T_{J\text{max}} - T_A) / \theta_{JA}$  or the number given in the Absolute Maximum Ratings, whichever is lower. For this device,  $T_{J\text{max}} = 150^\circ\text{C}$ . For this device the typical thermal resistance ( $\theta_{JA}$ ) of the different package types when board mounted follow:
- (4) See the URL "<http://www.ti.com/packaging>" for other recommendations and methods of soldering surface mount devices.
- (5) The human body model is a 100pF capacitor discharge through a 1.5k $\Omega$  resistor into each pin. The machine model is a 200pF capacitor discharged directly into each pin.

### Operating Ratings <sup>(1)</sup>

Specified Temperature Range	$T_{\text{MIN}} \leq T_A \leq T_{\text{MAX}}$
LM26NV	$-55^\circ\text{C} \leq T_A \leq +125^\circ\text{C}$
Positive Supply Voltage ( $V^+$ )	+2.7V to +5.5V
Maximum $V_{\text{OUT}}$	+5.5V

- (1) Absolute Maximum Ratings indicate limits beyond which damage to the device may occur. Operating Ratings indicate conditions for which the device is functional, but do not ensure specific performance limits. For ensured specifications and test conditions, see the Electrical Characteristics. The ensured specifications apply only for the test conditions listed. Some performance characteristics may degrade when the device is not operated under the listed test conditions.

## LM26NV Electrical Characteristics

The following specifications apply for  $V^+ = 2.7V_{DC}$  to  $5.5V_{DC}$ , and  $V_{TEMP}$  load current =  $0\mu A$  unless otherwise specified.

**Boldface limits apply for  $T_A = T_J = T_{MIN}$  to  $T_{MAX}$ ; all other limits  $T_A = T_J = 25^\circ C$  unless otherwise specified.**

Symbol	Parameter	Conditions	Typical <sup>(1)</sup>	LM26NV Limits <sup>(2)</sup>	Units (Limits)
<b>Temperature Sensor</b>					
	Trip Point Accuracy (Includes $V_{REF}$ , DAC, Comparator Offset, and Temperature Sensitivity errors)	$-55^\circ C \leq T_A \leq +110^\circ C$		$\pm 3$	$^\circ C$ (max)
		$+120^\circ C$		$\pm 4$	$^\circ C$ (max)
	Trip Point Hysteresis	HYST = GND	11		$^\circ C$
		HYST = $V^+$	2		$^\circ C$
$I_S$	Supply Current		16	20 <b>40</b>	$\mu A$ (max) $\mu A$ (max)
<b>Digital Output and Input</b>					
$I_{OUT("1")}$	Logical "1" Output Leakage Current <sup>(3)</sup>	$V^+ = +5.0V$	0.001	1	$\mu A$ (max)
$V_{OUT("0")}$	Logical "0" Output Voltage	$I_{OUT} = +1.2mA$ and $V^+ \geq 2.7V$ ; $I_{OUT} = +3.2mA$ and $V^+ \geq 4.5V$ ; <sup>(4)</sup>		<b>0.4</b>	V (max)
$V_{OUT("1")}$	Logical "1" Push-Pull Output Voltage	$I_{SOURCE} = 500\mu A$ , $V^+ \geq 2.7V$		<b><math>0.8 \times V^+</math></b>	V (min)
		$I_{SOURCE} = 800\mu A$ , $V^+ \geq 4.5V$		<b><math>V^+ - 1.5</math></b>	V (min)
$V_{IH}$	HYST Input Logical "1" Threshold Voltage			<b><math>0.8 \times V^+</math></b>	V (min)
$V_{IL}$	HYST Input Logical "0" Threshold Voltage			<b><math>0.2 \times V^+</math></b>	V (max)

(1) Typicals are at  $T_J = T_A = 25^\circ C$  and represent most likely parametric norm.

(2) Limits are ensured to AOQL (Average Outgoing Quality Level).

(3) The  $1\mu A$  limit is based on a testing limitation and does not reflect the actual performance of the part. Expect to see a doubling of the current for every  $15^\circ C$  increase in temperature. For example, the  $1nA$  typical current at  $25^\circ C$  would increase to  $16nA$  at  $85^\circ C$ .

(4) Care should be taken to include the effects of self heating when setting the maximum output load current. The power dissipation of the LM26NV would increase by  $1.28mW$  when  $I_{OUT} = 3.2mA$  and  $V_{OUT} = 0.4V$ . With a thermal resistance of  $250^\circ C/W$ , this power dissipation would cause an increase in the die temperature of about  $0.32^\circ C$  due to self heating. Self heating is not included in the trip point accuracy specification.

Package Type	$\theta_{JA}$
SOT-23, DBV	$250^\circ C/W$

## Part Number Template

The series of characters labeled "xyz" in the part number LM26CIM5-xyz, describe the set point value and the function of the output. The character at "x" and "y" define the set point temperature (at which the digital output will go active). The "z" character defines the type and function of the digital output. These place holders are defined in the following tables.

The place holders xy describe the set point temperature as shown in the following table.

x (10x)	y (1x)	Temperature ( $^\circ C$ )
A	-	-5
B	-	-4
C	-	-3
D	-	-2
E	-	-1
F	-	-0
H	H	0
J	J	1
K	K	2
L	L	3

x (10x)	y (1x)	Temperature (°C)
N	N	4
P	P	5
R	R	6
S	S	7
T	T	8
V	V	9
X	-	10
Y	-	11
Z	-	12

The value of z describes the assignment/function of the output as shown in the following table:

Active-Low/High	Open-Drain/ Push-Pull	OS/US	Value of z	Digital Output Function
0	0	0	E	Active-Low, Open-Drain, $\overline{OS}$ output
0	0	1	F	Active-Low, Open-Drain, $\overline{US}$ output
1	1	0	G	Active-High, Push-Pull, OS output
1	1	1	H	Active-High, Push-Pull, US output

**EXAMPLE:**

- The part number LM26CIM5-YPE has  $T_{OS} = 115^{\circ}\text{C}$ , and has an active-low open-drain overtemperature shutdown output. The "Y" represents the tens value "11", the "P" represents the ones value "5", and the "E" means that the output will be an active-low, open-drain, over-temperature output.

Many active-high open-drain and active-low push-pull options are available, please contact Texas Instruments for more information.

## FUNCTIONAL DESCRIPTION

### LM26NV OPTIONS

The LM26NV can be factory programmed to have a trip point anywhere in the range of  $-55^{\circ}\text{C}$  to  $+110^{\circ}\text{C}$ . It is also available in any of four output options, as indicated by the last letter in the part number.

#### Output Pin Options Block Diagrams

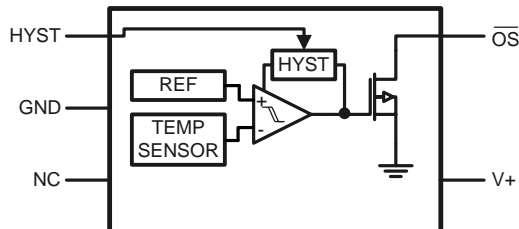

The "E" in "LM26CIM5 - \_\_ E" indicates that the digital output is Active-Low Open-Drain and will trip as temperature is rising (OS)

**Figure 3. LM26CIM5 - \_\_ E**

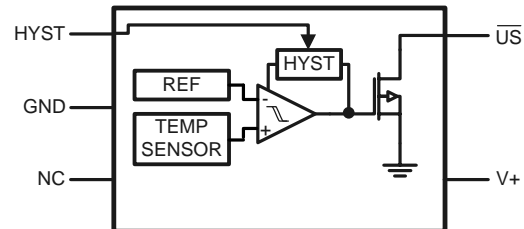

The "F" in "LM26CIM5 - \_\_ F" indicates that the digital output is Active-Low Open-Drain and will trip as temperature is falling ( $\overline{\text{US}}$ )

**Figure 4. LM26CIM5 - \_\_ F**

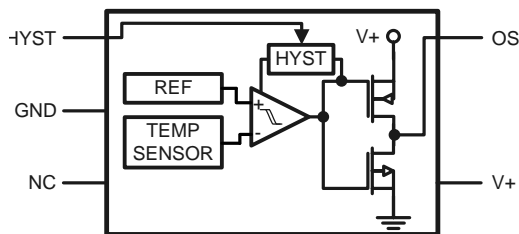

The "G" in "LM26CIM5 - \_\_ G" indicates that the digital output is Active-High Push-Pull and will trip as temperature is rising (OS)

**Figure 5. LM26CIM5 - \_\_ G**

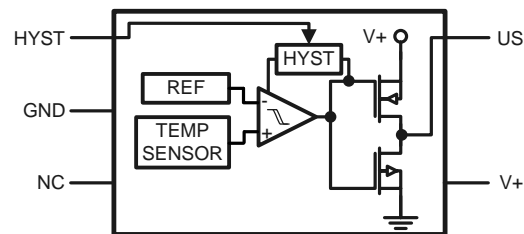

The "H" in "LM26CIM5 - \_\_ H" indicates that the digital output is Active-High Push-Pull and will trip as temperature is falling (US)

**Figure 6. LM26CIM5 - \_\_ H**

### Applications Hints

#### NOISE CONSIDERATIONS

The LM26NV has excellent power supply noise rejection. Listed below is a variety of signals used to test the LM26NV power supply rejection. False triggering of the output was not observed when these signals were coupled into the V+ pin of the LM26NV.

- Square Wave 400kHz, 1Vp-p
- Square Wave 2kHz, 200mVp-p
- Sine Wave 100Hz to 1MHz, 200mVp-p

Testing was done while maintaining the temperature of the LM26NV one degree centigrade away from the trip point with the output not activated.

## MOUNTING CONSIDERATIONS

The LM26NV can be applied easily in the same way as other integrated-circuit temperature sensors. It can be glued or cemented to a surface. The temperature that the LM26NV is sensing will be within about +0.06°C of the surface temperature to which the LM26NV's leads are attached to.

This presumes that the ambient air temperature is almost the same as the surface temperature; if the air temperature were much higher or lower than the surface temperature, the actual temperature measured would be at an intermediate temperature between the surface temperature and the air temperature.

To ensure good thermal conductivity, the backside of the LM26NV die is directly attached to the GND pin (pin 2). The temperatures of the lands and traces to the other leads of the LM26NV will also affect the temperature that is being sensed.

Alternatively, the LM26NV can be mounted inside a sealed-end metal tube, and can then be dipped into a bath or screwed into a threaded hole in a tank. As with any IC, the LM26NV and accompanying wiring and circuits must be kept insulated and dry, to avoid leakage and corrosion. This is especially true if the circuit may operate at cold temperatures where condensation can occur. Printed-circuit coatings and varnishes such as Humiseal and epoxy paints or dips are often used to ensure that moisture cannot corrode the LM26NV or its connections.

The junction to ambient thermal resistance ( $\theta_{JA}$ ) is the parameter used to calculate the rise of a part's junction temperature due to its power dissipation. For the LM26NV the equation used to calculate the rise in the die junction temperature is as follows:

$$T_J = T_A + \theta_{JA}(V^+I_Q + V_{DO}I_{DO})$$

where

- $T_A$  is the ambient temperature
  - $V^+$  is the power supply voltage
  - $I_Q$  is the quiescent current
  - $V_{DO}$  is the voltage on the digital output
  - $I_{DO}$  is the load current on the digital output
- (1)

Table 2 summarizes the thermal resistance for different conditions and the rise in die temperature of the LM26NV and a 10k pull-up resistor on an open-drain digital output with a 5.5V power supply.

**Table 2. Thermal resistance ( $\theta_{JA}$ ) and temperature rise due to self heating ( $T_J - T_A$ )**

	SOT-23 no heat sink		SOT-23 small heat sink	
	$\theta_{JA}$ (°C/W)	$T_J - T_A$ (°C)	$\theta_{JA}$ (°C/W)	$T_J - T_A$ (°C)
Still Air	250	0.11	TBD	TBD
Moving Air	TBD	TBD	TBD	TBD

## Typical Applications

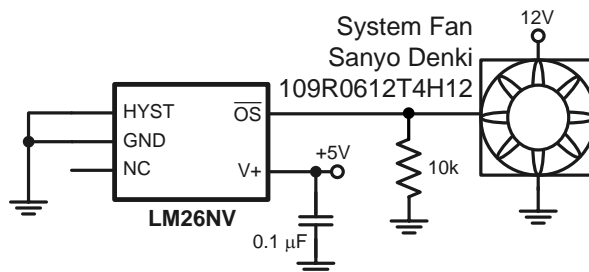

The fan's control pin has an internal pull-up. The 10 kOhm pull-down sets a slow fan speed. When the output of the LM26NV goes low, the fan will speed up.

**Figure 7. Two Speed Fan Speed Control**

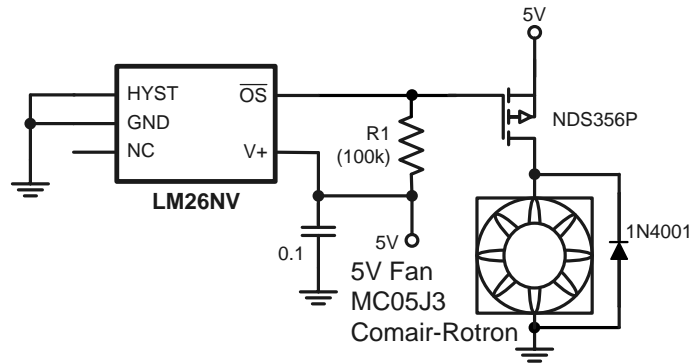

The LM26NV switches the fan on when the measured temperature exceeds the trip temperature.

**Figure 8. Fan High Side Drive**

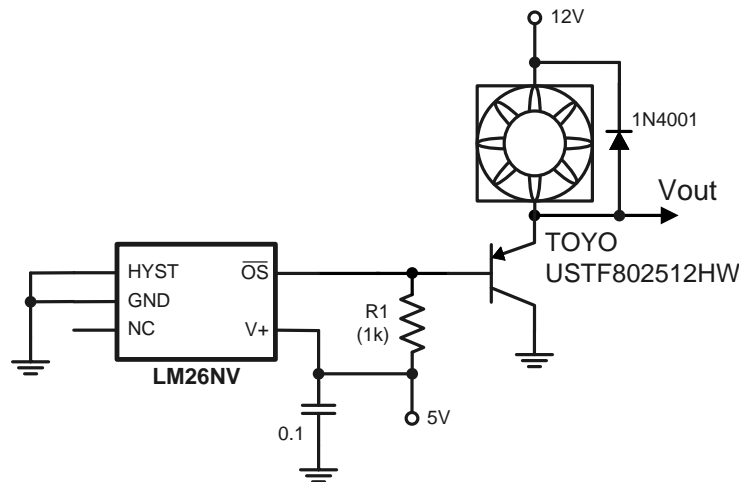

The LM26LV sinks causes the switch to sink the fan current when the measured temperature exceeds the trip temperature.

**Figure 9. Fan Low Side Drive**

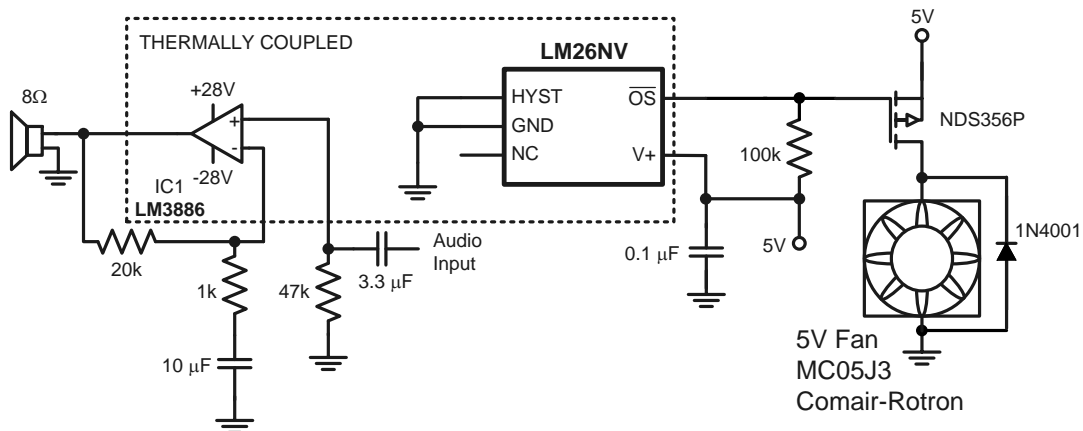

By thermally coupling the LM26NV to the audio power amplifier, the LM26NV safeguards the amplifier from overheating, turning on the fan when its temperature exceeds the trip temperature.

**Figure 10. Audio Power Amplifier Thermal Protection**



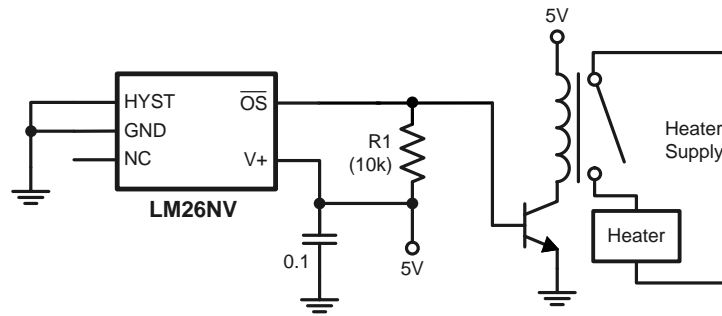



When the measured temperature is below the trip temperature of the LM26NV, the  $\overline{OS}$  output will be high, causing the switch and relay to close. When the temperature exceeds the trip point,  $\overline{OS}$  goes low and shuts off the relay and heater.

**Figure 11. Simple Thermostat**

## REVISION HISTORY

Changes from Revision A (March 2013) to Revision B	Page
• Changed layout of National Data Sheet to TI format .....	<a href="#">9</a>

**PACKAGING INFORMATION**

Orderable Device	Status (1)	Package Type	Package Drawing	Pins	Package Qty	Eco Plan (2)	Lead finish/ Ball material (6)	MSL Peak Temp (3)	Op Temp (°C)	Device Marking (4/5)	Samples
LM26CIM5-YPE/NOPB	ACTIVE	SOT-23	DBV	5	1000	RoHS & Green	SN	Level-1-260C-UNLIM	-55 to 125	TYPE	
LM26CIM5X-YPE/NOPB	ACTIVE	SOT-23	DBV	5	3000	RoHS & Green	SN	Level-1-260C-UNLIM	-55 to 125	TYPE	

(1) The marketing status values are defined as follows:

**ACTIVE:** Product device recommended for new designs.

**LIFEBUY:** TI has announced that the device will be discontinued, and a lifetime-buy period is in effect.

**NRND:** Not recommended for new designs. Device is in production to support existing customers, but TI does not recommend using this part in a new design.

**PREVIEW:** Device has been announced but is not in production. Samples may or may not be available.

**OBsolete:** TI has discontinued the production of the device.

(2) **RoHS:** TI defines "RoHS" to mean semiconductor products that are compliant with the current EU RoHS requirements for all 10 RoHS substances, including the requirement that RoHS substance do not exceed 0.1% by weight in homogeneous materials. Where designed to be soldered at high temperatures, "RoHS" products are suitable for use in specified lead-free processes. TI may reference these types of products as "Pb-Free".

**RoHS Exempt:** TI defines "RoHS Exempt" to mean products that contain lead but are compliant with EU RoHS pursuant to a specific EU RoHS exemption.

**Green:** TI defines "Green" to mean the content of Chlorine (Cl) and Bromine (Br) based flame retardants meet JS709B low halogen requirements of <=1000ppm threshold. Antimony trioxide based flame retardants must also meet the <=1000ppm threshold requirement.

(3) MSL, Peak Temp. - The Moisture Sensitivity Level rating according to the JEDEC industry standard classifications, and peak solder temperature.

(4) There may be additional marking, which relates to the logo, the lot trace code information, or the environmental category on the device.

(5) Multiple Device Markings will be inside parentheses. Only one Device Marking contained in parentheses and separated by a "~" will appear on a device. If a line is indented then it is a continuation of the previous line and the two combined represent the entire Device Marking for that device.

(6) Lead finish/Ball material - Orderable Devices may have multiple material finish options. Finish options are separated by a vertical ruled line. Lead finish/Ball material values may wrap to two lines if the finish value exceeds the maximum column width.

**Important Information and Disclaimer:**The information provided on this page represents TI's knowledge and belief as of the date that it is provided. TI bases its knowledge and belief on information provided by third parties, and makes no representation or warranty as to the accuracy of such information. Efforts are underway to better integrate information from third parties. TI has taken and continues to take reasonable steps to provide representative and accurate information but may not have conducted destructive testing or chemical analysis on incoming materials and chemicals. TI and TI suppliers consider certain information to be proprietary, and thus CAS numbers and other limited information may not be available for release.

In no event shall TI's liability arising out of such information exceed the total purchase price of the TI part(s) at issue in this document sold by TI to Customer on an annual basis.



## TAPE AND REEL INFORMATION



### QUADRANT ASSIGNMENTS FOR PIN 1 ORIENTATION IN TAPE



\*All dimensions are nominal

Device	Package Type	Package Drawing	Pins	SPQ	Reel Diameter (mm)	Reel Width W1 (mm)	A0 (mm)	B0 (mm)	K0 (mm)	P1 (mm)	W (mm)	Pin1 Quadrant
LM26CIM5-YPE/NOPB	SOT-23	DBV	5	1000	179.0	8.4	3.2	3.2	1.4	4.0	8.0	Q3
LM26CIM5X-YPE/NOPB	SOT-23	DBV	5	3000	179.0	8.4	3.2	3.2	1.4	4.0	8.0	Q3

**TAPE AND REEL BOX DIMENSIONS**

\*All dimensions are nominal

Device	Package Type	Package Drawing	Pins	SPQ	Length (mm)	Width (mm)	Height (mm)
LM26CIM5-YPE/NOPB	SOT-23	DBV	5	1000	200.0	183.0	25.0
LM26CIM5X-YPE/NOPB	SOT-23	DBV	5	3000	200.0	183.0	25.0

DBV0005A



# PACKAGE OUTLINE

SOT-23 - 1.45 mm max height

SMALL OUTLINE TRANSISTOR

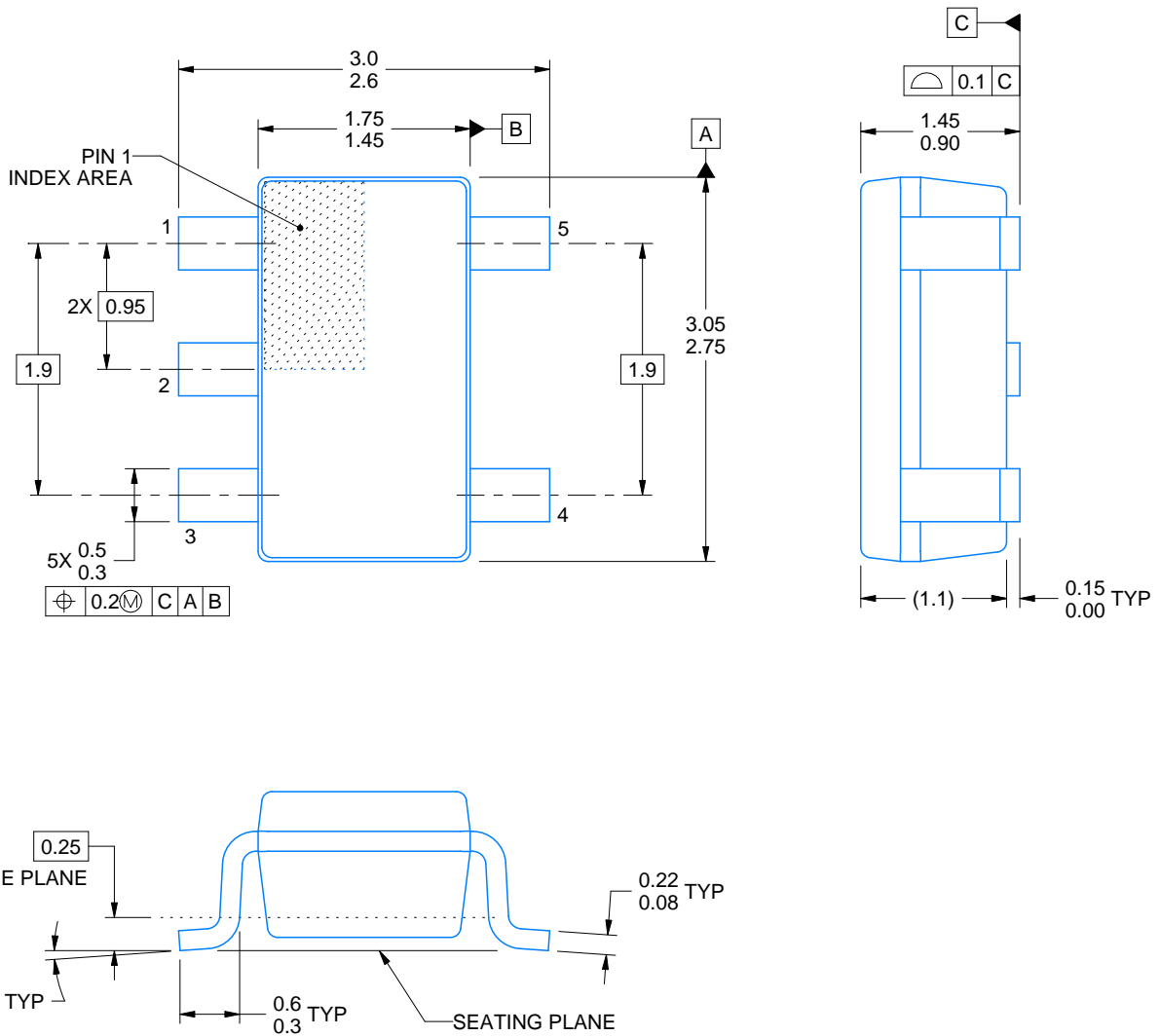

4214839/E 09/2019

## NOTES:

1. All linear dimensions are in millimeters. Any dimensions in parenthesis are for reference only. Dimensioning and tolerancing per ASME Y14.5M.
2. This drawing is subject to change without notice.
3. Reference JEDEC MO-178.
4. Body dimensions do not include mold flash, protrusions, or gate burrs. Mold flash, protrusions, or gate burrs shall not exceed 0.15 mm per side.

# EXAMPLE BOARD LAYOUT

DBV0005A

SOT-23 - 1.45 mm max height

SMALL OUTLINE TRANSISTOR



LAND PATTERN EXAMPLE  
EXPOSED METAL SHOWN  
SCALE:15X



SOLDER MASK DETAILS

4214839/E 09/2019

NOTES: (continued)

- 5. Publication IPC-7351 may have alternate designs.
- 6. Solder mask tolerances between and around signal pads can vary based on board fabrication site.



# EXAMPLE STENCIL DESIGN

DBV0005A

SOT-23 - 1.45 mm max height

SMALL OUTLINE TRANSISTOR



SOLDER PASTE EXAMPLE  
BASED ON 0.125 mm THICK STENCIL  
SCALE:15X

4214839/E 09/2019

NOTES: (continued)

7. Laser cutting apertures with trapezoidal walls and rounded corners may offer better paste release. IPC-7525 may have alternate design recommendations.
8. Board assembly site may have different recommendations for stencil design.



# DBV0005A

# PACKAGE OUTLINE

## SOT-23 - 1.45 mm max height

SMALL OUTLINE TRANSISTOR



4214839/F 06/2021

### NOTES:

1. All linear dimensions are in millimeters. Any dimensions in parenthesis are for reference only. Dimensioning and tolerancing per ASME Y14.5M.
2. This drawing is subject to change without notice.
3. Reference JEDEC MO-178.
4. Body dimensions do not include mold flash, protrusions, or gate burrs. Mold flash, protrusions, or gate burrs shall not exceed 0.25 mm per side.

# EXAMPLE BOARD LAYOUT

DBV0005A

SOT-23 - 1.45 mm max height

SMALL OUTLINE TRANSISTOR



LAND PATTERN EXAMPLE  
EXPOSED METAL SHOWN  
SCALE:15X



SOLDER MASK DETAILS

4214839/F 06/2021

NOTES: (continued)

- 5. Publication IPC-7351 may have alternate designs.
- 6. Solder mask tolerances between and around signal pads can vary based on board fabrication site.

# EXAMPLE STENCIL DESIGN

DBV0005A

SOT-23 - 1.45 mm max height

SMALL OUTLINE TRANSISTOR



SOLDER PASTE EXAMPLE  
BASED ON 0.125 mm THICK STENCIL  
SCALE:15X

4214839/F 06/2021

NOTES: (continued)

7. Laser cutting apertures with trapezoidal walls and rounded corners may offer better paste release. IPC-7525 may have alternate design recommendations.
8. Board assembly site may have different recommendations for stencil design.

## IMPORTANT NOTICE AND DISCLAIMER

TI PROVIDES TECHNICAL AND RELIABILITY DATA (INCLUDING DATASHEETS), DESIGN RESOURCES (INCLUDING REFERENCE DESIGNS), APPLICATION OR OTHER DESIGN ADVICE, WEB TOOLS, SAFETY INFORMATION, AND OTHER RESOURCES "AS IS" AND WITH ALL FAULTS, AND DISCLAIMS ALL WARRANTIES, EXPRESS AND IMPLIED, INCLUDING WITHOUT LIMITATION ANY IMPLIED WARRANTIES OF MERCHANTABILITY, FITNESS FOR A PARTICULAR PURPOSE OR NON-INFRINGEMENT OF THIRD PARTY INTELLECTUAL PROPERTY RIGHTS.

These resources are intended for skilled developers designing with TI products. You are solely responsible for (1) selecting the appropriate TI products for your application, (2) designing, validating and testing your application, and (3) ensuring your application meets applicable standards, and any other safety, security, or other requirements. These resources are subject to change without notice. TI grants you permission to use these resources only for development of an application that uses the TI products described in the resource. Other reproduction and display of these resources is prohibited. No license is granted to any other TI intellectual property right or to any third party intellectual property right. TI disclaims responsibility for, and you will fully indemnify TI and its representatives against, any claims, damages, costs, losses, and liabilities arising out of your use of these resources.

TI's products are provided subject to TI's Terms of Sale (<https://www.ti.com/legal/termsofsale.html>) or other applicable terms available either on [ti.com](https://www.ti.com) or provided in conjunction with such TI products. TI's provision of these resources does not expand or otherwise alter TI's applicable warranties or warranty disclaimers for TI products.

Mailing Address: Texas Instruments, Post Office Box 655303, Dallas, Texas 75265  
Copyright © 2021, Texas Instruments Incorporated