

**RoHS
Compliant
Drawing For
Reference Only**

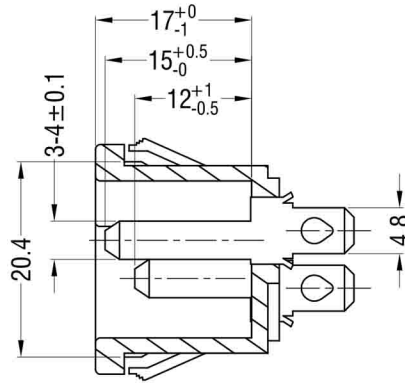

SECTION A-A

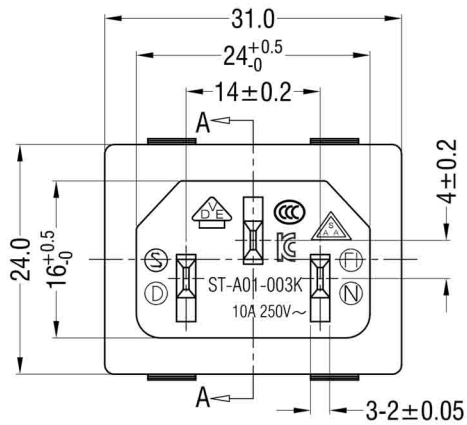
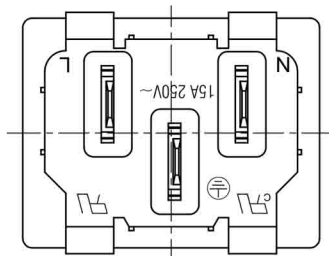
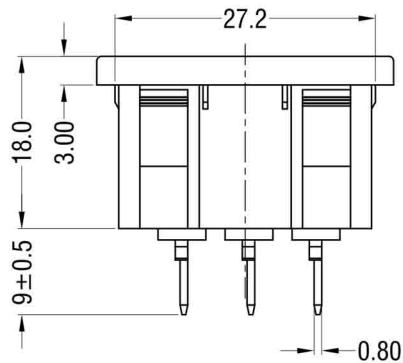

SPEC:

A. Material:

1. Housing: PA66
2. Terminal: COPPER ALLOY, TIN PLATED

B. Electrical Characteristics:

1. Rating: 15A 250V~ (UL, CUL)
10A 250V~ (CCC, VDE, SEMKO, NEMKO, FIMKO, DEMKO, SAA, KC)
2. Electric Strength: AC 2,000 V FOR ONE MINUTE
3. Insulation Resistance: 100MΩ MIN, AT 500V DC

C. Approvals:

UL, CUL, CCC, VDE, SEMKO, NEMKO, FIMKO, DEMKO, SAA, KC

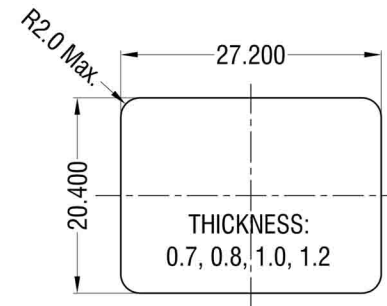

PANEL CUT-OUT

Technical requirement :

1. This product should meet EU RoHS related requirement.
2. The surface of plastic part should be without any crackle such as burr, lack, and so on phenomenon.
3. The surface of metal part should be without any defect such as scour, nick, oxidation and plating problem.
4. The electronic performance should be the same as spec.

Common Tolerance	
DIMENSION:	ANGLE:
0.0 ±0.3	±3°
0.00 ±0.20	
0.000 ±0.100	

DCI DRAGON CITY INDUSTRIES LIMITED

Design	K.W Law	Remark		Scale	
Drawing	W.K Yeung	Remark		Material	
Check	K.L Wong	Remark		Drawing No.	B110071010
Approval	K.W Chan	Remark		Sheet	

Item Name AC SOCKET

Tolerance :

Item No. AS-224K-27-UL-EN (ST-A01-003K)

Unit : mm