

RoHS Compliant
Drawing For Reference Only

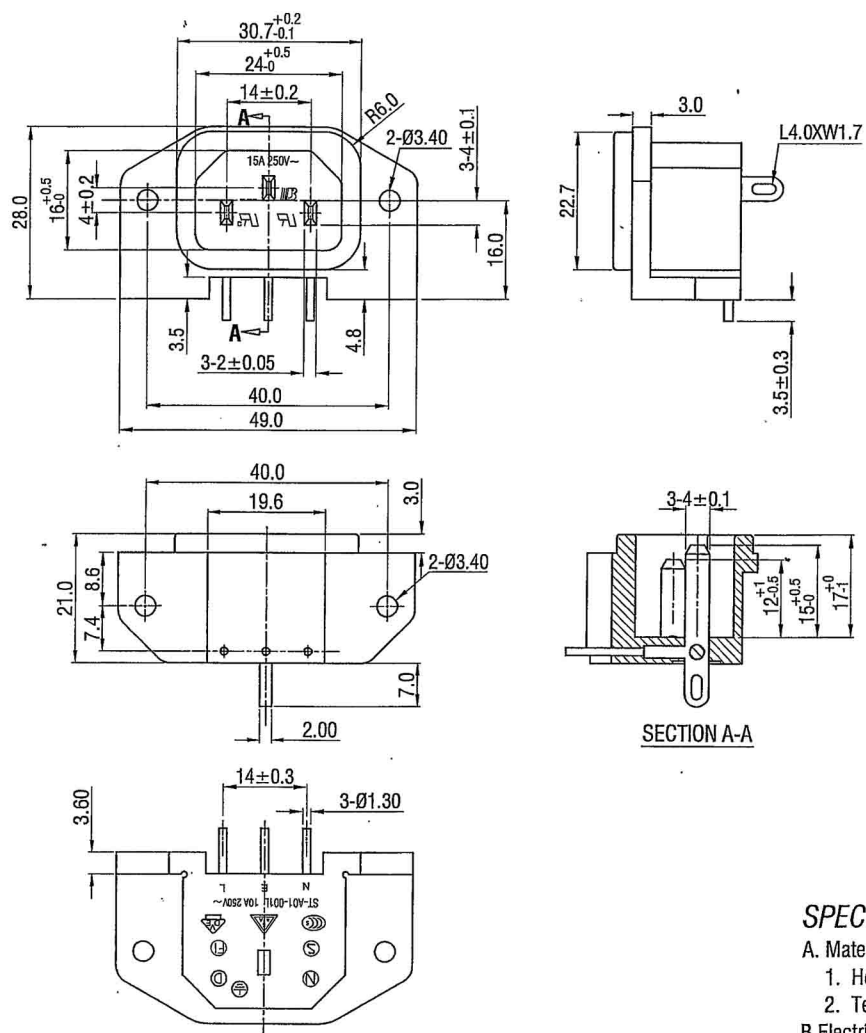

项次	名称	料号	材质	规格	用量	备注
A	胶壳	—	PBT+G/F30%	黑色	—	
B	长插销	A01-Y4L	H62黄铜	镀锡	1PCS	镀锡厚度3um
C	短插销	A01-Y4S	H62黄铜	镀锡	2PCS	镀锡厚度3um

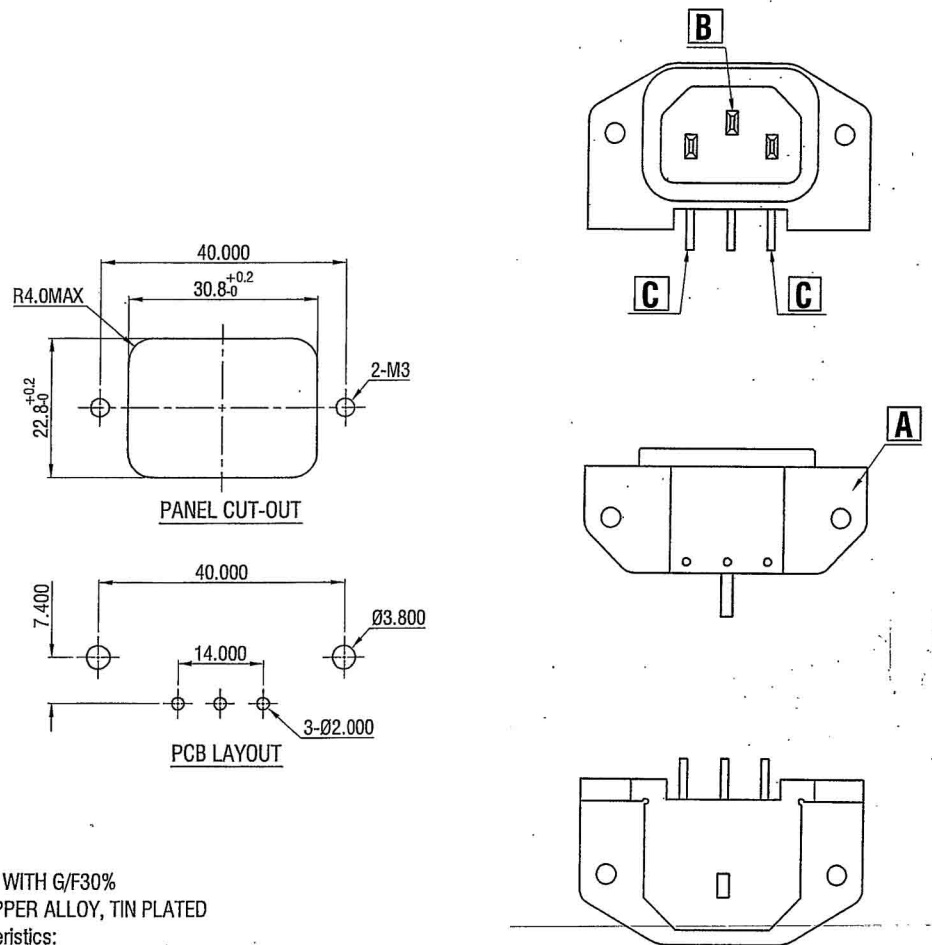

Technical requirement :

- This product should meet EU RoHS related requirement.
- The surface of plastic part should be without any crackle such as burr,lack,and so on phenomenon.
- The surface of metal part should be without any defect such as scour,nick,oxidation and plating problem.
- The electronic performance should be the same as spec.

SPEC:

A. Material:

- Housing: PBT WITH G/F30%
- Terminal: COPPER ALLOY, TIN PLATED

B. Electrical Characteristics:

- Rating: 15A 250V~ (UL,CUL)
10A 250V~ (CCC,VDE,SEMKO,NEMKO,FIMKO,DEMKO,SAA)
- Electric Strength: AC 2,000 V FOR ONE MINUTE
- Insulation Resistance: 100MΩ MIN, AT 500V DC

C. Approvals:
UL, CUL, CCC, VDE, SEMKO, NEMKO, FIMKO, DEMKO, SAA

Common Tolerance	DIMENSION:	ANGLE:
0.0	±0.3	±3°
0.00	±0.20	
0.000	±0.100	

DCI DRAGON CITY INDUSTRIES LIMITED

Item Name	AC SOCKET	Tolerance :	Design	K.W Law	Remark	Scale
Item No.	AS-205-UL-EN(ST-A01-001L-5)	Unit : mm	Drawing	W.K Yeung	Remark	Material
			Check	K.L Wong	Remark	Drawing No. A701051630
			Approval	K.W Chan	Remark	Sheet