

PRODUCT NO.

10085901-****5E*LF

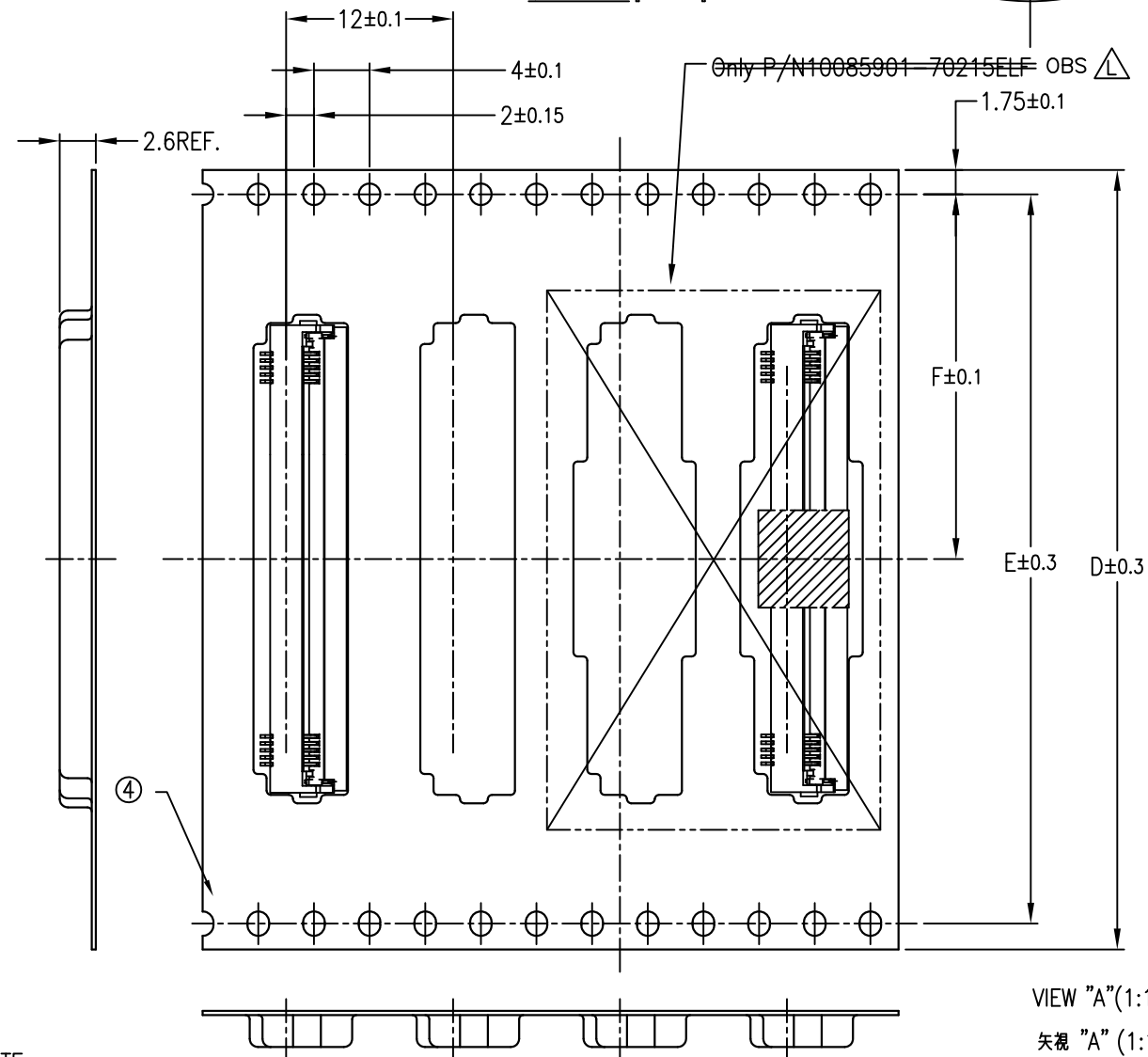
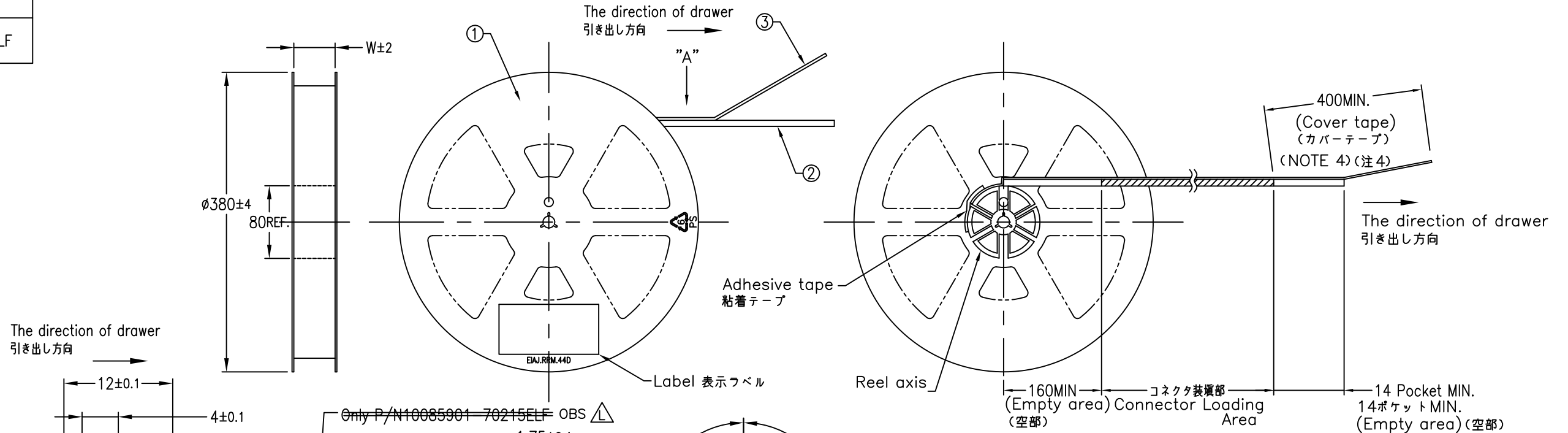

<P/N composition> <P/N 構成>

10085901-** * 1 5 E * LF

- Lead Free
- Blank: Standard material
- H: Halogen free material
- Packaging form (E : Plastic reel- Embossing tape package)
- Embossing tape package 5: 12mm PITCH
- Plating spec / Contact style 1: Au plating / Single contact point
- D: Au plating / Double contact point
- Blank: Without cable lock
- 1: With cable lock
- 2: Without cable lock / With picku-up tape
- No of position
- Series name

PARTS TABLE 部品表

No.	Part name 部品名	Material 材質	QTY.	Note 備考
①	The reel for packaging 梱包用リール	Polystyrene ポリスチレン	1	Color / Window of the reel: option 色 / リール窓: 任意 Electrification prevention processing 帯電防止処理品
②	Emboss tape エンボステープ	PS or A-PET	1	Electrification prevention processing 帯電防止処理品
③	Cover tape カバーテープ	Polyester, Polyethylene ポリエステル, ポリエチレン	1	
④	Connector コネクタ	See sheet 2	3000	

Part No. 型番	DIM "D" D寸法	DIM "E" E寸法	DIM "F" F寸法	DIM "W" W寸法
10085901-70*15E*LF	56	52.4	26.2	57.5
10085901-60*15E*LF				
10085901-50*15E*LF	44	40.4	20.2	45.5
10085901-35*15E*LF				

mat'l. code		surface ISO 1302 <input checked="" type="checkbox"/> ISO 406 ISO 1101		tolerance ISO 406 ISO 1101		projection 		product family 59KF FLEX 0.5	
ltr	ecn no	dr	date	tolerances unless otherwise specified		MM		title ASSEMBLY	
H	ELXJ-019682	Y.K	2014-12-09	angles	0.X/±0.3	MM		0.5mm PITCH CONNECTOR FOR FPC	
J	ELXJ-019892	Y.K	2015-01-06	linear	0.XX/±0.3	MM		VHC Series	
K	ELX-J-32995	Y.K	2019-03-25	0°±3'	0.XXX/±0.3	scale NA		dwg no	
L	ELX-J-44779	Y.K	2022-05-19	dr	Y.KAMEDA	2022-05-19		sheet 1 of 8	
				enr	Y.KAMEDA	2022-05-19		size 5	
F	ELXJ-010325	Y.K	2012-2-20	chr	MOHAMMAD-NABEEL	2022-05-19		10085901	
G	ELXJ-016518	Y.K	2013-12-16	appd	M.KAJIURA	2022-05-19		A3	
sheet		revision		L	L	L	L	type	
index		sheet		1	2	3	4	CUSTOMER Drawing	

NOTE

- This article carries out the emboss tape package of the P/N10085901 series connector.
- The shape and dimension of this article are based on JIS C 0806.
(Taping of electronic parts (Surface mounted device))
- The color and window of a plastic reel are optional.

注記

- 本品は P/N10085901シリーズをエンボステープ梱包したものである。
- 本品の形状及び寸法規定は JIS C 0806 (電子部品のテーピング (表面実装部品)) に準拠する。
- 本品の色及びリール窓は任意とする。

Amphenol FCI

© 2016 AFCE

©

D

A

B

C

D

PRODUCT NO.

10085901-***1*LF

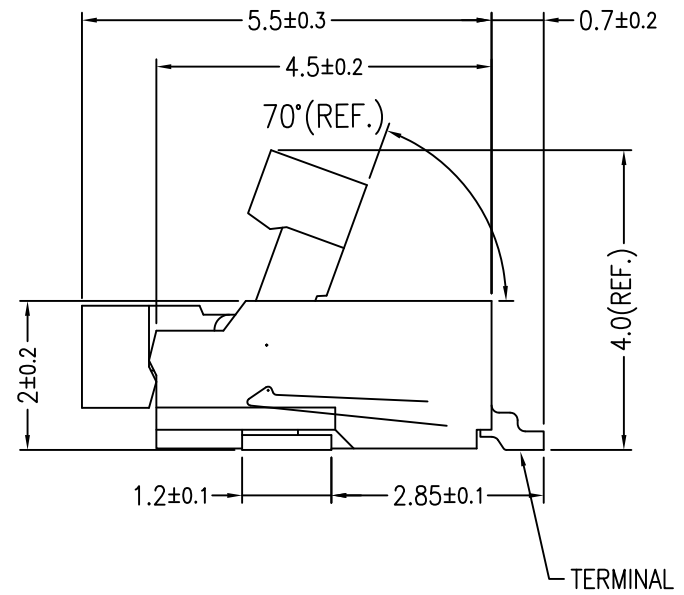
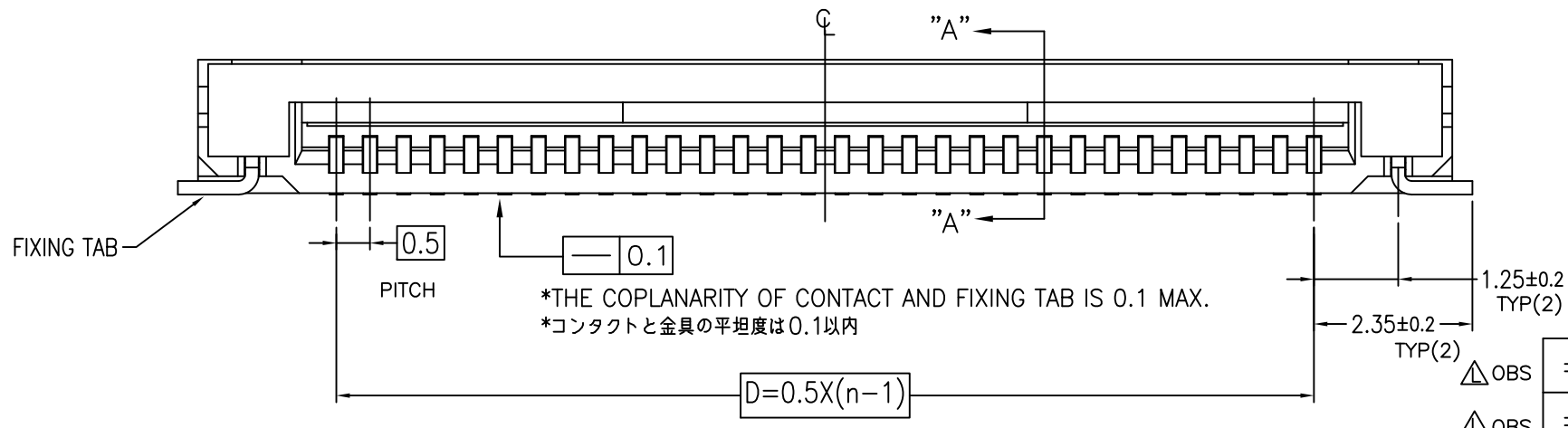
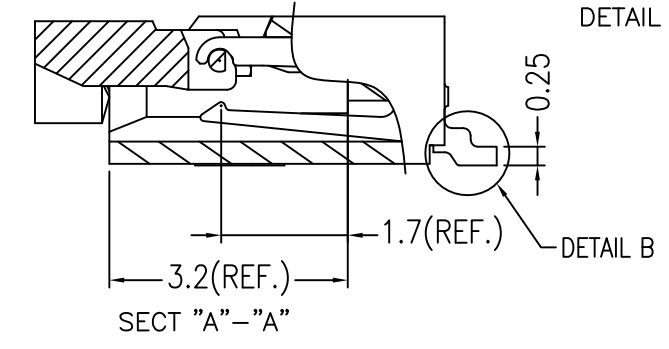
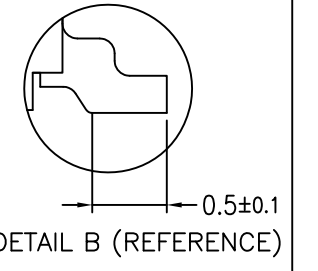
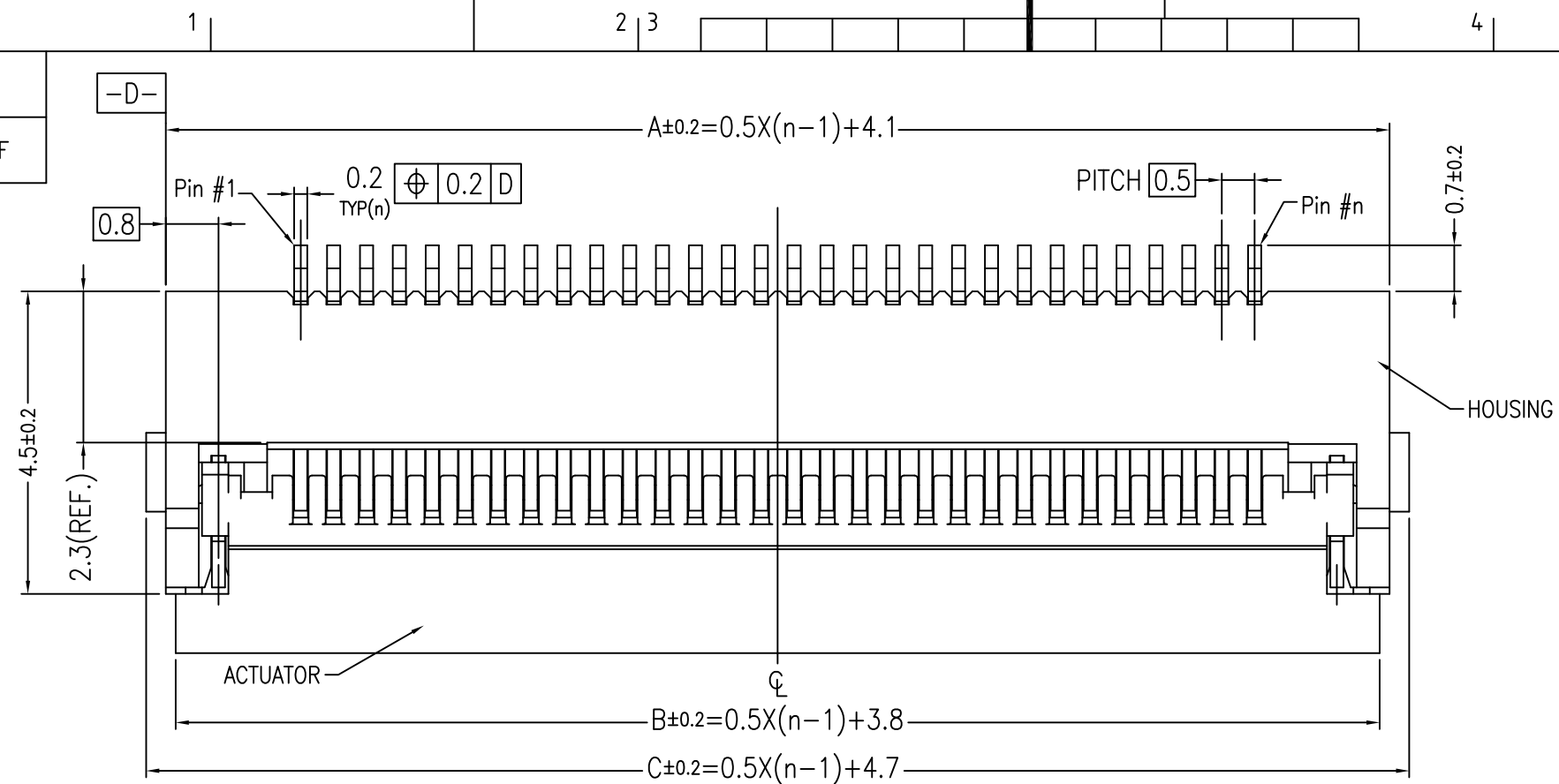

P/N	ACTUATOR COLOR	REMARK
-***1LF	NATURAL (BROWN)	STANDARD
-***1HLF	BLACK	HALOGEN FREE (less than 900ppm)

P/N	A	B	C	D	E
10085901-701HLF	38.6	38.3	39.2	34.5	40.3
10085901-701LF	38.6	38.3	39.2	34.5	40.3
10085901-601HLF	33.6	33.3	34.2	29.5	35.3
10085901-601LF	33.6	33.3	34.2	29.5	35.3
10085901-501HLF	28.6	28.3	29.2	24.5	30.3

NOTE
1.MATERIAL
1)HOUSING:THERMOPLASTIC RESIN,UL94V-0, NATURAL
2)ACTUATOR:THERMOPLASTIC RESIN,UL94V-0, BROWN
3)CONTACT:COPPER ALLOY (t=0.20)
4)FIXING TAB: COPPER ALLOY (t=0.20)
2.FINISH
1)CONTACT: ALL OVER Ni,Au FLASH.
2)FIXING TAB: ALL OVER Ni, Sn PLATING 1.5~3.5μm
3.CO-PLANARITY: 0.1 MAX.
5.RoHS
THIS PRODUCT MEETS EUROPEAN UNION DIRECTIVES AND OTHER COUNTRY REGULATIONSAS DESCRIBED IN GS-47-0004.

注記
1.材料
1)ハウジング:耐熱性樹脂,UL94V-0, ナチュラル
2)アクチュエータ:耐熱性樹脂,UL94V-0, ナチュラル (茶色)
3)端子:銅合金 (t=0.20)
4)固定金具:銅合金 (t=0.20)
2.めっき
1)端子: Ni下地付き, Auフラッシュ
2)固定金具: Ni下地付き, 錫めっき 1.5~3.5μm
3.コプラナリティ: 0.1 MAX.
5.RoHS
本製品は、GS-47-0004に記載されたヨーロッパ連合指令と他国の規制に適合しています。

mat'l. code				surface ISO 1302 ✓ ISO 406 ISO 1101		tolerance ISO 406 ISO 1101		projection MM		product family 59KF FLEX 0.5	
ltr	ecn	no	dr	date		tolerances unless otherwise specified		MM		title ASSEMBLY	
L						0.X/±0.2		scale 10:1		0.5mm PITCH CONNECTOR FOR FPC VHC Series	
						0.XX/±0.2				dwg no 10085901	
						0.XXX/±0.2				sheet 2 of 8	
						dr Y.KAMEDA 2022-05-19		Amphenol FCI		size 5	
						enrg Y.KAMEDA 2022-05-19				A3	
						chr MOHAMMAD-NABEEL 2022-05-19				type CUSTOMER Drawing	
						appd M.KAJIURA 2022-05-19					
sheet index	revision sheet										

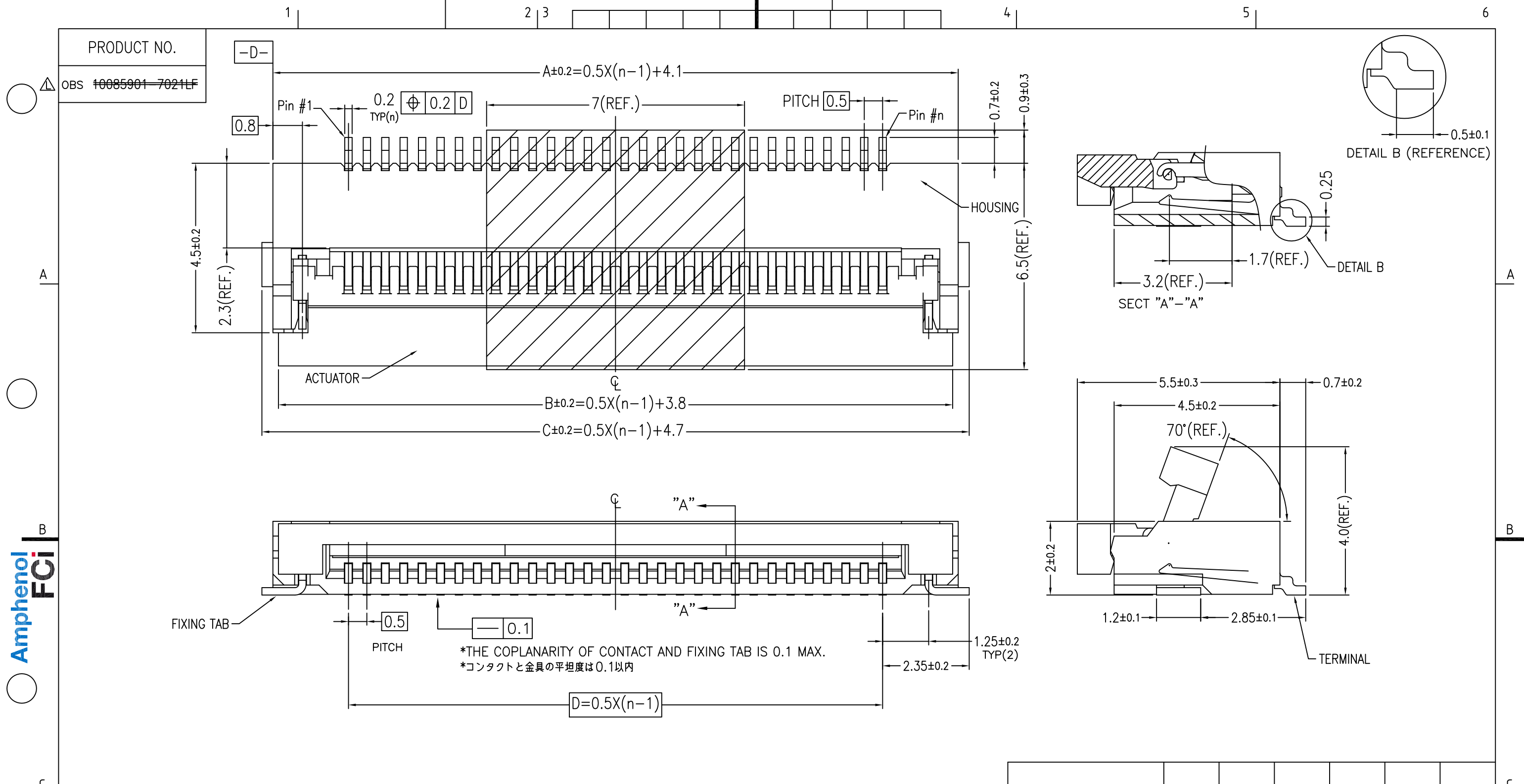

Amphenol FCI

© 2016 AFCE

NOTE

1.MATERIAL

1)HOUSING:THERMOPLASTIC RESIN,UL94V-0, NATURAL

2)ACTUATOR:THERMOPLASTIC RESIN,UL94V-0, BROWN

3)CONTACT:COPPER ALLOY (t=0.20)

4)FIXING TAB: COPPER ALLOY (t=0.20)

5)COVER TAPE: POLYIMIDE TAPE (t=0.075)

2.FINISH

1)CONTACT: ALL OVER Ni,Au FLASH.

2)FIXING TAB: ALL OVER Ni , Sn PLATING 1.5~3.5μm

3.CO-PLANARITY: 0.1 MAX.

5.RoHS

THIS PRODUCT MEETS EUROPEAN UNION DIRECTIVES AND OTHER COUNTRY REGULATIONSAS DESCRIBED IN GS-22-008.

注記

1.材料

1)ハウジング:耐熱性樹脂,UL94V-0, ナチュラル

2)アクチュエータ:耐熱性樹脂,UL94V-0, ナチュラル (茶色)

3)端子: 銅合金 (t=0.20)

4)固定金具: 銅合金 (t=0.20)

5)吸着テープ: ポリイミドテープ (t=0.075)

2.めっき

1)端子: Ni下地付き, Auフラッシュ

2)固定金具: Ni下地付き, 錫めっき 1.5~3.5μm

3.コプラナリティ: 0.1 MAX.

5.RoHS

本製品は、GS-22-008に記載されたヨーロッパ連合指令と他国の規制に適合しています。

△ OBS		10085901-7021LF	38.6	38.3	39.2	34.5	40.3
		P/N	A	B	C	D	E
mat'l. code		surface ISO 1302 ✓ ISO 406 ISO 1101	tolerance ISO 406 ISO 1101		projection MM		product family 59KF FLEX 0.5
ltr	ecn no	dr	date	tolerances unless otherwise specified		title ASSEMBLY	
L				angles 0°±2'	linear 0.X/±0.2 0.XX/±0.2 0.XXX/±0.2	0.5mm PITCH CONNECTOR FOR FPC VHC Series	
		dr	Y.KAMEDA	2022-05-19	scale 10:1		dwg no
		enrg	Y.KAMEDA	2022-05-19	Amphenol FCI		sheet 3 of 8
		chr	MOHAMMAD-NABEEL	2022-05-19			size 5
		appd	M.KAJIURA	2022-05-19			A3
sheet index		revision sheet		type		CUSTOMER Drawing	

PRODUCT NO.

10085901-***1*LF

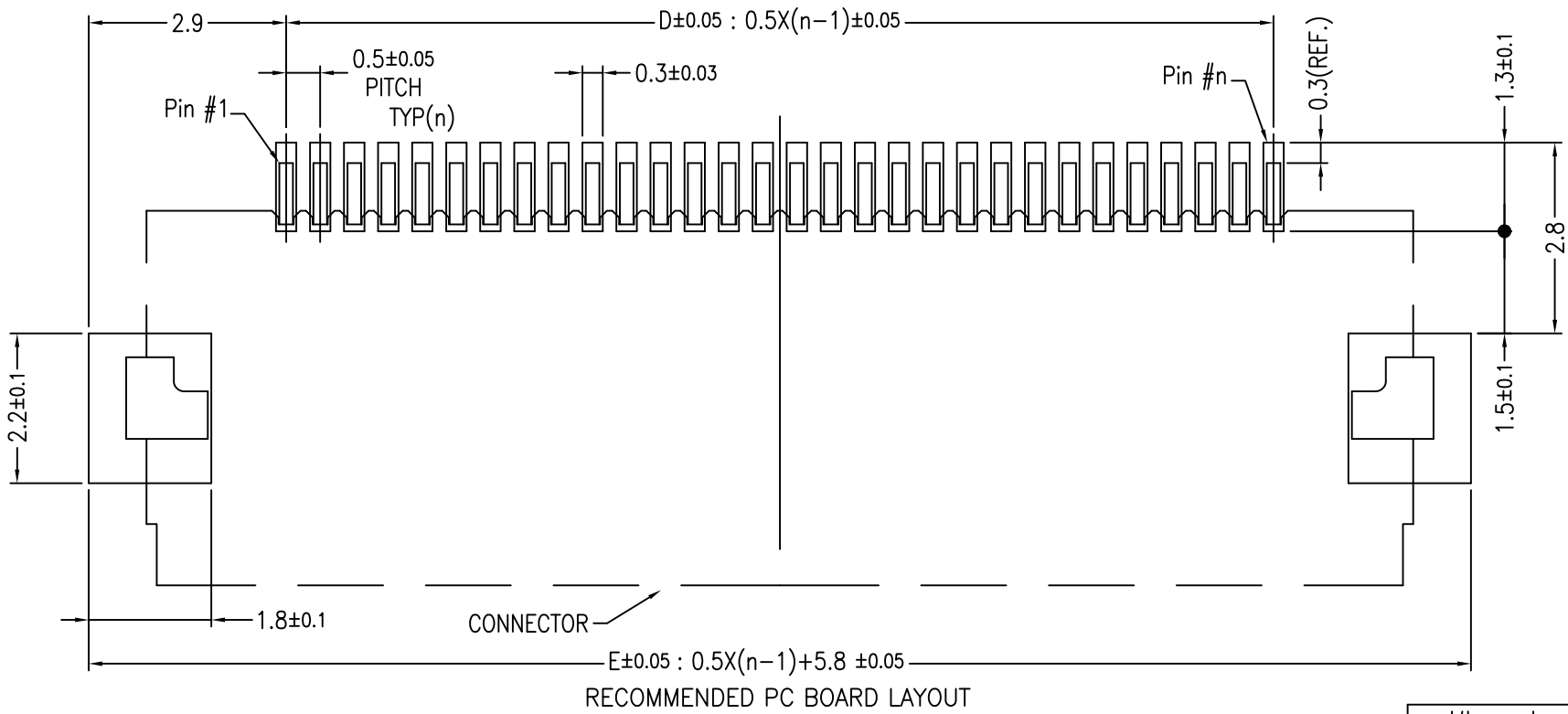
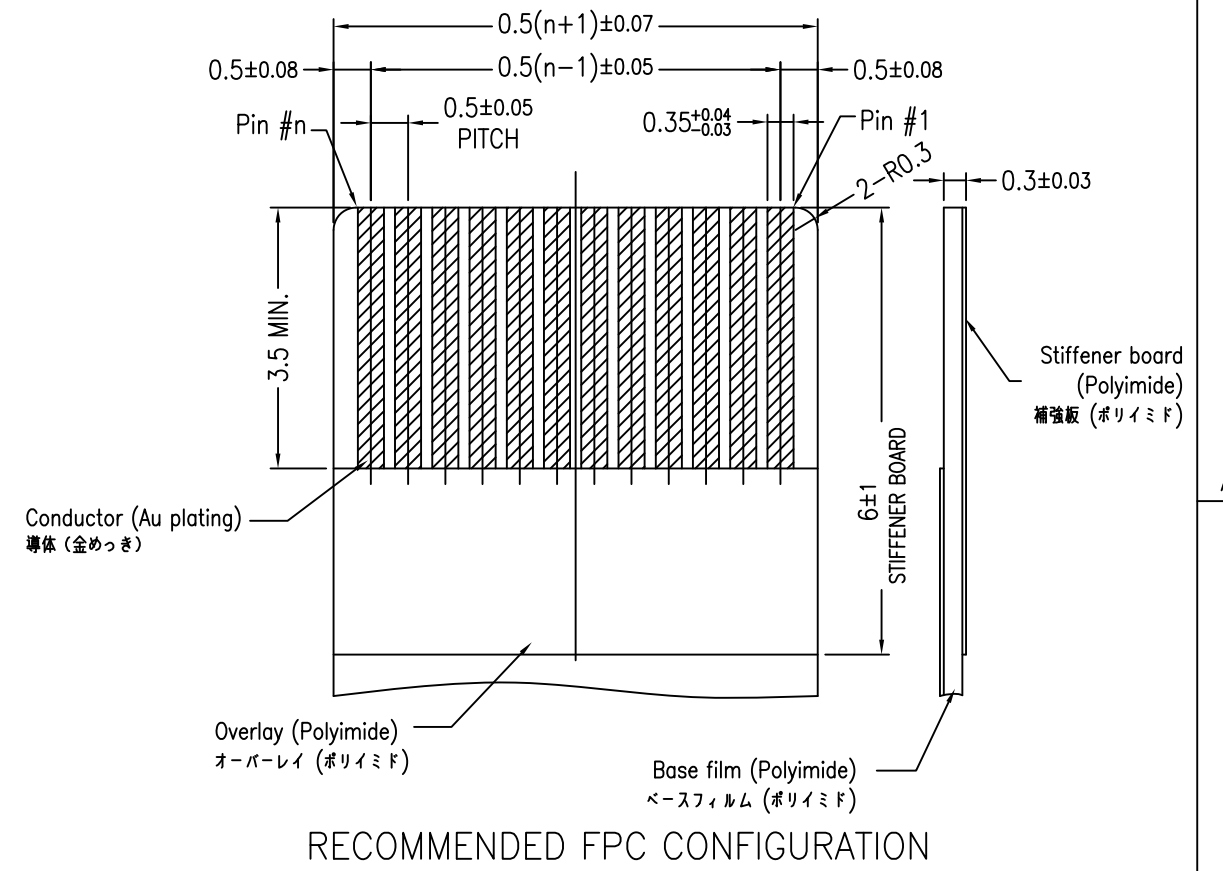
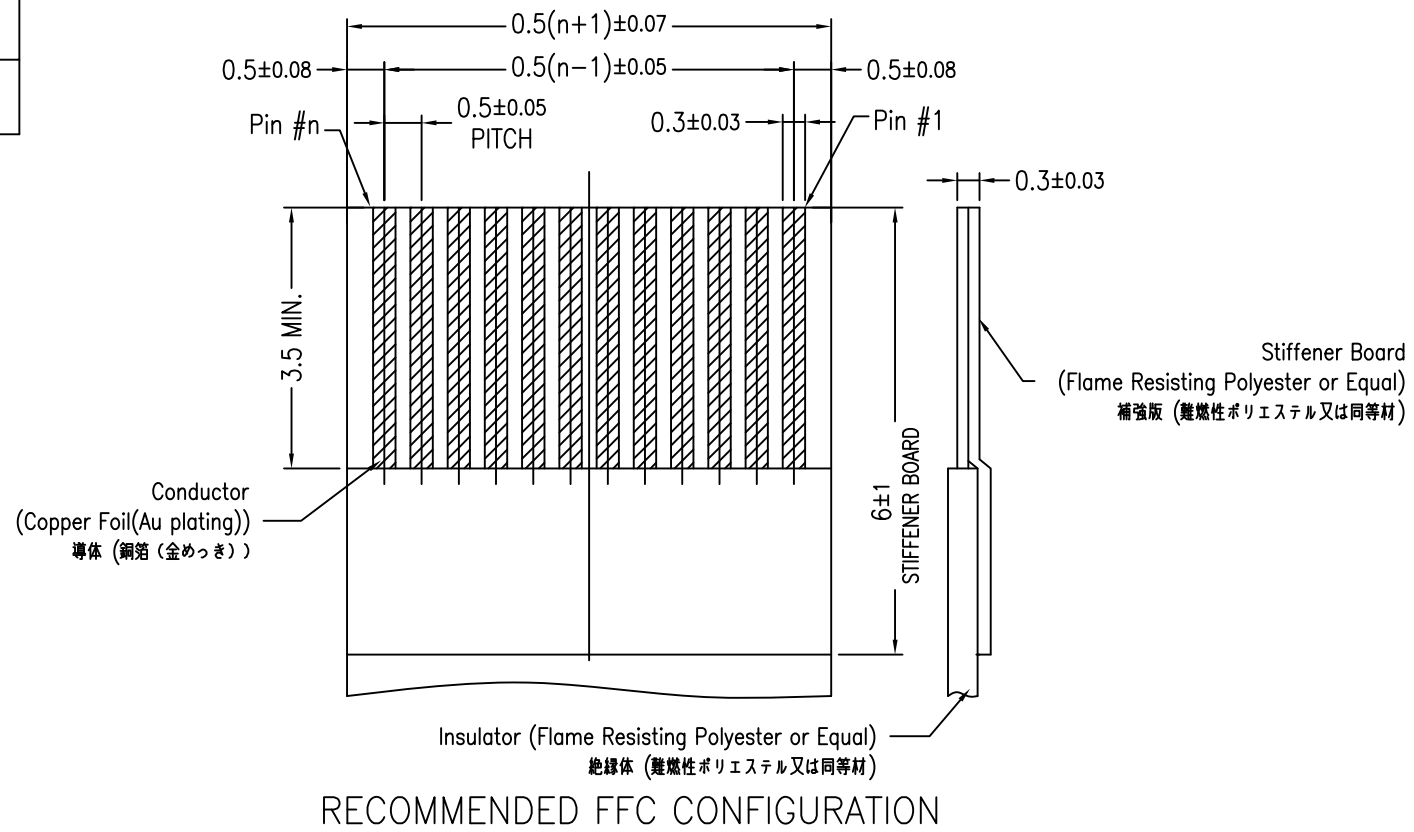

△ OBS	10085901-701HLF	38.6	38.3	39.2	34.5	40.3
△ OBS	10085901-701LF	38.6	38.3	39.2	34.5	40.3
△ OBS	10085901-7021LF	38.6	38.3	39.2	34.5	40.3
	10085901-601HLF	33.6	33.3	34.2	29.5	35.3
	10085901-601LF	33.6	33.3	34.2	29.5	35.3
	10085901-501HLF	28.6	28.3	29.2	24.5	30.3
	P/N	A	B	C	D	E

NOTE
 1.THICKNESS OF A METAL MASK: 0.1mm
 2.FPC / FFC
 ADHESIVE METHOD OF SUPPORTING TAPE SHALL BE HEAT CRIMPING METHOD AND THERMOSETTING ADHESIVE MATERIAL SHALL BE USED.
 3.OTHER SPECIFICATIONS
 PRODUCT SPECIFICATION : GS-12-541
 APPLICATION SPECIFICATION : GS-20-105
 PACKAGING SPECIFICATION : GS-14-1264

注記
 1.メタルマスク厚 : 0.1mm
 2.FPC / FFC
 FPCの補強板接着剤には熱硬化接着剤を使用し、接着方式は熱圧着とする。
 3.その他
 製品規格 : GS-12-541
 取り扱い説明書 : GS-20-105
 梱包規格 : GS-14-1264

mat'l. code		surface	tolerance	projection	product family
ltr		ISO 1302	ISO 406 ISO 1101		59KF FLEX 0.5
ecn no		tolerances unless otherwise specified			title
dr		angles	0.X/±0.2		ASSEMBLY
date		linear	0.XX/±0.2		0.5mm PITCH CONNECTOR FOR FPC VHC Series
L		0°±2'	0.XXX/±0.2	scale 10:1	dwg no
		dr	Y.KAMEDA 2022-05-19		sheet 4 of 8
		enr	Y.KAMEDA 2022-05-19		size
		chr	MOHAMMAD-NABEEL 2022-05-19		10085901
		appd	M.KAJIURA 2022-05-19		A3
sheet index		revision sheet			type
					CUSTOMER Drawing

PRODUCT NO.

10085901-**11*LF

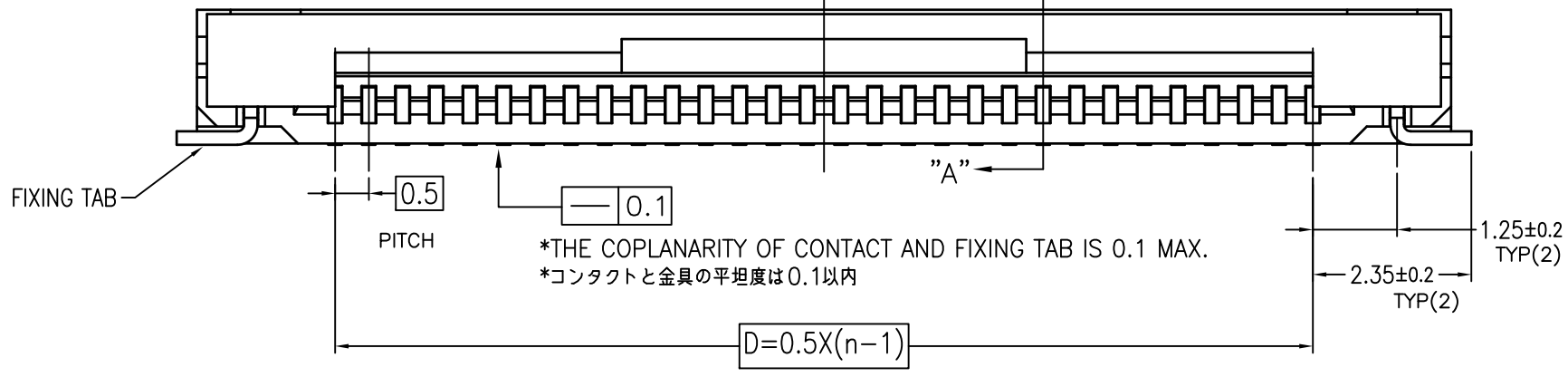
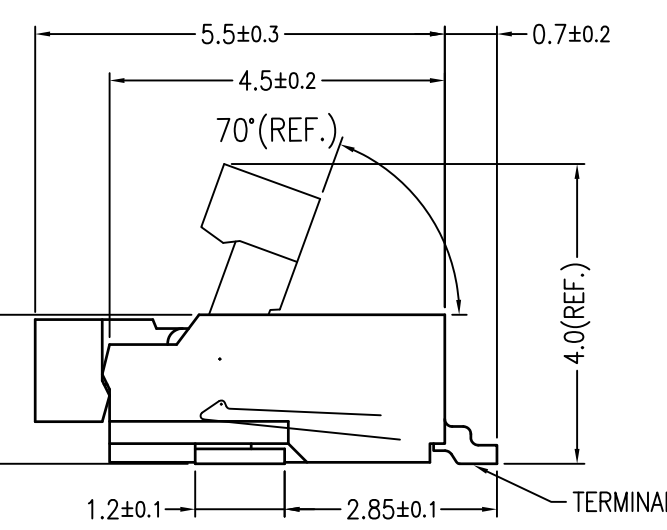
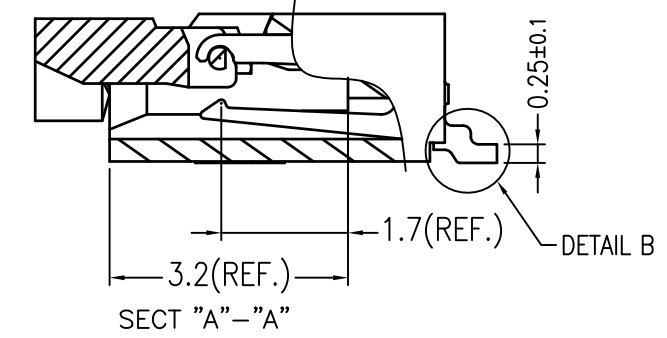
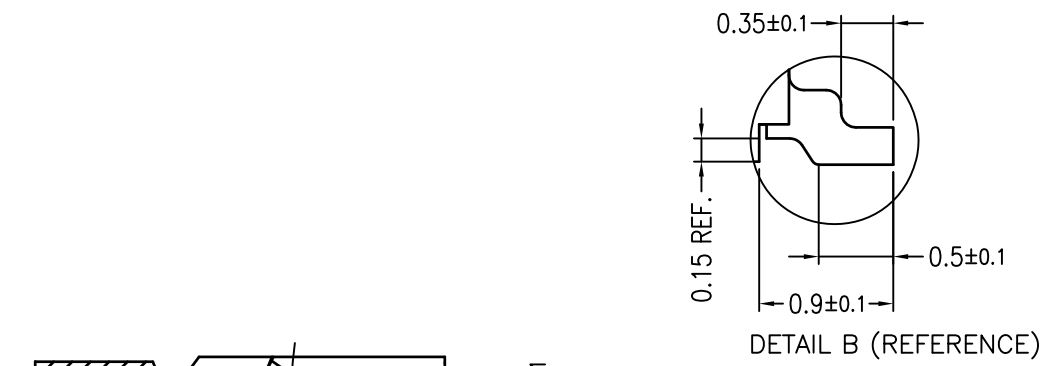
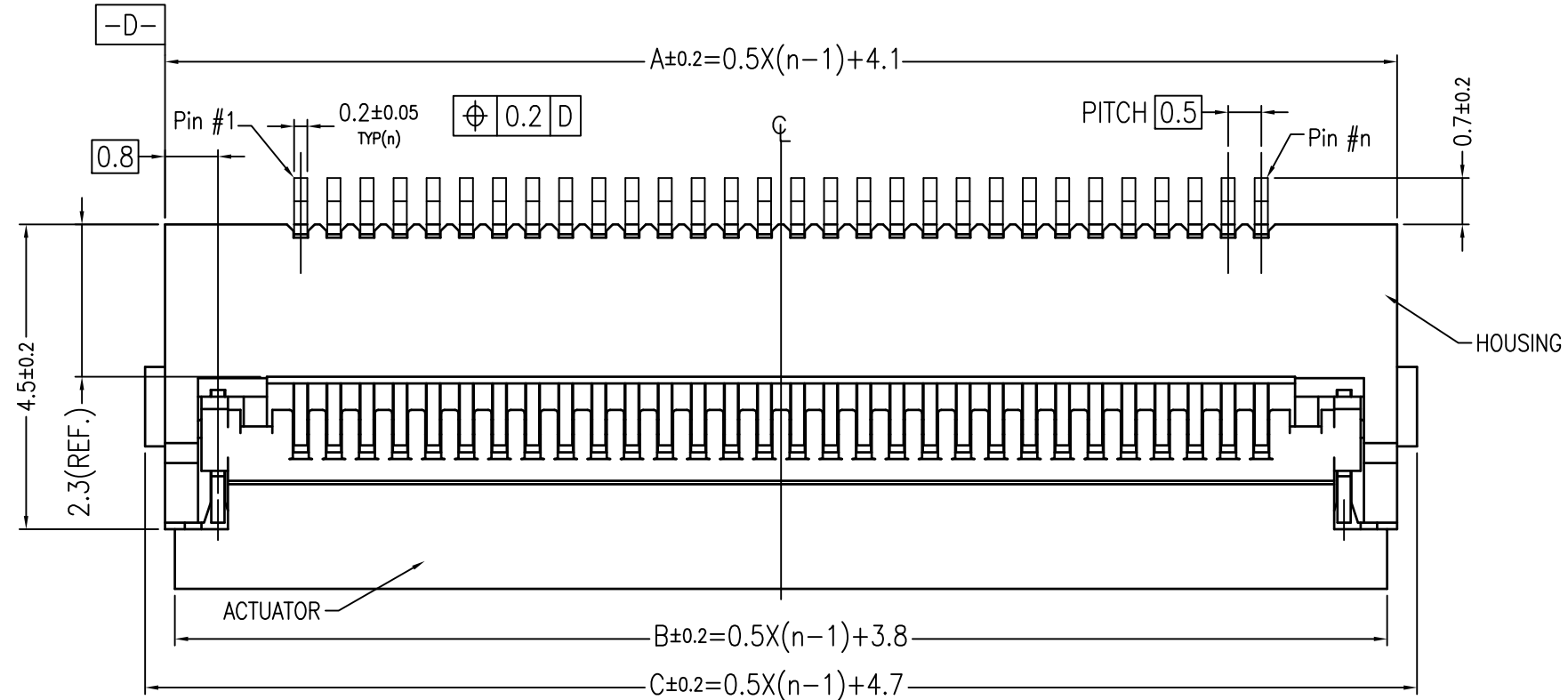

△ OBS	P/N	A	B	C	D	E
	10085901-7011LF	38.6	38.3	39.2	34.5	40.3
	10085901-6011LF	33.6	33.3	34.2	29.5	35.3
	10085901-6011HLF	33.6	33.3	34.2	29.5	35.3
	10085901-5011LF	28.6	28.3	29.2	24.5	30.3
	10085901-5011HLF	28.6	28.3	29.2	24.5	30.3
	10085901-3511LF	21.1	20.8	21.7	17.0	22.8
	P/N	A	B	C	D	E

P/N	ACTUATOR COLOR	REMARK
-**11LF	NATURAL (BROWN)	STANDARD
-**11HLF	BLACK	HALOGEN FREE (less than 900ppm)

NOTE
 1.MATERIAL
 1)HOUSING:THERMOPLASTIC RESIN,UL94V-0, NATURAL
 2)ACTUATOR:THERMOPLASTIC RESIN,UL94V-0, BROWN
 3)CONTACT:COPPER ALLOY (t=0.20)
 4)FIXING TAB: COPPER ALLOY (t=0.20)
 2.FINISH
 1)CONTACT: ALL OVER Ni,Au FLASH.
 2)FIXING TAB: ALL OVER Ni, Sn PLATING 1.5~3.5μm
 3.CO-PLANARITY: 0.1 MAX.
 5.RoHS
 THIS PRODUCT MEETS EUROPEAN UNION DIRECTIVES AND OTHER COUNTRY REGULATIONSAS DESCRIBED IN GS-22-008

mat'l. code	surface ISO 1302	tolerance ISO 406 ISO 1101	projection	product family
ltr	ecn no	dr	date	59KF FLEX 0.5
L				title
				ASSEMBLY
				0.5mm PITCH CONNECTOR FOR FPC VHC Series
				scale 10:1
				dwg no
				sheet 5 of 8
				size
				5
				10085901
				A3
				type
				CUSTOMER Drawing

PRODUCT NO.

10085901-**11*LF

Cut through both sides conductors.

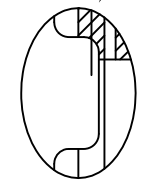

DETAIL "A"

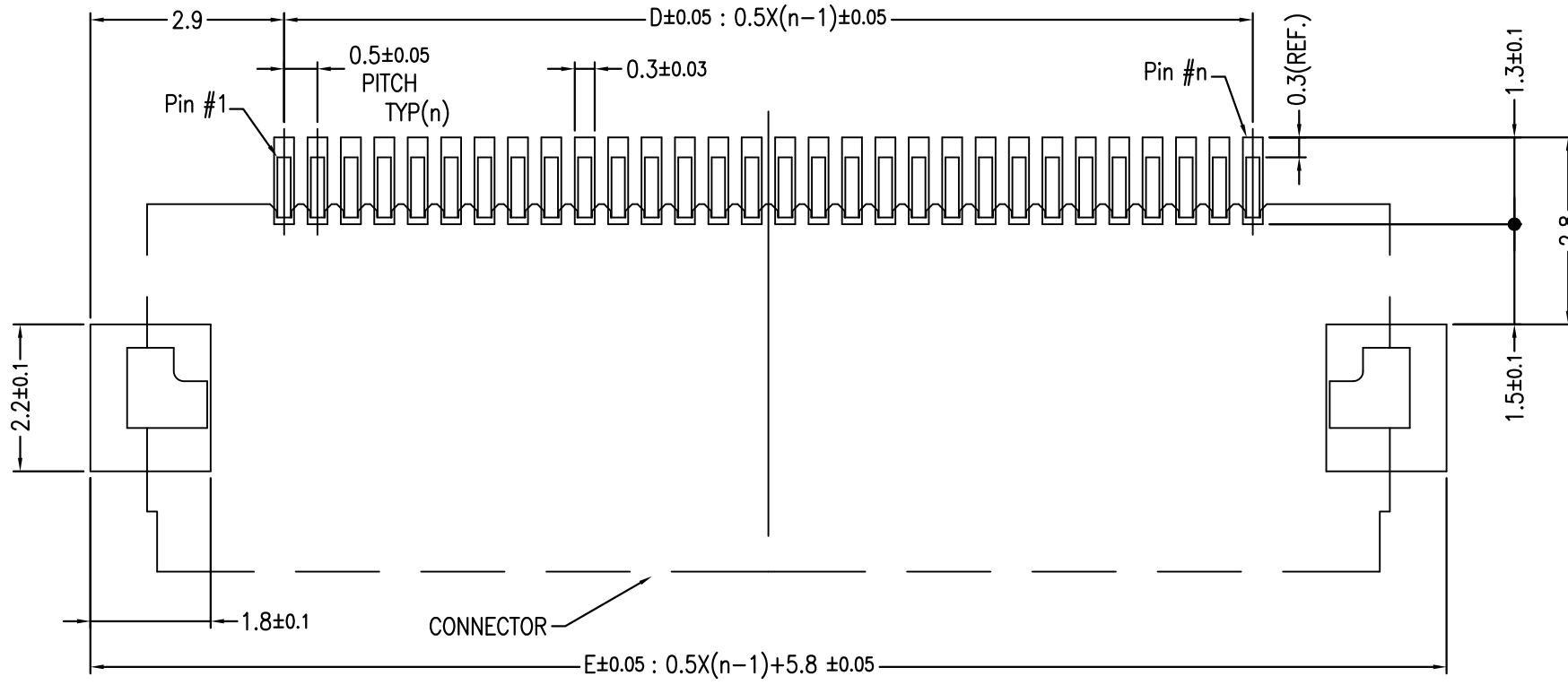
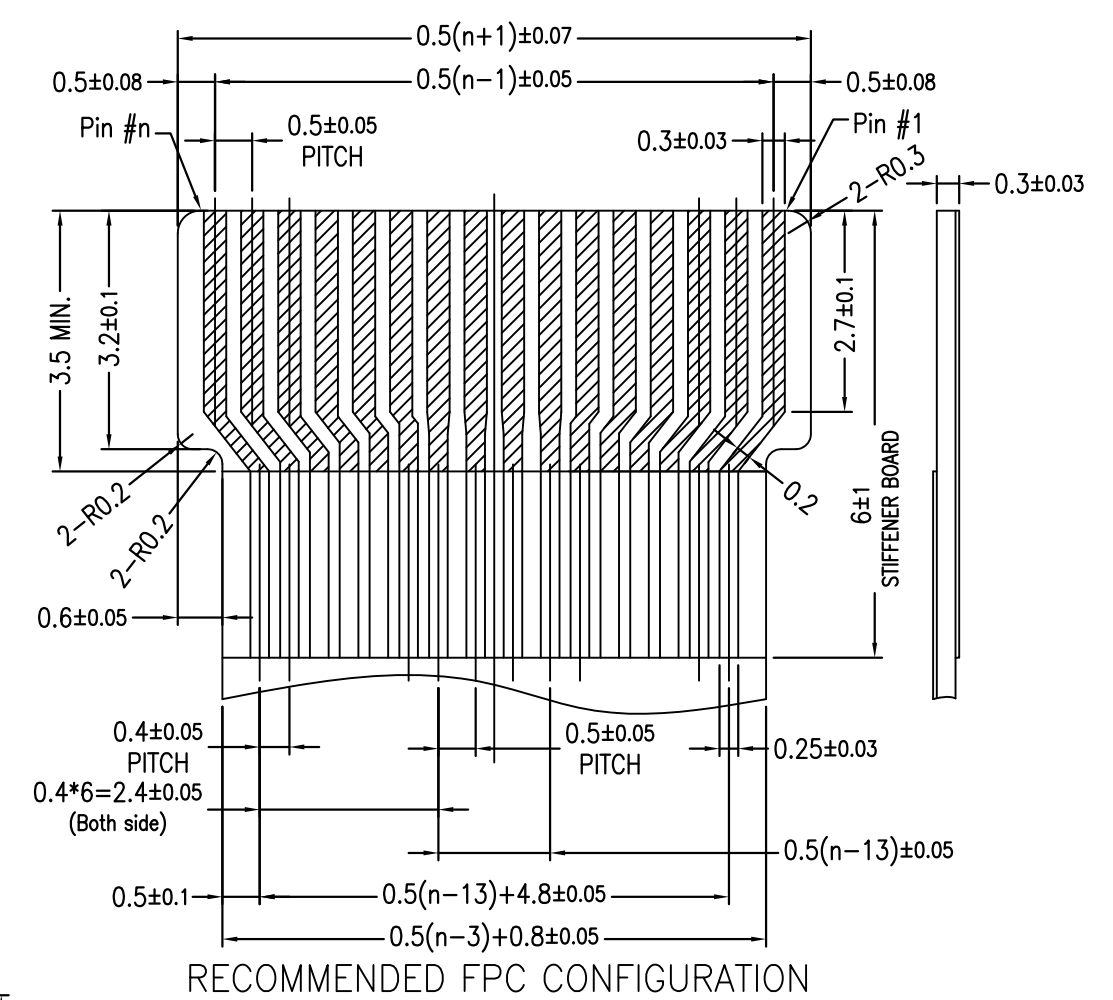
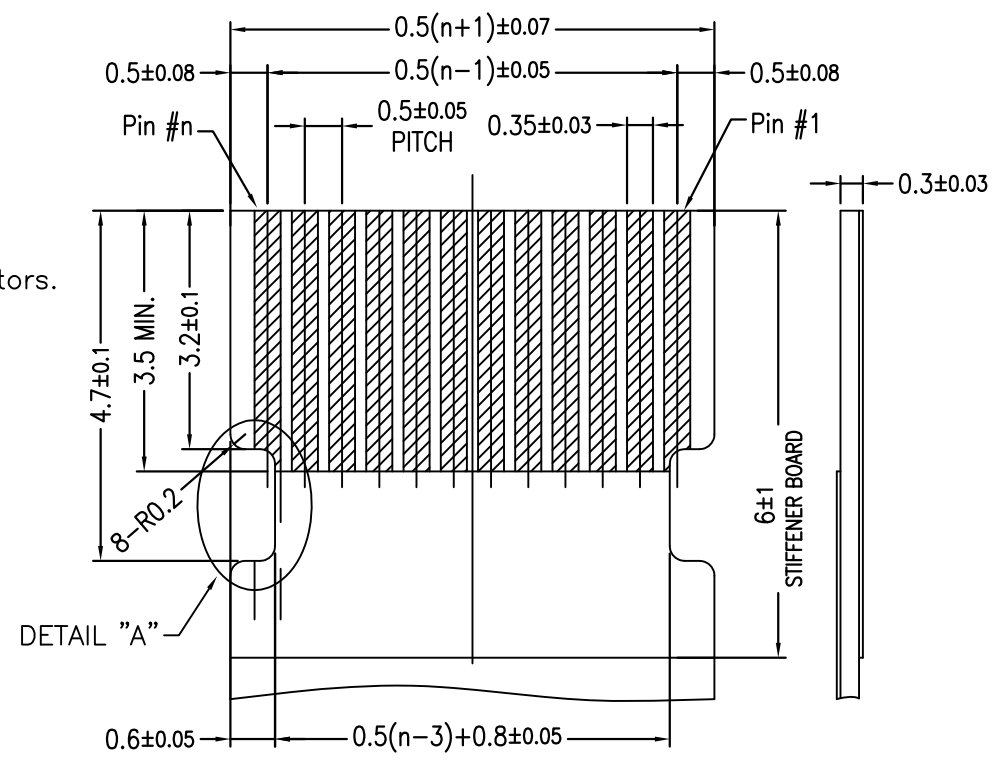

P/N	A	B	C	D	E
10085901-7011LF	38.6	38.3	39.2	34.5	40.3
10085901-6011LF	33.6	33.3	34.2	29.5	35.3
10085901-6011HLF	33.6	33.3	34.2	29.5	35.3
10085901-5011LF	28.6	28.3	29.2	24.5	30.3
10085901-5011HLF	28.6	28.3	29.2	24.5	30.3
10085901-3511LF	21.1	20.8	21.7	17.0	22.8

NOTE

- THICKNESS OF A METAL MASK: 0.1mm
- FPC / FFC
ADHESIVE METHOD OF SUPPORTING TAPE SHALL BE HEAT CRIMPING METHOD AND THERMOSETTING ADHESIVE MATERIAL SHALL BE USED.
- ACCORDING TO THE KIND OF CABLE TO BE USED, SINCE OUTSIDE TWO CONDUCTORS CANNOT BE USED, THE LINE OF SIGNAL DECREASES.

注記

- メタルマスク厚 : 0.1mm
- FPC / FFC
FPCの補強板接着剤には熱硬化接着剤を使用し、接着方式は熱圧着とする。
- 使用するケーブルの種類によっては、外側の2つの導体が使用不可能になるため信号ラインが減少します。

mat'l. code	surface ISO 1302	tolerance ISO 406 ISO 1101	projection MM	product family 59KF FLEX 0.5
ltr	ecn no	dr	date	title ASSEMBLY
L				0.5mm PITCH CONNECTOR FOR FPC VHC Series
	angles	linear	scale 10:1	dwg no 10085901
	$0^\circ \pm 2'$	$0.X/\pm 0.2$ $0.XX/\pm 0.2$ $0.XXX/\pm 0.2$		sheet 6 of 8 size 5 A3
	dr	Y.KAMEDA	2022-05-19	type CUSTOMER Drawing
	enrg	Y.KAMEDA	2022-05-19	
	chr	MOHAMMAD-NABEEL	2022-05-19	
	appd	M.KAJIURA	2022-05-19	
sheet index	revision sheet			

PRODUCT NO.

10085901-**-DHLF

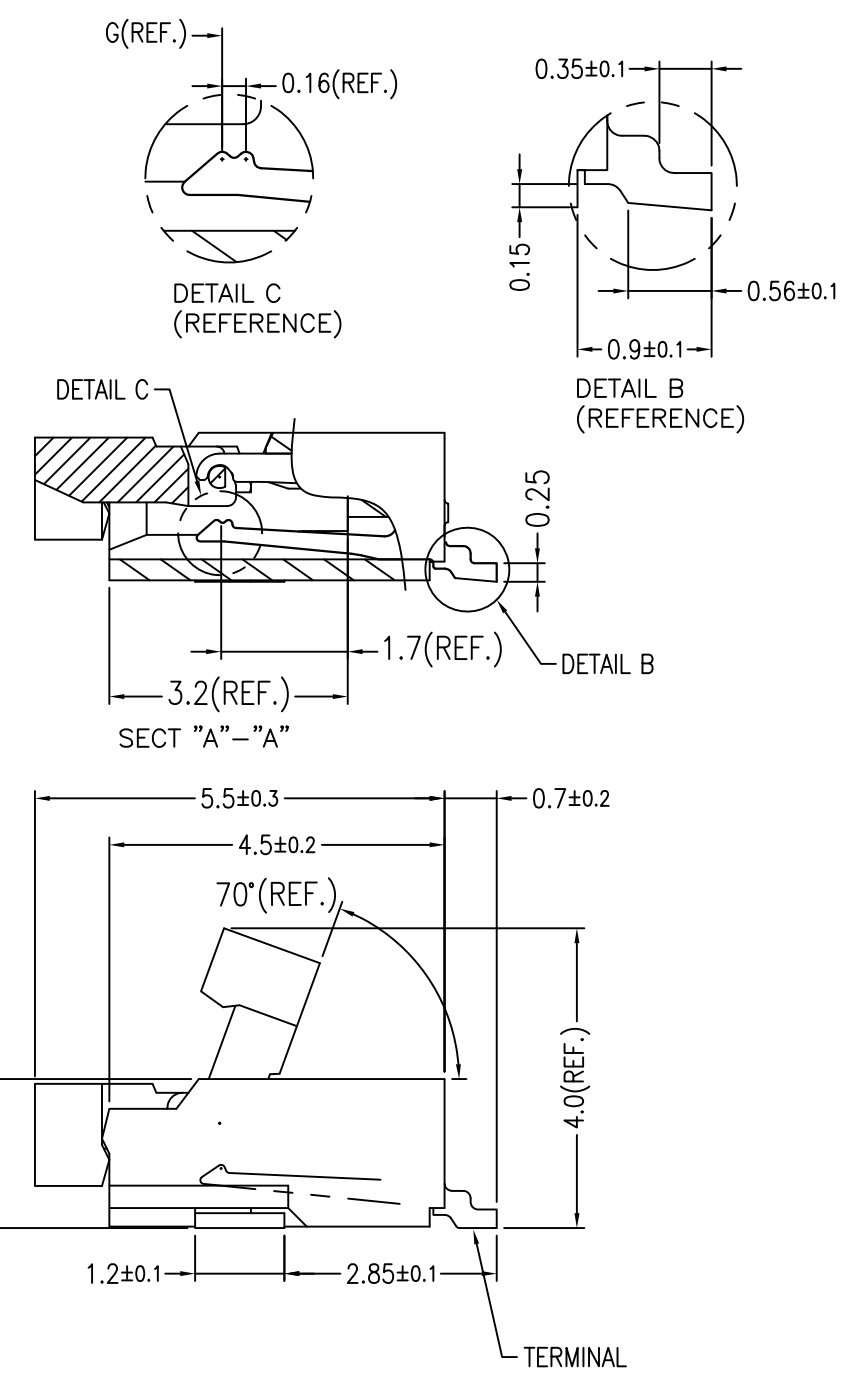
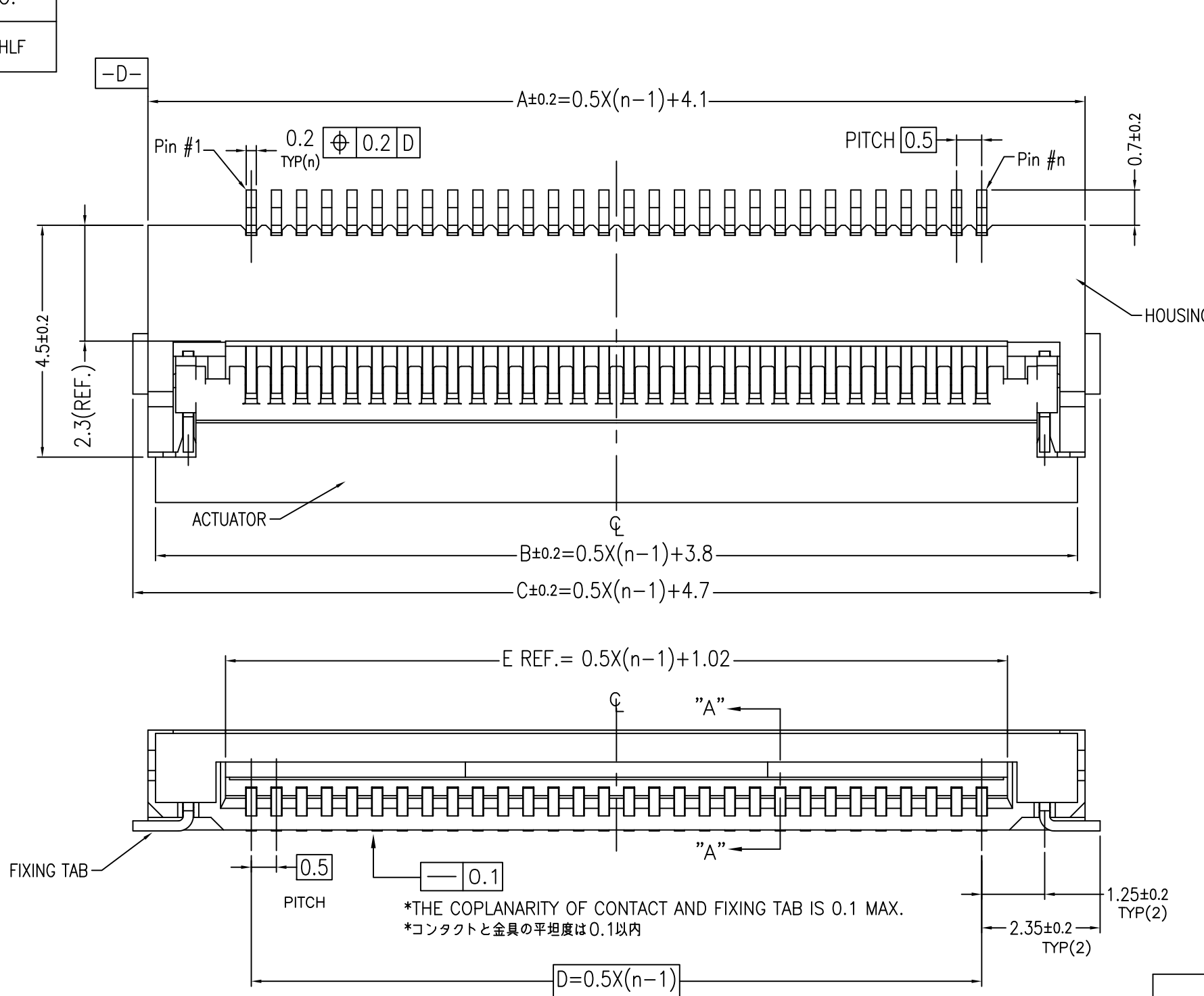

FIXING TAB

PITCH 0.5

0.1

*THE COPLANARITY OF CONTACT AND FIXING TAB IS 0.1 MAX.
*コンタクトと金具の平坦度は0.1以内

1.25±0.2 TYP(2)

2.35±0.2 TYP(2)

D=0.5X(n-1)

NOTE

1.MATERIAL
 1)HOUSING:THERMOPLASTIC RESIN,UL94V-0, NATURAL
 2)ACTUATOR:THERMOPLASTIC RESIN,UL94V-0, BLACK
 3)CONTACT:COPPER ALLOY (t=0.20)
 4)FIXING TAB: COPPER ALLOY (t=0.20)

2.FINISH
 1)CONTACT: ALL OVER Ni,Au FLASH.
 2)FIXING TAB: ALL OVER Ni , Sn PLATING 1.5~3.5μm
 3.CO-PLANARITY: 0.1 MAX.
 4.RoHS
 THIS PRODUCT MEETS EUROPEAN UNION DIRECTIVES AND OTHER COUNTRY REGULATIONSAS DESCRIBED IN GS-22-008.

5.HALOGEN FREE
 Cl: Less than 900ppm
 Br: Less than 900ppm
 Cl + Br: Less than 1500ppm

注記

1.材料
 1)ハウジング:耐熱性樹脂,UL94V-0, ナチュラル
 2)アクチュエータ:耐熱性樹脂,UL94V-0, 黒色
 3)端子: 銅合金 (t=0.20)
 4)固定金具: 銅合金 (t=0.20)

2.めっき
 1)端子: Ni下地付き, Auフラッシュ
 2)固定金具: Ni下地付き, 錫めっき 1.5~3.5μm
 3.コプラナリティ: 0.1 MAX.
 4.RoHS
 本製品は、GS-22-008に記載されたヨーロッパ連合指令と他国の規制に適合しています。
 5.ハロゲンフリー
 本製品は、塩素含有量900ppm以下、臭素含有量900ppm以下、塩素+臭素含有量の総量1500ppm以下を含んでおります。

10085901-50DHLF	28.6	28.3	29.2	24.5	25.52	30.3
P/N	A	B	C	D	E	F

mat'l. code	surface ISO 1302 ✓ ISO 406 ISO 1101	tolerance ISO 406 ISO 1101	projection MM	product family 59KF FLEX 0.5
ltr	ecn no	dr	date	title ASSEMBLY
L				0.5mm PITCH CONNECTOR FOR FPC VHC Series
				scale 10:1
				dwg no 10085901
				sheet 7 of 8
				size A3
				type CUSTOMER Drawing
sheet index	revision sheet			

