

# FUJITSU Component Wireless Modules

## Bluetooth® Version 4.1 Sensor Embedded Beacon

### FWM8BLZ02A-109047

#### Overview

A Bluetooth Version 4.1 sensor embedded beacon with accelerometer and temperature sensors



#### Features

- **Selection of 3 types of sensor data reporting**
  - Via Fujitsu Components Data Communication (FDC)\*  
Beacon outputs sensor data in preset intervals
  - Using Sensor Value Characteristic\*\*  
Data is stored in sensor module and central equipment accesses the module to read data
- **OTA configuration mode**  
In *Over-The-Air* (OTA) config mode the beacon unit settings and data can be re-configured by connecting to the central device wirelessly
- **LED status**  
The Beacon status can be checked by the LED indicator
- **Long operation life with coin cell battery**  
The Beacon is able to operate for more than 2 years with a CR2450 coin cell battery at 1 second advertise interval

RoHS compliant



FWM8BLZ02A-109047

#### Applications

- State monitors (logistics, nursing services, etc.)
- Front-end device of IoT platforms

Notes: \*: Fujitsu Component unique data transmission profile, equipped in the beacon as standard

\*\* : Sensor Value Characteristic is a function set in 'Characteristic', GATT specification of Bluetooth Smart, to have central equipment read.

Sensor Value Characteristic is Fujitsu Component unique name

Item	Specifications	
Part number	FWM8BLZ02A-109047	
Antenna	Pattern antenna	
Bluetooth technology	Conforms to Bluetooth Version 4.1 technology	
Transmit power	-16, -12, -8, -4, 0, +4 dBm (changeable by command)	
Power supply	CR family coin type lithium battery CR2450 (not included)	
Operating temperature / humidity	-30°C to +60°C, 20 to 80% RH	
Sensor	Sense interval	Typical 990ms (range 99 to 60,000ms)
	Acceleration sensor	Range of detection: ±16G, accuracy: ±3%
	Temperature sensor	Range of detection: -30°C to +60°C, accuracy : ±0.3°C
Dimensions / Weight	40 x 31 x 12mm / Approx. 10g (without battery)	
Certifications	Bluetooth qualification (QDID), Radio Act (Japan), FCC, IC, CE	

■ Battery specifications

Note: Use of coin type lithium battery CR2450  
 Please use the battery meets Figure 1 (minus electrode height min. 0.9mm, diameter max. 23 mm) to keep enough clearance between beacon holder and battery.

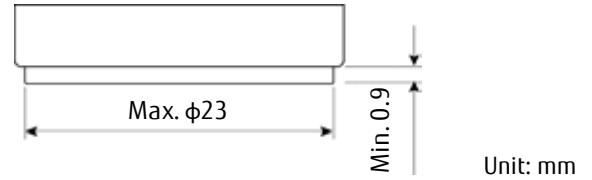
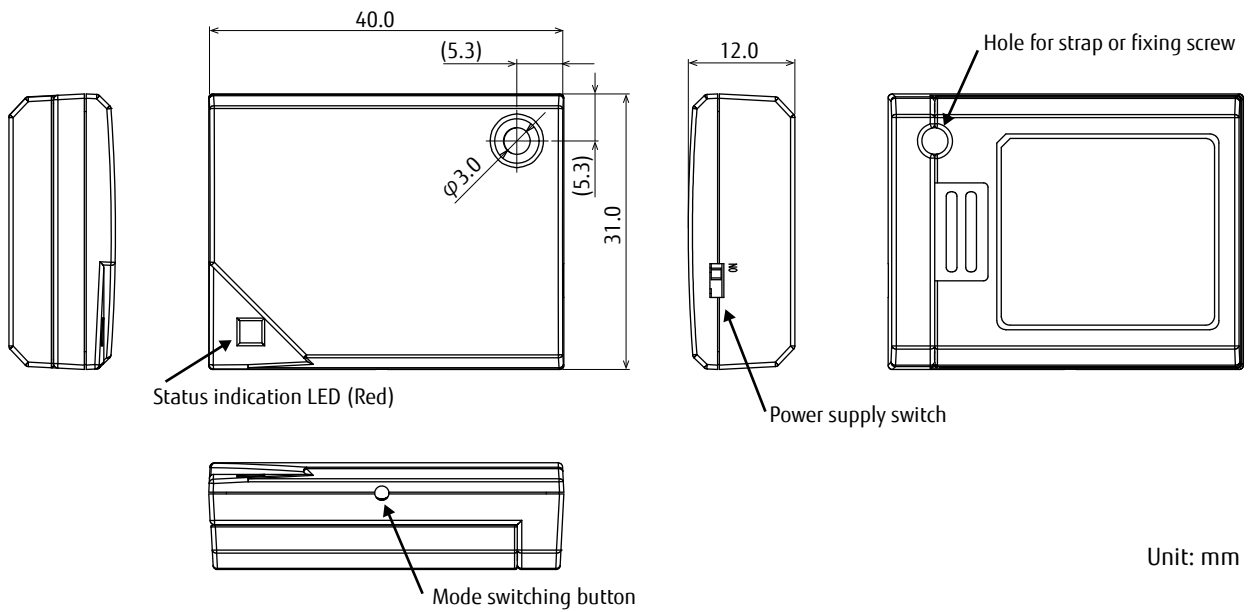

Figure 1

Unit: mm

■ Dimensions

FWM8BLZ02A-109047



Unit: mm

Note: The *Bluetooth*® word mark and logos are registered trademarks owned by Bluetooth SIG, Inc. and any use of such marks by Fujitsu Component is under license. Other trademarks and trade names are those of their respective owners.

Contact

**Japan**  
 FUJITSU COMPONENT LIMITED  
 Shinagawa Seaside Park Tower  
 12-4, Higashi-shinagawa 4-chome,  
 Tokyo 140 0002, Japan  
 Tel: (81-3) 3450-1682  
 Fax: (81-3) 3474-2385  
 Email: fcl-contact@cs.jp.fujitsu.com  
 Web: www.fujitsu.com/jp/group/fcl/en/

**Europe**  
 FUJITSU COMPONENTS EUROPE B.V.  
 Diamantlaan 25  
 2132 WV Hoofddorp  
 Netherlands  
 Tel: (31-23) 5560910  
 Fax: (31-23) 5560950  
 Email: info@fceu.fujitsu.com  
 Web: emea.fujitsu.com/components/

**China**  
 FUJITSU ELECTRONIC COMPONENTS  
 (SHANGHAI) CO., LTD.  
 Unit 4306, InterContinental Center  
 100 Yu Tong Road, Shanghai 200070, China  
 Tel: (86 21) 3253 0998 /Fax: (86 21) 3253 0997  
 Email: fcal@sg.fujitsu.com  
 www.fujitsu.com/sg/products/devices/  
 components/

**Korea**  
 FUJITSU COMPONENTS KOREA, LTD.  
 Alpha Tower #403,  
 645 Sampyeong-dong,  
 Bundang-gu, Seongnam-si,  
 Gyeonggi-do, 13524 Korea  
 Tel: (82 31) 708-7108  
 Fax: (82 31) 709-7108  
 Email: fcal@sg.fujitsu.com  
 www.fujitsu.com/sg/products/  
 devices/components/

**North and South America**  
 FUJITSU COMPONENTS AMERICA, INC.  
 2290 North First Street, Suite 212  
 San Jose, CA 95131 U.S.A.  
 Tel: (1-408) 745-4900  
 Fax: (1-408) 745-4970  
 Email: components@us.fujitsu.com  
 Web: http://us.fujitsu.com/components/

**Asia Pacific**  
 FUJITSU COMPONENTS ASIA, Ltd.  
 102E Pasir Panjang Road  
 #01-01 Citilink Warehouse Complex,  
 Singapore 118529  
 Tel: (65) 6375-8560 / Fax: (65) 6273-3021  
 Email: fcal@sg.fujitsu.com  
 www.fujitsu.com/sg/products/devices/  
 components/

**Hong Kong**  
 FUJITSU COMPONENTS HONG KONG Co., Ltd.  
 Room 06, 28/F, Greenfield Tower, Concordia  
 Plaza, No.1 Science Museum Road,  
 Tsim Sha Tsui East, Kowloon, Hong Kong  
 Tel: (852) 2881 8495 Fax: (852) 2894 9512  
 Email: fcal@sg.fujitsu.com  
 www.fujitsu.com/sg/products/devices/  
 components/

Copyright

All trademarks or registered trademarks are the property of their respective owners. Fujitsu Components America or its affiliates do not warrant that the content of datasheet is error free. In a continuing effort to improve our products Fujitsu Components America, Inc. or its affiliates reserve the right to change specifications/datasheets without prior notice. Copyright ©2017 Fujitsu Components America, Inc. All rights reserved. Revised October 20, 2017

# Mouser Electronics

Authorized Distributor

Click to View Pricing, Inventory, Delivery & Lifecycle Information:

[Fujitsu:](#)

[FWM8BLZ02A-109047](#)