



Copyright FCI.



FCIconnect.com

1 | 2

3

4

PRODUCT NUMBER  
SEE SHEET 2

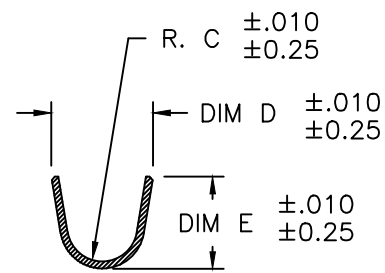

SECTION J-J  
SCALE 8:1

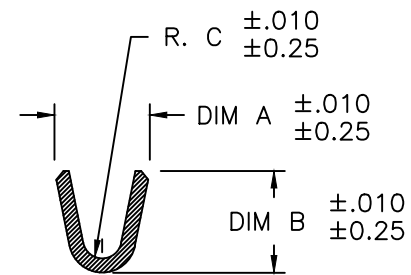

SECTION H-H  
SCALE 8:1

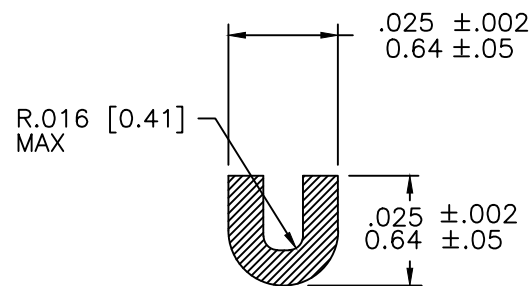

SECTION G-G  
SCALE 5:1

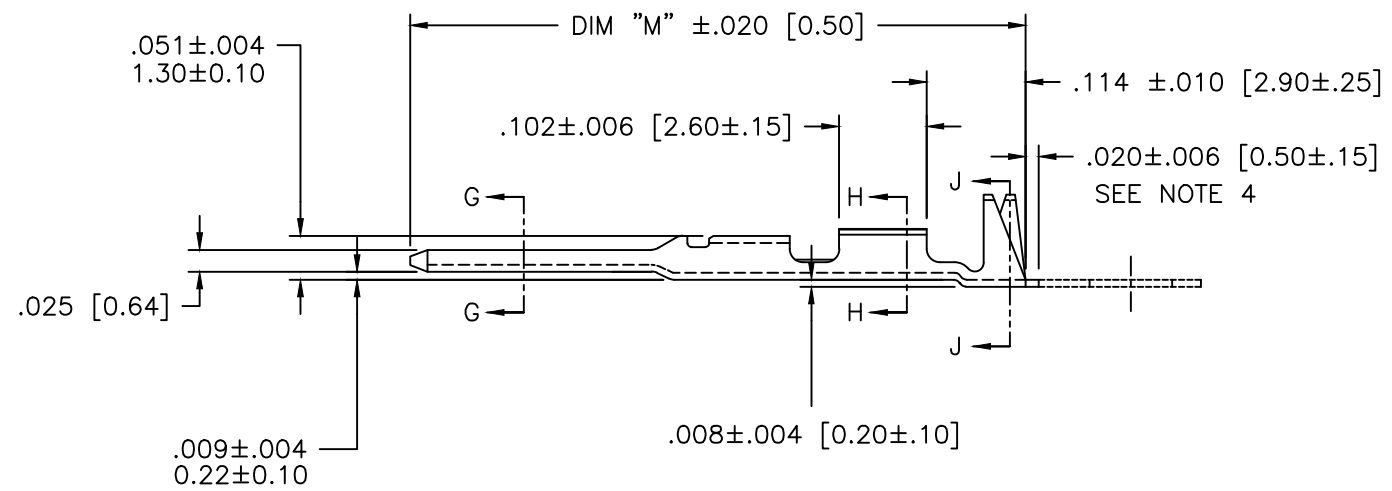
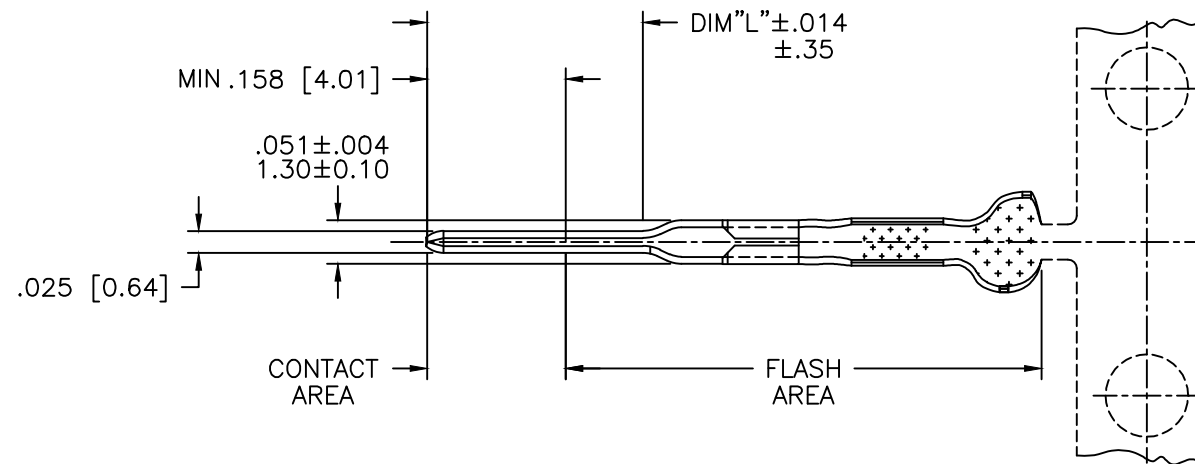

mat'l. code SEE NOTE 5		surface	tolerance	projection	product family PV TERMINALS
ltr	ecn no	dr	date	tolerances unless otherwise specified	title
T	V09-0453	HTB	2009-10-15	angles .XX ±.01/.X±.3	C.T.W. MALE PIN
U	F-25828	DDE	17-01-03	lines .XXX ±.005/.XX±.13	
				0° ±2° .XXXX ±.0020/.XXX±.05	
N	V05-0467	HTB	2005-05-23	dr	dwg no
P	V05-0530	HTB	2005-05-31	engr	75967
R	V06-0624	HTB	2006-06-30	chr	sheet 1 of 2
S	V08-0114	HTB	2008-04-01	appr	size
sheet	revision	U	U		A4
index	sheet	1	2		type
					CUSTOMER Drawing

form: A4mmXLc

1

2

3

4



PRODUCT NUMBER	AWG	WIRE BARREL			INSULATION BARREL					
		DIM "A"	DIM "B"	DIM "C"	DIM "D"	DIM "E"	DIM "F"	DIM "L"	DIM "M"	
75967-XY1		O B S O L E T E								
75967-XY1LF	28-32	.054/1.37	.058/1.47	.011/0.28	.115/2.92	.105/2.67	.040/1.02	.253/6.42	.697/17.70	
75967-XY2		O B S O L E T E								
75967-XY2LF	22-26	.070/1.78	.070/1.78	.017/0.43	.139/3.53	.120/3.05	.050/1.27	.253/6.42	.697/17.70	
75967-XY3		O B S O L E T E								
75967-XY3LF	18-20	.104/2.64	.104/2.64	.021/0.53	.139/3.53	.120/3.05	.050/1.27	.253/6.42	.697/17.70	
75967-XY7		U N A V A I L A B L E								
75967-XY8		U N A V A I L A B L E								
75967-XY9		U N A V A I L A B L E								

PRODUCT NUMBER

75967-XYZLF

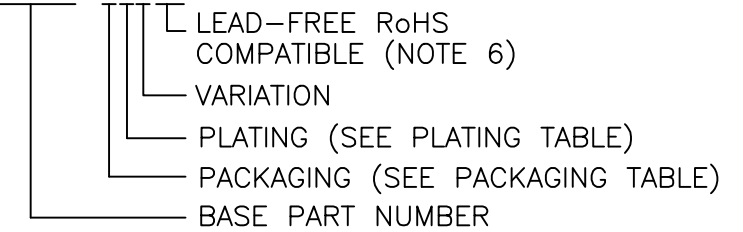

PLATING CODE	PLATING
75967-X1ZLF	30μ"/0.76μ Au IN CONTACT AREA; REMAINDER 3μ"/0.076μ Au FLASH OVER 50μ"/1.27μ Ni
75967-X2ZLF	15μ"/0.38μ Au IN CONTACT AREA; REMAINDER 3μ"/0.076μ Au FLASH OVER 50μ"/1.27μ Ni
75967-X3ZLF	50μ"/1.27μ Au IN CONTACT AREA; REMAINDER 3μ"/0.076μ Au FLASH OVER 50μ"/1.27μ Ni
75967-X6Z	O B S O L E T E
75967-X6ZLF	PRE-PLATED 100μ"/2.54μ TO 160μ"/4.06μ Sn (NOTE 8)
75967-X9ZLF	50μ"/1.27μ Au IN CONTACT AREA; REMAINDER 30μ"/0.76μ Au OVER 50μ"/1.27μ Ni

NOTES:

1. APPLICABLE SPECIFICATIONS  
BUS-12-098 PRODUCT SPECIFICATION
2. FOR PLATING SPECIFICATIONS SEE SHEET 2
3. FOR APPLICATION WITH MINI-LATCH HOUSING SEE TA-211
- ④ CUT-OFF DIMENSION FOR LOOSE PIECE VERSIONS
- ⑤ MATERIAL: BRASS ASTM B36 ALLOY C26000-H03
- ⑥ PRODUCT MEETS EUROPEAN UNION DIRECTIVES AND OTHER COUNTRY REGULATIONS AS DESCRIBED IN GS-22-008.
7. THIS PRODUCT IS NOT INTENDED TO BE EXPOSED TO MANUFACTURING SOLDER PROCESSES.
- ⑧ THIS PRODUCT HAS 100% TIN PLATING IN THE INTERFACE AND HAS NOT BEEN TESTED FOR WHISKER GROWTH IN ALL INTERCONNECT ENVIRONMENTS.

PACKAGING CODE	FINAL REELING	QUANTITY	APPLICATION INFORMATION
75967-0YZLF	LOOSE PIECE		U N A V A I L A B L E
75967-1YZLF	RIGHT TO LEFT	8000 PER REEL	APPLICATOR R. TO L. FEEDING
75967-3YZLF	LEFT TO RIGHT	8000 PER REEL	APPLICATOR L. TO R. FEEDING

mat'l. code SEE NOTE 5		surface	tolerance	projection	product family PV TERMINALS
ltr	ecn no	dr	date	tolerances unless otherwise specified	title
T				angles	C.T.W. MALE PIN
U				linear	
				0° ±2'	INCH/MM
				dr	scale 4:1
				enr	dwg no
				chr	sheet 2 of 2
				app	size
					75967
					A4
					type
					CUSTOMER Drawing
sheet index	revision sheet				