

### GENERAL DESCRIPTION

The EVAL-ADXL346Z is a simple evaluation board that allows quick evaluation of the performance of the ADXL346 3-axis digital accelerometer. The EVAL-ADXL346Z has two sets of 0.1 inch spaced vias for population of two 5-pin headers and access to all power and signal lines. The vias or headers allow the evaluation board to be attached to a prototyping board (breadboard) or to the PCB in an existing system. Four holes are provided for mechanical attachment of the EVAL-ADXL346Z to the application. An external host processor is required for communication to the part.

The dimensions of the EVAL-ADXL346Z are 20 mm  $\times$  20 mm with mounting holes set 15 mm  $\times$  15 mm at the corners of the printed circuit board (PCB).

### CIRCUIT DESCRIPTION

The schematic of the EVAL-ADXL346Z is shown in Figure 1. Refer to the [ADXL346](#) data sheet for configuration of the accelerometer after it is connected to the application host processor.

The PCB layout of the EVAL-ADXL346Z is shown in Figure 2. The EVAL-ADXL346Z has three factory installed capacitors for bypass: two 100 nF capacitors and a 10  $\mu$ F capacitor. C1, located between  $V_{DD I/O}$  and GND, is provided to reduce digital clocking noise, and C2 and C3 are  $V_S$  bypass capacitors to reduce analog supply noise.

### HANDLING CONSIDERATIONS

The EVAL-ADXL346Z is not protected against reverse polarity. Reversing the  $V_S$  or  $V_{DD I/O}$  supply and GND pins can cause damage to the ADXL346.

Dropping the EVAL-ADXL346Z on a hard surface can generate several thousand  $g$ 's of acceleration, which may exceed the data sheet absolute maximum limits. See the ADXL346 data sheet for more information.

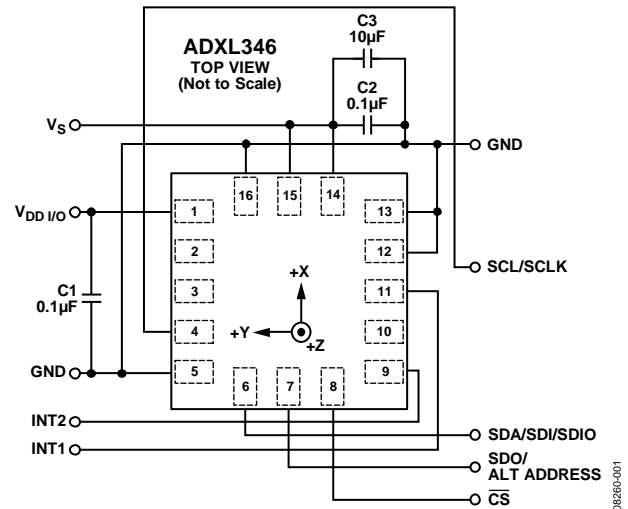
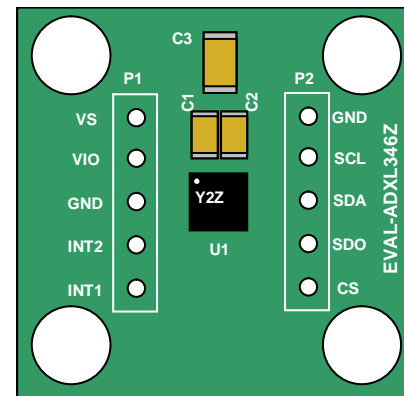

Figure 1. Schematic



NOTES  
1. PART MARKING FOR ADXL346Z IS Y2Z.

Figure 2. Physical Layout

### Rev. 0

Evaluation boards are only intended for device evaluation and not for production purposes. Evaluation boards are supplied "as is" and without warranties of any kind, express, implied, or statutory including, but not limited to, any implied warranty of merchantability or fitness for a particular purpose. No license is granted by implication or otherwise under any patents or other intellectual property by application or use of evaluation boards. Information furnished by Analog Devices is believed to be accurate and reliable. However, no responsibility is assumed by Analog Devices for its use, nor for any infringements of patents or other rights of third parties that may result from its use. Analog Devices reserves the right to change devices or specifications at any time without notice. Trademarks and registered trademarks are the property of their respective owners. Evaluation boards are not authorized to be used in life support devices or systems.

# EVAL-ADXL346Z

## ORDERING GUIDE

Model <sup>1</sup>	Package Description
EVAL-ADXL346Z	Evaluation Board

<sup>1</sup> Z = RoHS Compliant Part.

## ESD CAUTION



**ESD (electrostatic discharge) sensitive device.** Charged devices and circuit boards can discharge without detection. Although this product features patented or proprietary protection circuitry, damage may occur on devices subjected to high energy ESD. Therefore, proper ESD precautions should be taken to avoid performance degradation or loss of functionality.