

Part Numbers

Time Delay Relays

For Mounting on any 2* or 3-Port Subbase
Using Atmospheric Air for Control
Single Turn Adjustment

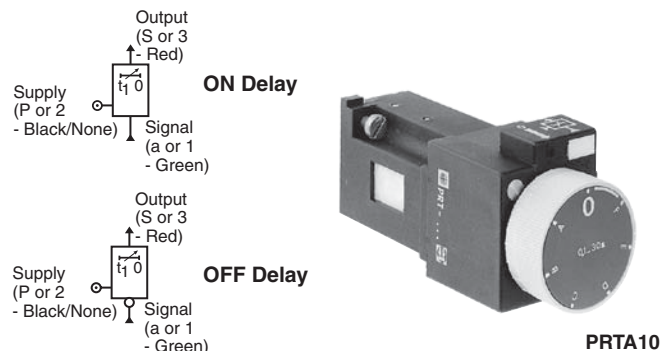

*Function Must Be Checked.

Part Number	Description	Timing Range
PRTE10	ON Delay	0.1 to 3 sec.
PRTA10	ON Delay	0.1 to 30 sec.
PRTB10	ON Delay	10 to 180 sec.
PRTF10	OFF Delay	0.1 to 3 sec.
PRTC10	OFF Delay	0.1 to 30 sec.
PRTD10	OFF Delay	10 to 180 sec.
PRTA12	PRTA10 on PZUA12 Subbase	
LA9D901	Tamperproof Cap	

The Time Delay Relay delays a maintained input signal during an adjustable time period after which a regenerated output appears.

Setting

- Delay is set by turning knob.
- One 360° turn covers complete timing range.
- When white line on dial is set at top dead center, TDR goes to infinity. This feature facilitates machine set up.

Connections: 3-Port Subbase with

- Instant Straight Connections
- Instant Swivel Connections
- 1/8" NPT Female Connections

Timing Functions

• Positive Output

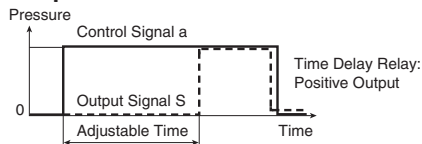

• Inverted Output

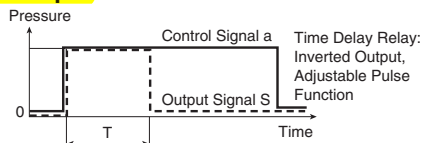

Repeatability +2%

Specifications

Air Quality -

Standard Shop Air, Lubricated or Dry, 40 µm Filtration

Cv0.14 (1.8)

Filter a-PPRL23, Vent - PPRL20

Flow rate at 90 PSI (6 bar) in SCFM (l/mn ANR)....6.4 (180)

Interchangeable 50 µm Filter -

a (Input).....PPRL23

Input Cylinder.....PPRL20

Materials -

- Body.....Polyamide
- Poppet.....Polyurethane
- Seals.....Nitrile (Buna N)

Mounting 2 or 3-Port Subbase

Number of Operations with Dry Air at 90 PSI and 70°F,
Frequency 1 Hz 10 Million

Operating Positions..... All

Operating Pressure 40 to 115 PSIG (3 to 8 bar)

Repeatability ±5% / 5 Operations

Response Time 2 to 3 msec

Temperature -

Operating 32°F to 122°F (0°C to +50°C)

Storage -22°F to 140°F (-30°C to +60°C)

Tamperproof Cap

- **Locking**
Set desired time delay, then place transparent cap over setting knob and tighten screw.
- **Sealing**
Bend tab over screw head; run wire over head, then seal.

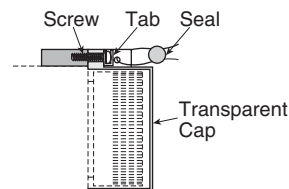

Dimensions

PRT•10

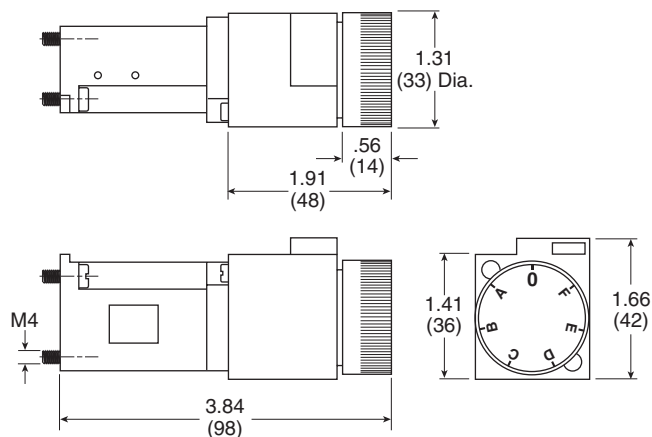

A

Operating Principle

The time delay relay is entirely pneumatic. Air supply to the timing head is taken from the ambient atmosphere. The timing function is therefore independent of line pressure. As a result, repeatability is unaffected by variations in supply pressure, temperature or contamination of supply. In the

positive output version, output is provided by a YES relay. In the inverted version, Output is provided by a NOT relay.

Note: Piping inverted TDR for adjustable pulse function: Tee off input "a" to supply port as shown on diagram.

Time Delay Relay Operating Principle: On Delay Positive Output

• SET

Signal "a" appears at input orifice in subbase and is divided into two separate signals after filter ①. The first signal cocks the piston ② and timing begins.

Simultaneously the second divided signal flows through fixed orifice ③ and supplies bleed at orifice ④.

• TIMING

Poppet ⑤, attached to bellows ⑦ and released by piston ②, starts to extend at a rate determined by the amount of delay required. Bellows ⑦ rate of extension is controlled as follows:

- Spring ⑥ pushed bellows out. To extend, bellows draws atmosphere air through filter ⑧ and circular channel ⑨. Length of channel ⑨ varies as a function of angle, determined by knob ⑩.

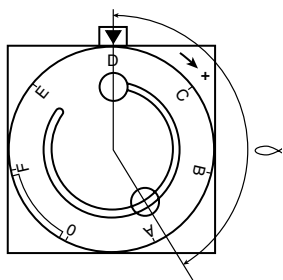

The greater the angle, the longer the time delay.

• OUTPUT

When bellows ⑦ reaches the end of its travel, poppet ⑤ seals off bleed from orifice ④, causing a rise in pressure and as a result output relay switches. Output S appears, supplied by pressure P.

• RESET

Removing the signal "a" automatically resets the time delay relay. Output S disappears.

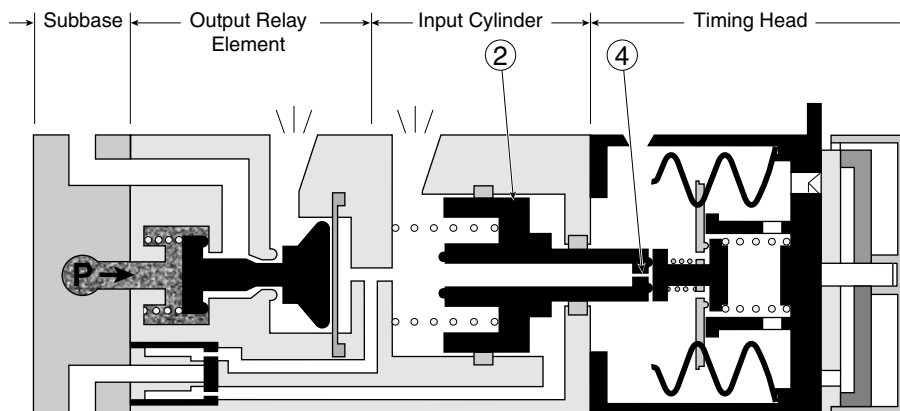

Unactuated State (Before Timing)

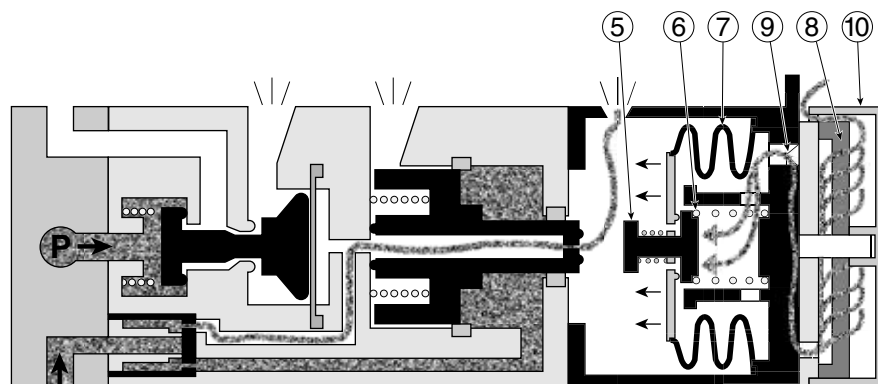

State During Timing

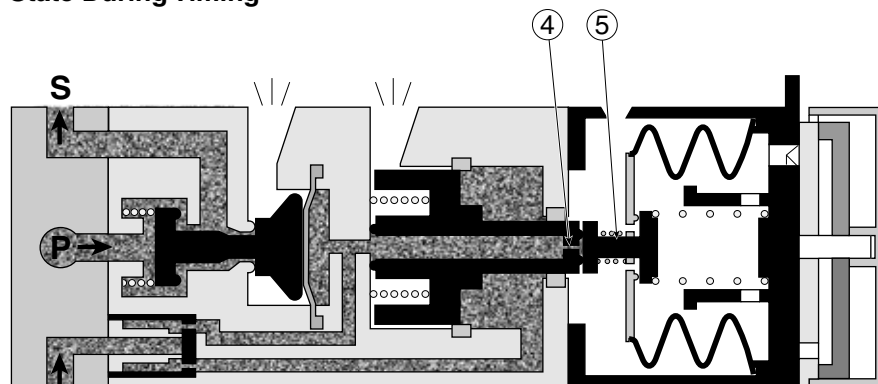

Actuated State (After Timing)

Adjustable Pulse Output Timer

Maintained input generates adjustable pulse output. When maintained input "a" goes ON, output S goes ON then drops OFF after an adjustable time period T even though "a" is still on.

Maintained input "a" provides an adjustable pulse output using inverted TDR.

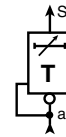
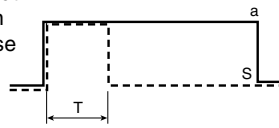

Single Adjustable Pulse Output Timer

Momentary input generates single adjustable pulse output (one shot). This circuit is useful when a brief signal needs to be prolonged, for example, rapidly actuated limit switches.

Momentary input "a" generates longer output S. After adjustable time period T, the inverted TDR cuts off output S.

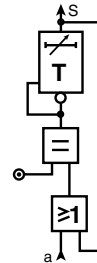
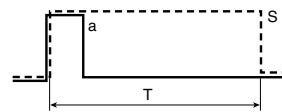

Adjustable Reciprocate Output Timer

Maintained input generates repeated pulse output (clock signal). Maintained input "a" generates continuously repeated pulse output S.

- The time duration of pulse S is adjustable separately.
- The time between pulses is adjustable separately.

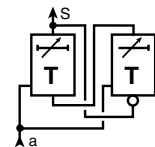
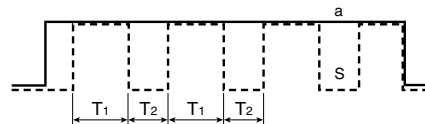

Memory Operation

• OFF

Held in position by magnet ②, Poppet ① closes off supply pressure P.

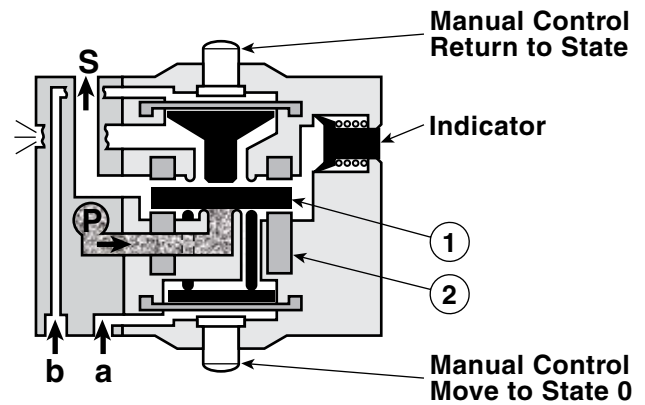

• SET

Input signal "a" acting on a diaphragm drives poppet ① from magnet ② to magnet ③ allowing pressure to flow. Output signal S appears as indicated by position indicator ④.

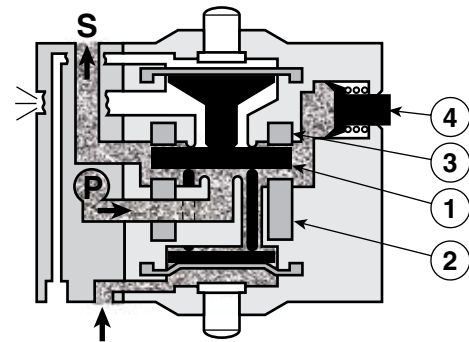

• ON

When input "a" is removed, output S is maintained since magnet ③ holds poppet ① seated.

Note: If pressure is lost, the last MEMORY will maintain its last position.

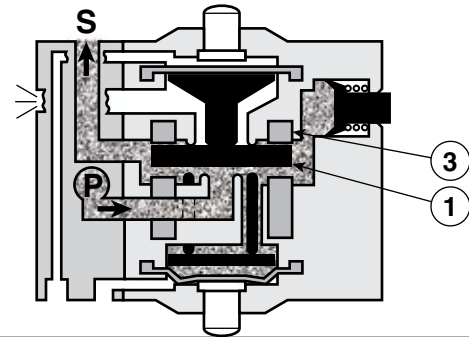

• RESET

Input "b" acting on the opposite diaphragm returns poppet ① to magnet ②. Output S is removed and exhausted to atmosphere.

