

## CMOS quad 3-state differential line receiver

Datasheet - production data

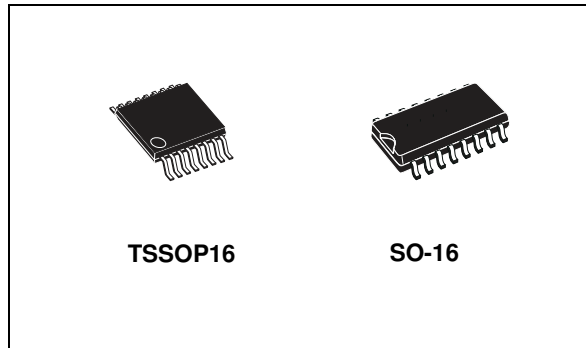

The ST26C32AB has an input sensitivity of 200 mV over the common mode input voltage range of  $\pm 7$  V. The ST26C32AB features internal pull-up and pull-down resistors which prevent output oscillation on unused channels. The ST26C32AB provides an enable and disable function to all four receivers and features 3-state output with 6 mA source and sink capability.

### Features

- CMOS design for low power
- $\pm 0.2$  V sensitivity over input common mode voltage range
- Typical propagation delay: 19 ns
- Typical input hysteresis: 60 mV
- Input will not load line when  $V_{CC} = 0$  V
- Meets the requirements of EIA standard RS-422, RS-423
- 3-state outputs for connection to system buses
- Available in surface mount

### Description

The ST26C32AB is a quad differential line receiver designed to meet the RS-422, RS-423 standards for balanced and unbalanced digital data transmission, while retaining the low power characteristics of CMOS.

Table 1. Device summary

Order codes	Temperature range	Package	Packaging
ST26C32ABDR	-40 to 85 °C	SO-16 (tape and reel)	2500 parts per reel
ST26C32ABTR	-40 to 85 °C	TSSOP16 (tape and reel)	2500 parts per reel

# Contents

1	Pin configuration .....	3
2	Maximum ratings .....	5
3	Electrical characteristics .....	6
4	Package mechanical data .....	7
5	Revision history .....	12



# 1 Pin configuration

Figure 1. Pin connections

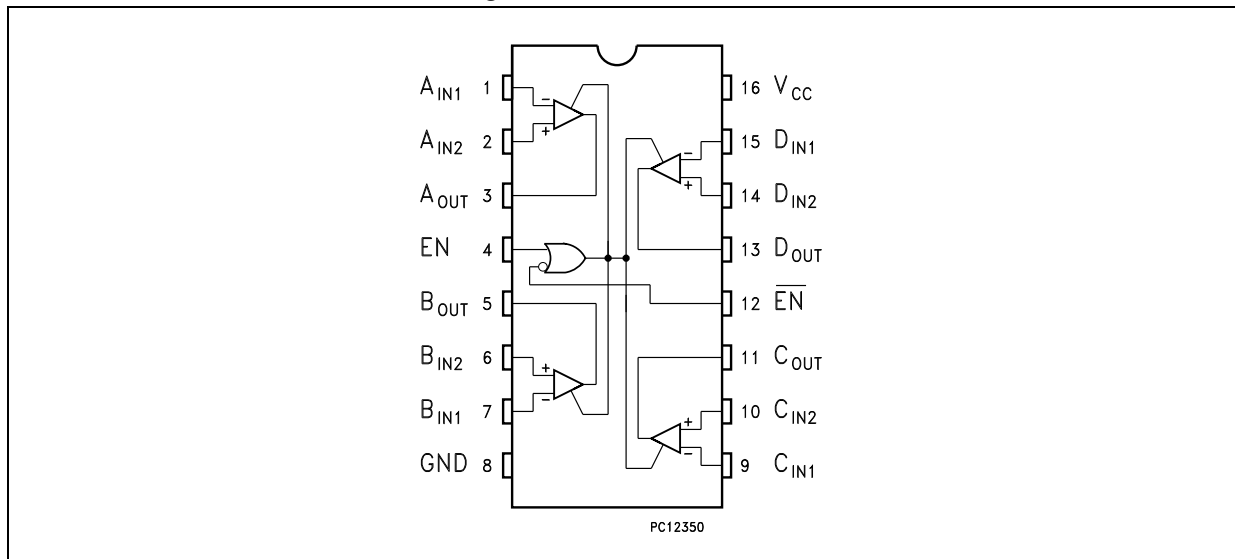

Table 2. Pin description

Pin n°	Symbol	Name and function
1	A <sub>IN1</sub>	Input A1
2	A <sub>IN2</sub>	Input A2
3	A <sub>OUT</sub>	Channel A Output
4	EN	ENABLE
5	B <sub>OUT</sub>	Channel B Output
6	B <sub>IN2</sub>	Input B2
7	B <sub>IN1</sub>	Input B1
8	GND	Ground
9	C <sub>IN1</sub>	Input C1
10	C <sub>IN2</sub>	Input C2
11	C <sub>OUT</sub>	Channel C output
12	EN	ENABLE
13	D <sub>OUT</sub>	Channel D output
14	D <sub>IN2</sub>	Input D2
15	D <sub>IN1</sub>	Input D1
16	V <sub>CC</sub>	Supply voltage

Table 3. Truth table

Enable	Enable	Input	Output
L	H	X	Z
All other combinations of enable inputs		$V_{ID} \geq V_{TH(MAX)}$	H
		$V_{ID} \leq V_{TH(MIN)}$	L
		Open	H

Note: *L = Low voltage state*  
*H = High logic state*  
*X = Don't care*  
*Z = High impedance*

## 2 Maximum ratings

**Table 4. Absolute maximum ratings** (1) (2)

Symbol	Parameter	Value	Unit
$V_{CC}$	Supply voltage	7	V
$V_{CM}$	Input common mode range	$\pm 14$	V
$V_{DIFF}$	Differential input voltage	$\pm 14$	V
$V_{IN}$	Enable input voltage	7	V
$I_{OMAX}$	Maximum current per output	$\pm 25$	mA
$T_{STG}$	Storage temperature range	-65 to +150	°C

1. Absolute maximum ratings are those values beyond which the safety of the device cannot be guaranteed. They are not meant to imply that the device should be operated at these limits. The table of electrical characteristics provide conditions for actual device operation.
2. Unless otherwise specified, all voltage are referenced to ground. All currents into the device pins are positive; all currents out of the device pins are negative.

**Table 5. Recommended operating conditions**

Symbol	Parameter	Value	Unit
$V_{CC}$	Supply voltage	4.5 to 5.5	V
$T_A$	Operating temperature range	-40 to +85	°C
$t_r, t_f$	Maximum enable input rise or fall times	500	ns

### 3 Electrical characteristics

**Table 6. Electrical characteristics** ( $V_{CC} = 5\text{ V} \pm 10\%$ , unless otherwise specified <sup>(1)</sup>)

Symbol	Parameter	Test conditions	Value			Unit
			Min.	Typ.	Max.	
$V_{TH}$	Minimum differential input voltage	$V_{OUT} = V_{OH}$ or $V_{OL}$ , $-7\text{V} < V_{CM} < 7\text{V}$	-200	35	200	mV
$R_{IN}$	Input resistance	$V_{IN} = -7\text{V}$ , $7\text{V}$ , other input = GND	5	6.8	10	k $\Omega$
$I_{IN}$	Input current	$V_{IN} = 10\text{V}$ , other input = GND		1.1	1.5	mA
		$V_{IN} = -10\text{V}$ , other input = GND		-2	-2.5	
$V_{OH}$	High level output voltage	$V_{DIFF} = 1\text{V}$ , $I_{OUT} = -6\text{mA}$	3.8	4.2		V
$V_{OL}$	Low level output voltage	$V_{DIFF} = -1\text{V}$ , $I_{OUT} = 6\text{mA}$		0.2	0.3	V
$V_{IH}$	Minimum enable high input level voltage		2			V
$V_{IL}$	Minimum enable low input level voltage				0.8	V
$I_{OZ}$	3-state output leakage current	$V_{OUT} = V_{CC}$ or GND $ENABLE = V_{IL}$ , $ENABLE = V_{IH}$		$\pm 0.5$	$\pm 5$	$\mu\text{A}$
$I_I$	Maximum enable input current	$V_{IN} = V_{CC}$ or GND			$\pm 1$	$\mu\text{A}$
$I_{CC}$	Quiescent power supply current	$V_{CC} = \text{Max}$ , $V_{(DIFF)} = 1\text{V}$		16	23	mA
$V_{HYST}$	Input hysteresis	$V_{CM} = 0\text{V}$		60		mV

1. Unless otherwise specified, min./max. limits apply across the recommended operating temperature range. All typical are given for  $V_{CC} = 5\text{ V}$  and  $T_A = 25\text{ }^\circ\text{C}$

**Table 7. Switching characteristics** ( $V_{CC} = 5\text{ V} \pm 10\%$ , <sup>(1)</sup>)

Symbol	Parameter	Test conditions	Value			Unit
			Min.	Typ.	Max.	
$t_{PLH}$ $t_{PHL}$	Propagation delay input to output	$C_L = 50\text{pF}$ , $V_{DIFF} = 2.5\text{V}$ , $V_{CM} = 0\text{V}$		19	30	ns
$t_{RISE}$ $t_{FALL}$	Output rise and fall times	$C_L = 50\text{pF}$ , $V_{DIFF} = 2.5\text{V}$ , $V_{CM} = 0\text{V}$		4	9	ns
$t_{PZH}$ $t_{PZL}$	Propagation enable time to output	$C_L = 50\text{pF}$ , $V_{DIFF} = 2.5\text{V}$ , $R_L = 1000\Omega$		13	23	ns
$t_{PHZ}$ $t_{PLZ}$	Propagation disable time to output	$C_L = 50\text{pF}$ , $V_{DIFF} = 2.5\text{V}$ , $R_L = 1000\Omega$		13	22	ns
$D_R$	Data rate	$C_L = 50\text{pF}$ , $V_{DIFF} = 2.5\text{V}$ All outputs loaded and switching	10	20		Mbits/s

1. Unless otherwise specified, min./max. limits apply across the recommended operating temperature range. All typical are given for  $V_{CC} = 5\text{ V}$  and  $T_A = 25\text{ }^\circ\text{C}$

## 4 Package mechanical data

In order to meet environmental requirements, ST offers these devices in different grades of ECOPACK packages, depending on their level of environmental compliance. ECOPACK specifications, grade definitions and product status are available at: [www.st.com](http://www.st.com). ECOPACK is an ST trademark.

**SO-16 mechanical data**

Dim.	mm.			inch.		
	Min.	Typ.	Max.	Min.	Typ.	Max.
A			1.75			0.068
a1	0.1		0.25	0.004		0.010
a2			1.64			0.063
b	0.35		0.46	0.013		0.018
b1	0.19		0.25	0.007		0.010
C		0.5			0.019	
c1	45° (typ.)					
D	9.8		10	0.385		0.393
E	5.8		6.2	0.228		0.244
e		1.27			0.050	
e3		8.89			0.350	
F	3.8		4.0	0.149		0.157
G	4.6		5.3	0.181		0.208
L	0.5		1.27	0.019		0.050
M			0.62			0.024
S	8° (max.)					

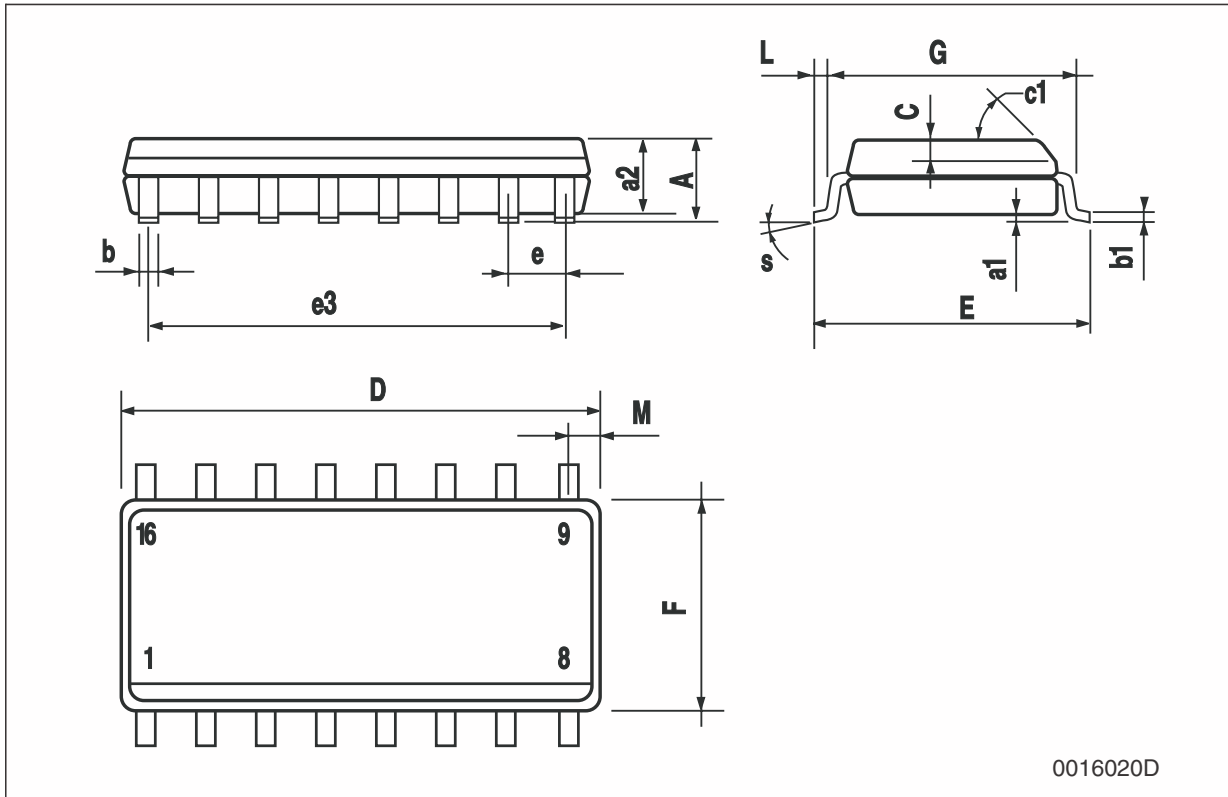

0016020D





**TSSOP16 mechanical data**

Dim.	mm.			inch.		
	Min.	Typ.	Max.	Min.	Typ.	Max.
A			1.2			0.047
A1	0.05		0.15	0.002	0.004	0.006
A2	0.8	1	1.05	0.031	0.039	0.041
b	0.19		0.30	0.007		0.012
c	0.09		0.20	0.004		0.0079
D	4.9	5	5.1	0.193	0.197	0.201
E	6.2	6.4	6.6	0.244	0.252	0.260
E1	4.3	4.4	4.48	0.169	0.173	0.176
e		0.65 BSC			0.0256 BSC	
K	0°		8°	0°		8°
L	0.45	0.60	0.75	0.018	0.024	0.030

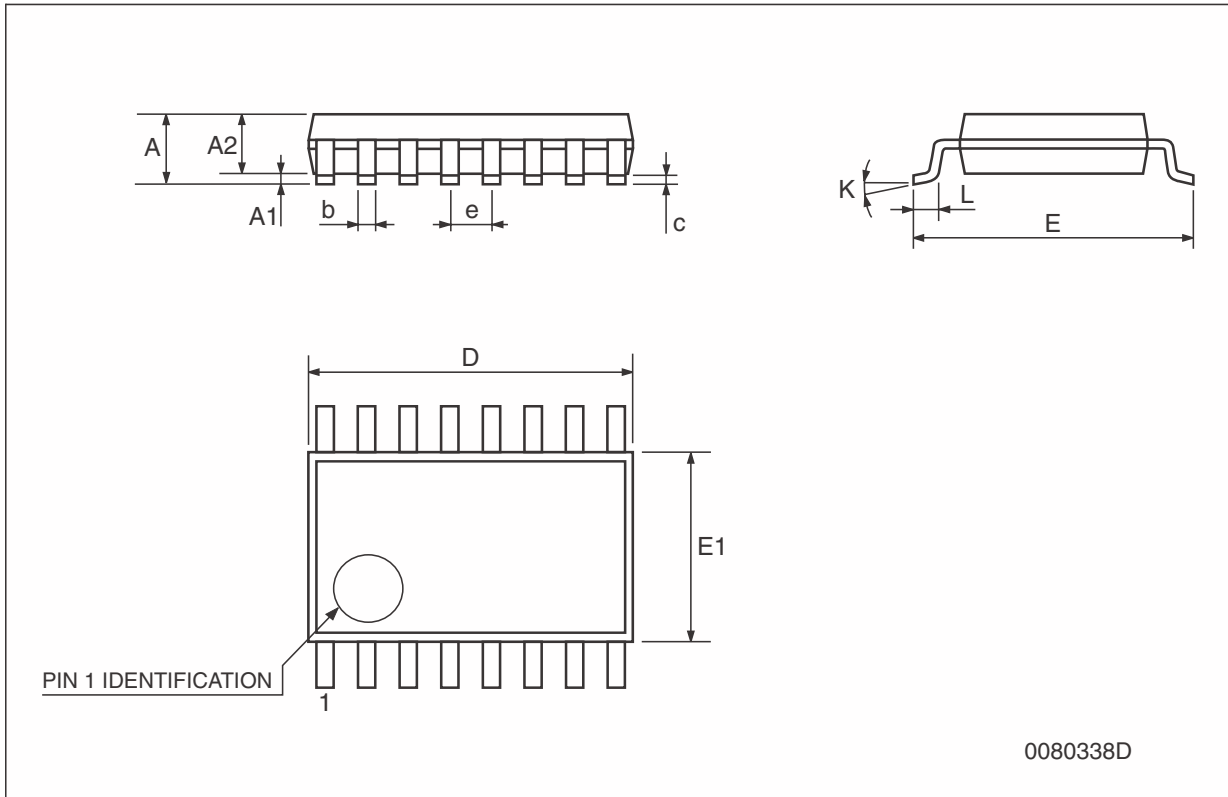

**Tape & reel SO-16 mechanical data**

Dim.	mm.			inch.		
	Min.	Typ.	Max.	Min.	Typ.	Max.
A			330			12.992
C	12.8		13.2	0.504		0.519
D	20.2			0.795		
N	60			2.362		
T			22.4			0.882
Ao	6.45		6.65	0.254		0.262
Bo	10.3		10.5	0.406		0.414
Ko	2.1		2.3	0.082		0.090
Po	3.9		4.1	0.153		0.161
P	7.9		8.1	0.311		0.319

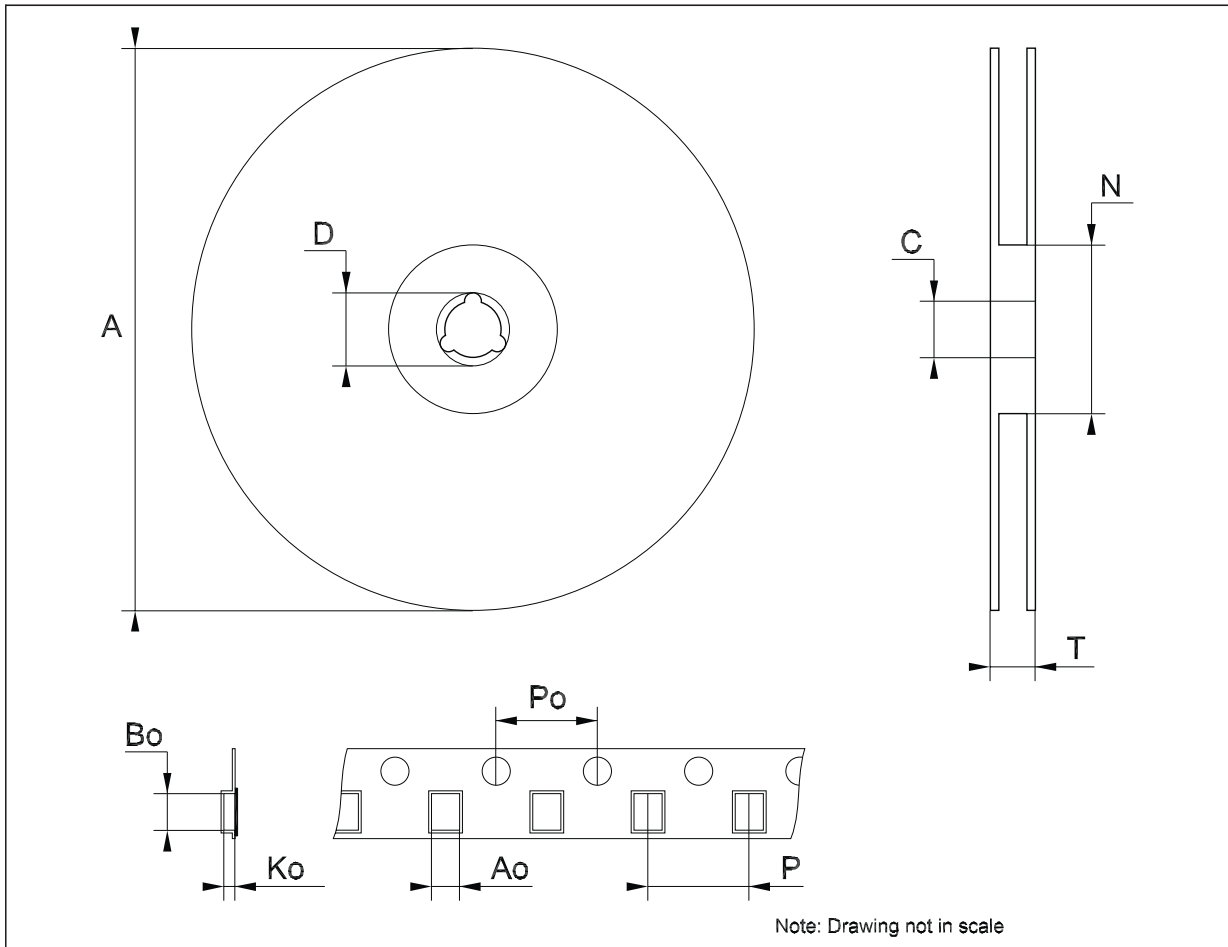

**Tape & reel TSSOP16 mechanical data**

Dim.	mm.			inch.		
	Min.	Typ.	Max.	Min.	Typ.	Max.
A			330			12.992
C	12.8		13.2	0.504		0.519
D	20.2			0.795		
N	60			2.362		
T			22.4			0.882
Ao	6.7		6.9	0.264		0.272
Bo	5.3		5.5	0.209		0.217
Ko	1.6		1.8	0.063		0.071
Po	3.9		4.1	0.153		0.161
P	7.9		8.1	0.311		0.319

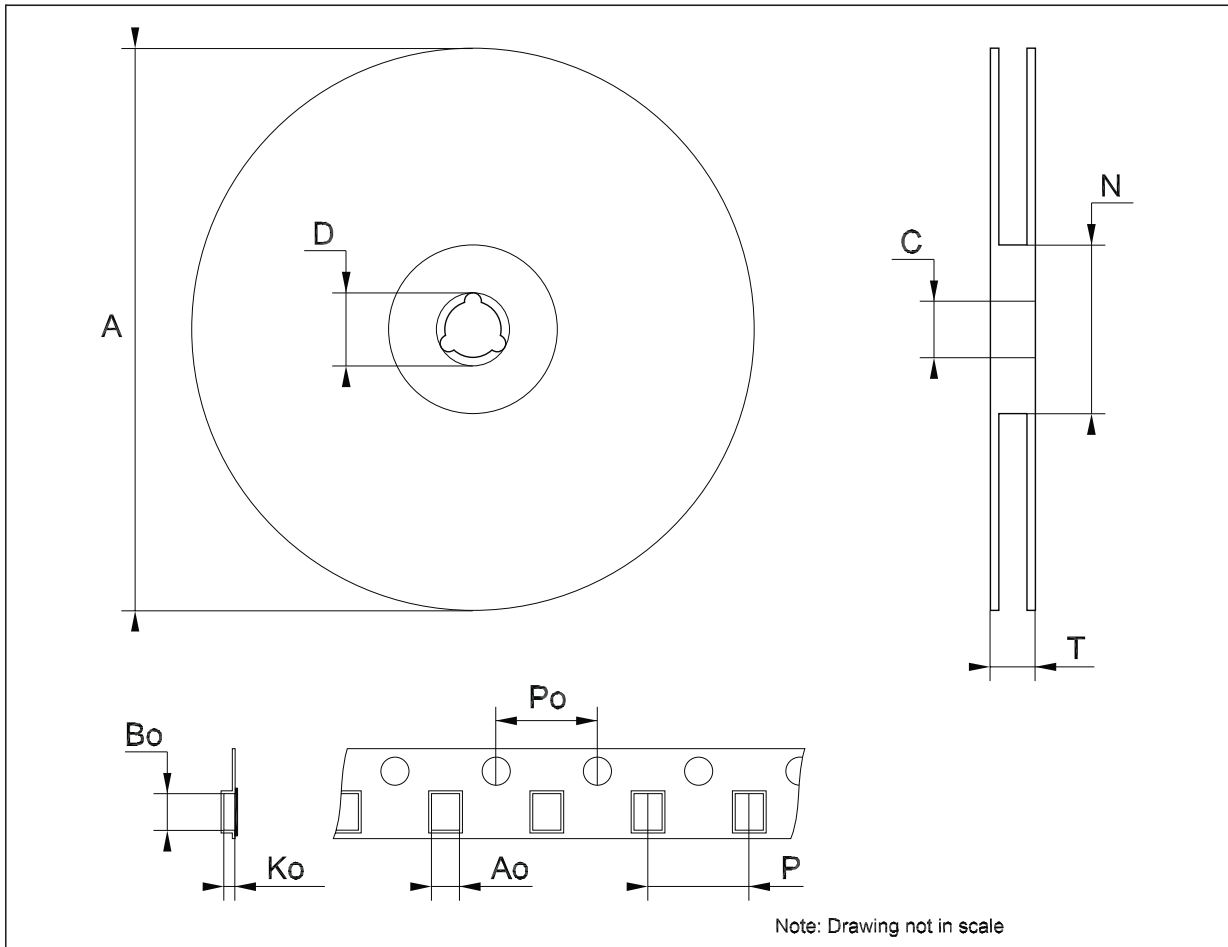

## 5 Revision history

Table 8. Document revision history

Date	Revision	Changes
02-May-2006	3	Order codes updated.
12-Jun-2008	4	Added: <a href="#">Table 1 on page 1</a> .
02-Sep-2022	5	Removed: DIP-16 package. Updated: <a href="#">Table 1</a> .

**IMPORTANT NOTICE – PLEASE READ CAREFULLY**

STMicroelectronics NV and its subsidiaries (“ST”) reserve the right to make changes, corrections, enhancements, modifications, and improvements to ST products and/or to this document at any time without notice. Purchasers should obtain the latest relevant information on ST products before placing orders. ST products are sold pursuant to ST’s terms and conditions of sale in place at the time of order acknowledgement.

Purchasers are solely responsible for the choice, selection, and use of ST products and ST assumes no liability for application assistance or the design of Purchasers’ products.

No license, express or implied, to any intellectual property right is granted by ST herein.

Resale of ST products with provisions different from the information set forth herein shall void any warranty granted by ST for such product.

ST and the ST logo are trademarks of ST. For additional information about ST trademarks, please refer to [www.st.com/trademarks](http://www.st.com/trademarks). All other product or service names are the property of their respective owners.

Information in this document supersedes and replaces information previously supplied in any prior versions of this document.

© 2022 STMicroelectronics – All rights reserved

