

SURFACE MOUNT LED WHITE, 1204 PACKAGE

BIVAR

SM1204UWC

- ◆ Industry Standard 1204 Package
- ◆ RoHS Compliant
- ◆ Right Angle Mounting
- ◆ Diffused Lens
- ◆ Wide Viewing Angle
- ◆ Ideal for Status Indication and Display

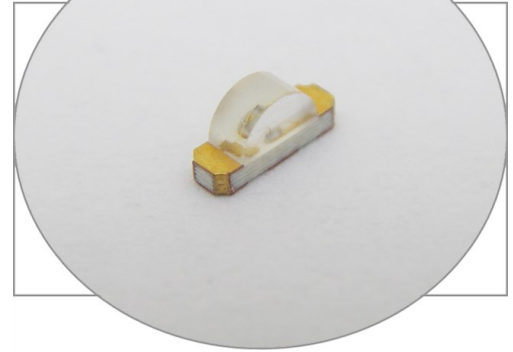

Bivar Surface Mount 1204 package LED may be used in nearly any indication application. The right angle package is ideal for small scale applications such as edge lighting or general indication. Low power consumption and excellent long life reliability are ideal for battery powered equipment. Bivar offers diffused LED lens for uniform light output. Wide variety of wavelength and intensity combinations are available to meet any illumination need. The SM1204 LED is packaged in standard tape and reels for pick and place assemblies.

Part Number	Material	Emitted Color	Chromaticity Coordinates	Lens Appearance	Luminous Intensity (mcd) TYP.	Viewing Angle
SM1204UWC	InGaN	WHITE	X = .30, Y = .30	Diffused	450	110°

Outline Dimensions

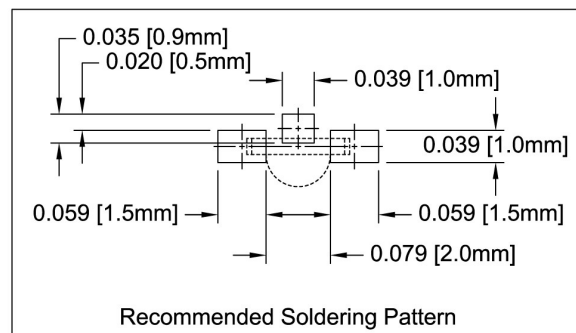
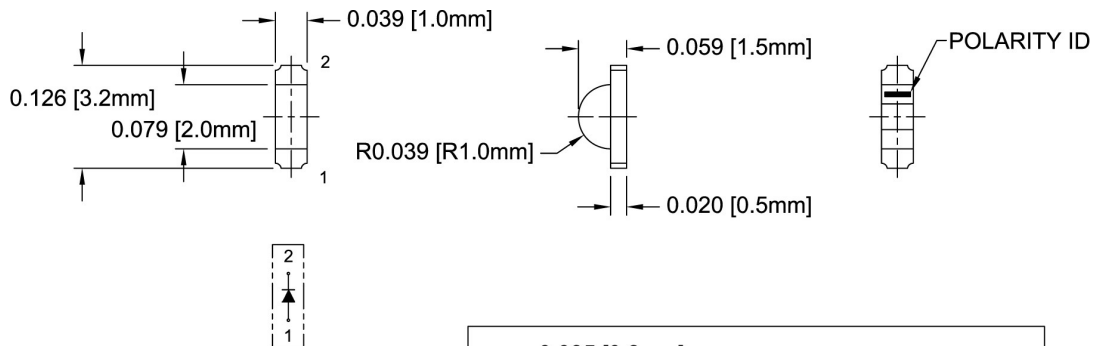

Outline Drawings Notes:

1. All dimensions are in inches [millimeters].
2. Standard tolerance: ± 0.010 " unless otherwise noted.



Bivar reserves the right to make changes at any time without notice.

Absolute Maximum Ratings

$T_A = 25^\circ\text{C}$ unless otherwise noted

Power Dissipation	100 mW
Forward Current (DC)	25 mA
Peak Forward Current ¹	100 mA
Reverse Voltage	5 V
Operating Temperature Range	-30 ~ +80°C
Storage Temperature Range	-40 ~ +85°C
Lead Soldering Temperature (3 mm from the base of the epoxy bulb) ²	260°C

Notes: 1. 10% Duty Cycle, Pulse Width \leq 0.1 msec. 2. Solder time less than 5 seconds at temperature extreme.

Electrical / Optical Characteristics

$T_A = 25^\circ\text{C}$ & $I_F = 20$ mA unless otherwise noted

Part Number	Forward Voltage (V) ¹			Recommend Forward Current (mA)			Reverse Current (μA)	Dominant Wavelength (nm) ²			Luminous Intensity I_v (mcd)			Viewing Angle $2\theta_{1/2}$ (deg)
	MIN	TYP	MAX	MIN	TYP	MAX	MAX	MIN	TYP	MAX	MIN	TYP	MAX	TYP
SM1204UWC	/	3.3	4.2	/	20	/	10	n/a	n/a	n/a	285	450	/	110

Notes: 1. Tolerance of forward voltage : $\pm 0.05\text{V}$. 2. Tolerance of dominant wavelength : $\pm 1.0\text{nm}$.

SURFACE MOUNT LED WHITE, 1204 PACKAGE



Typical Electrical / Optical Characteristics

$T_A = 25^\circ\text{C}$ unless otherwise noted

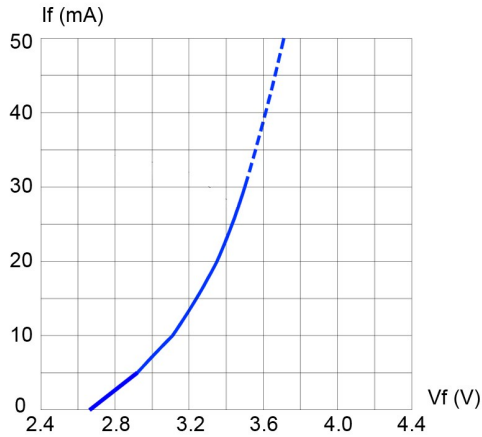

Fig. 1 Forward Current vs. Forward Voltage

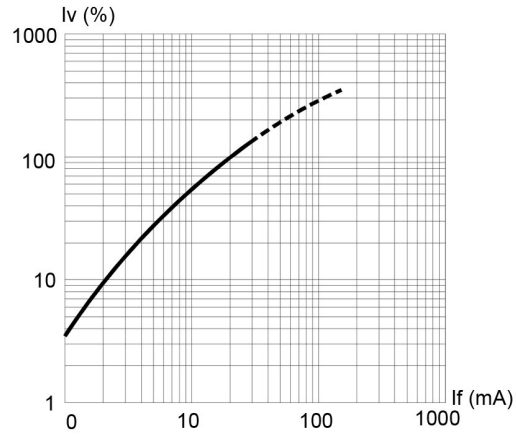

Fig. 2 Relative Luminous Intensity vs. Forward Current

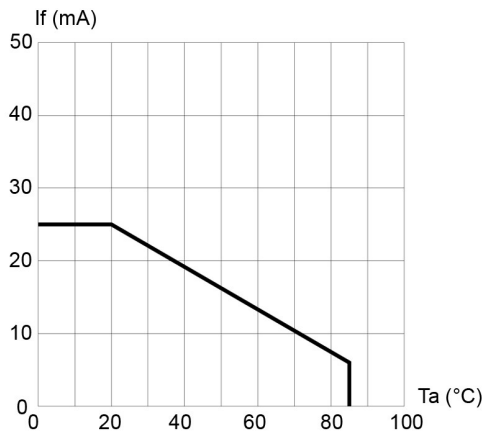

Fig. 3 Forward Current vs. Temperature

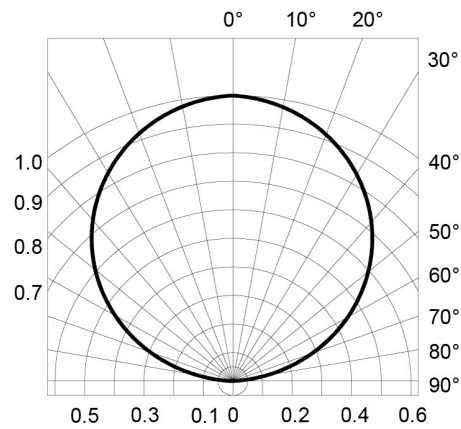

Fig. 4 Directivity Radiation Diagram

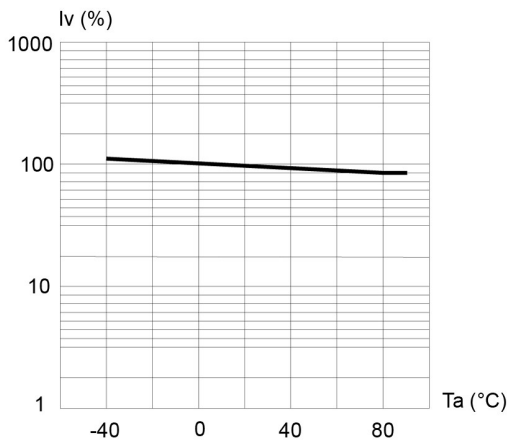

Fig. 5 Relative Luminous Intensity vs. Ambient Temperature

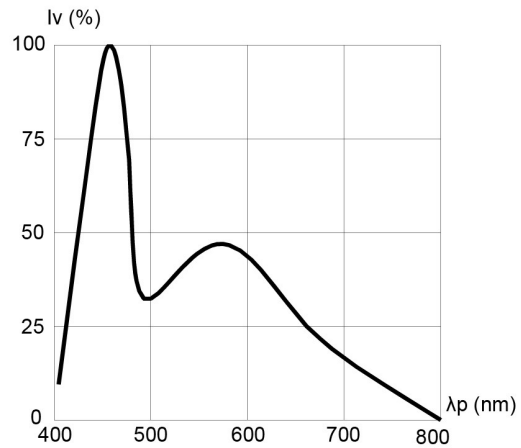

Fig. 6 Relative Luminous Intensity vs. Wavelength

Bivar reserves the right to make changes at any time without notice.

SURFACE MOUNT LED WHITE, 1204 PACKAGE



Recommended Soldering Conditions

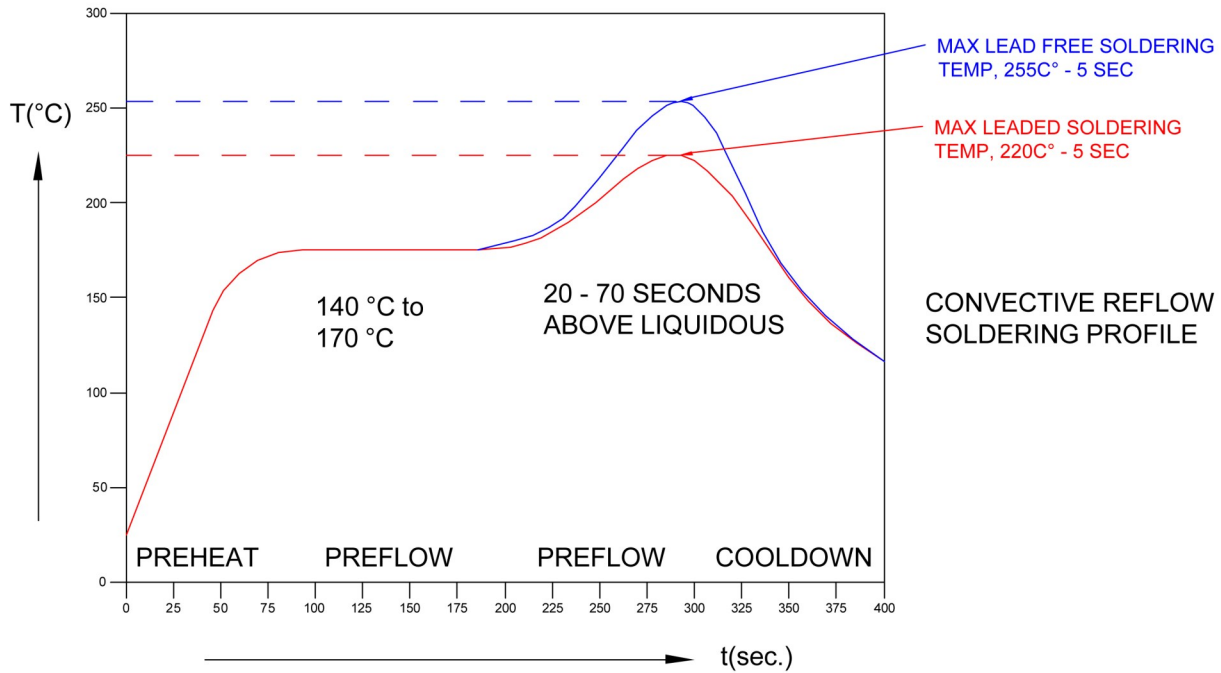

Tape and Reel Dimensions

Note: 3000 PCS/Reel

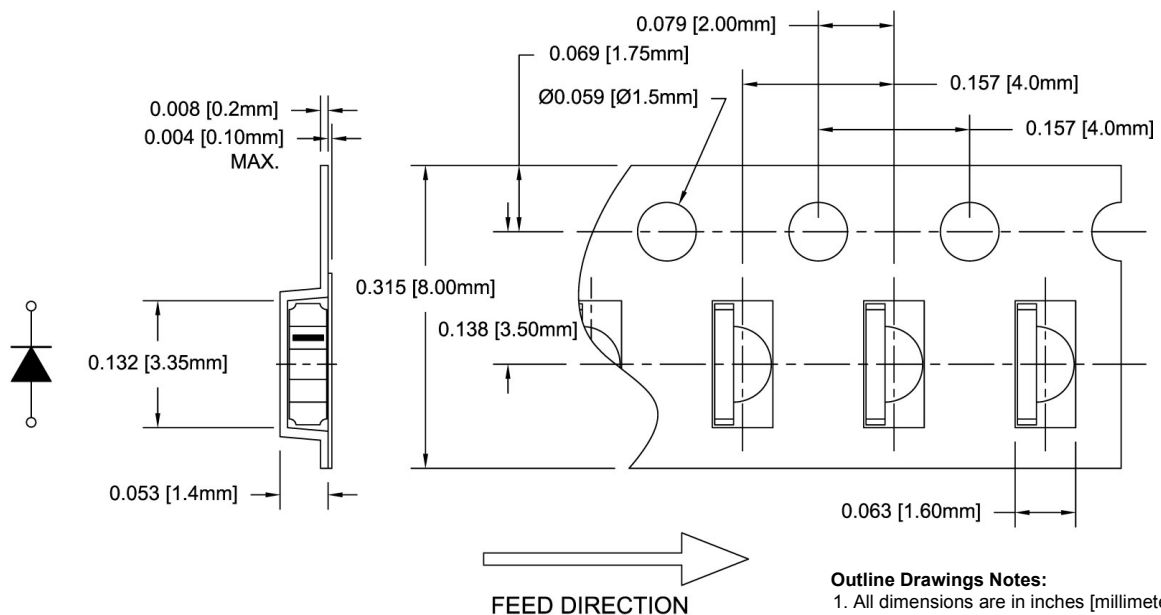

Outline Drawings Notes:

1. All dimensions are in inches [millimeters].
2. Standard tolerance: $\pm 0.010''$ unless otherwise noted.

Bivar reserves the right to make changes at any time without notice.

SURFACE MOUNT LED WHITE, 1204 PACKAGE

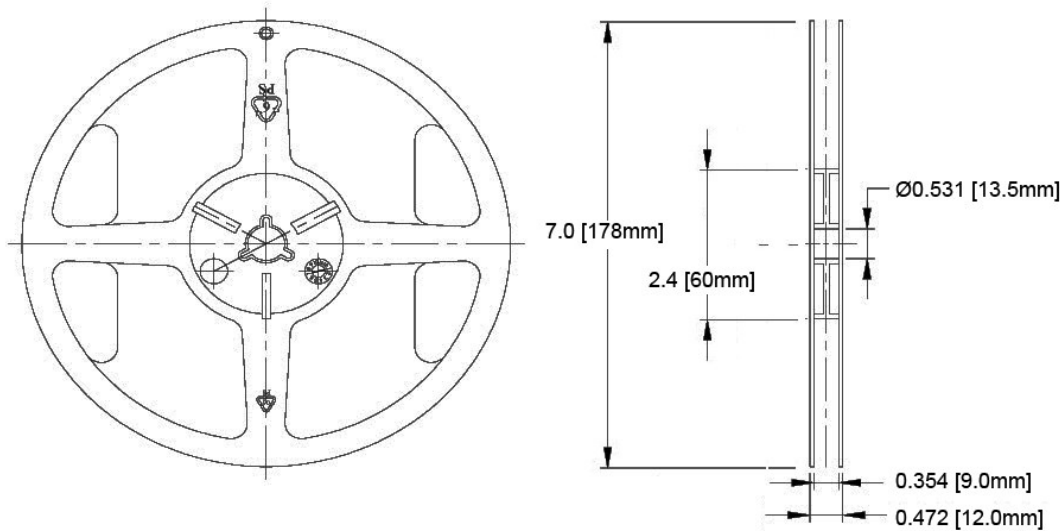

Outline Drawings Notes:

1. All dimensions are in inches [millimeters].
2. Standard tolerance unless otherwise noted: X.XXX ± 0.010"
X.X ± 0.1"

Packaging and Labeling Plan

Note: 1 Reel / Bag

Vacuum and Heat Sealed
Clear AntiStatic Poly Bag

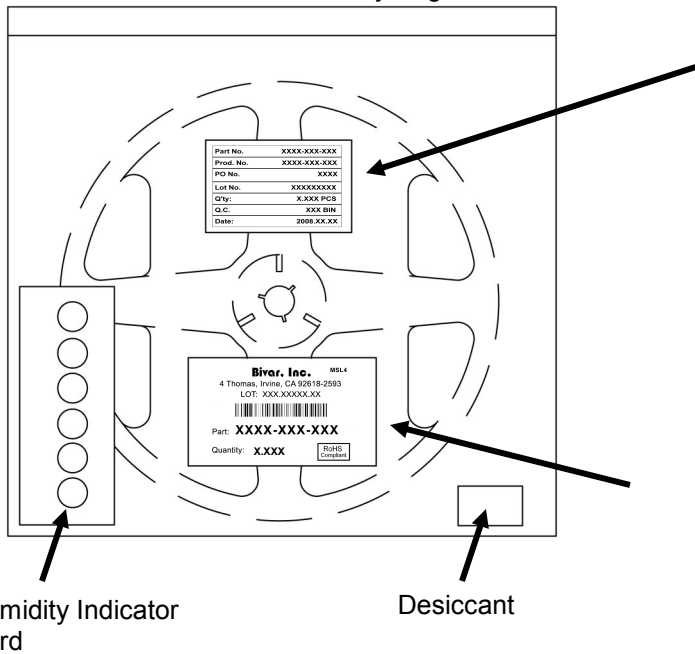

Part No.	XXXX-XXX-XXX
Prod. No.	XXXX-XXX-XXX
PO No.	XXXX
Lot No.	XXXXXXXXXX
Q'ty:	X.XXX PCS
Q.C.	XXX BIN
Date:	2008.XX.XX

Internal Quality Control

Bivar, Inc. MSL4

4 Thomas, Irvine, CA 92618-2593
LOT: XXX.XXXXX.XX



Part: **XXXX-XXX-XXX**

Quantity: **X.XXX**

RoHS
Compliant

Bivar Standard Packaging Label

Bivar reserves the right to make changes at any time without notice.