

Rittal – The System.

Faster – better – everywhere.

Roof-mounted fan



SK 3138000

SK 3139100

SK 3139110

SK 3140100

SK 3140110

SK 3140140

SK 3140500

SK 3140510

Assembly and installation instructions

ENCLOSURES

POWER DISTRIBUTION

CLIMATE CONTROL

IT INFRASTRUCTURE

SOFTWARE & SERVICES

FRIEDHELM LOH GROUP



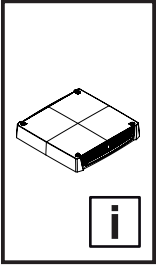

Contents

1. Safety instructions	3
1.1 Safety instructions	3
1.2 Intended use	3
2. Product description	4
2.1 Components	4
2.2 Scope of supply	5
2.3 Function	6
2.3.1 General	6
2.3.2 Safety devices	6
2.3.3 Filter mats	6
3. Mounting	7
3.1 Choosing the installation site	7
3.2 Notes on installation	7
3.2.1 General	7
3.2.2 Layout of the electronic components in the enclosure	7
3.2.3 General	7
3.3 Installing the roof-mounted fan	8
3.3.1 Installation IP 21	8
3.3.2 Additional installation steps: Installation from outside IP 54/UL Type 12	9
3.3.3 Additional installation steps: Installation from inside IP 54/UL Type 12	10
3.3.4 Additional installation steps: Enhanced protection category IP 55/UL Type 12	10
3.3.5 Additional installation steps: Protection category IP 21/UL Type 1 and higher air throughput	11
4. Electrical connection	12
4.1 Connecting the power supply	12
4.1.1 Notes on electrical installation	12
4.1.2 Connection data	12
4.1.3 Overvoltage protection and supply line load	12
4.1.4 PE conductor connection	12
4.1.5 Installing the power supply	12
4.2 Installing the pilot wire	14
5. Commissioning	15
6. Inspection and maintenance	15
7. Storage and disposal	15
8. Technical specifications	16
9. Accessories	17
10. Warranty	19
11. Customer services addresses	19

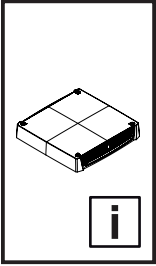

1. Safety instructions



1.1 Safety instructions

- Assembly, installation and servicing may only be performed by properly trained specialists.
- Do not obstruct the air inlet and air outlet of the roof-mounted fan inside and outside the enclosure.
- The specific air throughput of the roof-mounted fans must be adequate to meet the climate control requirements of the enclosure.
- Use only original spare parts and accessories.
- Do not make any changes to the roof-mounted fan other than those described in these and other applicable instructions.
- The roof-mounted fan must only be connected to the mains with the system de-energised. Connect the prefuse specified in the Technical Specifications.
- Never insert your fingers into the rotating fan blade.
- The roof-mounted fan must only be fitted on a sealed enclosure with protected access to the electrical connection.
- Electrical connection and any repairs may only be carried out by authorised, specialist personnel.
- Children and persons with limited cognitive/coordination abilities must not operate, maintain or clean the unit or be allowed to use it as a toy.
- Spending long periods in the airflow may irritate the eyes and muscles.
- If extinguisher gas is used in the enclosure, the roof-mounted fan must be incorporated into the fire protection concept.

1.2 Intended use

Rittal roof-mounted fans were developed and designed in accordance with the state of the art and the recognised rules governing technical safety. Nevertheless, if used improperly, they may pose a threat to life and limb or cause damage to property. The unit is only intended for ventilating enclosures and electronic cases. Any other use is deemed improper. The manufacturer will not be liable for any damages caused as a result of improper use, or for incorrect assembly, installation or use. All risk is borne solely by the user.

Proper usage also includes the observation of all valid documents and compliance with the inspection and servicing conditions.

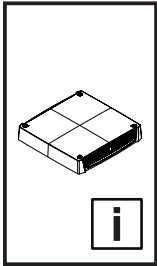

2. Product description

2.1 Components

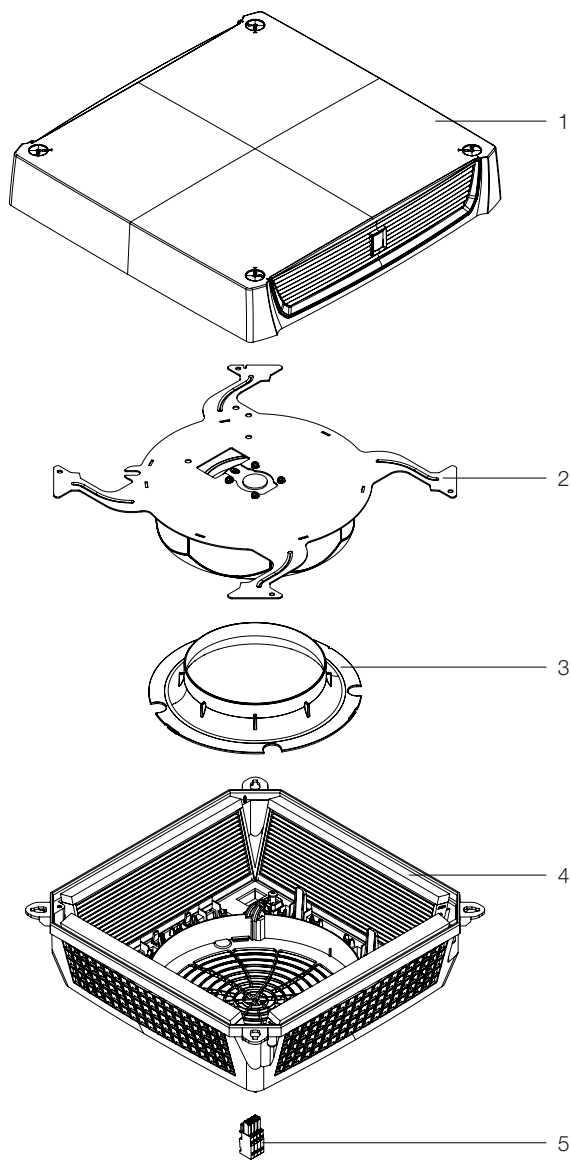

Key

- 1 Cover
- 2 Fan plate with fan
- 3 Inflow nozzle for air routing
- 4 Base tray with pleated filter
- 5 Electrical connector

Fig. 1: Components

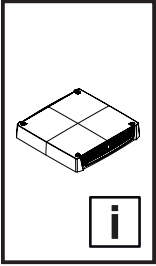

2. Product description

2.2 Scope of supply

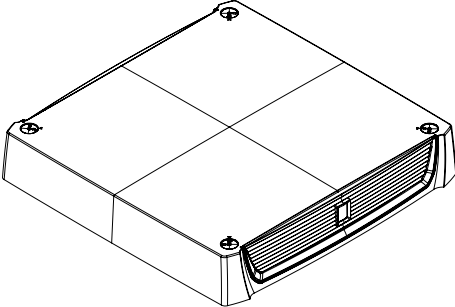
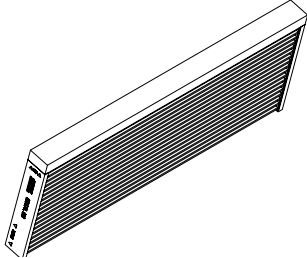
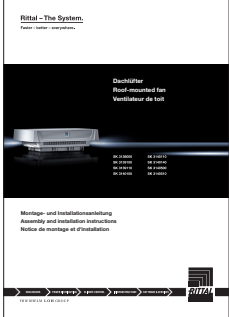
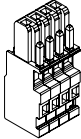
Description	Illustration	Qty.	Annotation
Roof-mounted fan		1x	
Pleated filter		4x	pre-installed
Assembly and installation instructions		1x	
Connector		1x	

Tab. 1: Scope of supply

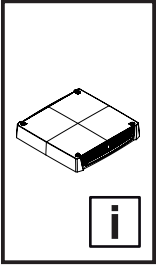

2. Product description

2.3 Function

2.3.1 General

The roof-mounted fan in conjunction with the corresponding inlet filter(s) is used to dissipate heat loss from enclosures and ventilate the enclosure, thereby protecting temperature-sensitive components.

This is achieved via the direct intake of ambient air, the temperature of which must be lower than the admissible enclosure interior temperature.

The ambient air enters the enclosure via an air inlet grille in the lower section and is drawn upwards through the enclosure by the roof-mounted fan. The warmed air is then returned to the outside via the fan. It is not possible to change the air flow direction.

2.3.2 Safety devices

The fan is equipped with a thermal winding protection for protection against overload.

2.3.3 Filter mats

The roof-mounted fan is supplied with four pleated filters (class ePM10 50% to ISO 16890) pre-installed. The filter must be checked regularly depending on the level of dust exposure, and replaced as necessary.

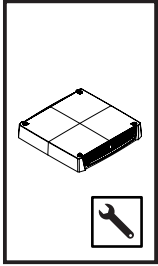

3. Mounting



3.1 Choosing the installation site

- When choosing the installation site for the enclosure, please observe the following:
 - The site for the enclosure, and hence the position of the roof-mounted fan, must be carefully selected so as to ensure good ventilation.
 - The site must be free from excessive dirt and moisture.
 - Roof-mounted fans must always be installed on horizontal panels (roof).
 - The ambient temperature must be lower than the admissible enclosure interior temperature.
 - The mains connection data as stated on the rating plate of the unit must be guaranteed.

3.2 Notes on installation

3.2.1 General

- Check the packaging carefully for signs of damage. Any packaging damage may be the cause of a subsequent functional failure.



Note:
The inlet filter must ensure an adequate air exchange.

- The enclosure must be sealed on all sides (IP 54). If the enclosure has a leak, unfiltered, contaminated air may enter the enclosure.
- The fan motor is a rotating component that may transfer vibrations and oscillations.
- Appropriate measures to decouple vibration must be taken in advance by the company responsible for the overall plant or system.
- During transportation, the roof-mounted fan must be secured in accordance with section 3.3.2 or section 3.3.3 to prevent damage.

3.2.2 Layout of the electronic components in the enclosure

- Take note of the air flows from the internal fans of installed electronic components.
- When installing the roof-mounted fan, it is important to ensure that the airflows of fans and built-in electronic components do not adversely influence one another (air short-circuit).
- The corresponding minimum distances between the fan and component must be observed in order to ensure unhindered air circulation.

3.2.3 General

- Carefully deburr the cut-out to prevent injuries caused by sharp edges.
 - The position of the roof-mounted fan in the mounting cut-out is freely selectable. It should be based on the position of the electrical connection inside the enclosure.
 - No filter mats are needed in order to achieve protection category IP 21.
- Check that the clips are completely snapped into place to ensure that the roof-mounted fan is securely held in the mounting cut-out.
 - The filter mats may be removed to achieve a higher air throughput. In this case, the protection category will be reduced to IP 21 and UL Type 1.
- Use only original Rittal filters which bear the Rittal logo to be sure of the protection category, air throughput and approvals.
 - The protection category of the roof-mounted fan can be raised to IP 55. To this end, the pleated filters must be replaced with Rittal filter mats SK 3174100. The side with the Rittal logo must face towards the fan (see section 3.3.4).
 - Note: This reduces the air throughput. For details, please refer to the performance diagrams which can be found on the Rittal website.
 - You should inspect the filter regularly depending on the amount of dust. Recommended: Replace after 2,000 operating hours at the latest, and as and when necessary.
 - The orientation of the cover on the base tray is freely selectable.

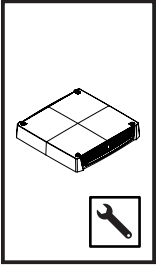

3. Mounting



3.3 Installing the roof-mounted fan

3.3.1 Installation IP 21

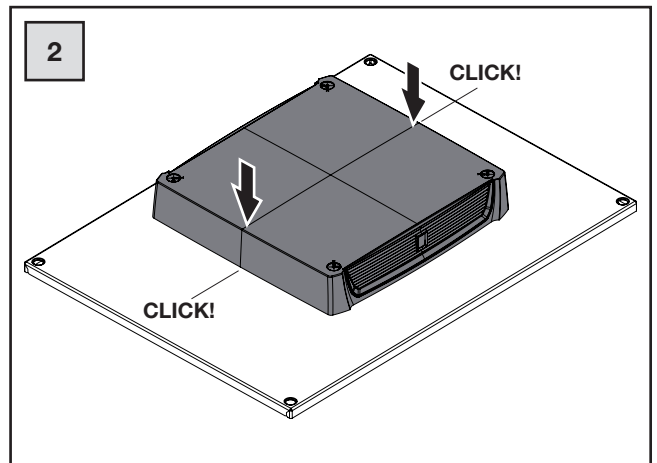
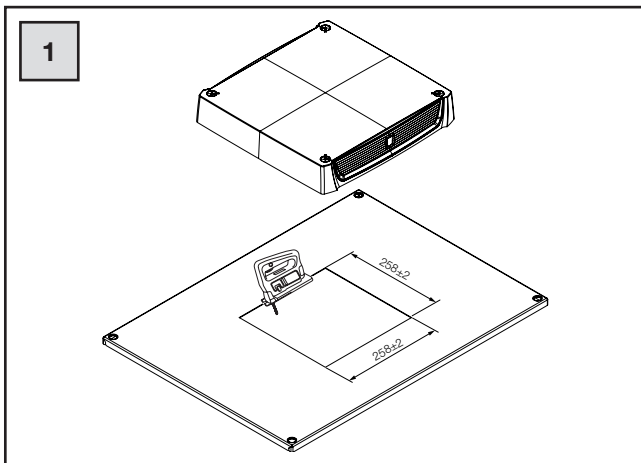

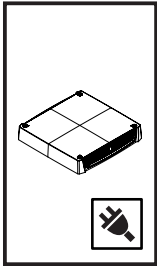

3. Mounting



3.3 Installing the roof-mounted fan

3.3.2 Additional installation steps: Installation from outside IP 54/UL Type 12

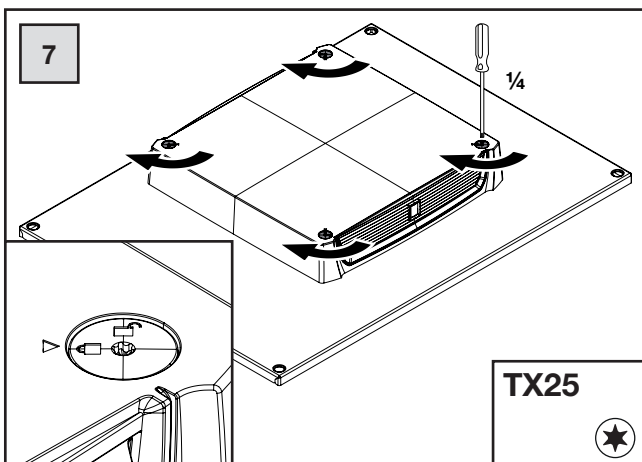
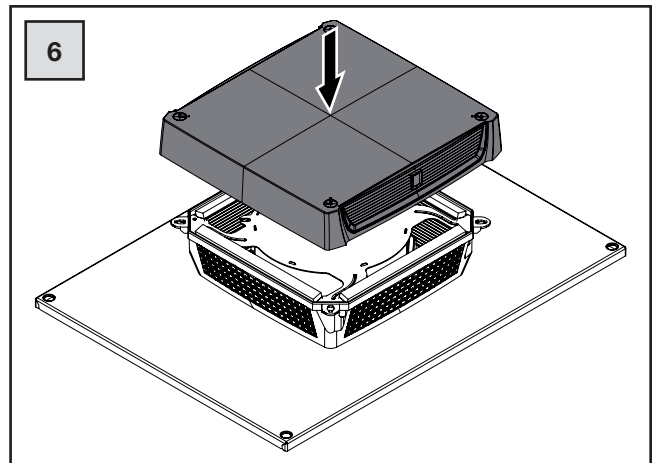
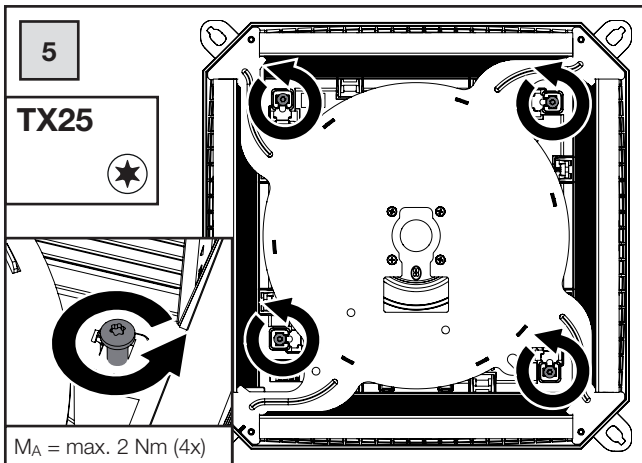
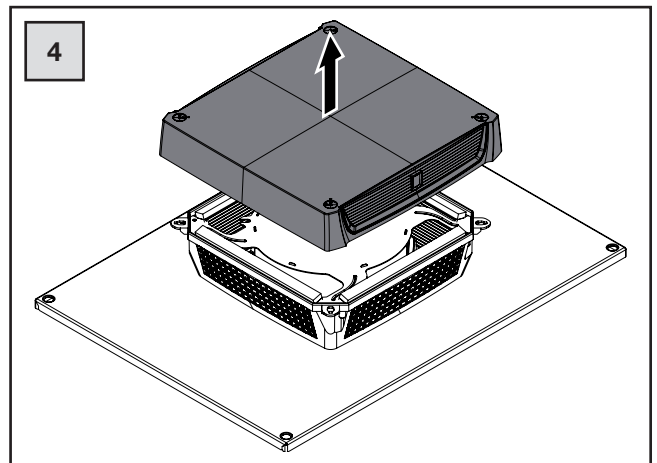
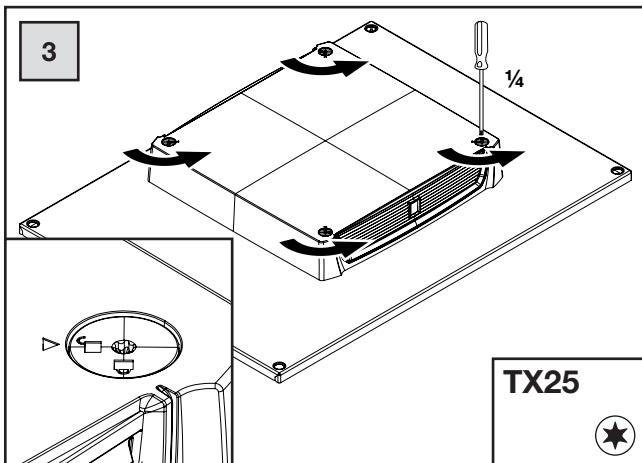

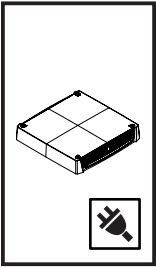

3. Mounting



3.3 Installing the roof-mounted fan

3.3.3 Additional installation steps: Installation from inside IP 54/UL Type 12

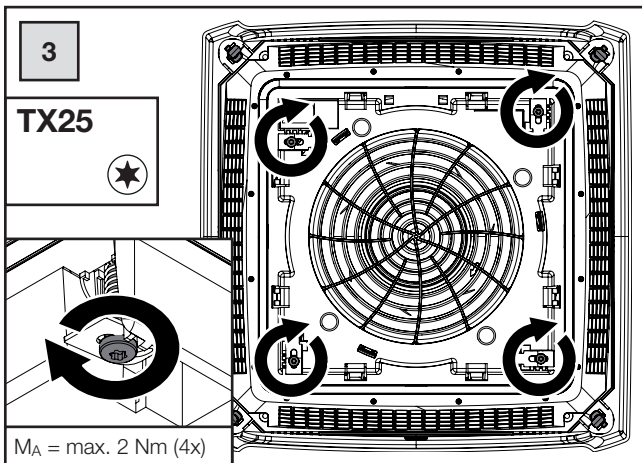

3.3.4 Additional installation steps: Enhanced protection category IP 55/UL Type 12

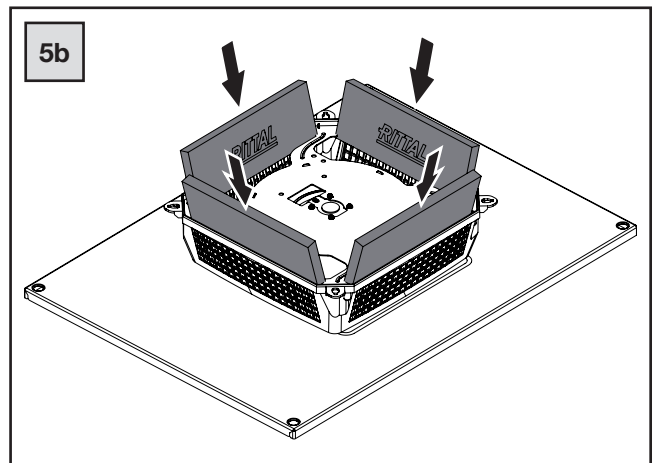
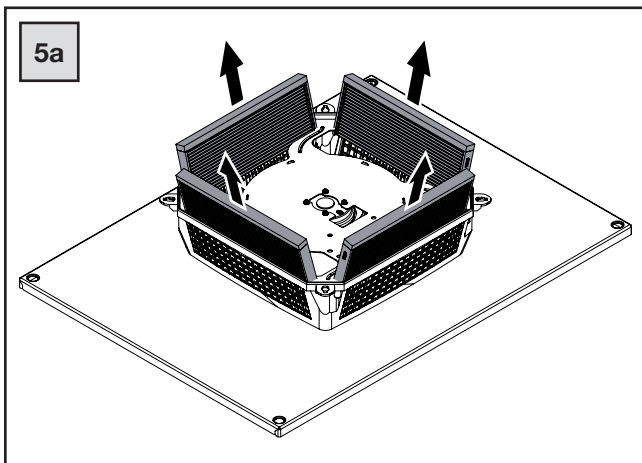

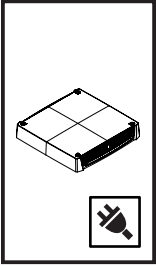

3. Mounting



3.3 Installing the roof-mounted fan

3.3.5 Additional installation steps: Protection category IP 21/UL Type 1 and higher air throughput

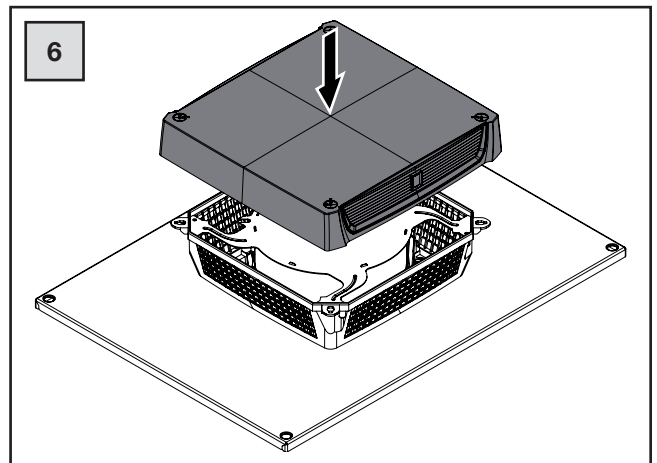
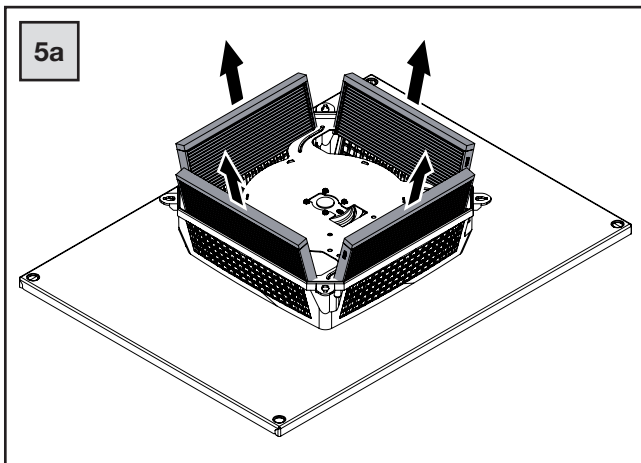

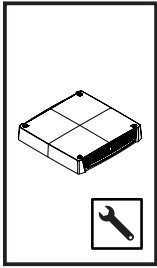

4. Electrical connection



4.1 Connecting the power supply

4.1.1 Notes on electrical installation

- When performing the electrical installation, it is important to observe all valid national and regional regulations as well as the provisions of the responsible electrical supply company.
- The electrical installation must only be carried out by a qualified electrician who is responsible for compliance with the existing standards and regulations.

4.1.2 Connection data

- The connected voltage and frequency must correspond to the values stated on the rating plate.
- The electrical installation and any repairs may only be carried out by authorised specialist personnel.
- Use only original spare parts!
- Install the pre-fuse cited in the Technical Specifications (circuit-breaker or slow fuse) to protect from short-circuits.
- If several fans are operated on a single pre-fuse, observe the total connected load.
- The roof-mounted fan must be connected to the mains via an all-pole disconnecting device to overvoltage category III (IEC 61058-1).

4.1.3 Overvoltage protection and supply line load

- The unit does not have its own overvoltage protection.
- Measures must be taken at the supply end by the switch-gear manufacturer or operator to ensure effective protection against lightning and overvoltage.
- The units are classified as overvoltage category III. The mains voltage must not exceed a tolerance of $\pm 10\%$.

4.1.4 PE conductor connection

- The PE conductor must be connected to the PE conductor system of the overall system.

4.1.5 Installing the power supply

- Remove the mains connector from the packaging and connect to the mains as shown in the connection diagram.
- The connection terminal supplied allows the connection of cable cross-sections of 0.5 to 4 mm².
- A smaller pilot wire (section 4.2) may be selected (min. 0.34 mm²).
- In accordance with NFPA 70 (NEC), only copper conductors must be used to connect the supply cable to the mains connector.
- If no wire end ferrules are used, strip the individual wires by max. 9 mm (observe the applicable clearances and creepage distances).
- Connect the connector to the roof-mounted fan from below.

Connection	Pin	Function/assignment
L		Power supply
N		Neutral conductor
PE		PE conductor
+10 V	1	Voltage output 10 V max. 1.1 A, galvanically isolated, not short circuit-protected
0...10 V/PWM	2	Control input 0...10 V or PWM, galvanically isolated, impedance 100 k Ω
GND	3	GND connection of the control interface
Speed	4	Speed output Open Collector, 1 pulse per revolution, galvanically isolated

Tab. 2: Connection designations

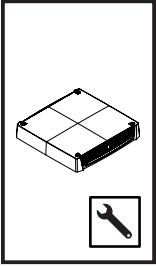

4. Electrical connection



4.1 Connecting the power supply

4.1.5 Installing the power supply

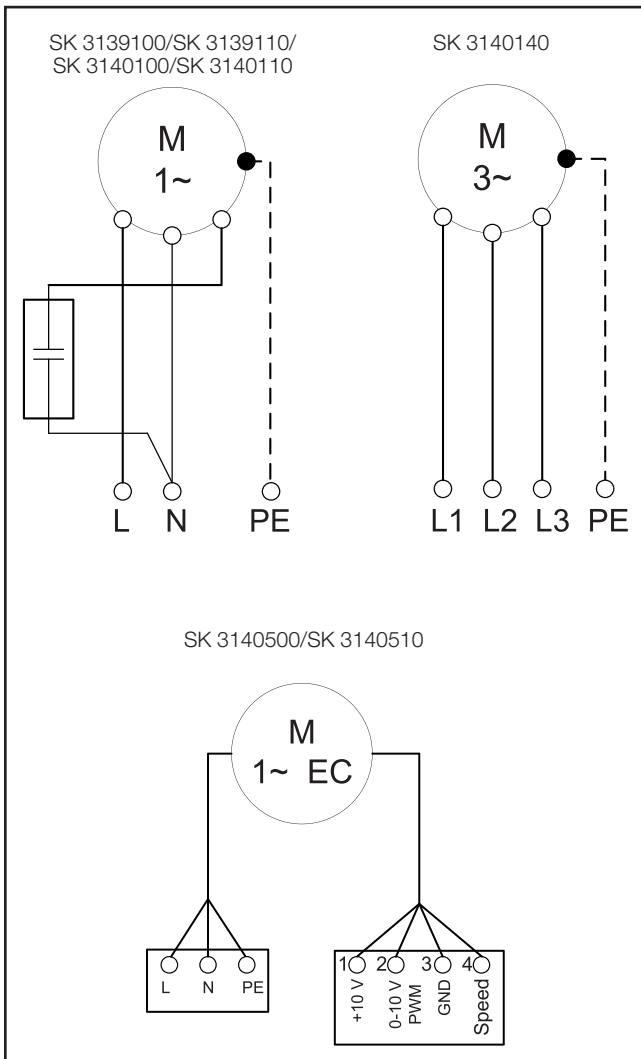

Fig. 2: Connection diagrams

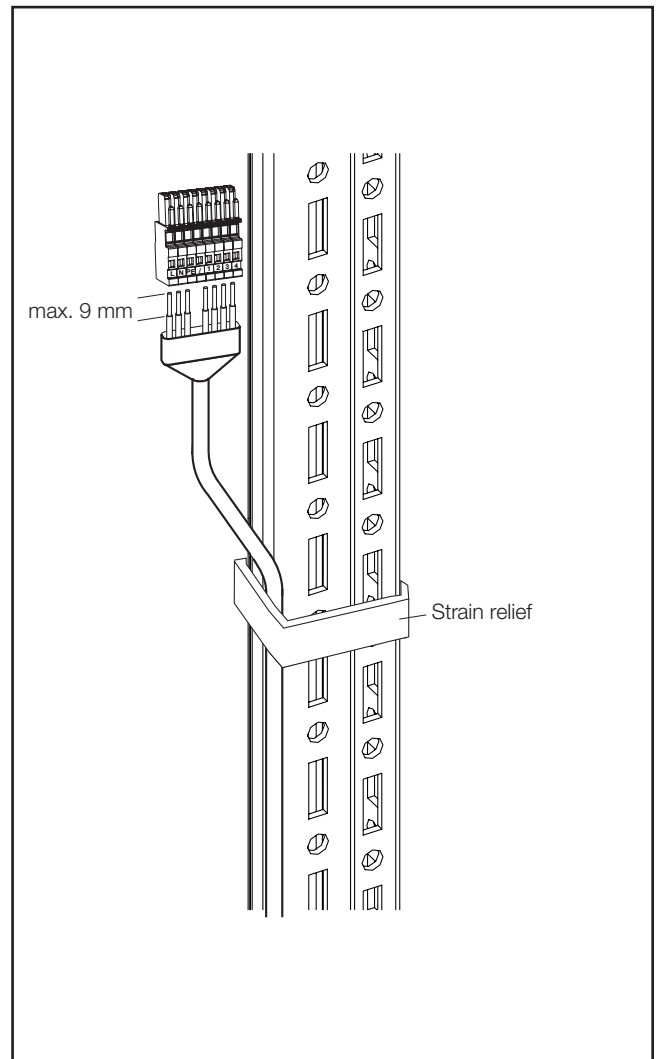
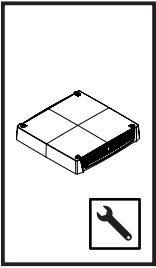

Fig. 3: Connector and strain relief



4. Electrical connection



4.2 Installing the pilot wire

- To control the EC roof-mounted fans via an external control unit (e.g. SK 3235440), types SK 31405xx have additional connections for the pilot wire.
- Release and remove the jumper between the "+10 V" and "0 – 10 V/PWM" (terminals 1 and 2) connections.
- Use a screwdriver with a 3.5 x 0.5 mm blade.
- Open the terminal with the screwdriver and insert the connection cable as shown in the connection diagram.
- Remove the screwdriver.
- To operate without a pilot wire, the jumper should be left in the connection terminal. The unit will then be operated at maximum speed.

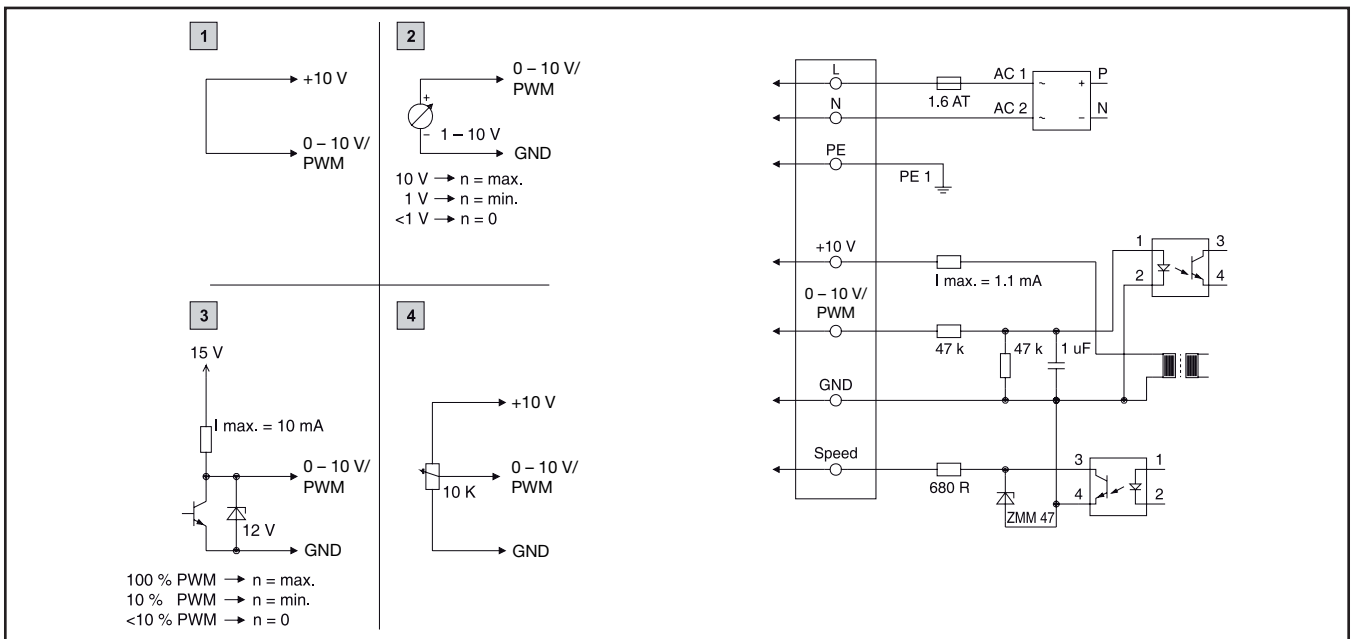
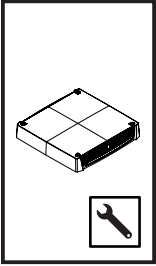

Fig. 4: Pilot wire

- 1 Max. speed (as delivered, with jumper between the "+10 V" and "0 – 10 V/PWM" connections).
- 2 Adjustable speed
- 3 Adjustable speed via PWM 1 – 10 kHz
- 4 Adjustable speed via potentiometer



5. Commissioning

- Once all the assembly and installation work is complete, switch on the power supply to the roof-mounted fan. The roof-mounted fan operates automatically, in other words, the fan will start up once the power has been switched on.
- EC roof-mounted fans start running with a delay of approx. 15 sec.

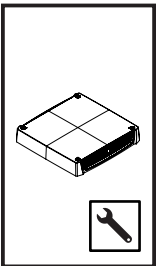

6. Inspection and maintenance

- Disconnect the electrical connection cable of the roof-mounted fan from the power supply.
 - The installed maintenance-free fan is mounted on ball bearings, protected against moisture and dust, and fitted with a temperature monitor.
 - The life expectancy is at least 50,000 operating hours (L10, 40 °C).
 - The roof-mounted fan is therefore largely maintenance-free.
 - From time to time, the components may need to be cleaned using a vacuum cleaner or compressed air if they become visibly dirty.
 - Any stubborn, oily stains may be removed using a nonflammable detergent, such as degreaser.
- Never use flammable liquids for cleaning the unit.

Sequence of maintenance work

- Check the level of dirt: If necessary, vacuum the fan housing, or clean with compressed air.
- Filter soiling: Replace the filter.
- Check the noise generation of the fan.

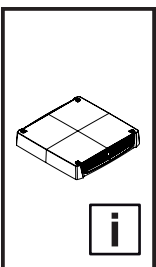

7. Storage and disposal

The roof-mounted fan must be stored at a temperature within the range specified in the technical data.

Disposal can be entrusted to the Rittal factory. Please call for further information.

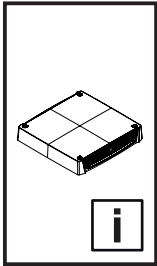

8. Technical specifications

Technical specifications	Unit	SK 3138000	SK 3139100	SK 3139110	SK 3140100	SK 3140110	SK 3140140	SK 3140500	SK 3140510	
Electrical specifications										
Rated operating voltage	V Hz	without fan motor	220...240, 1~, 50/60	115, 1~, 60	220...240, 1~, 50/60	115, 1~, 60	380...415, 3~, 50/60 400...480, 3~, 60	220...240, 1~, 50/60	115, 1~, 60	
Tolerance rated operating voltage		–	±10 %							
Rated current max.	A	–	0.23/0.27	0.56	0.43/0.56	1.2	0.17/0.2	1	1.51	
Power consumption	W	–	51/62	65	99/130	138	90/120 98/130	129	112	
Pre-fuse	A	–	3				–	3		
Motor circuit-breaker		–	–				0.2...0.4	–		
Rated insulation voltage (Ui)	V	–	300							
Rated impulse withstand voltage (Uimp)	kV	–	4					2		
Control interface		–	–						included	
Weight										
Weight (net)	kg	3.2	5.2		6.0			5.6		
Air throughput (for performance diagrams, see Rittal homepage)										
Air throughput, unimpeded air flow (without filter mats)	m³/h	–	500/525	525	873/965	965	863/942	1069	1069	
Air throughput, unimpeded air flow (with pleated filter IP 54)	m³/h	–	475/515	515	810/868	868	800/853	975	975	
Air throughput, unimpeded air flow (with chopped-fibre filter IP 55)	m³/h	–	417/446	446	725/759	759	700/749	841	841	
Air throughput (with filter mats and inlet filter)										
1 x SK 3243200 with chopped-fibre filter	m³/h	–	360/383	383	557/572	572	550/565	690	690	
1 x SK 3243200 with pleated filter	m³/h	–	425/460	460	698/730	730	690/720	847	847	
Fan		–	Radial/capacitor motor				Radial/rotary current motor	Radial/EC motor		
Electromagnetic compatibility										
Immunity to interference		–	For industrial areas to EN 61000-6-2							
Emitted interference		–	For residential, business and commercial areas and small companies to EN 61000-6-3							
Other										
Noise level (with filter mats)	dB (A)	–	52/54	54	58/60	60	56/58	60	60	
Noise level (without filter mats)	dB (A)	–	54/56	56	60/62	62	60/61	63	63	
Operating temperature range	°C	-20...+55								
Storage temperature range	°C	-40...+70								
Degree of protection (according to IEC 60529)		IP 21 (without filter and installation in accordance with section 3.3.1 or 3.3.5) IP 54 (with pleated filter and installation in accordance with section 3.3.2 or 3.3.3) IP 55 (with chopped-fibre filter and installation in accordance with section 3.3.4)								
Degree of protection (NEMA)		Type 1 (without filter and installation in accordance with section 3.3.2, 3.3.3 or 3.3.5) Type 12 (with pleated or chopped-fibre filter and installation in accordance with section 3.3.2 or 3.3.3)								

Tab. 3: Technical specifications

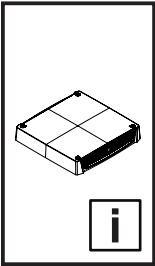

8. Technical specifications

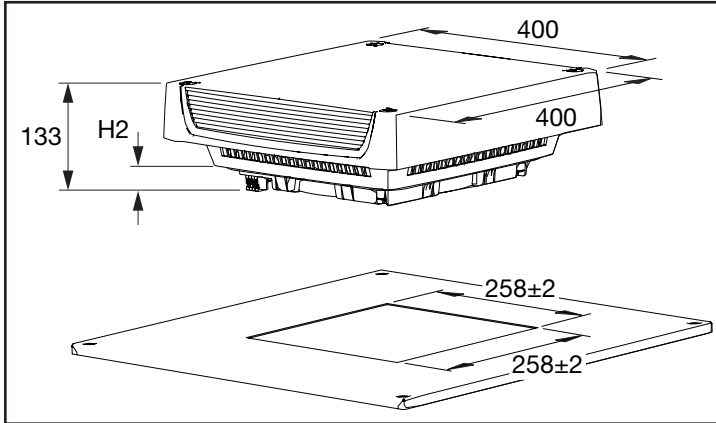

H2 = 27.5 mm for SK 3138000

H2 = 34.6 mm for SK 3139100, SK 3139110, SK 3140100, SK 3140110, SK 3140140, SK 3140500, SK 3140510

Fig. 5: Dimensions

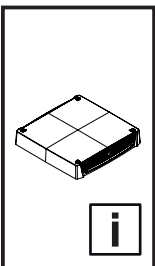

9. Accessories

Pleated filter

To fit Model No.	Filter class in accordance with		Packs of	Model No.
	DIN EN 779	ISO 16890		
SK 3138000, SK 3139100, SK 3139110, SK 3140100, SK 3140110, SK 3140140, SK 3140500, SK 3140510	M5	ePM10 50 %	12 pc(s).	SK 3174120

Tab. 4: Pleated filter

Chopped-fibre filter

To fit Model No.	Filter class in accordance with		Packs of	Model No.
	DIN EN 779	ISO 16890		
SK 3138000, SK 3139100, SK 3139110, SK 3140100, SK 3140110, SK 3140140, SK 3140500, SK 3140510	G3	ISO coarse 50 %	12 pc(s).	SK 3174100

Tab. 5: Chopped-fibre filter

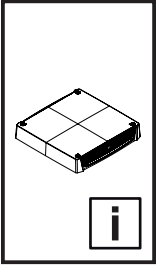

9. Accessories

Enclosure internal thermostat

To fit Model No.	Packs of	Model No.
SK 3139100, SK 3139110, SK 3140100, SK 3140110, SK 3140140, SK 3140500, SK 3140510	1 pc(s).	SK 3110000

Tab. 6: Enclosure internal thermostat

Digital enclosure internal temperature display and thermostat

To fit Model No.	Packs of	Model No.
SK 3139100, SK 3139110, SK 3140100, SK 3140110, SK 3140140, SK 3140500, SK 3140510	1 pc(s).	SK 3114200

Tab. 7: Digital enclosure internal temperature display and thermostat

Hygrostat

To fit Model No.	Packs of	Model No.
SK 3139100, SK 3139110, SK 3140100, SK 3140110, SK 3140140, SK 3140500, SK 3140510	1 pc(s).	SK 3118000

Tab. 8: Hygrostat

Speed control

To fit Model No.	Packs of	Model No.
SK 3139100, SK 3139110, SK 3140100, SK 3140110	1 pc(s).	SK 3120200

Tab. 9: Speed control

Sensor for speed control

To fit Model No.	Packs of	Model No.
SK 3140500, SK 3140510	1 pc(s).	SK 3235450

Tab. 10: Sensor for speed control

Control unit for speed control

To fit Model No.	Packs of	Model No.
SK 3140500, SK 3140510	1 pc(s).	SK 3235440

Tab. 11: Control unit for speed control

Outlet filter

To fit Model No.	Packs of	Model No.
SK 3138000, SK 3139100, SK 3139110, SK 3140100, SK 3140110, SK 3140140, SK 3140500, SK 3140510	1 pc(s).	SK 3243200

Tab. 12: Outlet filter

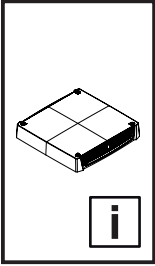

10. Warranty

The conditions named in the sales and delivery conditions of the associated Rittal agents and subsidiaries apply.

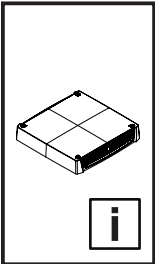

11. Customer services addresses

Headquarters Germany

RITTAL GmbH & Co. KG
 Auf dem Stuetzelberg
 35745 Herborn
 Germany
 Phone +49(0)2772 505-1855
 Fax +49(0)2772 505-1850
 E-mail: service@rittal.de

Service HUB USA

RITTAL North America LLC
 801 State Route 55 Dock 25
 Urbana, OH 43078
 Phone: +1 800 477 4000, option 3
 E-mail: rittal@rittal.us

Service HUB China

RITTAL Electro-Mechanical Technology Co. Ltd.
 No. 1658, Minyi Road
 Songjiang District
 Shanghai, 201612
 Phone +86 21 5115 7799-213
 Fax +86 21 5115 7788
 E-mail: service@rittal.cn

Service HUB India

RITTAL India Pvt. Ltd.
 Nos. 23 & 24, KIADB
 Industrial Area Veerapura
 Doddaballapur-561 203
 Bengaluru District
 Phone +91 (80) 22890792
 Fax +91 (80) 7623 343
 E-mail: service@rittal-india.com

EU-Konformitätserklärung / EU Declaration of Conformity



Dri171781400

Wir, / We,

Rittal GmbH & Co. KG • Auf dem Stützelberg • 35745 Herborn

Erklären, dass die Produkte / declare that the products

Dachlüfter Roof Mounted Fan

SK 3138.000 SK 3139.100 SK 3139.110 SK 3140.100 SK 3140.110 SK 3140.140
SK 3140.500 SK 3140.510

folgenden Richtlinien entsprechen: / conform to the following Directives

Maschinenrichtlinie 2006/42/EG - Machinery Directive 2006/42/EC
EMV-Richtlinie 2014/30/EU – EMC Directive 2014/30/EU

Angewandte harmonisierte Normen: / Applied harmonised standards

EN ISO 12100

Sicherheit von Maschinen – Allgemeine Gestaltungsleitsätze – Risikobeurteilung und Risikominderung
Safety of machinery – General principles for design – Risk assessment and risk reduction

EN 60335-1

Sicherheit elektrischer Geräte für den Hausgebrauch und ähnliche Zwecke – Teil 1: Allgemeine Anforderungen
Household and similar electrical appliances – Safety – Part 1: General requirements

EN 60529

Schutzarten durch Gehäuse (IP-Code)
Degrees of protection provided by enclosures (IP code)

EN 61000-6-2:2005

Elektromagnetische Verträglichkeit (EMV) – Teil 6-2: Fachgrundnormen; Störfestigkeit
Electromagnetic compatibility (EMC) – Part 6-2: Generic standards; Immunity ...

EN 61000-6-3:2007, A1:2011

Elektromagnetische Verträglichkeit (EMV) – Teil 6-3: Fachgrundnormen; Störaussendung....
Electromagnetic compatibility (EMC) – Part 6-3: Generic standards; Emission ...

EN 61000-3-2:2014

Elektromagnetische Verträglichkeit (EMV) - Teil 3-2: Grenzwerte - Grenzwerte für Oberschwingungsströme
Electromagnetic compatibility (EMC) - Part 3-2: Limits - Limits for harmonic current emissions

EN 61000-3-3:2013

Elektromagnetische Verträglichkeit (EMV) - Teil 3-3: Grenzwerte - Begrenzung von Spannungsänderungen...
Electromagnetic compatibility (EMC) - Part 3-3: Limits - Limitation of voltage changes

Verantwortlich für Dokumentation
responsible for documentation

Rittal GmbH & Co. KG
Auf dem Stützelberg
35745 Herborn

Herborn, *01.05.19*

F. Himmelhuber
Frank Himmelhuber, Geschäftsbereichsleiter FuE
Executive Vice President R&D

Bei einer nicht mit uns abgestimmten Änderung des Produkts verliert diese EU-Konformitätserklärung ihre Gültigkeit.
In case of any amendments to the assembly not explicitly agreed with us, this EU Declaration of Conformity shall be invalidated.

Id. Nr. 335612
Dok. Nr. D-0000-00000434.

SCHALTSCHRÄNKE STROMVERTEILUNG KLIMATISIERUNG IT-INFRASTRUKTUR SOFTWARE & SERVICE

FRIEDHELM LOH GROUP

Seite 1 von 1

Notes

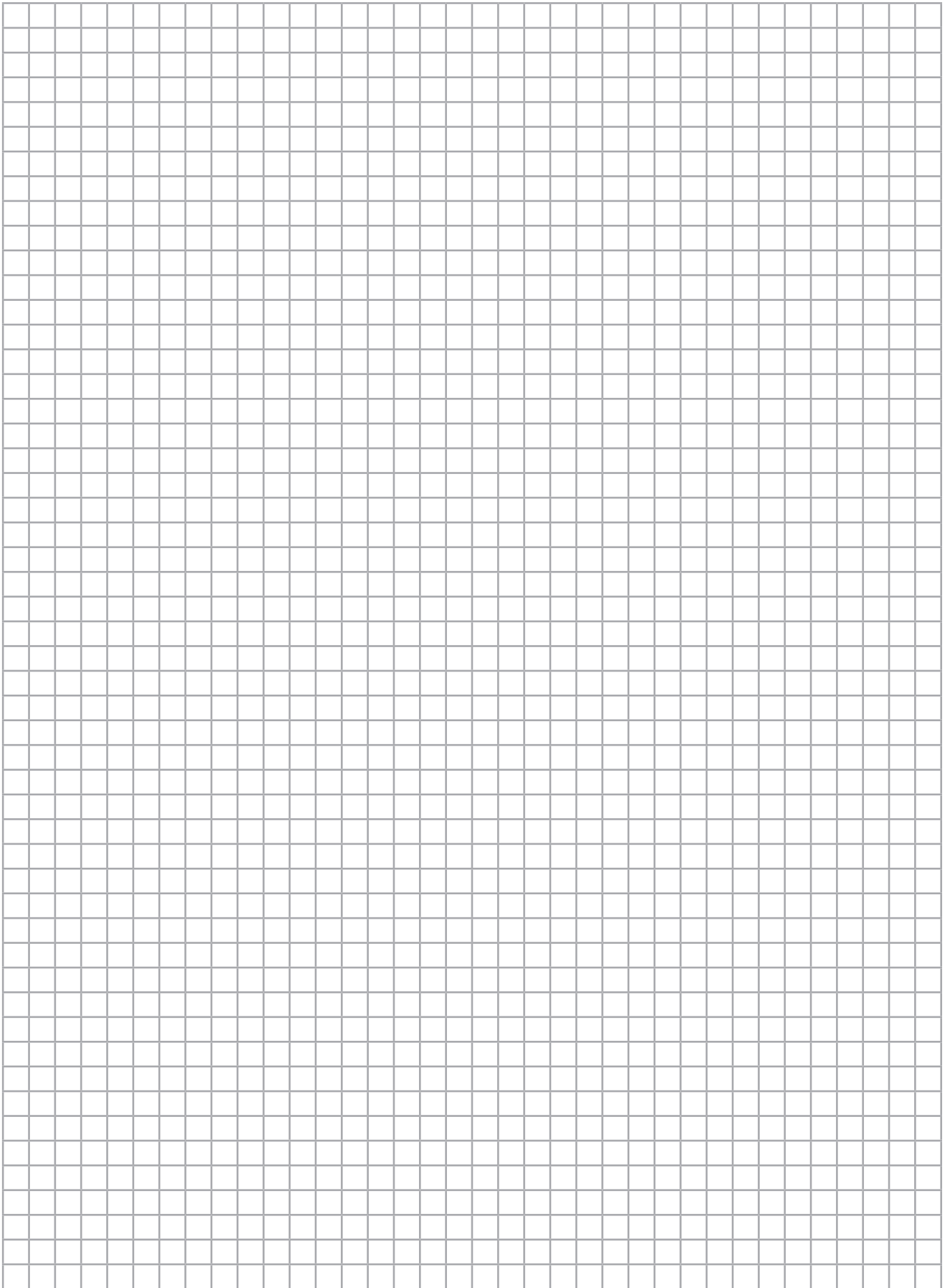

Rittal – The System.

Faster – better – everywhere.

- Enclosures
- Power Distribution
- Climate Control
- IT Infrastructure
- Software & Services

You can find the contact details of all Rittal companies throughout the world here.



www.rittal.com/contact

RITTAL GmbH & Co. KG
Auf dem Stuetzelberg · 35745 Herborn · Germany
Phone +49 2772 505-0
E-mail: info@rittal.de · www.rittal.com

03.2022/D-0000-00000432-04-EN

ENCLOSURES

POWER DISTRIBUTION

CLIMATE CONTROL

IT INFRASTRUCTURE

SOFTWARE & SERVICES

FRIEDHELM LOH GROUP

