

APPLICATIONS: EIA rack-mounted chassis, data processing, tele-communications and video racks, medical applications and electro/mechanical devices. **This product is covered by U.S. and various foreign patents issued and/or pending.**

Low Profile, Over Travel
Medium Duty, Non-Disconnect
Up to 175 lb.** [80kg.] Capacity

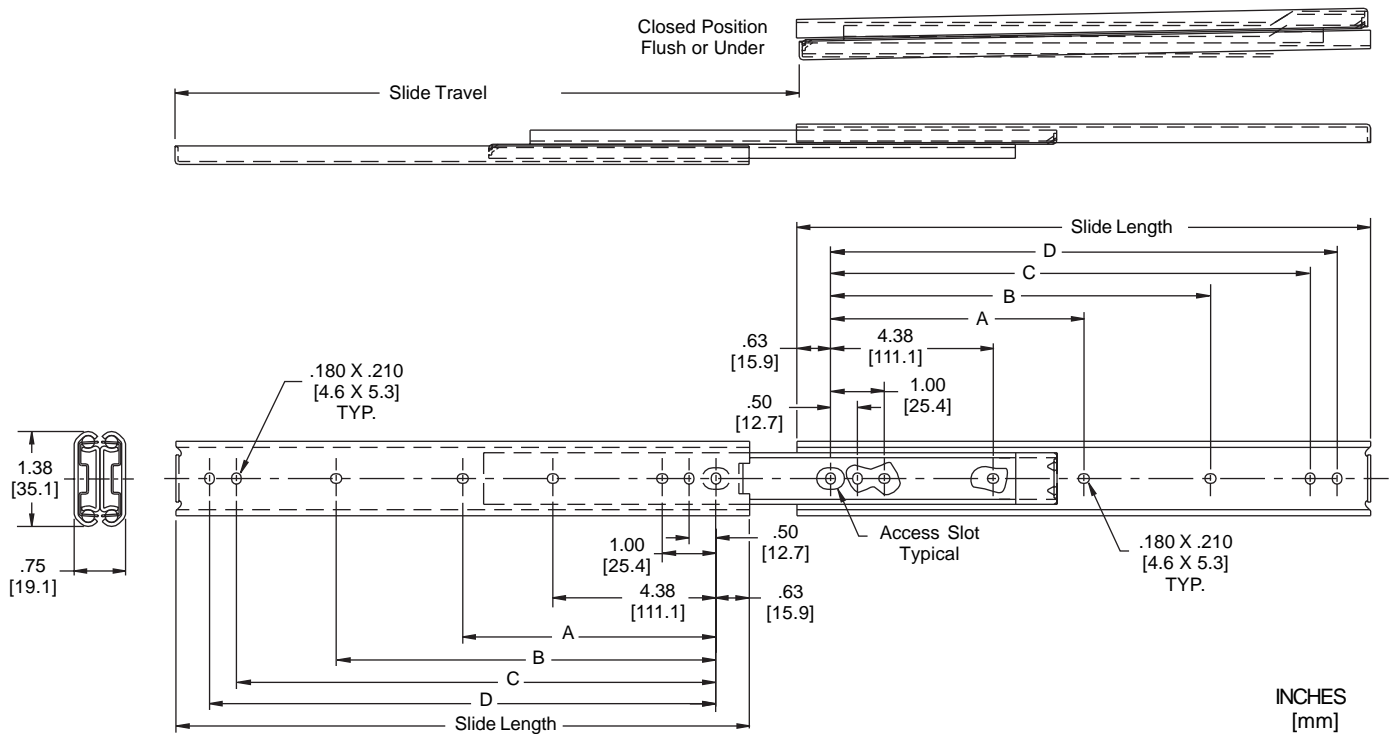

Finish Bright electro-zinc plating (C) or black zinc* (CB) finish available

Load 175 lbs.** [80kg] per pair

Length 12" - 28" [305mm - 711mm]

Sidespace .75" +.030 / -.000
[19.1mm +.76 / -.00]

Travel Slide length + .88" [22mm]

Mounting Side, bracket or hard mounting

Height 1.38" [35.1]

Movement Steel ball bearings

Hardware #8 pan head screw

* Minimum order quantities may apply.

** Load rating based on a 16" wide drawer cycled 10,000 times.

Part Number	Slide Length	Slide Travel	Load Rating lbs [kg]	A	B	C	D
301-12	12.00 [305]	12.88 [327]	175 [80]		5.88 [149.4]	10.25 [260.4]	10.75 [273.1]
301-14	14.00 [356]	14.88 [378]	170 [77]		7.88 [200.2]	12.25 [311.2]	12.75 [323.9]
301-16	16.00 [406]	16.88 [429]	160 [73]		9.88 [251.0]	14.25 [362.0]	14.75 [374.7]
301-18	18.00 [457]	18.88 [480]	150 [68]	8.38 [212.9]	11.88 [301.8]	16.25 [412.8]	16.75 [425.5]
301-20	20.00 [508]	20.88 [530]	142 [65]	9.38 [238.3]	13.88 [352.6]	18.25 [463.6]	18.75 [476.3]
301-22	22.00 [559]	22.88 [581]	130 [59]	10.38 [263.7]	15.88 [403.4]	20.25 [514.4]	20.75 [527.1]
301-24	24.00 [610]	24.88 [632]	115 [52]	11.38 [289.1]	17.88 [454.2]	22.25 [565.2]	22.75 [577.9]
301-26	26.00 [660]	26.88 [683]	105 [48]	12.38 [314.5]	19.88 [505.0]	24.25 [616.0]	24.75 [628.7]
301-28	28.00 [711]	28.88 [734]	90 [41]	13.38 [340.0]	21.88 [555.8]	26.25 [666.8]	26.75 [679.5]

Installation Instructions

Instructions to Bracket Mount

- To ensure proper operation of the slides, make certain that all bracket mounting screws are inserted so that the screw heads are inside the slides. (No washers on the inside of the slides.)
- Using mounting kits and brackets, mount brackets to slide cabinet members (largest). For adjustment purposes screw the back brackets on loosely.
- Install slides into EIA rack with #10-32 screws (customer supplied) and secure with bar nuts. Rear adjustment is possible by aligning the back bracket. Do not tighten screws until final adjustment is made.
- Mount slide drawer members (smallest) to the chassis. Position slides 1/8" from the front edge of the chassis making sure both slides are parallel.
- It may be necessary to use a hoist for positioning and aligning the chassis when the weight exceeds 50 lbs. Check slide alignment by opening and closing the chassis. Any sign of binding indicates lateral stress or misalignment.
- Adjust slide position until movement is smooth. Tighten all screws and if necessary use more screws to secure slides and complete installation.

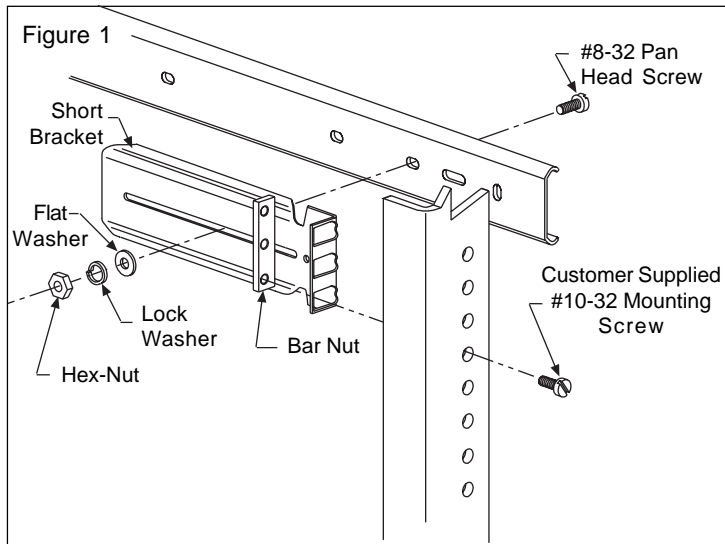

Instructions to Hard Mount

- Follow step 1 of "Bracket Mount" instructions.
- With slides fully extended, install cabinet members using # 8 pan head screws through uncovered mounting slots. Move intermediate members to allow access to remaining slots. Be sure slides are parallel.
- Mount chassis members. Access covered mounting screw holes by moving the intermediate members away from you. Leave all screws loose for future adjustment. Be sure slides are parallel.
- Follow steps 5 & 6 of "Bracket Mount" instructions.

Slide Ordering Instructions

Complete your slide order for model 301 by specifying the following information:

	10 Pair	C	301	-18	D
Total Slides Required	_____	_____	_____	_____	_____
Slide Finish	_____	_____	_____	_____	_____
Slide Model	_____	_____	_____	_____	_____
Slide Length	_____	_____	_____	_____	_____
Optional Polybag Packaging (includes mounting screws)	_____	_____	_____	_____	_____

Optional Hardware Kits - Ordered Separately

Kit contains 4 each short mounting brackets and mounting hardware. Order 1 kit per pair of slides.

	10 Each	4180-0222-XE
Total Bracket Kits Required	_____	_____
Optional Bracket Kit Part Number	_____	_____

Bracket kit includes the following. See Figure 1.

- | | |
|-------------------------|--------------------------|
| 4 short brackets | Part number 4000-0180-CE |
| 1 bracket hardware kit^ | Part number 4180-0230-XE |
- (^Kit contains screws, hex-nuts, washers, and bar nuts)

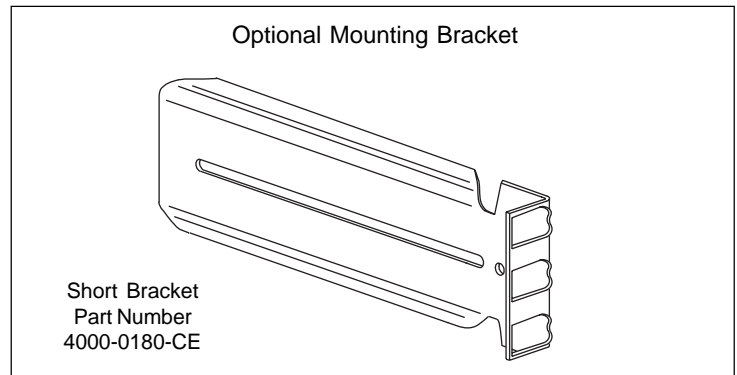

Packaging

Distributor (D) Pack: All lengths are packaged 5 pair per box. Polybag includes one pair of slides packaged with slide mounting screws and installation instructions.

Bulk (P) Pack: Lengths 12" - 18" 25 each per box
Lengths 20" - 28" 10 each per box

Optional bracket mounting kit (part number 4180-0222-XE) is ordered separately. Order 1 kit per pair of slides.

Specifications

Slide members: Cold rolled steel
Ball retainers: Cold rolled steel
Ball bearings: Carburized steel

NOTE: Specifications, materials, prices, terms, and delivery are subject to change without notice.

Accuride