

THIS DOCUMENT IS THE PROPERTY OF KEYSTONE ELECTRONICS CORP. AND SHALL NOT BE REPRODUCED, DISTRIBUTED OR USED AS A BASIS FOR MANUFACTURE WITHOUT PRIOR WRITTEN PERMISSION FROM KEYSTONE ELECTRONICS CORP.

ACTUAL SIZE

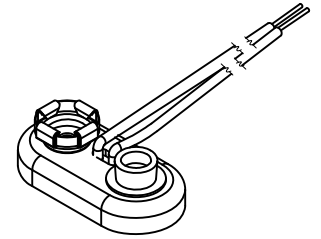
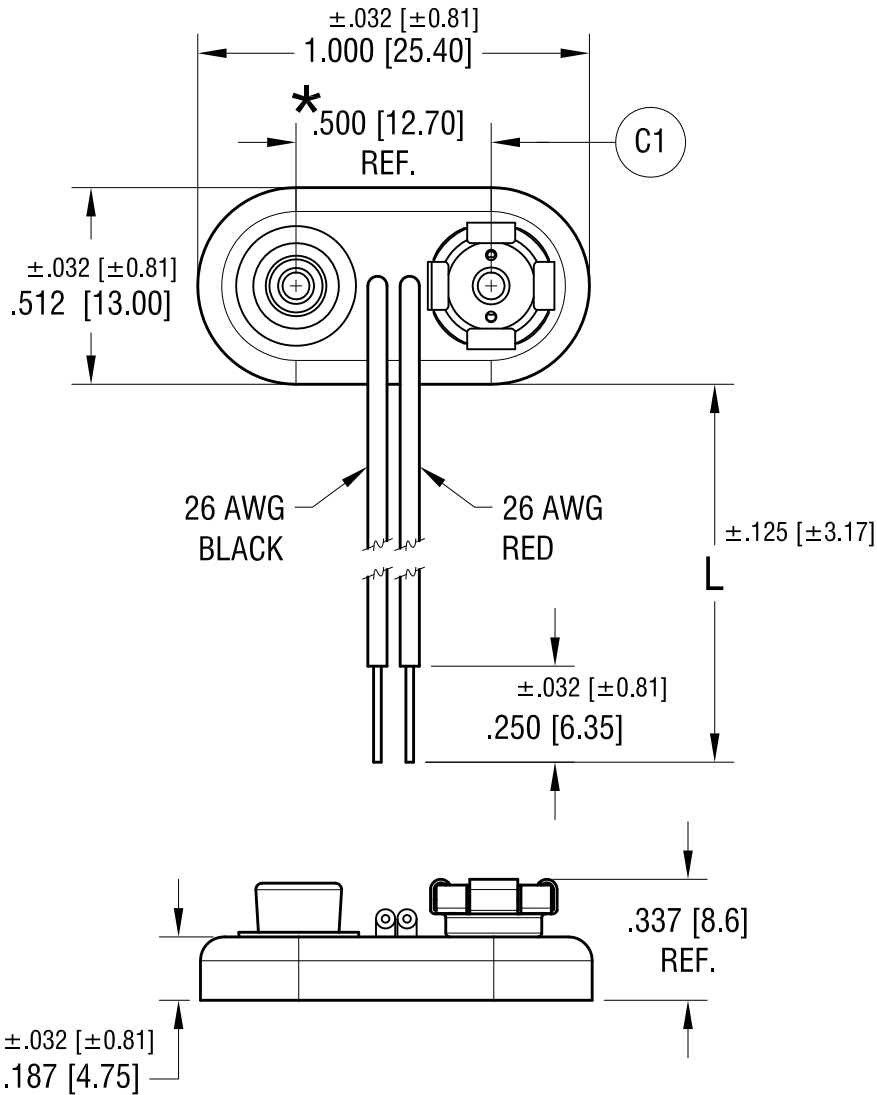

NOTE:

1. MAT'L - WIRE: 26 AWG, 1007 UL/CSA APPROVED
2. CONTACTS: PHOSPHOR BRONZE, NICKEL PLATE
3. BODY: MOLDED POLYETHYLENE
4. RED WIRE CONNECTED TO FEMALE CONTACT; BLACK WIRE CONNECTED TO MALE CONTACT.
5. * REF. DIMENSION MUST FIT INDUSTRY STANDARD 9 VOLT BATTERY.

PART NO.	'L' DIM.
2241	4.000 [101.60]
2242	6.000 [152.40]
2243	8.000 [203.20]

DATE	DESCRIPTION	REV.
8.23.21	ALL OUTSIDE HAD $\pm .020$ TOLERANCE C1 WAS $.512 + .015 / - .005$, ADD NOT 5. CHANGE AS PER ECN 21-096	C
6.1.05	CHANGE AS PER ECN 05-029	B
3.10.05	CHANGE AS PER ECN 05-017	A

KEYSTONE ELECTRONICS CORP.
 www.keyelco.com • NEW HYDE PARK, NY 11040 • Tel (516) 328-7500

PART NAME: PREMIUM '9' VOLT 'T' STYLE BATTERY STRAP

MATERIAL: AS NOTED

FINISH: AS NOTED

DRN BY: BOONE DATE: 8.08.85

APP'D: LN SCALE: 2X

TOLERANCES INCH [MM]
 DECIMAL $\pm .020 [±0.50]$
 ANGULAR $\pm 1^\circ$
 UNLESS OTHERWISE SPECIFIED

CODE: C

DWG NO.: 2241-2243

Mouser Electronics

Authorized Distributor

Click to View Pricing, Inventory, Delivery & Lifecycle Information:

[Keystone Electronics:](#)

[2242](#)