

±0.25°C Typ. Accuracy Digital Temperature Sensor

Features

- Accuracy:
 - ±0.25°C (typical) from -40°C to +125°C
 - ±1°C (maximum) from -40°C to +125°C
- User Selectable Measurement Resolution:
 - 0.5°C, 0.25°C, 0.125°C, 0.0625°C
- User Programmable Temperature Limits:
 - Temperature Window Limit
 - Critical Temperature Limit
- User Programmable Temperature Alert Output
- Operating Voltage Range: 2.7V to 5.5V
- Operating Current: 200 µA (typical)
- Shutdown Current: 0.1 µA (typical)
- 2-wire Interface: I²C/SMBus Compatible
- Available Packages: 2x3 DFN-8, MSOP-8

Typical Applications

- General Purpose
- Industrial Applications
- Industrial Freezers and Refrigerations
- Food Processing
- Personal Computers and Servers
- PC Peripherals
- Consumer Electronics
- Hand-held/Portable Devices

Temperature Accuracy

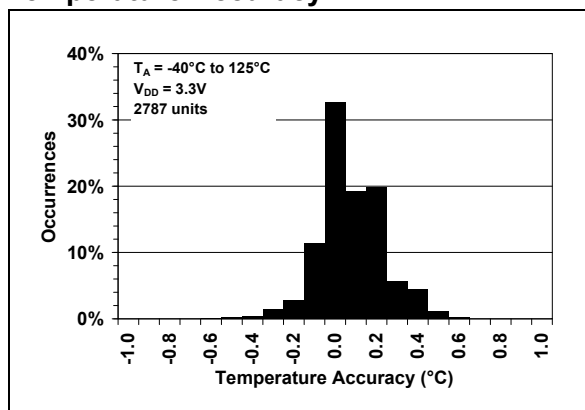

Description

Microchip Technology Inc.'s MCP9804 digital temperature sensor converts temperatures between -40°C and +125°C to a digital word with ±0.25°C/±1°C (typical/maximum) accuracy.

The MCP9804 comes with user-programmable registers that provide flexibility temperature sensing applications. The registers allow user-selectable settings such as Shutdown or low-power modes and the specification of temperature Alert window limits and Critical output limits. When the temperature changes beyond the specified boundary limits, the MCP9804 outputs an Alert signal. The user has the option of setting the Alert output signal polarity as an active-low or active-high comparator output for thermostat operation, or as temperature Alert interrupt output for microprocessor-based systems. The Alert output can also be configured as a Critical temperature output only.

This sensor has an industry standard 100 kHz 2-wire, SMBus/I²C compatible serial interface, allowing up to eight or sixteen sensors to be controlled with a single serial bus (see [Table 3-2](#) for available Address codes). These features make the MCP9804 ideal for sophisticated multi-zone temperature-monitoring applications.

Package Types

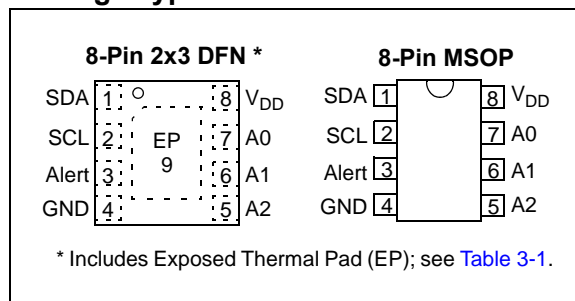

MCP9804

NOTES:

1.0 ELECTRICAL CHARACTERISTICS

Absolute Maximum Ratings †

V _{DD}	6.0V
Voltage at All Input/Output Pins	GND – 0.3V to 6.0V
Storage Temperature	-65°C to +150°C
Ambient Temperature with Power Applied	-40°C to +125°C
Junction Temperature (T _J)	+150°C
ESD Protection on All Pins (HBM:MM)	(4 kV:400V)
Latch-Up Current at Each Pin (25°C).....	±200 mA

†**Notice:** Stresses above those listed under “Maximum ratings” may cause permanent damage to the device. This is a stress rating only and functional operation of the device at those or any other conditions above those indicated in the operational listings of this specification is not implied. Exposure to maximum rating conditions for extended periods may affect device reliability.

TEMPERATURE SENSOR DC CHARACTERISTICS

Electrical Specifications: Unless otherwise indicated, V _{DD} = 2.7V to 5.5V, GND = Ground, and T _A = -40°C to +125°C.						
Parameters	Sym	Min	Typ	Max	Unit	Conditions
Temperature Sensor Accuracy						
+40°C < T _A ≤ +125°C	T _{ACY}	-1.0	±0.25	+1.0	°C	V _{DD} = 3.3V
Temperature Conversion Time						
0.5°C/bit	t _{CONV}	—	30		ms	33s/sec (typical)
0.25°C/bit		—	65		ms	15s/sec (typical)
0.25°C/bit		—	130		ms	7s/sec (typical)
0.25°C/bit		—	250		ms	4s/sec (typical)
Power Supply						
Operating Voltage Range	V _{DD}	2.7	—	5.5	V	
Operating Current	I _{DD}	—	200	400	µA	
Shutdown Current	I _{SHDN}	—	0.1	2	µA	
Power On Reset (POR)	V _{POR}	—	2.2	—	V	Threshold for falling V _{DD}
Power Supply Rejection, T _A = +25°C	Δ°C/ΔV _{DD}	—	-0.1	—	°C/V	V _{DD} = 2.7V to 5.5V
		—	±0.15	—	°C	V _{DD} = 3.3V+150 mV _{PP AC} (0 to 1 MHz)
Alert Output (Open-Drain output, external pull-up resistor required), see Section 5.2.3						
High-level Current (leakage)	I _{OH}	—	—	1	µA	V _{OH} = V _{DD} (Active-Low, Pull-up Resistor)
Low-level Voltage	V _{OL}	—	—	0.4	V	I _{OL} = 3 mA (Active-Low, Pull-up Resistor)
Thermal Response, from +25°C (Air) to +125°C (oil bath)						
DFN-8	t _{RES}	—	0.7	—	s	Time to 63% (89°C)
MSOP-8		—	1.4	—	s	

MCP9804

DIGITAL INPUT/OUTPUT PIN CHARACTERISTICS

Electrical Specifications: Unless otherwise indicated, $V_{DD} = 2.7V$ to $5.5V$, GND = Ground, and $T_A = -40^{\circ}C$ to $+125^{\circ}C$.

Parameters	Sym	Min	Typ	Max	Units	Conditions
Serial Input/Output (SCL, SDA, A0, A1, A2)						
Input						
High-level Voltage	V_{IH}	2.1	—	—	V	
Low-level Voltage	V_{IL}	—	—	0.8	V	
Input Current	I_{IN}	—	—	± 5	μA	
Output (SDA)						
Low-level Voltage	V_{OL}	—	—	0.4	V	$I_{OL} = 3\text{ mA}$
High-level Current (leakage)	I_{OH}	—	—	1	μA	$V_{OH} = 5.5V$
Low-level Current	I_{OL}	6	—	—	mA	$V_{OL} = 0.6V$
SDA and SCL Inputs						
Hysteresis	V_{HYST}	—	0.5	—	V	
Spike Suppression	t_{SP}	—	—	50	ns	
Capacitance	C_{IN}	—	5	—	pF	

GRAPHICAL SYMBOL DESCRIPTION

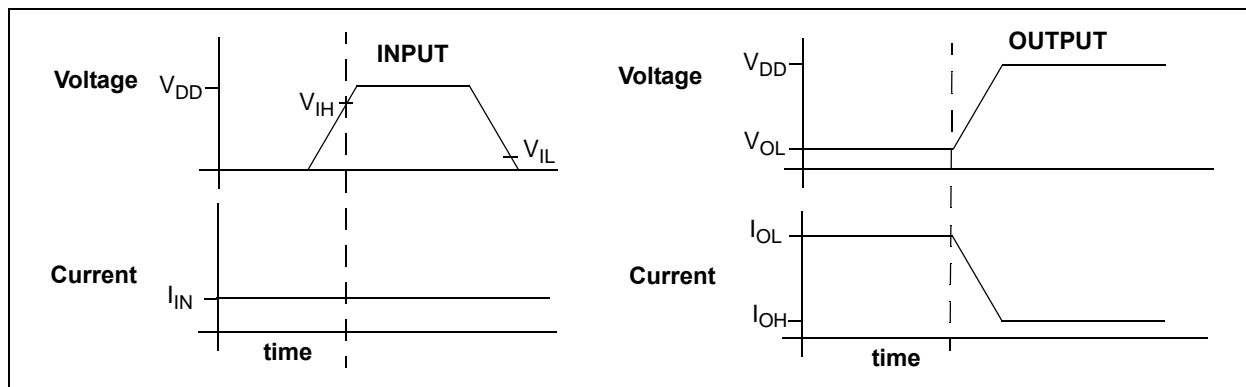

TEMPERATURE CHARACTERISTICS

Electrical Specifications: Unless otherwise indicated, $V_{DD} = 2.7V$ to $5.5V$ and GND = Ground.

Parameters	Sym	Min	Typ	Max	Units	Conditions
Temperature Ranges						
Specified Temperature Range	T_A	-40	—	+125	$^{\circ}C$	Note 1
Operating Temperature Range	T_A	-40	—	+125	$^{\circ}C$	
Storage Temperature Range	T_A	-65	—	+150	$^{\circ}C$	
Thermal Package Resistances						
Thermal Resistance, 8L-DFN	θ_{JA}	—	41	—	$^{\circ}C/W$	
Thermal Resistance, 8L-MSOP	θ_{JA}	—	206	—	$^{\circ}C/W$	

Note 1: Operation in this range must not cause T_J to exceed Maximum Junction Temperature ($+150^{\circ}C$).

SENSOR SERIAL INTERFACE TIMING SPECIFICATIONS

Electrical Specifications: Unless otherwise indicated, $V_{DD} = 2.7V$ to $5.5V$, $T_A = -40^{\circ}C$ to $+125^{\circ}C$, GND = Ground, and $C_L = 80$ pF (**Note**).

Parameters	Sym	Min	Max	Units	Conditions
2-Wire SMBus/Standard Mode I²C™ Compatible Interface (Note)					
Serial Port Clock Frequency	f_{SC}	10	—	100	kHz
Low Clock	t_{LOW}	4.7	—	—	μs
High Clock	t_{HIGH}	4.0	—	—	μs
Rise Time	t_R	—	—	1000	ns
Fall Time	t_F	—	—	300	ns
Data Setup Before SCL High	$t_{SU-DATA}$	250	—	—	ns
Data Hold After SCL Low	$t_{HD-DATA}$	300	—	—	ns
Start Condition Setup Time	$t_{SU-START}$	4.7	—	—	μs
Start Condition Hold Time	$t_{HD-START}$	4.0	—	—	μs
Stop Condition Setup Time	$t_{SU-STOP}$	4.0	—	—	μs
Bus Free	t_{B-FREE}	4.7	—	—	μs
Time Out	t_{OUT}	20	27	35	ms

Note: The serial interface specification min./max. limits are specified by characterization (not production tested).

TIMING DIAGRAM

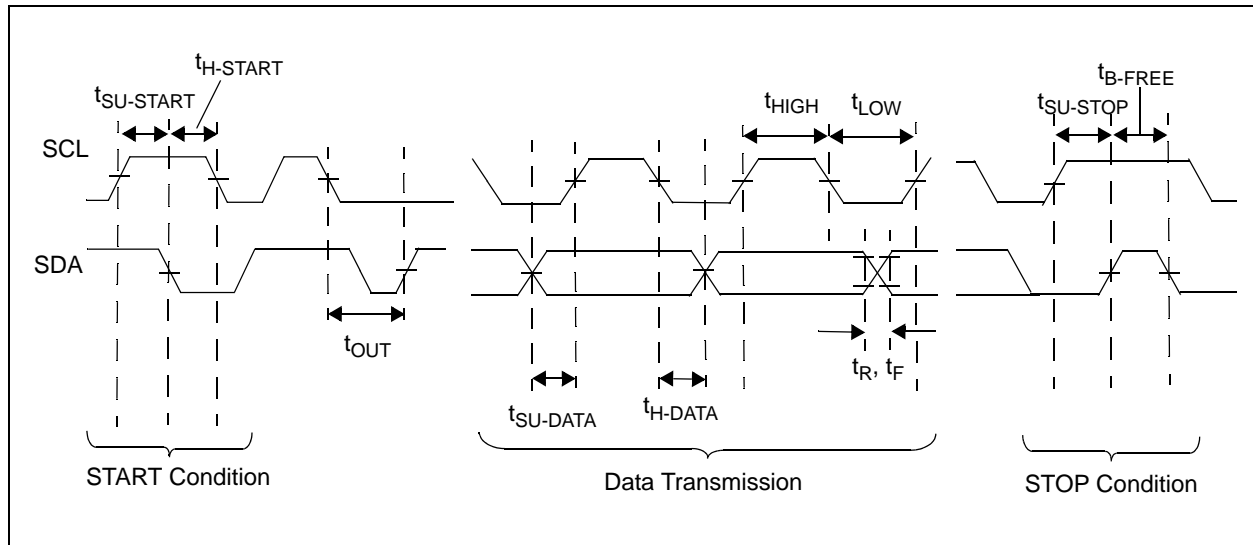

MCP9804

NOTES:

2.0 TYPICAL PERFORMANCE CURVES

Note: The graphs and tables provided following this note are a statistical summary based on a limited number of samples and are provided for informational purposes only. The performance characteristics listed herein are not tested or guaranteed. In some graphs or tables, the data presented may be outside the specified operating range (e.g., outside specified power supply range) and therefore outside the warranted range.

Note: Unless otherwise indicated, $V_{DD} = 2.7V$ to $5.5V$, GND = Ground, SDA/SCL pulled-up to V_{DD} , and $T_A = -40^{\circ}C$ to $+125^{\circ}C$.

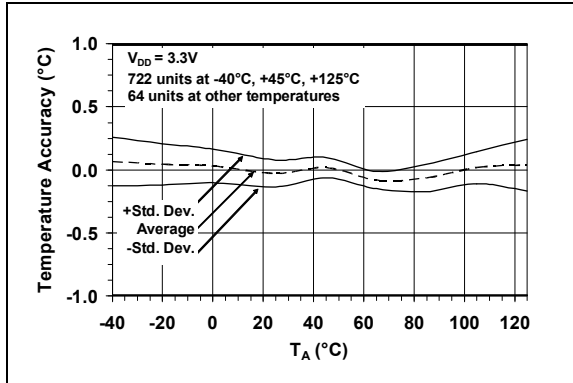

FIGURE 2-1: Temperature Accuracy.

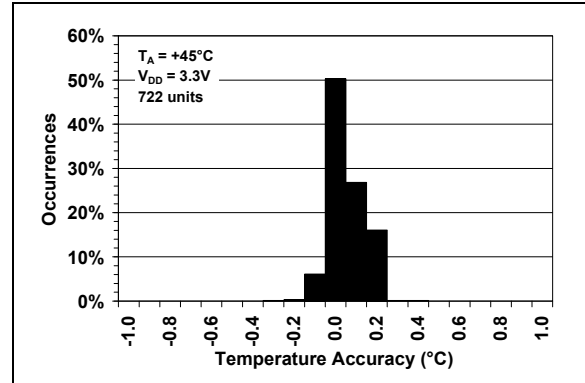

FIGURE 2-4: Temperature Accuracy Histogram, $T_A = +45^{\circ}C$.

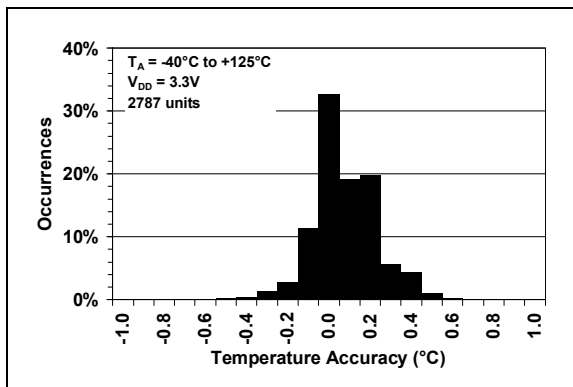

FIGURE 2-2: Temperature Accuracy Histogram, $T_A = -40^{\circ}C$ to $+125^{\circ}C$.

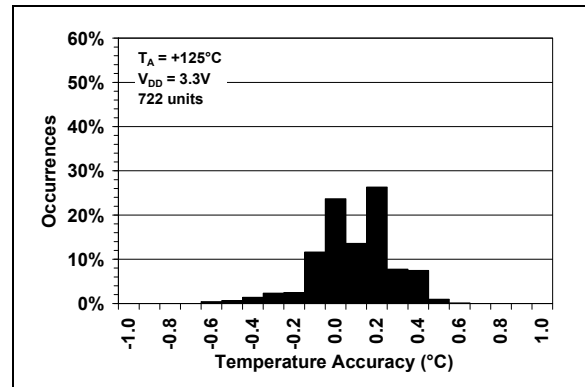

FIGURE 2-5: Temperature Accuracy Histogram, $T_A = +125^{\circ}C$.

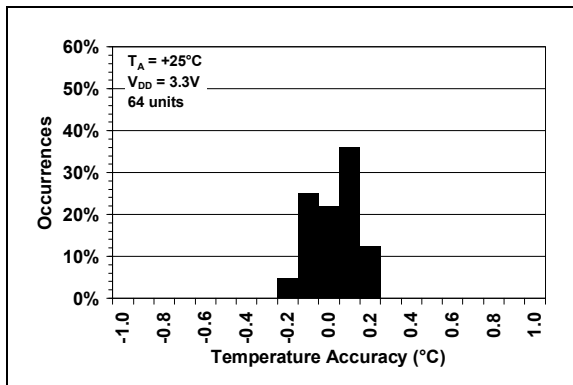

FIGURE 2-3: Temperature Accuracy Histogram, $T_A = +25^{\circ}C$.

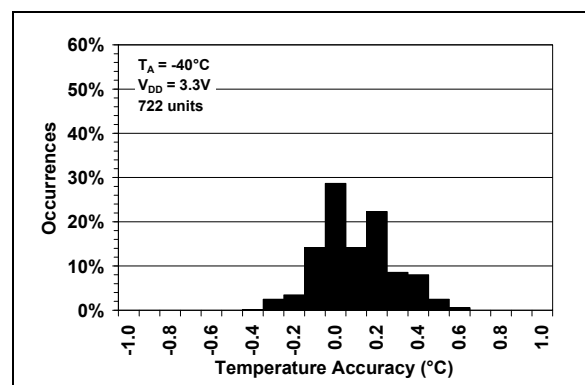

FIGURE 2-6: Temperature Accuracy Histogram, $T_A = -40^{\circ}C$.

MCP9804

Note: Unless otherwise indicated, $V_{DD} = 2.7V$ to $5.5V$, GND = Ground, SDA/SCL pulled-up to V_{DD} , and $T_A = -40^{\circ}C$ to $+125^{\circ}C$.

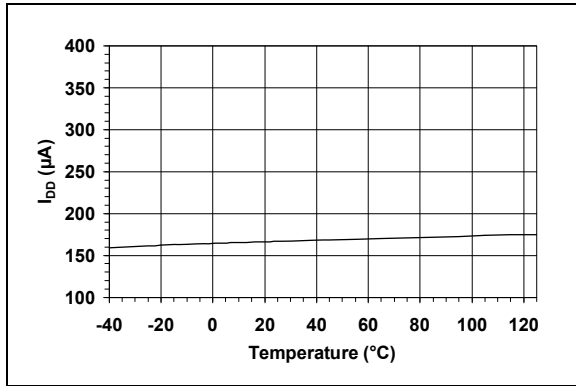

FIGURE 2-7: Supply Current vs. Temperature.

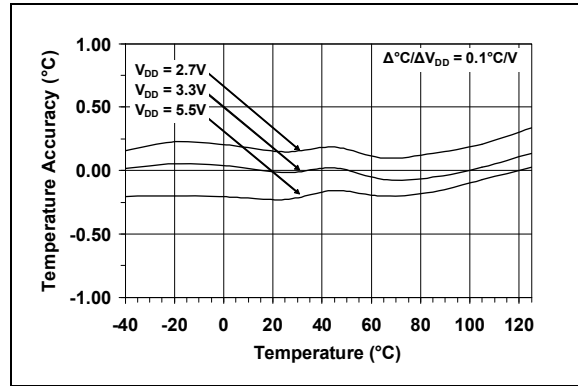

FIGURE 2-10: Temperature Accuracy vs. Supply Voltage.

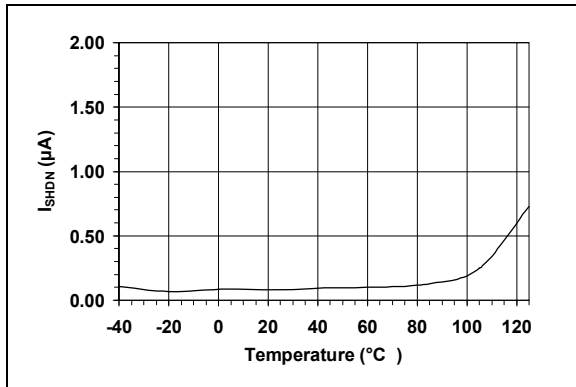

FIGURE 2-8: Shutdown Current vs. Temperature.

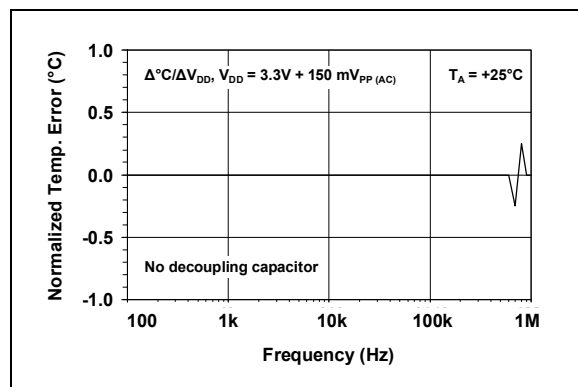

FIGURE 2-11: Power Supply Rejection vs. Frequency.

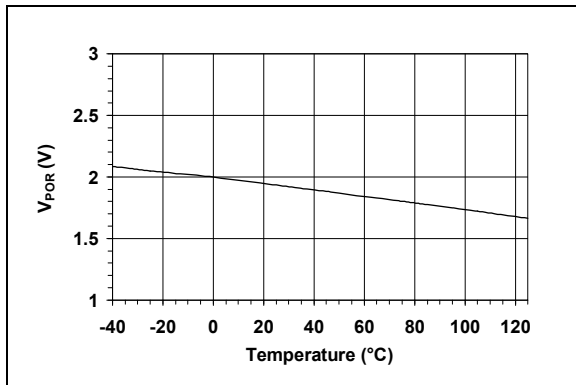

FIGURE 2-9: Power-on Reset Threshold Voltage vs. Temperature.

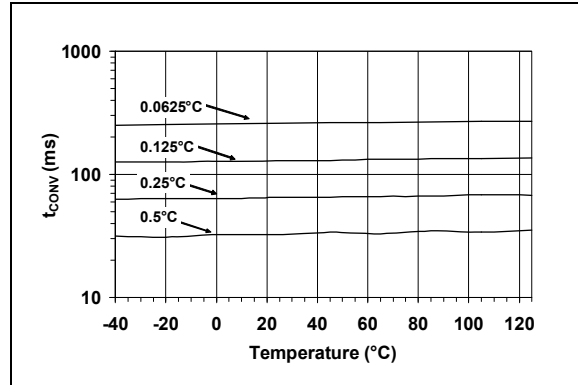

FIGURE 2-12: Temperature Conversion Time vs. Temperature.

Note: Unless otherwise indicated, $V_{DD} = 2.7V$ to $5.5V$, GND = Ground, SDA/SCL pulled-up to V_{DD} , and $T_A = -40^{\circ}C$ to $+125^{\circ}C$.

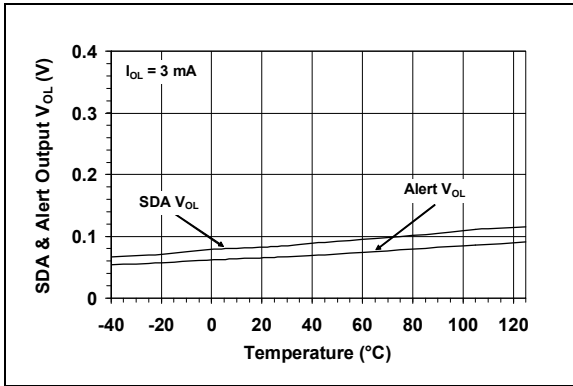

FIGURE 2-13: SDA & Alert output V_{OL} vs. Temperature.

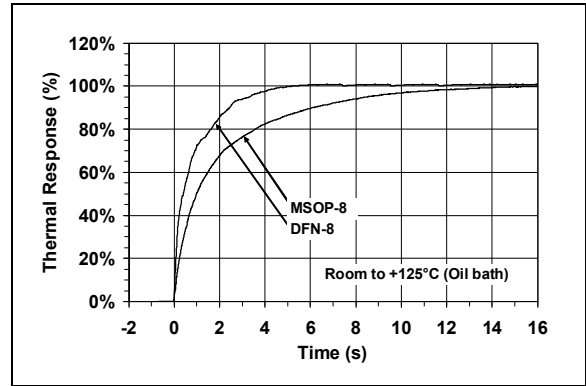

FIGURE 2-15: Package Thermal Response.

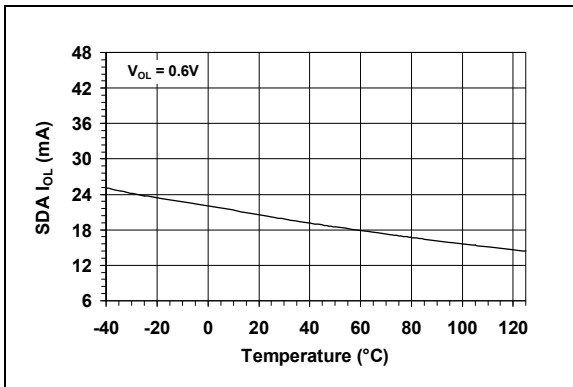

FIGURE 2-14: SDA I_{OL} vs. Temperature.

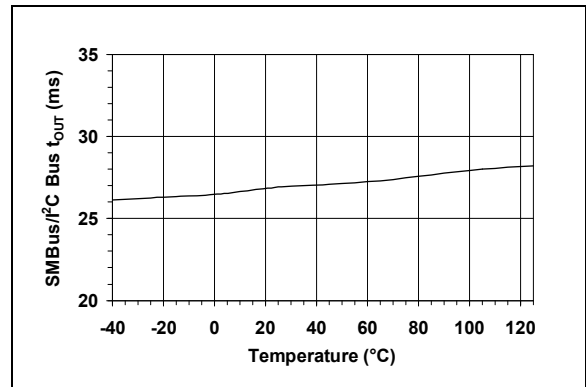

FIGURE 2-16: SMBus Timeout vs. Temperature.

MCP9804

NOTES:

3.0 PIN DESCRIPTION

The descriptions of the pins are listed in [Table 3-1](#).

TABLE 3-1: PIN FUNCTION TABLE

DFN	MSOP	Symbol	Pin Function
1	1	SDA	Serial Data Line
2	2	SCL	Serial Clock Line
3	3	Alert	Temperature Alert Output
4	4	GND	Ground
5	5	A2	Slave Address
6	6	A1	Slave Address
7	7	A0	Slave Address
8	8	V _{DD}	Power Pin
9	—	EP	Exposed Thermal Pad (EP); must be connected to GND.

3.1 Address Pins (A0, A1, A2)

These pins are device address input pins.

The address pins correspond to the Least Significant bits (LSb) of address bits. The Most Significant bits (MSb) (A6, A5, A4, A3). This is shown in [Table 3-2](#).

TABLE 3-2: MCP9804 ADDRESS BYTE

Device	Address Code				Slave Address		
	A6	A5	A4	A3	A2	A1	A0
MCP9804	0	0	1	1	X ⁽¹⁾	X	X
MCP9804 ⁽²⁾	1	0	0	1	X	X	X

Note 1: User-selectable address is shown by X. A2, A1 and A0 must match the corresponding device pin configuration.

2: Contact Factory for this Address Code.

3.2 Ground Pin (GND)

The GND pin is the system ground pin.

3.3 Serial Data Line (SDA)

SDA is a bidirectional input/output pin, used to serially transmit data to/from the host controller. This pin requires a pull-up resistor. (See [Section 4.0](#)).

3.4 Serial Clock Line (SCL)

The SCL is a clock input pin. All communication and timing is relative to the signal on this pin. The clock is generated by the host or master controller on the bus. (See [Section 4.0](#)).

3.5 Temperature Alert, Open-Drain Output (Alert)

The MCP9804 temperature alert output pin is an open-drain output. The device outputs a signal when the ambient temperature goes beyond the user-programmed temperature limit. (See [Section 5.2.3](#)).

3.6 Power Pin (V_{DD})

V_{DD} is the power pin. The operating voltage range, as specified in the DC electrical specification table, is applied on this pin.

3.7 Exposed Thermal Pad (EP)

There is an internal electrical connection between the Exposed Thermal Pad (EP) and the GND pin. The EP may be connected to the system ground on the Printed Circuit Board (PCB).

MCP9804

NOTES:

4.0 SERIAL COMMUNICATION

4.1 2-Wire Standard Mode I²C™ Protocol-Compatible Interface

The MCP9804 serial clock input (SCL) and the bidirectional serial data line (SDA) form a 2-wire bidirectional Standard mode I²C compatible communication port (refer to the **Digital Input/Output Pin Characteristics** table and **Sensor Serial Interface Timing Specifications** table).

The following bus protocol has been defined:

TABLE 4-1: MCP9804 SERIAL BUS PROTOCOL DESCRIPTIONS

Term	Description
Master	The device that controls the serial bus, typically a microcontroller.
Slave	The device addressed by the master, such as the MCP9804.
Transmitter	Device sending data to the bus.
Receiver	Device receiving data from the bus.
START	A unique signal from master to initiate serial interface with a slave.
STOP	A unique signal from the master to terminate serial interface from a slave.
Read/Write	A read or write to the MCP9804 registers.
ACK	A receiver Acknowledges (ACK) the reception of each byte by polling the bus.
NAK	A receiver Not-Acknowledges (NAK) or releases the bus to show End-of-Data (EOD).
Busy	Communication is not possible because the bus is in use.
Not Busy	The bus is in the idle state, both SDA and SCL remain high.
Data Valid	SDA must remain stable before SCL becomes high in order for a data bit to be considered valid. During normal data transfers, SDA only changes state while SCL is low.

4.1.1 DATA TRANSFER

Data transfers are initiated by a Start condition (START), followed by a 7-bit device address and a read/write bit. An Acknowledge (ACK) from the slave confirms the reception of each byte. Each access must be terminated by a Stop condition (STOP).

Repeated communication is initiated after t_{B-FREE} .

This device does not support sequential register read/write. Each register needs to be addressed using the Register Pointer.

This device supports the Receive Protocol. The register can be specified using the pointer for the initial read. Each repeated read or receive begins with a Start condition and address byte. The MCP9804 retains the previously selected register. Therefore, it outputs data from the previously-specified register (repeated pointer specification is not necessary).

4.1.2 MASTER/SLAVE

The bus is controlled by a master device (typically a microcontroller) that controls the bus access and generates the Start and Stop conditions. The MCP9804 is a slave device and does not control other devices in the bus. Both master and slave devices can operate as either transmitter or receiver. However, the master device determines which mode is activated.

4.1.3 START/STOP CONDITION

A high-to-low transition of the SDA line (while SCL is high) is the Start condition. All data transfers must be preceded by a Start condition from the master. A low-to-high transition of the SDA line (while SCL is high) signifies a Stop condition.

If a Start or Stop condition is introduced during data transmission, the MCP9804 releases the bus. All data transfers are ended by a Stop condition from the master.

4.1.4 ADDRESS BYTE

Following the Start condition, the host must transmit an 8-bit address byte to the MCP9804. The address for the MCP9804 Temperature Sensor is '0011, A2, A1, A0' in binary, where the A2, A1 and A0 bits are set externally by connecting the corresponding pins to V_{DD} '1' or GND '0'. The 7-bit address transmitted in the serial bit stream must match the selected address for the MCP9804 to respond with an ACK. Bit 8 in the address byte is a read/write bit. Setting this bit to '1' commands a read operation, while '0' commands a write operation (see [Figure 4-1](#)).

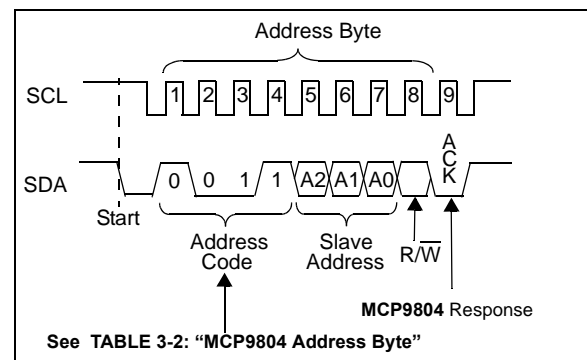

FIGURE 4-1: Device Addressing.

MCP9804

4.1.5 DATA VALID

After the Start condition, each bit of data in transmission needs to be settled for a time specified by $t_{SU-DATA}$ before SCL toggles from low-to-high (see the Sensor Serial Interface Timing Specifications section).

4.1.6 ACKNOWLEDGE (ACK/NAK)

Each receiving device, when addressed, is obliged to generate an ACK bit after the reception of each byte. The master device must generate an extra clock pulse for ACK to be recognized.

The acknowledging device pulls down the SDA line for $t_{SU-DATA}$ before the low-to-high transition of SCL from the master. SDA also needs to remain pulled down for t_{H-DATA} after a high-to-low transition of SCL.

During read, the master must signal an End-of-Data (EOD) to the slave by not generating an ACK bit (NAK) once the last bit has been clocked out of the slave. In this case, the slave will leave the data line released to enable the master to generate the Stop condition.

4.1.7 TIME OUT

If the SCL stays low or high for the time specified by t_{OUT} , the MCP9804 temperature sensor resets the serial interface. This dictates the minimum clock speed as specified in the specification.

5.0 FUNCTIONAL DESCRIPTION

The MCP9804 temperature sensors consists of a band-gap type temperature sensor, a Delta-Sigma Analog-to-Digital Converter ($\Sigma\Delta$ ADC), user-programmable registers and a 2-wire SMBus/I²C protocol compatible serial interface. Figure 5-1 shows a block diagram of the register structure.

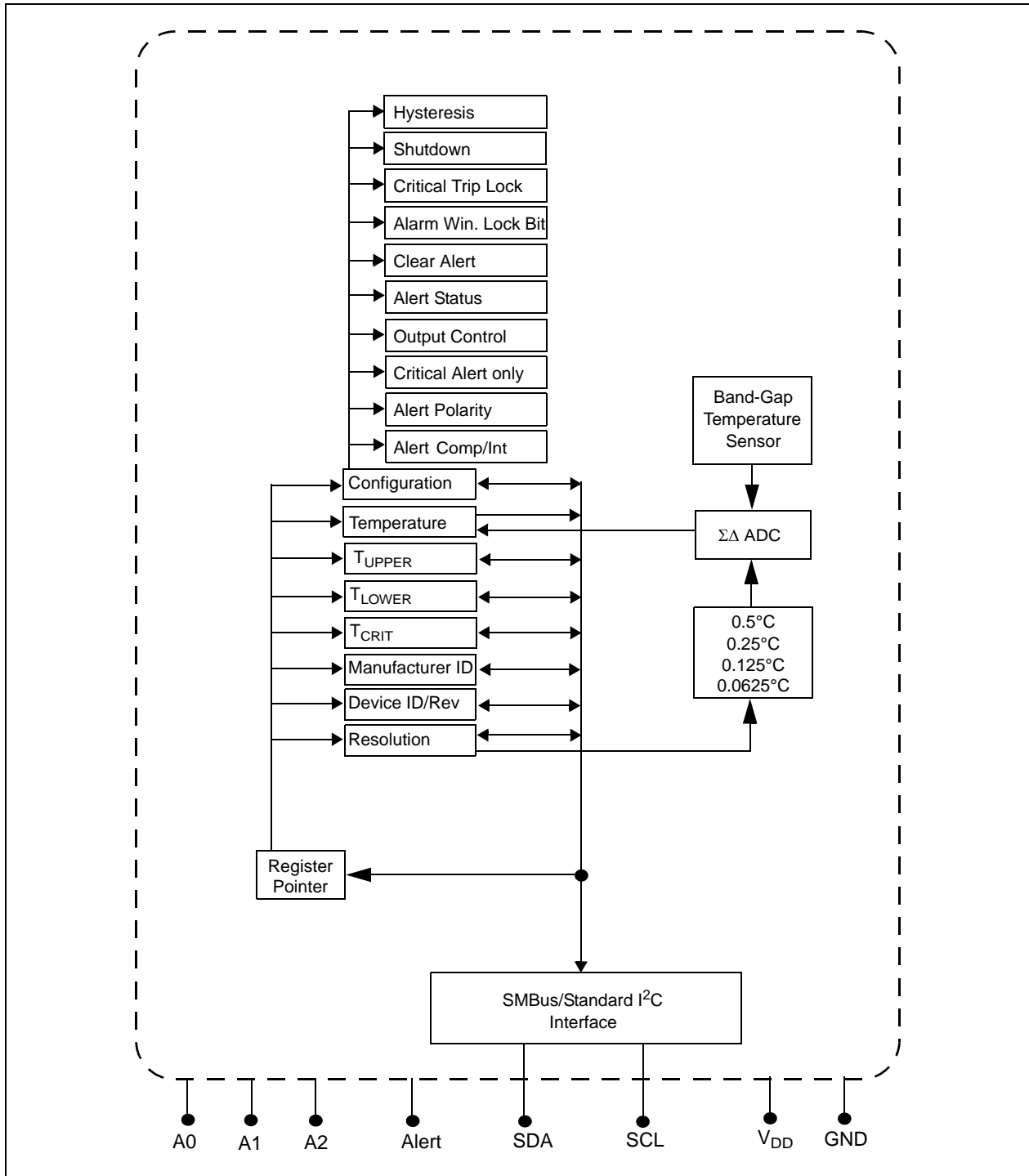

FIGURE 5-1: Functional Block Diagram.

MCP9804

5.1 Registers

The MCP9804 has several registers that are user-accessible. These registers include the Temperature register, Configuration register, Temperature Alert Upper-Boundary and Lower-Boundary Limit registers, Critical Temperature Limit register, Manufacturer Identification register and Device Identification register.

The Temperature register is read-only, used to access the ambient temperature data. This register is double buffered and it is updated every t_{CONV} . The Temperature Alert Upper-Boundary and Lower-Boundary Limit registers are read/writes registers. If the ambient temperature drifts beyond the user-specified limits, the MCP9804 outputs a signal using the Alert pin (refer to **Section 5.2.3**). In addition, the Critical Temperature Limit register is used to provide an additional critical temperature limit.

The Configuration register provides access to configure the MCP9804's various features. These registers are described in further detail in the following sections.

The registers are accessed by sending a Register Pointer to the MCP9804 using the serial interface. This is an 8-bit write-only pointer. However, the four Least Significant bits are used as pointers and all unused bits (bits 7-3) need to be cleared or set to '0'. [Register 5-1](#) describes the pointer or the address of each register.

REGISTER 5-1: REGISTER POINTER (WRITE ONLY)

W-0	W-0	W-0	W-0	W-0	W-0	W-0	W-0
—	—	—	—	Pointer Bits			
bit 7				bit 0			

Legend:			
R = Readable bit	W = Writable bit	U = Unimplemented bit, read as '0'	
-n = Value at POR	'1' = Bit is set	'0' = Bit is cleared	x = Bit is unknown

bit 7-4 **Writable Bits:** Write '0'
 Bits 7-4 must always be cleared or written to '0'. This device has additional registers that are reserved for test and calibration. If these registers are accessed, the device may not perform according to the specification.

bit 3-0 **Pointer Bits:**

- 0000 = RFU, reserved for future use (Read Only Register)
- 0001 = Configuration register (CONFIG)
- 0010 = Alert Temperature Upper-Boundary Trip register (T_{UPPER})
- 0011 = Alert Temperature Lower-Boundary Trip register (T_{LOWER})
- 0100 = Critical Temperature Trip register (T_{CRIT})
- 0101 = Temperature register (T_A)
- 0110 = Manufacturer ID register
- 0111 = Device ID/Revision register
- 1000 = Resolution register
- 1XXX = RFU (**Note**)

Note: Some registers contain calibration codes and should not be accessed. Accessing these registers could cause permanent sensor decalibration.

TABLE 5-1: BIT ASSIGNMENT SUMMARY FOR ALL REGISTERS (SEE SECTION 5.3 FOR POWER-ON DEFAULTS)

Register Pointer (Hex)	MSB/LSB	Bit Assignment							
		7	6	5	4	3	2	1	0
0x00	MSB	0	0	0	0	0	0	0	0
	LSB	0	0	0	1	1	1	1	1
0x01	MSB	0	0	0	0	0	Hysteresis		SHDN
	LSB	Crt Loc	Win Loc	Int Clr	Alt Stat	Alt Cnt	Alt Sel	Alt Pol	Alt Mod
0x02	MSB	0	0	0	SIGN	2 ⁷ °C	2 ⁶ °C	2 ⁵ °C	2 ⁴ °C
	LSB	2 ³ °C	2 ² °C	2 ¹ °C	2 ⁰ °C	2 ⁻¹ °C	2 ⁻² °C	0	0
0x03	MSB	0	0	0	SIGN	2 ⁷ °C	2 ⁶ °C	2 ⁵ °C	2 ⁴ °C
	LSB	2 ³ °C	2 ² °C	2 ¹ °C	2 ⁰ °C	2 ⁻¹ °C	2 ⁻² °C	0	0
0x04	MSB	0	0	0	SIGN	2 ⁷ °C	2 ⁶ °C	2 ⁵ °C	2 ⁴ °C
	LSB	2 ³ °C	2 ² °C	2 ¹ °C	2 ⁰ °C	2 ⁻¹ °C	2 ⁻² °C	0	0
0x05	MSB	T _A ≥ T _{CRIT}	T _A > T _{UPPER}	T _A < T _{LOWER}	SIGN	2 ⁷ °C	2 ⁶ °C	2 ⁵ °C	2 ⁴ °C
	LSB	2 ³ °C	2 ² °C	2 ¹ °C	2 ⁰ °C	2 ⁻¹ °C	2 ⁻² °C	0	0
0x06	MSB	0	0	0	0	0	0	0	0
	LSB	0	1	0	1	0	1	0	0
0x07	MSB	0	0	0	0	0	0	1	0
	LSB	0	0	0	0	0	0	0	0
0x08	LSB	0	0	0	0	0	0	1	1

MCP9804

5.1.1 SENSOR CONFIGURATION REGISTER (CONFIG)

The MCP9804 has a 16-bit Configuration register (CONFIG) that allows the user to set various functions for a robust temperature monitoring system. Bits 10 thru 0 are used to select Temperature Alert output hysteresis, device Shutdown or Low-Power mode, temperature boundary and critical temperature lock, and temperature Alert output enable/disable. In addition, Alert output condition (output set for T_{UPPER} and T_{LOWER} temperature boundary or T_{CRIT} only), Alert output status and Alert output polarity and mode (Comparator Output or Interrupt Output mode) are user configurable.

The temperature hysteresis bits 10 and 9 can be used to prevent output chatter when the ambient temperature gradually changes beyond the user-specified temperature boundary (see

Section 5.2.2. The Continuous Conversion or Shutdown mode is selected using bit 8. In Shutdown mode, the band gap temperature sensor circuit stops converting temperature and the Ambient Temperature register (T_A) holds the previous temperature data (see **Section 5.2.1**). Bits 7 and 6 are used to lock the user-specified boundaries T_{UPPER}, T_{LOWER} and T_{CRIT} to prevent an accidental rewrite. The Lock bits are cleared by resetting power. Bits 5 thru 0 are used to configure the temperature Alert output pin. All functions are described in [Register 5-2](#) (see **Section 5.2.3**).

REGISTER 5-2: CONFIGURATION REGISTER (CONFIG) → ADDRESS '0000 0001'b

U-0	U-0	U-0	U-0	U-0	R/W-0	R/W-0	R/W-0
—	—	—	—	—	T _{HYST}		SHDN
bit 15						bit 8	

R/W-0	R/W-0	R/W-0	R-0	R/W-0	R/W-0	R/W-0	R/W-0
Crit. Lock	Win. Lock	Int. Clear	Alert Stat.	Alert Cnt.	Alert Sel.	Alert Pol.	Alert Mod.
bit 7						bit 0	

Legend:

R = Readable bit W = Writable bit U = Unimplemented bit, read as '0'
 -n = Value at POR '1' = Bit is set '0' = Bit is cleared x = Bit is unknown

bit 15-11 **Unimplemented:** Read as '0'

bit 10-9 **T_{UPPER} and T_{LOWER} Limit Hysteresis (T_{HYST}):**

- 00 = 0°C (power-up default)
- 01 = 1.5°C
- 10 = 3.0°C
- 11 = 6.0°C

(Refer to **Section 5.2.3**)

This bit can not be altered when either of the lock bits are set (bit 6 and bit 7).

This bit can be programmed in shutdown mode.

bit 8 **Shutdown Mode (SHDN):**

- 0 = Continuous Conversion (power-up default)
- 1 = Shutdown (Low-Power mode)

In shutdown, all power-consuming activities are disabled, though all registers can be written to or read.

This bit cannot be set '1' when either of the lock bits is set (bit 6 and bit 7). However, it can be cleared '0' for Continuous Conversion while locked. (Refer to **Section 5.2.1**).

REGISTER 5-2: CONFIGURATION REGISTER (CONFIG) → ADDRESS '0000 0001'b

bit 7	<p>T_{CRIT} Lock Bit (Crit. Lock): 0 = Unlocked. T_{CRIT} register can be written (power-up default). 1 = Locked. T_{CRIT} register can not be written.</p> <p>When enabled, this bit remains set '1' or locked until cleared by internal reset (Section 5.3). This bit does not require a double-write.</p> <p>This bit can be programmed in shutdown mode.</p>
bit 6	<p>T_{UPPER} and T_{LOWER} Window Lock Bit (Win. Lock): 0 = Unlocked. T_{UPPER} and T_{LOWER} registers can be written (power-up default). 1 = Locked. T_{UPPER} and T_{LOWER} registers can not be written.</p> <p>When enabled, this bit remains set '1' or locked until cleared by power-on Reset (Section 5.3). This bit does not require a double-write.</p> <p>This bit can be programmed in shutdown mode.</p>
bit 5	<p>Interrupt Clear (Int. Clear) Bit: 0 = No effect (power-up default) 1 = Clear interrupt output. When read this bit returns '0'</p> <p>This bit can not be set '1' in shutdown mode, but it can be cleared after the device enters shutdown mode.</p>
bit 4	<p>Alert Output Status (Alert Stat.) Bit: 0 = Alert output is not asserted by the device (power-up default) 1 = Alert output is asserted as a comparator/Interrupt or critical temperature output</p> <p>This bit can not be set '1' or cleared '0' in shutdown mode. However, if the Alert output is configured as interrupt mode, and if the host controller clears '0' the interrupt using bit 5 while the device is in shutdown mode then this bit will also be cleared '0'.</p>
bit 3	<p>Alert Output Control (Alert Cnt.) Bit: 0 = Disabled (power-up default) 1 = Enabled</p> <p>This bit can not be altered when either of the lock bits is set (bit 6 and bit 7).</p> <p>This bit can be programmed in shutdown mode, but the Alert output will not assert or de-assert.</p>
bit 2	<p>Alert Output Select (Alert Sel.) Bit: 0 = Alert output for T_{UPPER}, T_{LOWER} and T_{CRIT} (power-up default) 1 = T_A > T_{CRIT} only. (T_{UPPER} and T_{LOWER} temperature boundaries are disabled.)</p> <p>When the Alarm Window Lock bit is set, this bit cannot be altered until unlocked (bit 6).</p> <p>This bit can be programmed in shutdown mode, but the Alert output will not assert or de-assert.</p>
bit 1	<p>Alert Output Polarity (Alert Pol.) Bit: 0 = Active low (power-up default. Pull-up resistor required) 1 = Active-high</p> <p>This bit cannot be altered when either of the lock bits is set (bit 6 and bit 7).</p> <p>This bit can be programmed in shutdown mode, but the Alert output will not assert or de-assert.</p>
bit 0	<p>Alert Output Mode (Alert Mod.) Bit: 0 = Comparator output (power-up default) 1 = Interrupt output</p> <p>This bit cannot be altered when either of the lock bits is set (bit 6 and bit 7).</p> <p>This bit can be programmed in shutdown mode, but the Alert output will not assert or de-assert.</p>

MCP9804

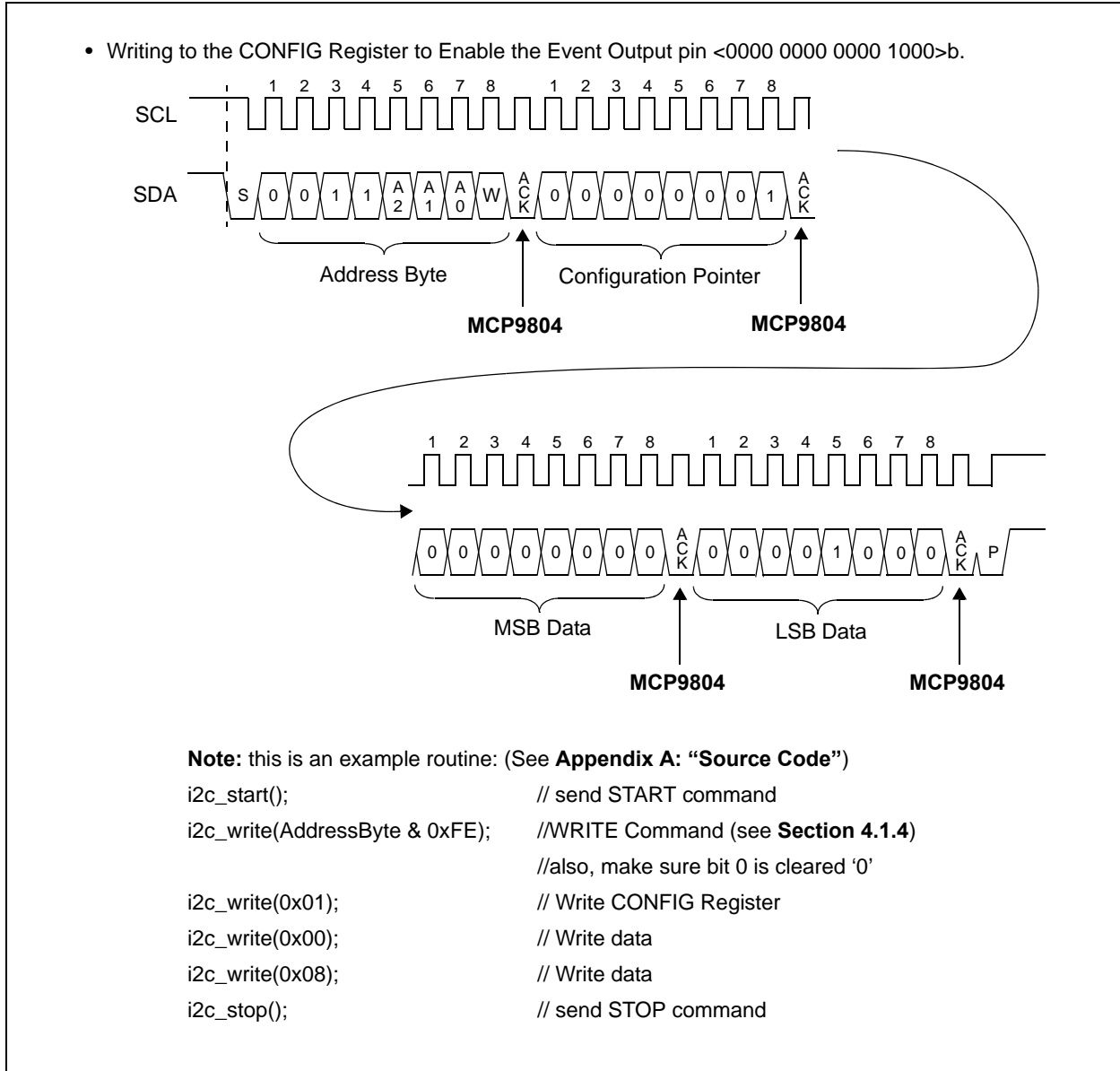

FIGURE 5-2: Timing Diagram for Writing to the Configuration Register (See **Section 4.0**.)

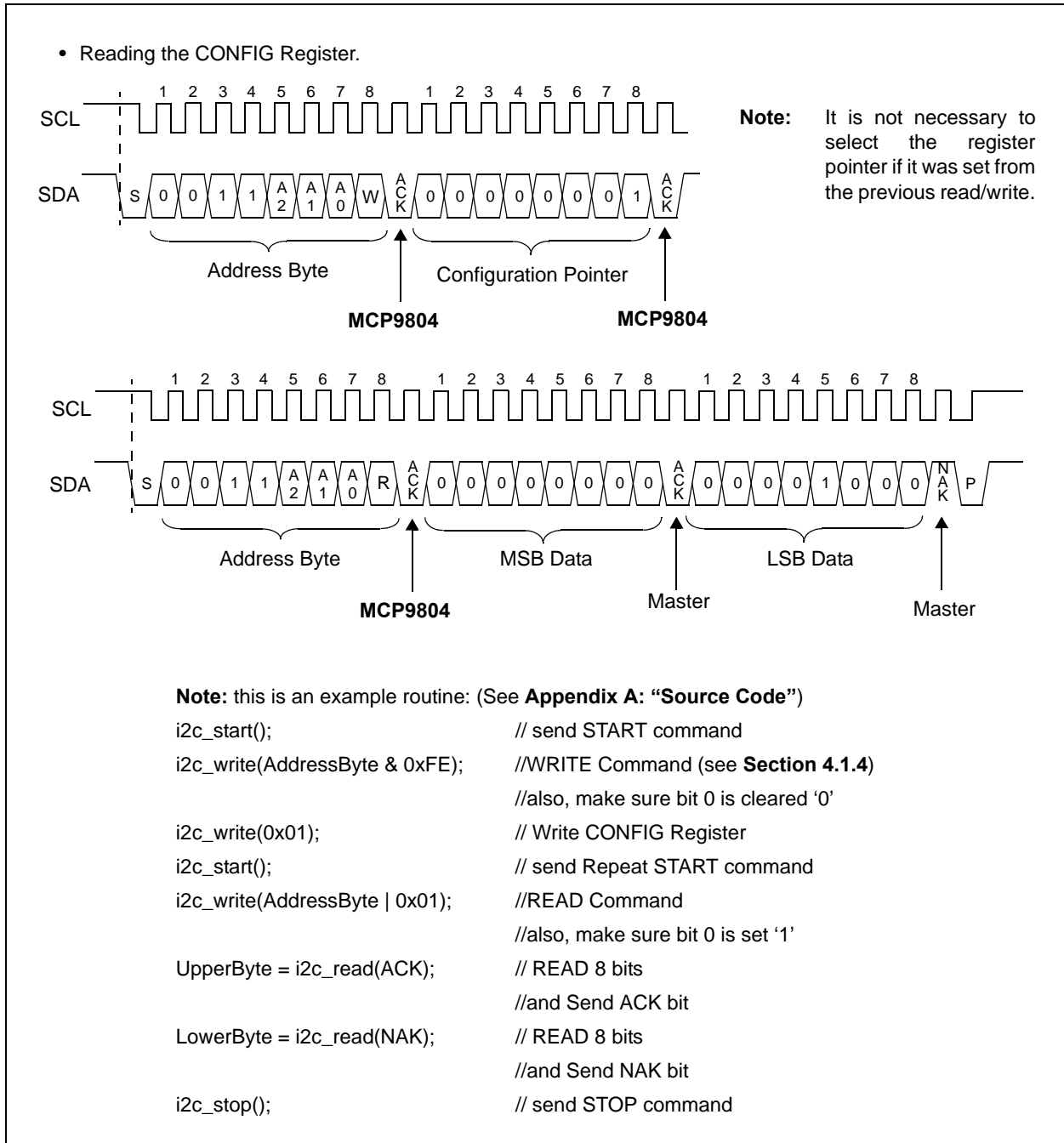

FIGURE 5-3: Timing Diagram for Reading from the Configuration Register (See **Section 4.0**).

MCP9804

5.1.2 UPPER/LOWER/CRITICAL TEMPERATURE LIMIT REGISTERS ($T_{UPPER}/T_{LOWER}/T_{CRIT}$)

The MCP9804 has a 16-bit read/write Alert Output Temperature Upper-Boundary register (T_{UPPER}), a 16-bit Lower-Boundary register (T_{LOWER}) and a 16-bit Critical Boundary register (T_{CRIT}) that contains 11-bit data in two's complement format (0.25°C). This data represents the maximum and minimum temperature boundary or temperature window that can be used to monitor ambient temperature. If this feature is enabled (**Section 5.1.1**) and the ambient temperature exceeds the specified boundary or window, the MCP9804 asserts an Alert output. (Refer to **Section 5.2.3**).

REGISTER 5-3: UPPER/LOWER/CRITICAL TEMPERATURE LIMIT REGISTER ($T_{UPPER}/T_{LOWER}/T_{CRIT}$) → ADDRESS '0000 0010'b/'0000 0011'b/'0000 0100'b (NOTE)

U-0	U-0	U-0	R/W-0	R/W-0	R/W-0	R/W-0	R/W-0	
—	—	—	Sign	2^7°C	2^6°C	2^5°C	2^4°C	
bit 15								bit 8

R/W-0	R/W-0	R/W-0	R/W-0	R/W-0	R/W-0	U-0	U-0	
2^3°C	2^2°C	2^1°C	2^0°C	$2^{-1^{\circ}\text{C}}$	$2^{-2^{\circ}\text{C}}$	—	—	
bit 7								bit 0

Legend:

R = Readable bit

W = Writable bit

U = Unimplemented bit, read as '0'

-n = Value at POR

'1' = Bit is set

'0' = Bit is cleared

x = Bit is unknown

bit 15-13 **Unimplemented:** Read as '0'

bit 12 **Sign:**

0 = $T_A \geq 0^{\circ}\text{C}$

1 = $T_A < 0^{\circ}\text{C}$

bit 11-2 **$T_{UPPER}/T_{LOWER}/T_{CRIT}$:**

Temperature boundary trip data in two's complement format.

bit 1-0 **Unimplemented:** Read as '0'

Note: This table shows two 16-bit registers for T_{UPPER} , T_{LOWER} and T_{CRIT} located at '0000 0010b', '0000 0011b' and '0000 0100b', respectively.

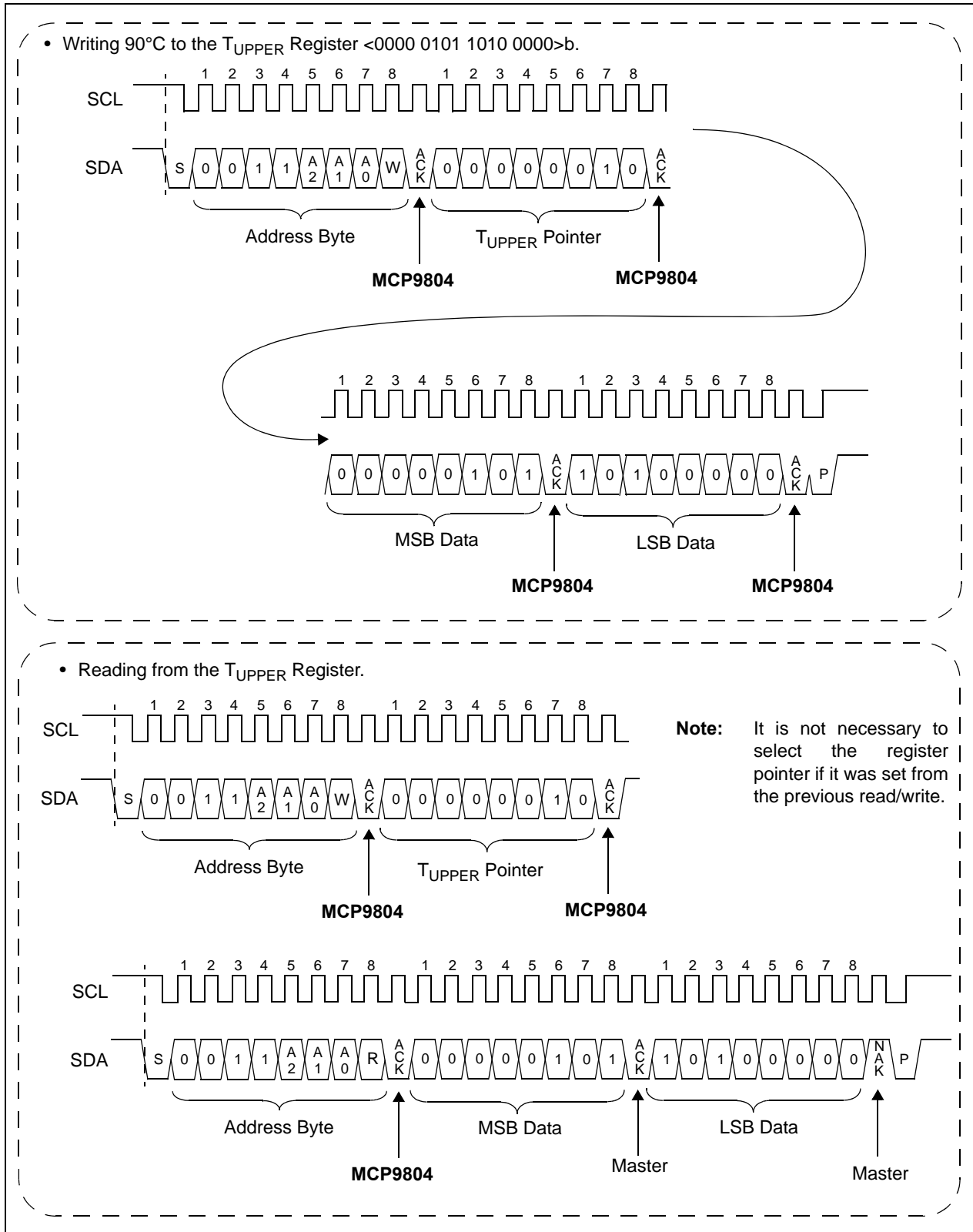

FIGURE 5-4: Timing Diagram for Writing and Reading from the T_{UPPER} Register (See Section 4.0).

MCP9804

5.1.3 AMBIENT TEMPERATURE REGISTER (T_A)

The MCP9804 uses a band gap temperature sensor circuit to output analog voltage proportional to absolute temperature. An internal $\Delta\Sigma$ ADC is used to convert the analog voltage to a digital word. The digital word is loaded to a 16-bit read-only Ambient Temperature register (T_A) that contains 13-bit temperature data in two's complement format.

The T_A register bits (bits 12 thru 0) are double-buffered. Therefore, the user can access the register while, in the background, the MCP9804 performs an analog-to-digital conversion. The temperature data from the $\Delta\Sigma$ ADC is loaded in parallel to the T_A register at t_{CONV} refresh rate.

In addition, the T_A register uses three bits (bits 15, 14 and 13) to reflect the Alert pin state. This allows the user to identify the cause of the Alert output trigger (see **Section 5.2.3**); bit 15 is set to '1' if T_A is greater than or equal to T_{CRIT} , bit 14 is set to '1' if T_A is greater than T_{UPPER} and bit 13 is set to '1' if T_A is less than T_{LOWER} .

The T_A register bit assignment and boundary conditions are described in [Register 5-4](#).

REGISTER 5-4: AMBIENT TEMPERATURE REGISTER (T_A) → ADDRESS '0000 0101'b (NOTE 1)

R-0	R-0	R-0	R-0	R-0	R-0	R-0	R-0
T_A vs. T_{CRIT}	T_A vs. T_{UPPER}	T_A vs. T_{LOWER}	SIGN	2^7 °C	2^6 °C	2^5 °C	2^4 °C
bit 15							bit 8

R-0	R-0	R-0	R-0	R-0	R-0	R-0	R-0
2^3 °C	2^2 °C	2^1 °C	2^0 °C	2^{-1} °C	2^{-2} °C	2^{-3} °C	2^{-4} °C
bit 7							bit 0

Legend:

R = Readable bit	W = Writable bit	U = Unimplemented bit, read as '0'
-n = Value at POR	'1' = Bit is set	'0' = Bit is cleared
		x = Bit is unknown

bit 15 T_A vs. T_{CRIT} (Note 1) Bit:

0 = $T_A < T_{CRIT}$
1 = $T_A \geq T_{CRIT}$

bit 14 T_A vs. T_{UPPER} (Note 1) Bit:

0 = $T_A \leq T_{UPPER}$
1 = $T_A > T_{UPPER}$

bit 13 T_A vs. T_{LOWER} (Note 1) Bit:

0 = $T_A \geq T_{LOWER}$
1 = $T_A < T_{LOWER}$

bit 12 SIGN Bit:

0 = $T_A \geq 0^\circ\text{C}$
1 = $T_A < 0^\circ\text{C}$

bit 11-0 Ambient Temperature (T_A) Bits: (Note 2)

12-bit Ambient Temperature data in two's complement format.

Note 1: Bits 15, 14 and 13 are not affected by the status of the Alert output configuration (bits 5 to 0 of CONFIG) ([Register 5-2](#)).

2: Bits 2, 1, and 0 may remain clear '0' depending on the status of the resolution register ([Register 5-7](#)). The Power-up default is 0.25°C/bit, bits 1 and 0 remain clear '0'.

5.1.3.1 T_A bits to Temperature Conversion

To convert the T_A bits to decimal temperature, the upper three boundary bits (bits 15, 14 and 13) must be masked out. Then determine the sign bit (bit 12) to check positive or negative temperature, shift the bits accordingly and combine the upper and lower bytes of the 16-bit register. The upper byte contains data for temperatures greater than 32°C while the lower byte contains data for temperature less than 32°C, including fractional data. When combining the upper and lower bytes, the upper byte must be Right-shifted by 4 bits (or multiply by 2^4) and the lower byte must be Left-shifted by 4 bits (or multiply by 2^{-4}). Adding the results of the shifted values provides the temperature data in decimal format, see [Equation 5-1](#).

The temperature bits are in two's compliment format, therefore, positive temperature data and negative temperature data are computed differently. [Equation 5-1](#) shows the temperature computation. The example instruction code outlined in [Figure 5-5](#) shows the communication flow, also see [Figure 5-6](#) for timing diagram.

EQUATION 5-1: BYTES TO TEMPERATURE CONVERSION

Temperature $T_A \geq 0^\circ\text{C}$

$$T_A = (\text{UpperByte} \times 2^4 + \text{LowerByte} \times 2^{-4})$$

Temperature $< 0^\circ\text{C}$

$$T_A = 256 - (\text{UpperByte} \times 2^4 + \text{LowerByte} \times 2^{-4})$$

Where:

T_A = Ambient Temperature ($^\circ\text{C}$)

UpperByte = T_A bit 15 to bit 8

LowerByte = T_A bit 7 to bit 0

This example routine assumes the variables and i2c communication subroutines are predefined:
(See [Appendix A: "Source Code"](#))

```

i2c_start(); // send START command
i2c_write (AddressByte & 0xFE); //WRITE Command (see Section 4.1.4)
//also, make sure bit 0 is cleared '0'

i2c_write(0x05); // Write  $T_A$  Register Address
i2c_start(); //Repeat START
i2c_write(AddressByte | 0x01); // READ Command (see Section 4.1.4)
//also, make sure bit 0 is Set '1'

UpperByte = i2c_read(ACK); // READ 8 bits
//and Send ACK bit

LowerByte = i2c_read(NAK); // READ 8 bits
//and Send NAK bit

i2c_stop(); // send STOP command

//Convert the temperature data
//First Check flag bits
if ((UpperByte & 0x80) == 0x80){ //  $T_A \geq T_{\text{CRIT}}$ 
}
if ((UpperByte & 0x40) == 0x40){ //  $T_A > T_{\text{UPPER}}$ 
}
if ((UpperByte & 0x20) == 0x20){ //  $T_A < T_{\text{LOWER}}$ 
}
UpperByte = UpperByte & 0x1F; //Clear flag bits
if ((UpperByte & 0x10) == 0x10){ //  $T_A < 0^\circ\text{C}$ 
    UpperByte = UpperByte & 0x0F; //Clear SIGN
    Temperature = 256 - (UpperByte x 16 + LowerByte / 16);
}else //  $T_A \geq 0^\circ\text{C}$ 
    Temperature = (UpperByte x 16 + LowerByte / 16);
//Temperature = Ambient Temperature ( $^\circ\text{C}$ )
    
```

FIGURE 5-5: Example Instruction Code.

MCP9804

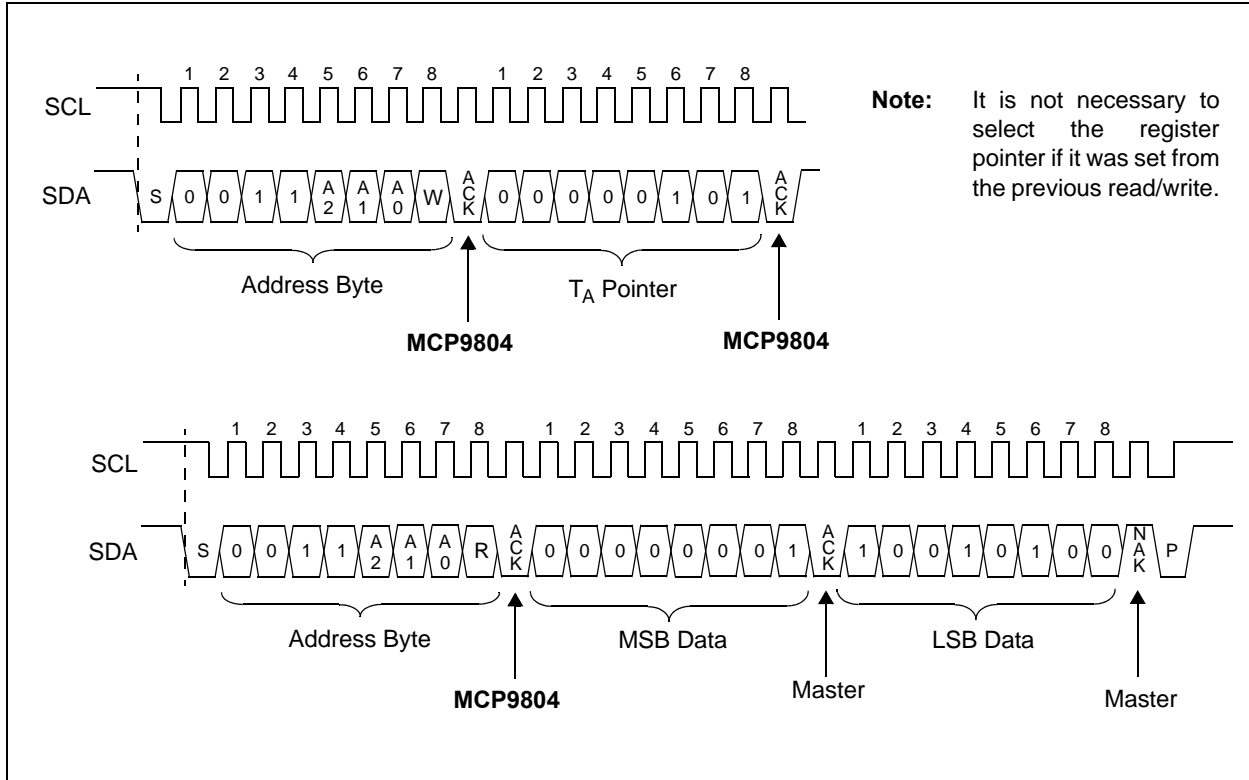

FIGURE 5-6: Timing Diagram for Reading +25.25°C Temperature from the T_A Register (See Section 4.0).

5.1.4 MANUFACTURER ID REGISTER

This register is used to identify the manufacturer of the device in order to perform manufacturer specific operation. The Manufacturer ID for the MCP9804 is 0x0054 (hexadecimal).

REGISTER 5-5: MANUFACTURER ID REGISTER (READ-ONLY) → ADDRESS '0000 0110'b

R-0	R-0	R-0	R-0	R-0	R-0	R-0	R-0
Manufacturer ID							
bit 15				bit 8			

R-0	R-1	R-0	R-1	R-0	R-1	R-0	R-0
Manufacturer ID							
bit 7				bit 0			

Legend:

R = Readable bit

W = Writable bit

U = Unimplemented bit, read as '0'

-n = Value at POR

'1' = Bit is set

'0' = Bit is cleared

x = Bit is unknown

bit 15-0 Device Manufacturer Identification Bits

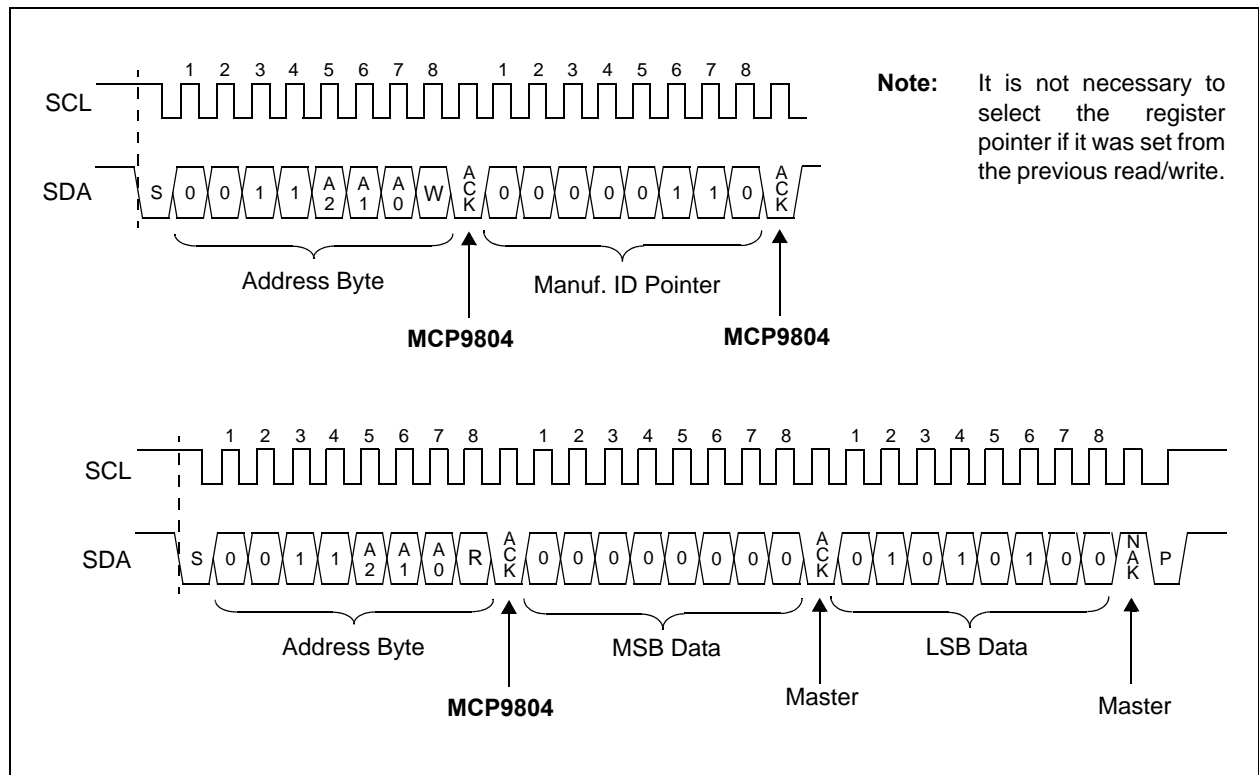

FIGURE 5-7: Timing Diagram for Reading the Manufacturer ID Register (See Section 4.0).

MCP9804

5.1.5 DEVICE ID AND REVISION REGISTER

The upper byte of this register is used to specify the device identification and the lower byte is used to specify device revision. The device ID for the MCP9804 is 0x02 (hex).

The revision begins with 0x00 (hex) for the first release, with the number being incremented as revised versions are released.

REGISTER 5-6: DEVICE ID AND DEVICE REVISION (READ-ONLY) → ADDRESS '0000 0111'b

R-0	R-0	R-0	R-0	R-0	R-0	R-1	R-0
Device ID							
bit 15							
bit 8							

R-0	R-0	R-0	R-0	R-0	R-0	R-0	R-0
Device Revision							
bit 7							
bit 0							

Legend:

R = Readable bit

W = Writable bit

U = Unimplemented bit, read as '0'

-n = Value at POR

'1' = Bit is set

'0' = Bit is cleared

x = Bit is unknown

bit 15-8 **Device ID:** Bit 15 to bit 8 are used for device ID

bit 7-0 **Device Revision:** Bit 7 to bit 0 are used for device revision

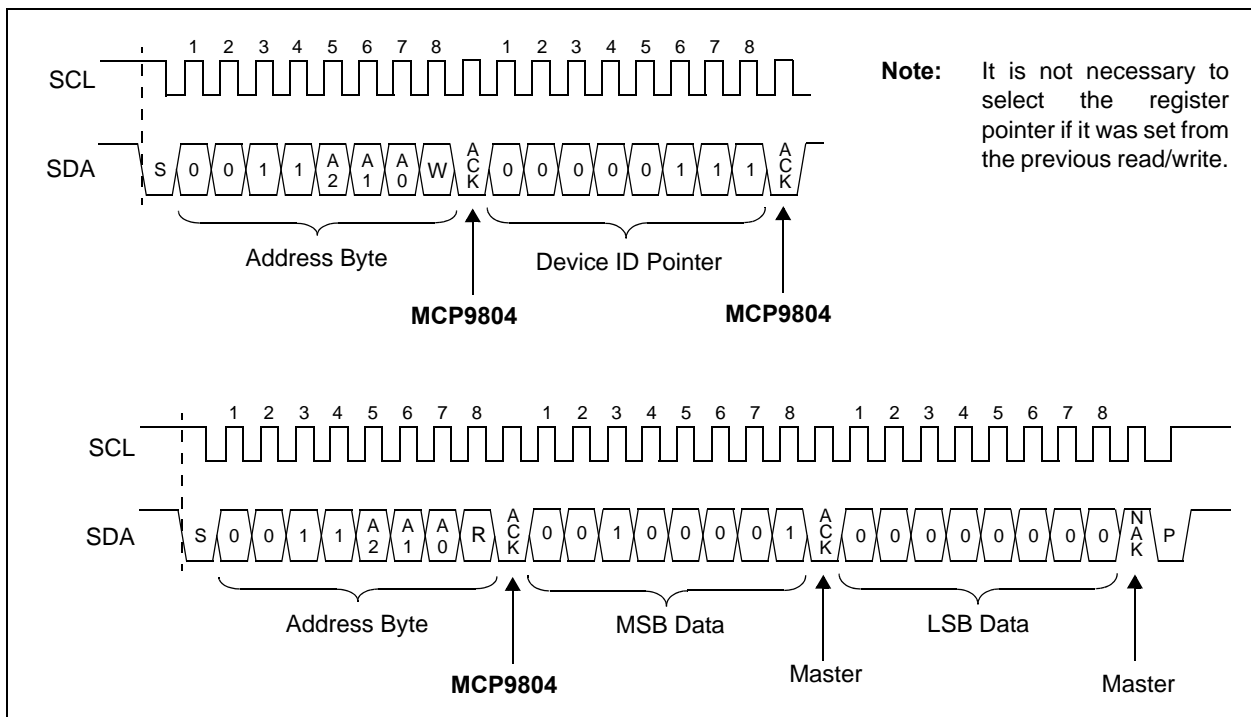

FIGURE 5-8: Timing Diagram for Reading Device ID and Device Revision Register (See Section 4.0).

5.1.6 RESOLUTION REGISTER

This register allows the user to change the sensor resolution (see **Section 5.2.4**). The POR default resolution is 0.25°C. The selected resolution is also reflected in the Capability register (see **Register 5-2**).

REGISTER 5-7: RESOLUTION → ADDRESS `'0000 1000'b`

U-0	U-0	U-0	U-0	U-0	U-0	R/W-1	R/W-1
—	—	—	—	—	—	Resolution	
bit 7						bit 0	

Legend:

R = Readable bit	W = Writable bit	U = Unimplemented bit, read as '0'
-n = Value at POR	'1' = Bit is set	'0' = Bit is cleared
		x = Bit is unknown

bit 7-3 **Unimplemented:** Read as '0'

bit 2-0 **Resolution:**

- 00 = LSB = 0.5°C (t_{CONV} = 30 ms typical)
- 01 = LSB = 0.25°C (t_{CONV} = 65 ms typical)
- 10 = LSB = 0.125°C (t_{CONV} = 130 ms typical)
- 11 = LSB = 0.0625°C (power up default, t_{CONV} = 250 ms typical)

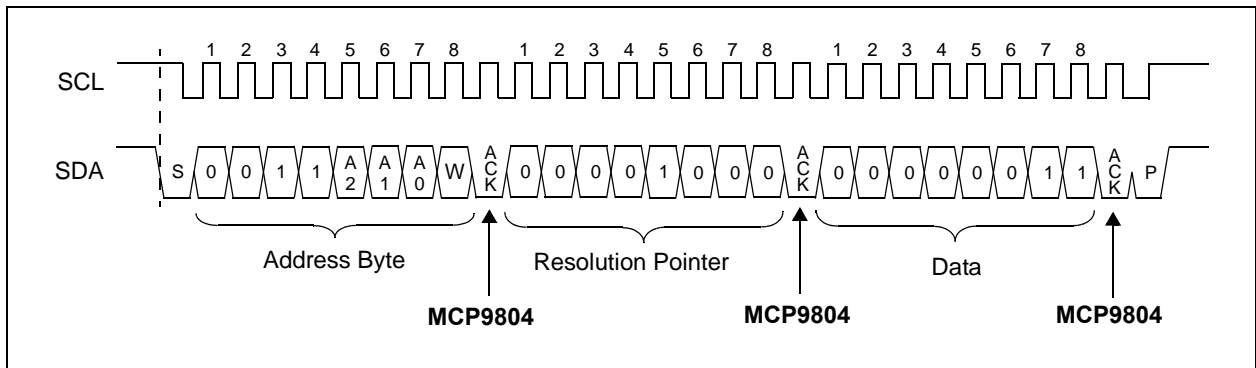

FIGURE 5-9: Timing Diagram for Changing T_A Resolution to 0.0625°C `<0000 0011>b` (See **Section 4.0**).

MCP9804

5.2 SENSOR FEATURE DESCRIPTION

5.2.1 SHUTDOWN MODE

Shutdown mode disables all power-consuming activities (including temperature sampling operations) while leaving the serial interface active. This mode is selected by setting bit 8 of CONFIG to '1'. In this mode, the device consumes I_{SHDN} . It remains in this mode until bit 8 is cleared '0' to enable Continuous Conversion mode, or until power is recycled.

The Shutdown bit (bit 8) cannot be set to '1' while bits 6 and 7 of CONFIG (Lock bits) are set to '1'. However, it can be cleared '0' or returned to Continuous Conversion while locked.

In Shutdown mode, all registers can be read or written. However, the serial bus activity increases the shutdown current. In addition, if the device is in shutdown while the Alert pin is asserted, the device will retain the active state during shutdown. This increases the shutdown current due to the additional Alert output current.

5.2.2 TEMPERATURE HYSTERESIS (T_{HYST})

A hysteresis of 0°C, 1.5°C, 3°C or 6°C can be selected for the T_{UPPER} , T_{LOWER} and T_{CRIT} temperature boundaries using bits 10 and 9 of CONFIG. The hysteresis applies for decreasing temperature only (hot to cold), or as temperature drifts below the specified limit.

The hysteresis bits can not be changed if either of the lock bits, bits 6 and 7 of CONFIG, are set to '1'.

The T_{UPPER} , T_{LOWER} and T_{CRIT} boundary conditions are described graphically in [Figure 5-11](#).

5.2.3 ALERT OUTPUT CONFIGURATION

The Alert output can be enabled using bit 3 of CONFIG (Alert output control bit) and can be configured as either a comparator output or as Interrupt Output mode using bit 0 of CONFIG (Alert mode). The polarity can also be specified as an active-high or active-low using bit 1 of CONFIG (Alert polarity). This is an open drain output and requires a pull-up resistor.

When the ambient temperature increases above the critical temperature limit, the Alert output is forced to a comparator output (regardless of bit 0 of CONFIG). When the temperature drifts below the critical temperature limit minus hysteresis, the Alert output automatically returns to the state specified by bit 0 of CONFIG.

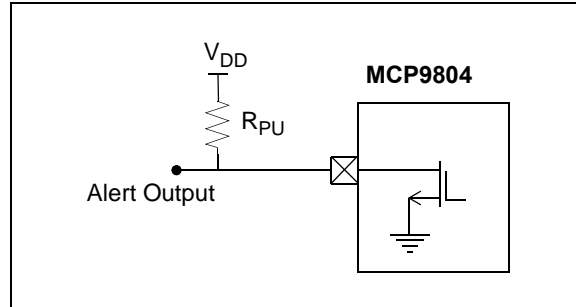

FIGURE 5-10: Active-Low Alert Output Configuration.

The status of the Alert output can be read using bit 4 of CONFIG (Alert status). This bit can not be set to '1' in shutdown mode.

Bit 7 and 6 of the CONFIG register can be used to lock the T_{UPPER} , T_{LOWER} and T_{CRIT} registers. The bits prevent false triggers at the Alert output due to an accidental rewrite to these registers.

The Alert output can also be used as a critical temperature output using bit 2 of CONFIG (critical output only). When this feature is selected, the Alert output becomes a comparator output. In this mode, the interrupt output configuration (bit 0 of CONFIG) is ignored.

5.2.3.1 Comparator Mode

Comparator mode is selected using bit 0 of CONFIG. In this mode, the Alert output is asserted as active-high or active-low using bit 1 of CONFIG. [Figure 5-11](#) shows the conditions that toggle the Alert output.

If the device enters Shutdown mode with asserted Alert output, the output remains asserted during Shutdown. The device must be operating in Continuous Conversion mode for t_{CONV} ; the T_A vs. T_{UPPER} , T_{LOWER} and T_{CRIT} boundary conditions need to be satisfied in order for the Alert output to deassert.

Comparator mode is useful for thermostat-type applications, such as turning on a cooling fan or triggering a system shutdown when the temperature exceeds a safe operating range.

5.2.3.2 Interrupt Mode

In the Interrupt mode, the Alert output is asserted as active-high or active-low (depending on the polarity configuration) when T_A drifts above or below T_{UPPER} and T_{LOWER} limits. The output is deasserted by setting bit 5 (Interrupt Clear) of CONFIG. Shutting down the device will not reset or deassert the Alert output. This mode can not be selected when the Alert output is used as critical temperature output only, using bit 2 of CONFIG.

This mode is designed for interrupt driven microcontroller based systems. The microcontroller receiving the interrupt will have to acknowledge the interrupt by setting bit 5 of CONFIG register from the MCP9804.

5.2.4 TEMPERATURE RESOLUTION

The MCP9804 is capable of providing a temperature data with 0.5°C to 0.0625°C resolution. The Resolution can be selected using the Resolution register ([Register 5-7](#)) which is located in address '00001000'b. It provides measurement flexibility. A 0.0625°C resolution is set as POR default by factory.

TABLE 5-2: TEMPERATURE CONVERSION TIME

Resolution	t _{CONV} (ms)	Samples/sec (typical)
0.5°C	30	33
0.25°C	65	15
0.125°C	130	7
0.0625°C (Power-up default)	250	4

MCP9804

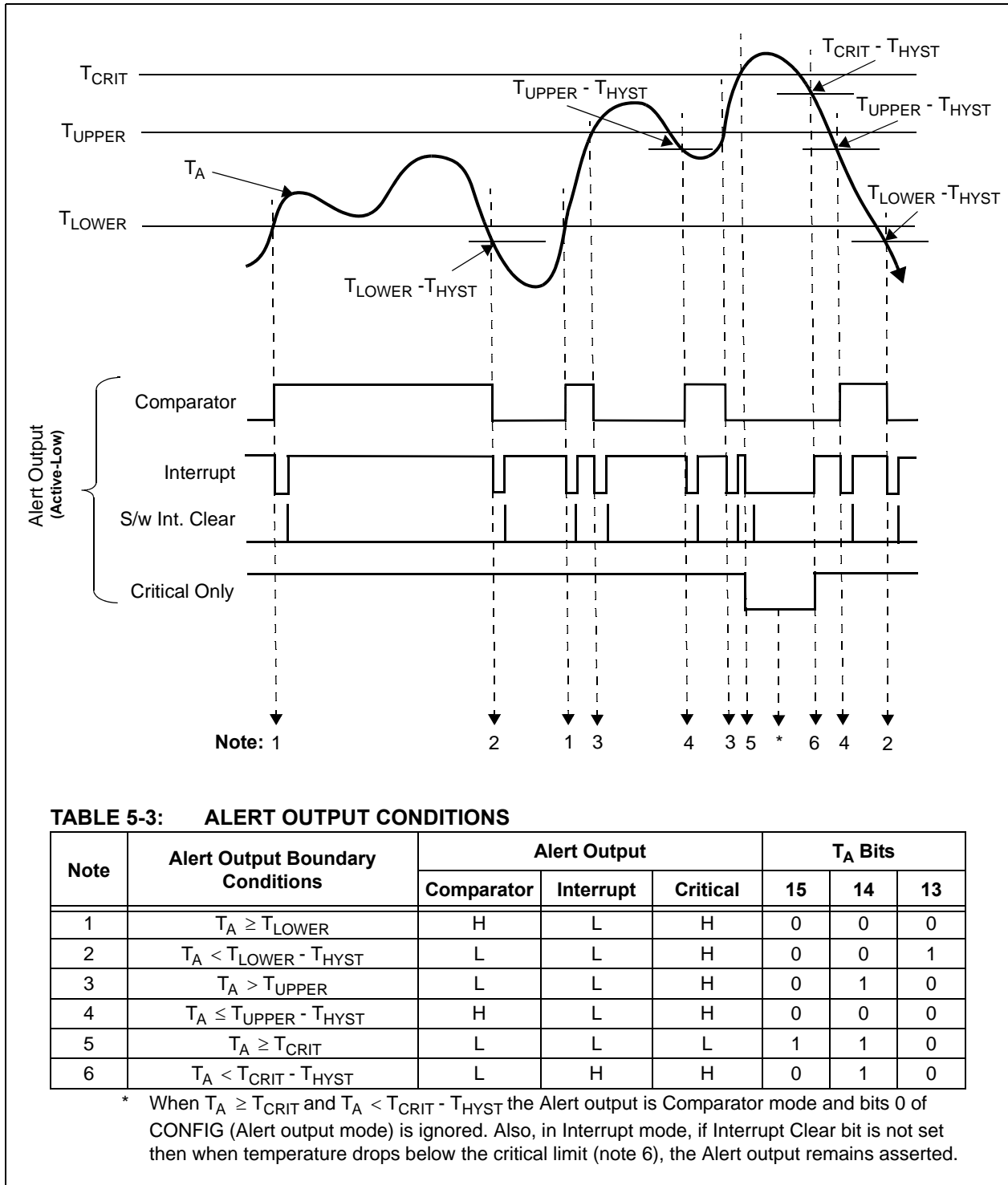

FIGURE 5-11: Alert Output Condition.

5.3 Summary of Power-on Default

The MCP9804 has an internal Power-on Reset (POR) circuit. If the power supply voltage V_{DD} glitches below the V_{POR} threshold, the device resets the registers to the power-on default settings.

Table 5-4 shows the power-on default summary for the temperature sensor registers.

TABLE 5-4: POWER-ON RESET DEFAULTS

Registers		Default Register Data (Hexadecimal)	Power-up Default Register Description
Address (Hexadecimal)	Register Name		
0x01	CONFIG	0x0000	Comparator mode Active-Low output Alert and critical output Output disabled Alert not asserted Interrupt cleared Alert limits unlocked Critical limit unlocked Continuous conversion 0°C Hysteresis
0x02	T_{UPPER}	0x0000	0°C
0x03	T_{LOWER}	0x0000	0°C
0x04	T_{CRIT}	0x0000	0°C
0x05	T_A	0x0000	0°C
0x06	Manufacturer ID	0x0054	0x0054 (hex)
0x07	Device ID/ Device Revision	0x0200	0x0200 (hex)
0x08	Resolution	0x03	0x03 (hex)

MCP9804

NOTES:

6.0 APPLICATIONS INFORMATION

6.1 Layout Considerations

The MCP9804 does not require any additional components besides the master controller in order to measure temperature. However, it is recommended that a decoupling capacitor of 0.1 μF to 1 μF be used between the V_{DD} and GND pins. A high-frequency ceramic capacitor is recommended. It is necessary for the capacitor to be located as close as possible to the power and ground pins of the device in order to provide effective noise protection.

In addition, good PCB layout is key for better thermal conduction from the PCB temperature to the sensor die. For good temperature sensitivity, add a ground layer under the device pins as shown in [Figure 6-1](#).

6.2 Thermal Considerations

A potential for self-heating errors can exist if the MCP9804 SDA, SCL and Event lines are heavily loaded with pull-ups (high current). Typically, the self-heating error is negligible because of the relatively small current consumption of the MCP9804. A temperature accuracy error of approximately 0.5°C could result from self-heating if the communication pins sink/source the maximum current specified.

For example, if the Event output is loaded to maximum I_{OL} , [Equation 6-1](#) can be used to determine the effect of self-heating.

EQUATION 6-1: EFFECT OF SELF-HEATING

$$T_{\Delta} = \theta_{\text{JA}}(V_{\text{DD}} \cdot I_{\text{DD}} + V_{\text{OL_Alert}} \cdot I_{\text{OL_Alert}} + V_{\text{OL_SDA}} \cdot I_{\text{OL_SDA}})$$

Where:

$$T_{\Delta} = T_{\text{J}} - T_{\text{A}}$$

T_{J} = Junction Temperature

T_{A} = Ambient Temperature

θ_{JA} = Package Thermal Resistance

$V_{\text{OL_Alert, SDA}}$ = Alert and SDA Output V_{OL}
(0.4 V_{max})

$I_{\text{OL_Alert, SDA}}$ = Alert and SDA Output I_{OL}
(3 mA_{max})

At room temperature ($T_{\text{A}} = +25^{\circ}\text{C}$) with maximum $I_{\text{DD}} = 500 \mu\text{A}$ and $V_{\text{DD}} = 3.6\text{V}$, the self-heating due to power dissipation T_{Δ} is 0.2°C for the DFN-8 package and 0.5°C for the TSSOP-8 package.

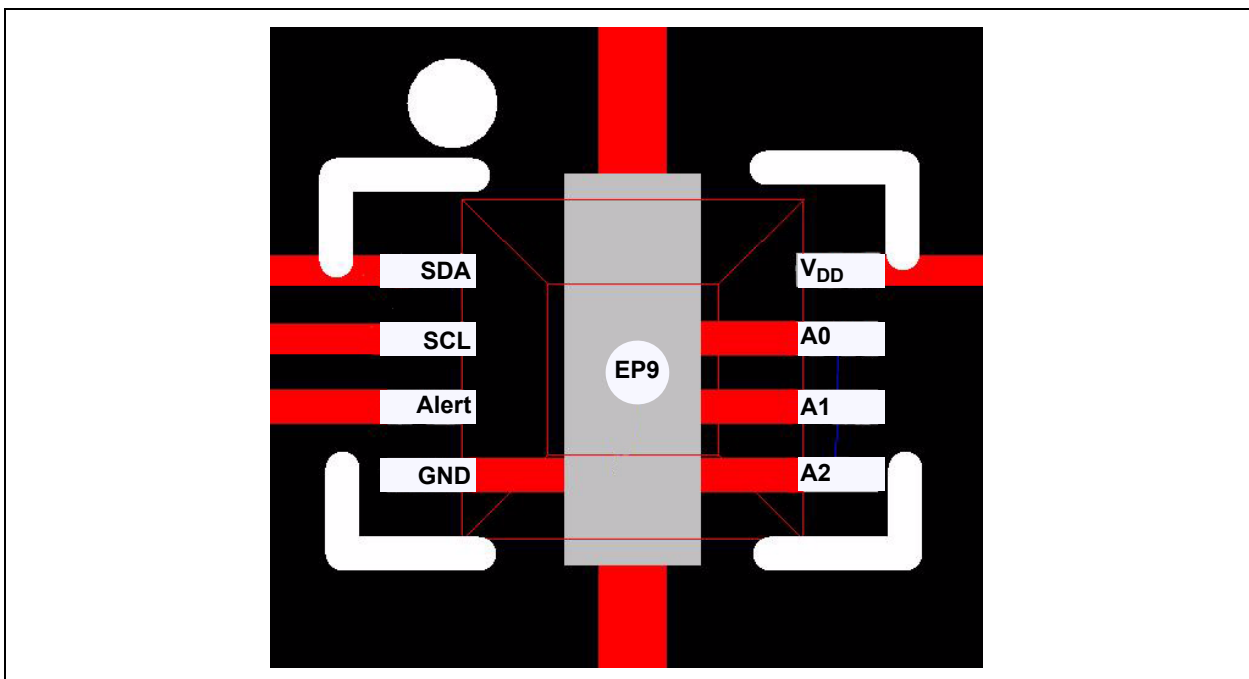

FIGURE 6-1: DFN Package Layout (Top View).

MCP9804

NOTES:

7.0 PACKAGING INFORMATION

7.1 Package Marking Information

8-Lead DFN (2 x 3)

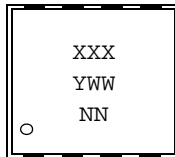

Example:

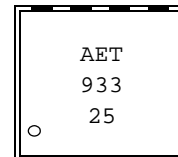

8-Lead MSOP

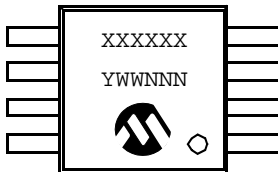

Example:



Legend:	XX...X	Customer-specific information
	Y	Year code (last digit of calendar year)
	YY	Year code (last 2 digits of calendar year)
	WW	Week code (week of January 1 is week '01')
	NNN	Alphanumeric traceability code
	(e3)	Pb-free JEDEC designator for Matte Tin (Sn)
	*	This package is Pb-free. The Pb-free JEDEC designator (e3) can be found on the outer packaging for this package.

Note: In the event the full Microchip part number cannot be marked on one line, it will be carried over to the next line, thus limiting the number of available characters for customer-specific information.

MCP9804

8-Lead Plastic Dual Flat, No Lead Package (MC) – 2x3x0.9 mm Body [DFN]

Note: For the most current package drawings, please see the Microchip Packaging Specification located at <http://www.microchip.com/packaging>

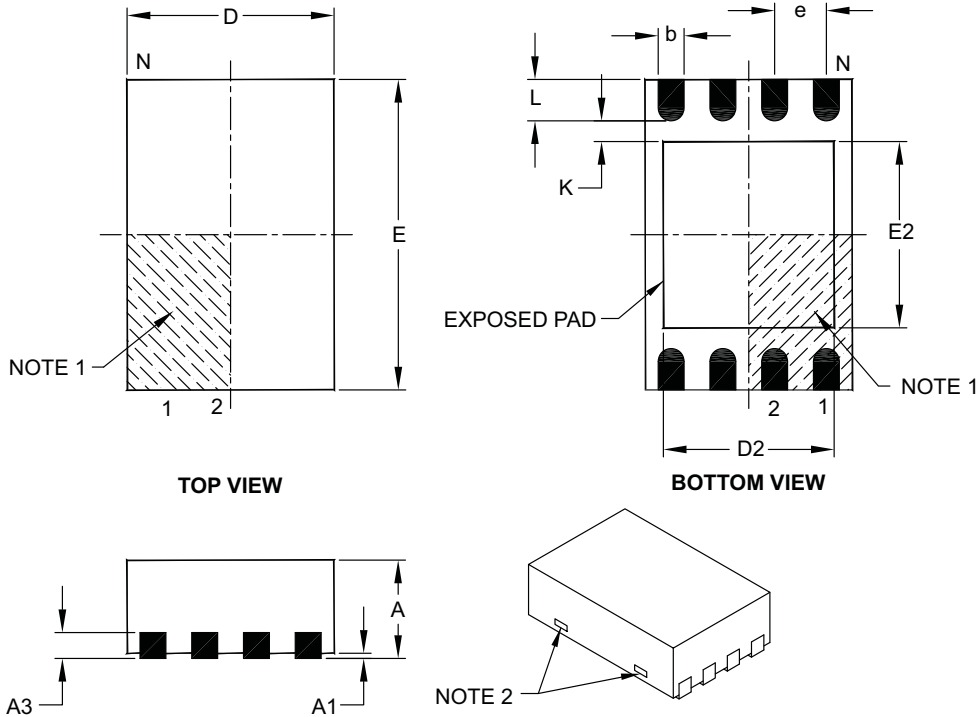

Dimension Limits	Units	MILLIMETERS		
		MIN	NOM	MAX
Number of Pins	N	8		
Pitch	e	0.50 BSC		
Overall Height	A	0.80	0.90	1.00
Standoff	A1	0.00	0.02	0.05
Contact Thickness	A3	0.20 REF		
Overall Length	D	2.00 BSC		
Overall Width	E	3.00 BSC		
Exposed Pad Length	D2	1.30	–	1.55
Exposed Pad Width	E2	1.50	–	1.75
Contact Width	b	0.20	0.25	0.30
Contact Length	L	0.30	0.40	0.50
Contact-to-Exposed Pad	K	0.20	–	–

Notes:

- Pin 1 visual index feature may vary, but must be located within the hatched area.
- Package may have one or more exposed tie bars at ends.
- Package is saw singulated.
- Dimensioning and tolerancing per ASME Y14.5M.

BSC: Basic Dimension. Theoretically exact value shown without tolerances.

REF: Reference Dimension, usually without tolerance, for information purposes only.

Microchip Technology Drawing C04-123C

8-Lead Plastic Dual Flat, No Lead Package (MC) – 2x3x0.9 mm Body [DFN]

Note: For the most current package drawings, please see the Microchip Packaging Specification located at <http://www.microchip.com/packaging>

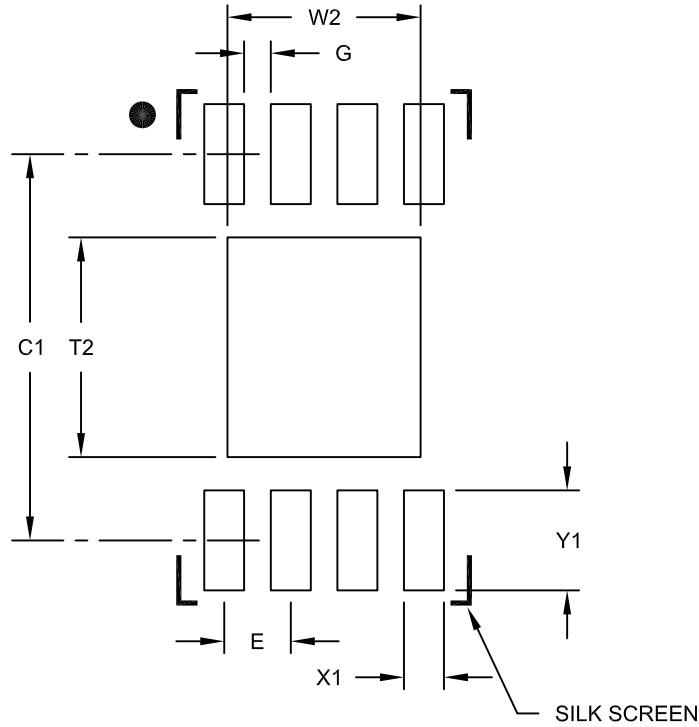

RECOMMENDED LAND PATTERN

Dimension Limits	Units	MILLIMETERS		
		MIN	NOM	MAX
Contact Pitch	E	0.50 BSC		
Optional Center Pad Width	W2			1.45
Optional Center Pad Length	T2			1.75
Contact Pad Spacing	C1		2.90	
Contact Pad Width (X8)	X1			0.30
Contact Pad Length (X8)	Y1			0.75
Distance Between Pads	G	0.20		

Notes:

1. Dimensioning and tolerancing per ASME Y14.5M

BSC: Basic Dimension. Theoretically exact value shown without tolerances.

Microchip Technology Drawing No. C04-2123A

MCP9804

8-Lead Plastic Micro Small Outline Package (MS) [MSOP]

Note: For the most current package drawings, please see the Microchip Packaging Specification located at <http://www.microchip.com/packaging>

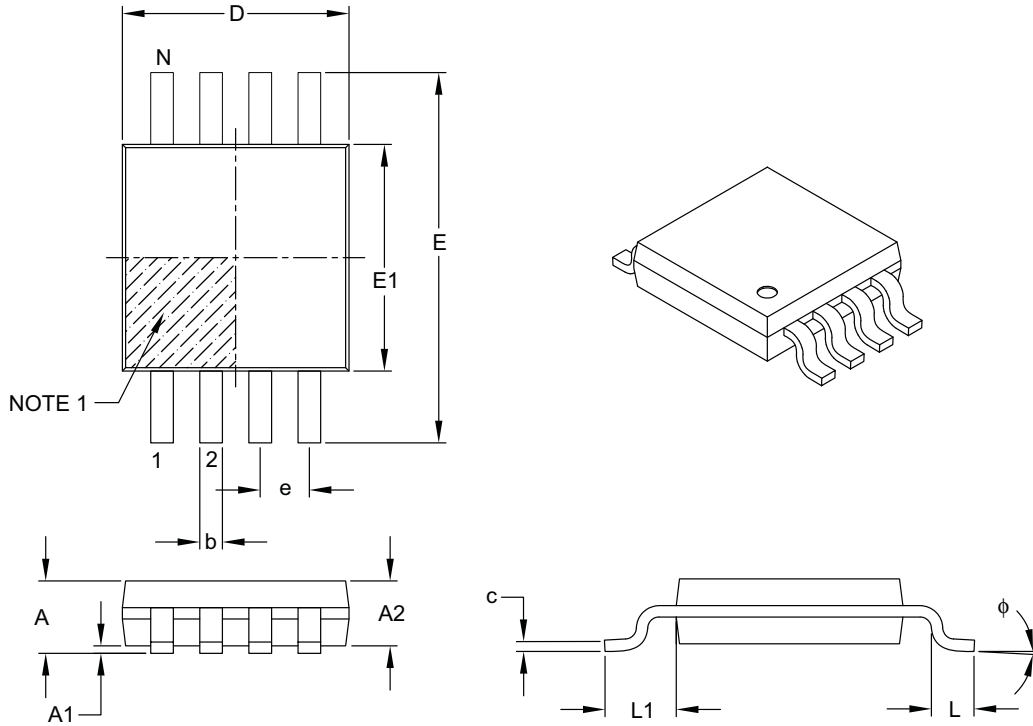

Dimension Limits	Units	MILLIMETERS		
		MIN	NOM	MAX
Number of Pins	N	8		
Pitch	e	0.65 BSC		
Overall Height	A	–	–	1.10
Molded Package Thickness	A2	0.75	0.85	0.95
Standoff	A1	0.00	–	0.15
Overall Width	E	4.90 BSC		
Molded Package Width	E1	3.00 BSC		
Overall Length	D	3.00 BSC		
Foot Length	L	0.40	0.60	0.80
Footprint	L1	0.95 REF		
Foot Angle	ϕ	0°	–	8°
Lead Thickness	c	0.08	–	0.23
Lead Width	b	0.22	–	0.40

Notes:

- Pin 1 visual index feature may vary, but must be located within the hatched area.
- Dimensions D and E1 do not include mold flash or protrusions. Mold flash or protrusions shall not exceed 0.15 mm per side.
- Dimensioning and tolerancing per ASME Y14.5M.

BSC: Basic Dimension. Theoretically exact value shown without tolerances.

REF: Reference Dimension, usually without tolerance, for information purposes only.

Microchip Technology Drawing C04-111B

8-Lead Plastic Micro Small Outline Package (MS) [MSOP]

Note: For the most current package drawings, please see the Microchip Packaging Specification located at <http://www.microchip.com/packaging>

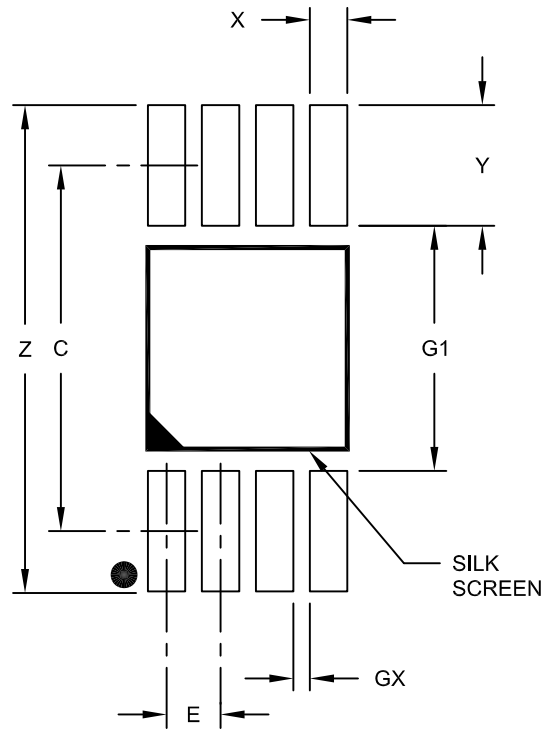

RECOMMENDED LAND PATTERN

Dimension Limits	Units	MILLIMETERS		
		MIN	NOM	MAX
Contact Pitch	E	0.65 BSC		
Contact Pad Spacing	C		4.40	
Overall Width	Z			5.85
Contact Pad Width (X8)	X1			0.45
Contact Pad Length (X8)	Y1			1.45
Distance Between Pads	G1	2.95		
Distance Between Pads	GX	0.20		

Notes:

1. Dimensioning and tolerancing per ASME Y14.5M

BSC: Basic Dimension. Theoretically exact value shown without tolerances.

Microchip Technology Drawing No. C04-2111A

MCP9804

NOTES:

Software License Agreement

The software supplied herewith by Microchip Technology Incorporated (the "Company") is intended and supplied to you, the Company's customer, for use solely and exclusively with products manufactured by the Company.

The software is owned by the Company and/or its supplier, and is protected under applicable copyright laws. All rights are reserved. Any use in violation of the foregoing restrictions may subject the user to criminal sanctions under applicable laws, as well as to civil liability for the breach of the terms and conditions of this license.

THIS SOFTWARE IS PROVIDED IN AN "AS IS" CONDITION. NO WARRANTIES, WHETHER EXPRESS, IMPLIED OR STATUTORY, INCLUDING, BUT NOT LIMITED TO, IMPLIED WARRANTIES OF MERCHANTABILITY AND FITNESS FOR A PARTICULAR PURPOSE APPLY TO THIS SOFTWARE. THE COMPANY SHALL NOT, IN ANY CIRCUMSTANCES, BE LIABLE FOR SPECIAL, INCIDENTAL OR CONSEQUENTIAL DAMAGES, FOR ANY REASON WHATSOEVER.

APPENDIX A: SOURCE CODE

```

/*****
FileName:      I2C.h
Dependencies:  I2C.c
Processor: PIC18 Microcontrollers
Compiler:  Microchip C18 (for PIC18) or C30 (for PIC24)
Company: Microchip Technology, Inc.

Software License Agreement:

The software supplied herewith by Microchip Technology Incorporated
(the "Company") for its PIC® Microcontroller is intended and
supplied to you, the Company's customer, for use solely and
exclusively on Microchip PIC Microcontroller products. The
software is owned by the Company and/or its supplier, and is
protected under applicable copyright laws. All rights are reserved.
Any use in violation of the foregoing restrictions may subject the
user to criminal sanctions under applicable laws, as well as to
civil liability for the breach of the terms and conditions of this
license.

THIS SOFTWARE IS PROVIDED IN AN "AS IS" CONDITION. NO WARRANTIES,
WHETHER EXPRESS, IMPLIED OR STATUTORY, INCLUDING, BUT NOT LIMITED
TO, IMPLIED WARRANTIES OF MERCHANTABILITY AND FITNESS FOR A
PARTICULAR PURPOSE APPLY TO THIS SOFTWARE. THE COMPANY SHALL NOT,
IN ANY CIRCUMSTANCES, BE LIABLE FOR SPECIAL, INCIDENTAL OR
CONSEQUENTIAL DAMAGES, FOR ANY REASON WHATSOEVER.

*****/

#define ACK 1
#define NACK 0

#define SLAVE_7 6 /* I2C Slave mode, 7-bit address */
#define SLAVE_10 7 /* I2C Slave mode, 10-bit address */
#define MASTER 8 /* I2C Master mode */

/* SSPSTAT REGISTER */
#define SLEW_OFF 0xC0 /* Slew rate disabled for 100kHz mode */
#define SLEW_ON 0x00 /* Slew rate enabled for 400kHz mode */

extern void OpenI2C(unsigned char sync_mode, unsigned char slew);
extern void I2CStart(void);
extern void I2CReStart(void);
extern void I2CStop(void);
extern unsigned char WriteI2C(unsigned char data_out);
extern unsigned char ReadI2C(unsigned char ACK);
extern void ACKI2C(void);
extern void nACK(void);
extern void WaitForACK(void);
extern unsigned char I2CDataReady(void);

```

MCP9804

```
/*
FileName:      I2C.c
Dependencies:  I2C.h
Processor: PIC18 Microcontrollers
Compiler:  Microchip C18 (for PIC18) or C30 (for PIC24)
Company: Microchip Technology, Inc.
*/
```

Software License Agreement:

The software supplied herewith by Microchip Technology Incorporated (the "Company") for its PIC® Microcontroller is intended and supplied to you, the Company's customer, for use solely and exclusively on Microchip PIC Microcontroller products. The software is owned by the Company and/or its supplier, and is protected under applicable copyright laws. All rights are reserved. Any use in violation of the foregoing restrictions may subject the user to criminal sanctions under applicable laws, as well as to civil liability for the breach of the terms and conditions of this license.

THIS SOFTWARE IS PROVIDED IN AN "AS IS" CONDITION. NO WARRANTIES, WHETHER EXPRESS, IMPLIED OR STATUTORY, INCLUDING, BUT NOT LIMITED TO, IMPLIED WARRANTIES OF MERCHANTABILITY AND FITNESS FOR A PARTICULAR PURPOSE APPLY TO THIS SOFTWARE. THE COMPANY SHALL NOT, IN ANY CIRCUMSTANCES, BE LIABLE FOR SPECIAL, INCIDENTAL OR CONSEQUENTIAL DAMAGES, FOR ANY REASON WHATSOEVER.

```
/*
*****/

#include "p18f2550.h" // This code is developed for PIC18F2550
//It can be modified to be used with any PICmicro with MSSP module

#include "I2C.h"

/*
*****
*   Function Name:  OpenI2C1
*   Return Value:   void
*   Parameters:     SSP1 peripheral setup bytes
*   Description:    This function sets up the SSP1 module on a
*                   PIC18CXXX device for use with a Microchip I2C
*                   EEPROM device or I2C bus device.
*****/
void OpenI2C(unsigned char sync_mode, unsigned char slew)
{
    SSPSTAT &= 0x3F;           // power on state
    SSPCON1 = 0x00;           // power on state
    SSPCON2 = 0x00;           // power on state
    SSPCON1 |= sync_mode;     // select serial mode
    SSPSTAT |= slew;          // slew rate on/off

    SSPCON1bits.SSPEN = 1;    // enable synchronous serial port
}

/*
*****
*   Function Name:  I2CStart
*   Return Value:   void
*   Parameters:     void
*   Description:    *
*****/
void I2CStart(void)
{
    PIR1bits.SSPIF = 0; //Clear Interrupt
    SSPCON2bits.SEN=1;
    while(!PIR1bits.SSPIF); //Wait for data received Interrupt
    PIR1bits.SSPIF = 0; //Clear Interrupt
}
*/
```

```

/*****
*   Function Name:      I2CReStart
*   Return Value:      void
*   Parameters:        void
*   Description:
*
*****/
void I2CReStart(void)
{
    PIR1bits.SSPIF = 0;//Clear Interrupt
    SSPCON2bits.RSEN = 1;
    while(!PIR1bits.SSPIF);//Wait for data received Interrupt
    PIR1bits.SSPIF = 0;//Clear Interrupt
}

/*****
*   Function Name:      I2CStop
*   Return Value:      void
*   Parameters:        void
*   Description:      Stop bit
*
*****/
void I2CStop(void)
{
    PIR1bits.SSPIF = 0;//Clear Interrupt
    if (!SSPSTATbits.P)
    {
        SSPCON2bits.PEN = 1; //Stop condition
        while(SSPCON2bits.PEN); //wait for STOP
        if (PIR2bits.BCLIF)
            PIR2bits.BCLIF = 0;
        while(!PIR1bits.SSPIF); //Wait for flag to set
        PIR1bits.SSPIF = 0;
    }
}

/*****
*   Function Name:      WriteI2C2
*   Return Value:      Status byte for WCOL detection.
*   Parameters:        Single data byte for I2C2 bus.
*   Description:      This routine writes a single byte to the
*                   I2C2 bus.
*****/
unsigned char WriteI2C( unsigned char data_out )
{
    SSPBUF = data_out;           // write single byte to SSP2BUF
    if ( SSPCON1bits.WCOL )     // test if write collision occurred
        return ( -1 );         // if WCOL bit is set return negative #
    else
    {
        while( SSPSTATbits.BF ); // wait until write cycle is complete
        WaitForACK();//wait for ACK from device
        return ( 0 );           // if WCOL bit is not set return non-negative #
    }
}

```

MCP9804

```

/*****
 *   Function Name:      ReadI2C2
 *   Return Value:      contents of SSP2BUF register
 *   Parameters:        ACK = 1 and NAK = 0
 *   Description:       Read a byte from I2C bus and ACK/NAK
 *****/
unsigned char ReadI2C(unsigned char ACK)
{
    while (SSPSTATbits.BF);
    SSPCON2bits.RCEN = 1;          // enable master for 1 byte reception
    while (!SSPSTATbits.BF);      // wait until byte received
    if ACK                          //
        ACKI2C();                 // Give ACK
    else
        nACK();
    return (SSPBUF);              // return with read byte
}

/*****
 *   Function Name:      AckI2C
 *   Return Value:      void
 *   Parameters:        void
 *   Description:       Initiate ACK bus condition.
 *****/
void ACKI2C(void)
{
    PIR1bits.SSPIF = 0;
    SSPCON2bits.ACKDT = 0;        // set acknowledge bit state for ACK
    SSPCON2bits.ACKEN = 1;       // initiate bus acknowledge sequence
    while(!PIR1bits.SSPIF);
    PIR1bits.SSPIF = 0;
}

/*****
 *   Function Name:      nACKI2C
 *   Return Value:      void
 *   Parameters:        void
 *   Description:       Initiate no-ACK bus condition.
 *****/
void nACK(void)
{
    PIR1bits.SSPIF = 0;
    SSPCON2bits.ACKDT = NACK;    //Disable ACK
    SSPCON2bits.ACKEN = 1;       //Start ACK sequence
    while(!PIR1bits.SSPIF);     //Wait for flag to set
    PIR1bits.SSPIF = 0;
}

/*****
 *   Function Name:      WaitForACK
 *   Return Value:      void
 *   Parameters:        void
 *   Description:
 *****/
void WaitForACK(void)
{
    PIR1bits.SSPIF = 0;          //Clear Interrupt
    while(!PIR1bits.SSPIF);     //Wait for data received Interrupt
    PIR1bits.SSPIF = 0;         //Clear Interrupt
}

```

```
/******  
*      Function Name:      I2CDataReady      *  
*      Return Value:      Buffer Full (BF) flag *  
*      Parameters:        void              *  
*      Description:       Checks if data is in the SSPBUF *  
*****/  
unsigned char I2CDataReady(void)  
{  
    if (SSPSTATbits.BF)          // test if buffer full bit is set  
        return ( +1 );          // data in SSP2BUF register  
    else  
        return ( 0 );           // no data in SSP2BUF register  
}
```

MCP9804

NOTES:

APPENDIX B: REVISION HISTORY

Revision A (September 2009)

- Original Release of this Document.

MCP9804

NOTES:

PRODUCT IDENTIFICATION SYSTEM

To order or obtain information, e.g., on pricing or delivery, refer to the factory or the listed sales office.

<u>PART NO.</u>	<u>X</u>	<u>-X</u>	<u>/XX</u>
Device	Tape and Reel and/or Alternate Pinout	Temperature Range	Package
Device:	MCP9804: Digital Temperature Sensor MCP9804T: Digital Temperature Sensor (Tape and Reel)		
Temperature Range:	E = -40° C to +125° C		
Package:	MC = Plastic Dual Flat No-Lead (DFN) 2x3, 8-lead MS = Plastic Micro Small Outline (MSOP), 8-lead		

Examples:

- a) MCP9804-E/MC: Extended Temperature 8LD DFN package.
- b) MCP9804-E/MS: Extended Temperature 8LD MSOP package.
- c) MCP9804T-E/MC: Tape and Reel, Extended Temperature 8LD DFN package.
- d) MCP9804T-E/MS: Tape and Reel, Extended Temperature 8LD MSOP package.

MCP9804

NOTES:

Note the following details of the code protection feature on Microchip devices:

- Microchip products meet the specification contained in their particular Microchip Data Sheet.
- Microchip believes that its family of products is one of the most secure families of its kind on the market today, when used in the intended manner and under normal conditions.
- There are dishonest and possibly illegal methods used to breach the code protection feature. All of these methods, to our knowledge, require using the Microchip products in a manner outside the operating specifications contained in Microchip's Data Sheets. Most likely, the person doing so is engaged in theft of intellectual property.
- Microchip is willing to work with the customer who is concerned about the integrity of their code.
- Neither Microchip nor any other semiconductor manufacturer can guarantee the security of their code. Code protection does not mean that we are guaranteeing the product as "unbreakable."

Code protection is constantly evolving. We at Microchip are committed to continuously improving the code protection features of our products. Attempts to break Microchip's code protection feature may be a violation of the Digital Millennium Copyright Act. If such acts allow unauthorized access to your software or other copyrighted work, you may have a right to sue for relief under that Act.

Information contained in this publication regarding device applications and the like is provided only for your convenience and may be superseded by updates. It is your responsibility to ensure that your application meets with your specifications. MICROCHIP MAKES NO REPRESENTATIONS OR WARRANTIES OF ANY KIND WHETHER EXPRESS OR IMPLIED, WRITTEN OR ORAL, STATUTORY OR OTHERWISE, RELATED TO THE INFORMATION, INCLUDING BUT NOT LIMITED TO ITS CONDITION, QUALITY, PERFORMANCE, MERCHANTABILITY OR FITNESS FOR PURPOSE. Microchip disclaims all liability arising from this information and its use. Use of Microchip devices in life support and/or safety applications is entirely at the buyer's risk, and the buyer agrees to defend, indemnify and hold harmless Microchip from any and all damages, claims, suits, or expenses resulting from such use. No licenses are conveyed, implicitly or otherwise, under any Microchip intellectual property rights.

Trademarks

The Microchip name and logo, the Microchip logo, dsPIC, KEELOQ, KEELOQ logo, MPLAB, PIC, PICmicro, PICSTART, rfPIC and UNI/O are registered trademarks of Microchip Technology Incorporated in the U.S.A. and other countries.

FilterLab, Hampshire, HI-TECH C, Linear Active Thermistor, MXDEV, MXLAB, SEEVAL and The Embedded Control Solutions Company are registered trademarks of Microchip Technology Incorporated in the U.S.A.

Analog-for-the-Digital Age, Application Maestro, CodeGuard, dsPICDEM, dsPICDEM.net, dsPICworks, dsSPEAK, ECAN, ECONOMONITOR, FanSense, HI-TIDE, In-Circuit Serial Programming, ICSP, Mindi, MiWi, MPASM, MPLAB Certified logo, MPLIB, MPLINK, mTouch, Octopus, Omniscient Code Generation, PICC, PICC-18, PICDEM, PICDEM.net, PICkit, PICtail, PIC³² logo, REAL ICE, rLAB, Select Mode, Total Endurance, TSHARC, UniWinDriver, WiperLock and ZENA are trademarks of Microchip Technology Incorporated in the U.S.A. and other countries.

SQTP is a service mark of Microchip Technology Incorporated in the U.S.A.

All other trademarks mentioned herein are property of their respective companies.

© 2009, Microchip Technology Incorporated, Printed in the U.S.A., All Rights Reserved.

 Printed on recycled paper.

QUALITY MANAGEMENT SYSTEM
CERTIFIED BY DNV
== ISO/TS 16949:2002 ==

Microchip received ISO/TS-16949:2002 certification for its worldwide headquarters, design and wafer fabrication facilities in Chandler and Tempe, Arizona; Gresham, Oregon and design centers in California and India. The Company's quality system processes and procedures are for its PIC® MCUs and dsPIC® DSCs, KEELOQ® code hopping devices, Serial EEPROMs, microperipherals, nonvolatile memory and analog products. In addition, Microchip's quality system for the design and manufacture of development systems is ISO 9001:2000 certified.



WORLDWIDE SALES AND SERVICE

AMERICAS

Corporate Office
2355 West Chandler Blvd.
Chandler, AZ 85224-6199
Tel: 480-792-7200
Fax: 480-792-7277
Technical Support:
<http://support.microchip.com>
Web Address:
www.microchip.com

Atlanta
Duluth, GA
Tel: 678-957-9614
Fax: 678-957-1455

Boston
Westborough, MA
Tel: 774-760-0087
Fax: 774-760-0088

Chicago
Itasca, IL
Tel: 630-285-0071
Fax: 630-285-0075

Cleveland
Independence, OH
Tel: 216-447-0464
Fax: 216-447-0643

Dallas
Addison, TX
Tel: 972-818-7423
Fax: 972-818-2924

Detroit
Farmington Hills, MI
Tel: 248-538-2250
Fax: 248-538-2260

Kokomo
Kokomo, IN
Tel: 765-864-8360
Fax: 765-864-8387

Los Angeles
Mission Viejo, CA
Tel: 949-462-9523
Fax: 949-462-9608

Santa Clara
Santa Clara, CA
Tel: 408-961-6444
Fax: 408-961-6445

Toronto
Mississauga, Ontario,
Canada
Tel: 905-673-0699
Fax: 905-673-6509

ASIA/PACIFIC

Asia Pacific Office
Suites 3707-14, 37th Floor
Tower 6, The Gateway
Harbour City, Kowloon
Hong Kong
Tel: 852-2401-1200
Fax: 852-2401-3431

Australia - Sydney
Tel: 61-2-9868-6733
Fax: 61-2-9868-6755

China - Beijing
Tel: 86-10-8528-2100
Fax: 86-10-8528-2104

China - Chengdu
Tel: 86-28-8665-5511
Fax: 86-28-8665-7889

China - Hong Kong SAR
Tel: 852-2401-1200
Fax: 852-2401-3431

China - Nanjing
Tel: 86-25-8473-2460
Fax: 86-25-8473-2470

China - Qingdao
Tel: 86-532-8502-7355
Fax: 86-532-8502-7205

China - Shanghai
Tel: 86-21-5407-5533
Fax: 86-21-5407-5066

China - Shenyang
Tel: 86-24-2334-2829
Fax: 86-24-2334-2393

China - Shenzhen
Tel: 86-755-8203-2660
Fax: 86-755-8203-1760

China - Wuhan
Tel: 86-27-5980-5300
Fax: 86-27-5980-5118

China - Xiamen
Tel: 86-592-2388138
Fax: 86-592-2388130

China - Xian
Tel: 86-29-8833-7252
Fax: 86-29-8833-7256

China - Zhuhai
Tel: 86-756-3210040
Fax: 86-756-3210049

ASIA/PACIFIC

India - Bangalore
Tel: 91-80-3090-4444
Fax: 91-80-3090-4080

India - New Delhi
Tel: 91-11-4160-8631
Fax: 91-11-4160-8632

India - Pune
Tel: 91-20-2566-1512
Fax: 91-20-2566-1513

Japan - Yokohama
Tel: 81-45-471- 6166
Fax: 81-45-471-6122

Korea - Daegu
Tel: 82-53-744-4301
Fax: 82-53-744-4302

Korea - Seoul
Tel: 82-2-554-7200
Fax: 82-2-558-5932 or
82-2-558-5934

Malaysia - Kuala Lumpur
Tel: 60-3-6201-9857
Fax: 60-3-6201-9859

Malaysia - Penang
Tel: 60-4-227-8870
Fax: 60-4-227-4068

Philippines - Manila
Tel: 63-2-634-9065
Fax: 63-2-634-9069

Singapore
Tel: 65-6334-8870
Fax: 65-6334-8850

Taiwan - Hsin Chu
Tel: 886-3-6578-300
Fax: 886-3-6578-370

Taiwan - Kaohsiung
Tel: 886-7-536-4818
Fax: 886-7-536-4803

Taiwan - Taipei
Tel: 886-2-2500-6610
Fax: 886-2-2508-0102

Thailand - Bangkok
Tel: 66-2-694-1351
Fax: 66-2-694-1350

EUROPE

Austria - Wels
Tel: 43-7242-2244-39
Fax: 43-7242-2244-393

Denmark - Copenhagen
Tel: 45-4450-2828
Fax: 45-4485-2829

France - Paris
Tel: 33-1-69-53-63-20
Fax: 33-1-69-30-90-79

Germany - Munich
Tel: 49-89-627-144-0
Fax: 49-89-627-144-44

Italy - Milan
Tel: 39-0331-742611
Fax: 39-0331-466781

Netherlands - Drunen
Tel: 31-416-690399
Fax: 31-416-690340

Spain - Madrid
Tel: 34-91-708-08-90
Fax: 34-91-708-08-91

UK - Wokingham
Tel: 44-118-921-5869
Fax: 44-118-921-5820

03/26/09

Mouser Electronics

Authorized Distributor

Click to View Pricing, Inventory, Delivery & Lifecycle Information:

[Microchip:](#)

[MCP9804-E/MS](#) [MCP9804T-E/MS](#)