

SPECIFICATION

FOR APPRONAL

Customer : Quartz1

Product Name : Strobe Light

Model Name : VSL-05-V12

Drawing No. : VS20140227012

Signature of Voice

Approved by	Checkde by	Issued by	Date



福爱斯电子有限公司
VOICE ELECTRONICS CO.,LTD.

Office Add:Haoyangguang B-302# No.968 Baizhang Road,Ningbo China

Factory add: Shishan Industrial Park Moushan Town Yuyao City China

Tel:86-0574-87471601 Fax:86-0574-87471603 P.C.315000

Http://www.nbvoice.com E-mail:sales@nbvoice.com

Specification for Strobe Light

Page

2/5

Model No.: VSL-05-V12

Revision No.

1.0

Drawing No.

VS20140227012

Table of contents

1. Revision
2. Scope
3. General Characteristics
4. Electrical and Acoustic Characteristics.
5. Dimensions
6. Packing

1. Revision

Rev.No	Date	Page	Description of Revision
1.0	2019/1/30		Preliminary

Specification for Strobe Light	Page	3/5
	Revision No.	1.0
Model No. : VSL-05-V12	Drawing No.	VS20140227012

2. Scope

This specification is applied to the siren used for sounder in alarm systems, Please contact us when using this product for any other applications than described in the above.

3. General

- 2.1 Out-Diameter : 100 mm
- 2.2 Height : 77 mm
- 2.3 Weight : 180 ±10g
- 2.4 Operating Temperature range:
-20~+60 °C without loss of function
- 2.5 Store Temperature range:
-30~+70 °C without loss of function

4. Electrical and Acoustic Characteristics.

Test condition : 15 ~ 35 °C, 25% ~ 85% RH, 860~1060 mbar

No	Items	Specification
1	Rated Voltage	12V DC
2	Working Voltage	6-15V DC
3	Max Rated Current	150mA/12VDC
4	Flash Frequency	100±20 Per Minute
5	Operating Life	500 Hours Continuous Duty At 12VDC
6	Case Material/Color	ABS/Black
7	Lens Material/Color	Acrylic/Red
8	Wires Connection	Red +12VDC、 Black GND
9	Strobe Source	Xenon Tube/LEDS

Specification for Strobe Light

Page

4/5

Revision No.

1.0

Model No. : VSL-05-V12

Drawing No.

VS20140227012

5. Dimensions

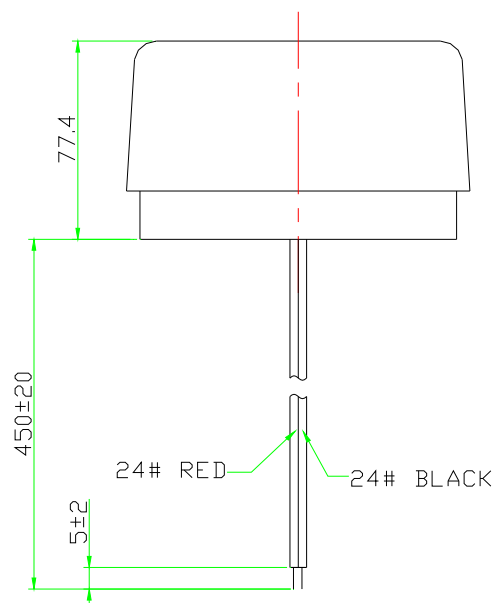
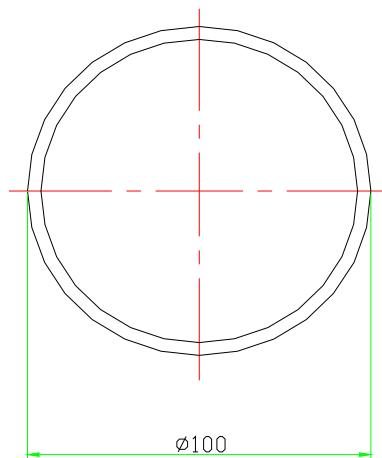

FIRST ANGLE PROJECTION



UNIT : mm

Tolerance : ± 1.5

Specification for Strobe Light	Page	5/5
	Revision No.	1.0
Model No. : VSL-05-V12	Drawing No.	VS20140227012

6. Packing

Each minimum package unit of products shall be in a carton box and it shall be marked with Part Number ,quantity .There shall be no mechanical damage on products during transportation and/or in storage.

G.W./N.W.:12/11KGS
Total:60 pcs per box
Size:56X23.5X58.5CM