

WAGO → I/O → SYSTEM 750

Modular I/O-System

ETHERNET TCP/IP

750-342



Manual

Technical description,
installation and
configuration

Version 2.1.1

Copyright © 2007 by WAGO Kontakttechnik GmbH & Co. KG
All rights reserved.

WAGO Kontakttechnik GmbH & Co. KG

Hansastraße 27
D-32423 Minden

Phone: +49 (0) 571/8 87 – 0
Fax: +49 (0) 571/8 87 – 1 69
E-Mail: info@wago.com
Web: <http://www.wago.com>

Technical Support

Phone: +49 (0) 571/8 87 – 5 55
Fax: +49 (0) 571/8 87 – 85 55
E-Mail: support@wago.com

Every conceivable measure has been taken to ensure the correctness and completeness of this documentation. However, as errors can never be fully excluded we would appreciate any information or ideas at any time.

E-Mail: documentation@wago.com

We wish to point out that the software and hardware terms as well as the trademarks of companies used and/or mentioned in the present manual are generally trademark or patent protected.

This product includes software developed by the University of California, Berkley and ist contributors.

TABLE OF CONTENTS

1	Important Notes	1
1.1	Legal Principles	1
1.1.1	Copyright	1
1.1.2	Personnel Qualification	1
1.1.3	Conforming Use of Series 750	2
1.1.4	Technical Condition of the Devices	2
1.2	Standards and Regulations for Operating the 750 Series	2
1.3	Symbols	3
1.4	Safety Information.....	4
1.5	Font Conventions	5
1.6	Number Notation	5
1.7	Scope	1
1.8	Important Comments for Starting up.....	5
1.9	Abbreviation.....	6
2	The WAGO-I/O-SYSTEM 750	7
2.1	System Description.....	7
2.2	Technical Data.....	8
2.3	Manufacturing Number	14
2.4	Component Update.....	15
2.5	Storage, Assembly and Transport	15
2.6	Mechanical Setup	16
2.6.1	Installation Position	16
2.6.2	Total Expansion.....	16
2.6.3	Assembly onto Carrier Rail	17
2.6.3.1	Carrier rail properties.....	17
2.6.3.2	WAGO DIN Rail	18
2.6.4	Spacing	18
2.6.5	Plugging and Removal of the Components	19
2.6.6	Assembly Sequence	20
2.6.7	Internal Bus/Data Contacts.....	21
2.6.8	Power Contacts	22
2.6.9	Wire connection.....	23
2.7	Power Supply	24
2.7.1	Isolation	24
2.7.2	System Supply	25
2.7.2.1	Connection	25
2.7.2.2	Alignment	26
2.7.3	Field Supply.....	28
2.7.3.1	Connection	28
2.7.3.2	Fusing.....	29
2.7.4	Supplementary power supply regulations.....	32
2.7.5	Supply example	33
2.7.6	Power Supply Unit.....	34
2.8	Grounding.....	35
2.8.1	Grounding the DIN Rail	35
2.8.1.1	Framework Assembly	35

2.8.1.2	Insulated Assembly	35
2.8.2	Grounding Function	36
2.8.3	Grounding Protection	37
2.9	Shielding (Screening)	38
2.9.1	General.....	38
2.9.2	Bus Conductors.....	38
2.9.3	Signal Conductors.....	38
2.9.4	WAGO Shield (Screen) Connecting System.....	39
2.10	Assembly Guidelines/Standards	39
3	Fieldbus Coupler	40
3.1	Fieldbus coupler 750-342	40
3.1.1	Description.....	40
3.1.2	Hardware.....	41
3.1.2.1	View	41
3.1.2.2	Device supply.....	42
3.1.2.3	Fieldbus connection	42
3.1.2.4	Display elements	43
3.1.2.5	Configuration interface	43
3.1.2.6	Hardware address (MAC-ID)	44
3.1.3	Operating system	44
3.1.4	Process image	45
3.1.4.1	Example of a process input image	46
3.1.4.2	Example of a process output image	47
3.1.4.3	Process Data Architecture	48
3.1.5	Data Exchange	48
3.1.5.1	Memory areas.....	49
3.1.5.2	Addressing	50
3.1.5.2.1	Addressing the I/O modules.....	50
3.1.5.3	Data exchange between MODBUS/TCP master and I/O modules.....	51
3.1.6	Starting up a Fieldbus Node	52
3.1.6.1	Note the MAC-ID and establish the fieldbus node.....	52
3.1.6.2	Connecting PC and fieldbus node.....	52
3.1.6.3	Determining IP addresses	53
3.1.6.4	Allocating the IP address to the fieldbus node	53
3.1.6.5	Testing the function of the fieldbus node	56
3.1.6.6	Reading out the information as HTML pages.....	57
3.1.7	LED Display	58
3.1.7.1	Fieldbus status.....	58
3.1.7.2	Node status – Blink code from the 'I/O' LED	59
3.1.7.3	Supply voltage status	66
3.1.8	Fault behavior	66
3.1.8.1	Fieldbus failure	66
3.1.8.2	Internal bus fault	66
3.1.9	Technical Data	67
4	Fieldbus Communication.....	69
4.1	ETHERNET	69
4.1.1	General.....	69

4.1.2	Network Architecture – Principles and Regulations	70
4.1.2.1	Transmission Media.....	71
4.1.2.2	Network Topologies.....	73
4.1.2.3	Coupler Modules.....	76
4.1.2.4	Important Terms.....	77
4.1.3	Network Communication.....	79
4.1.3.1	Protocol layer model.....	79
4.1.3.2	Communication Protocols.....	81
4.1.3.2.1	ETHERNET	82
4.1.3.3	Channel access method.....	82
4.1.3.3.1	IP-Protocol	83
4.1.3.3.1.1	RAW IP	87
4.1.3.3.1.2	IP Multicast	87
4.1.3.3.2	TCP Protocol.....	87
4.1.3.3.3	UDP.....	88
4.1.3.3.4	ARP.....	88
4.1.3.4	Administration and Diagnosis Protocols	89
4.1.3.4.1	BootP (Bootstrap Protocol).....	89
4.1.3.4.2	HTTP (HyperText Transfer Protocol)	90
4.1.3.4.3	DHCP (Dynamic Host Configuration Protocol).....	91
4.1.3.4.4	DNS (Domain Name Systems)	92
4.1.3.4.5	SNTP-Client (Simple Network Time Protocol).....	92
4.1.3.4.6	FTP-Server (File Transfer Protocol).....	92
4.1.3.4.7	SMTP (Simple Mail Transfer Protocol)	94
4.1.3.5	Application Protocols	94
4.2	MODBUS Functions	95
4.2.1	General.....	95
4.2.2	Use of the MODBUS Functions.....	97
4.2.3	Description of the MODBUS Functions	98
4.2.3.1	Function Code FC1 (Read Coils).....	99
4.2.3.2	Function Code FC2 (Read Input Discretes).....	100
4.2.3.3	Function Code FC3 (Read multiple registers)	101
4.2.3.4	Function code FC4 (Read input registers)	102
4.2.3.5	Function Code FC5 (Write Coil)	103
4.2.3.6	Function Code FC6 (Write single register).....	104
4.2.3.7	Function code FC7 (Read Exception Status).....	105
4.2.3.8	Function Code FC11 (Get comm event counter).....	106
4.2.3.9	Function Code FC15 (Force Multiple Coils).....	107
4.2.3.10	Function Code FC16 (Write multiple registers)	108
4.2.3.11	Function Code FC23 (Read/Write multiple registers).....	108
4.2.4	MODBUS Register Mapping	110
4.2.5	Internal Variables	111
4.2.5.1	Description of the internal variables.....	113
4.2.5.1.1	Watchdog (Fieldbus failure)	113
4.2.5.1.2	Watchdog Register:.....	113
4.2.5.2	Diagnostic Functions	118
4.2.5.3	Configuration Functions	118
4.2.5.4	Firmware Information.....	120
4.2.5.5	Constant Registers	122

5 I/O Modules	124
5.1 Overview	124
5.1.1 Digital Input Modules.....	124
5.1.2 Digital Output Modules	126
5.1.3 Analog Input Modules.....	127
5.1.4 Analog Output Modules	128
5.1.5 Special Modules	129
5.1.6 System Modules.....	130
5.2 Process Data Architecture for MODBUS/TCP	131
5.2.1 Digital Input Modules.....	131
5.2.2 Digital Output Modules	133
5.2.3 Analog Input Modules	137
5.2.4 Analog Output Modules	138
5.2.5 Specialty Modules	139
5.2.6 System Modules.....	151
6 Application Examples	152
6.1 Test of MODBUS protocol and fieldbus nodes	152
6.2 Visualization and control using SCADA software.....	152
7 Use in Hazardous Environments	155
7.1 Foreword	155
7.2 Protective measures	155
7.3 Classification meeting CENELEC and IEC	155
7.3.1 Divisions	155
7.3.2 Explosion protection group	156
7.3.3 Unit categories	157
7.3.4 Temperature classes.....	157
7.3.5 Types of ignition protection	158
7.4 Classifications meeting the NEC 500.....	159
7.4.1 Divisions	159
7.4.2 Explosion protection groups.....	159
7.4.3 Temperature classes.....	160
7.5 Identification	161
7.5.1 For Europe	161
7.5.2 For America	162
7.6 Installation regulations	163
8 Glossary.....	165
9 Literature List	177
10 Index.....	178

1 Important Notes

This section provides only a summary of the most important safety requirements and notes which will be mentioned in the individual sections. To protect your health and prevent damage to the devices, it is essential to read and carefully follow the safety guidelines.

1.1 Legal Principles

1.1.1 Copyright

This manual including all figures and illustrations contained therein is subject to copyright. Any use of this manual which infringes the copyright provisions stipulated herein, is not permitted. Reproduction, translation and electronic and phototechnical archiving and amendments require the written consent of WAGO Kontakttechnik GmbH & Co. KG, Minden. Non-observance will entail the right of claims for damages.

WAGO Kontakttechnik GmbH & Co. KG reserves the right of changes serving technical progress.

All rights developing from the issue of a patent or the legal protection of utility patents are reserved to WAGO Kontakttechnik GmbH & Co. KG.

Third-party products are always indicated without any notes concerning patent rights. Thus, the existence of such rights must not be excluded.

1.1.2 Personnel Qualification

The use of the product described in this manual requires special qualifications, as shown in the following table:

Activity	Electrical specialist	Instructed personnel*)	Specialists**) having qualifications in PLC programming
Assembly	X	X	
Commissioning	X		X
Programming			X
Maintenance	X	X	
Troubleshooting	X		
Disassembly	X	X	

*) Instructed persons have been trained by qualified personnel or electrical specialists.

**) A specialist is someone who, through technical training, knowledge and experience, demonstrates the ability to meet the relevant specifications and identify potential dangers in the mentioned field of activity.

All personnel must be familiar with the applicable standards.

WAGO Kontakttechnik GmbH & Co. KG declines any liability resulting from

improper action and damage to WAGO products and third party products due to non-observance of the information contained in this manual.

1.1.3 Conforming Use of Series 750

The couplers and controllers of the modular I/O System 750 receive digital and analog signals from the I/O modules and sensors and transmit them to the actuators or higher level control systems. Using the WAGO controllers, the signals can also be (pre-)processed.

The device is designed for IP20 protection class. It is protected against finger touch and solid impurities up to 12.5mm diameter, but not against water penetration. Unless otherwise specified, the device must not be operated in wet and dusty environments.

1.1.4 Technical Condition of the Devices

For each individual application, the components are supplied from the factory with a dedicated hardware and software configuration. Changes in hardware, software and firmware are only admitted within the framework of the possibilities documented in the manuals. All changes to the hardware or software and the non-conforming use of the components entail the exclusion of liability on the part of WAGO Kontakttechnik GmbH & Co. KG.

Please direct any requirements pertaining to a modified and/or new hardware or software configuration directly to WAGO Kontakttechnik GmbH & Co. KG.

1.2 Standards and Regulations for Operating the 750 Series

Please observe the standards and regulations that are relevant to your installation:

- The data and power lines must be connected and installed in compliance with the standards to avoid failures on your installation and eliminate any danger to personnel.
- For installation, startup, maintenance and repair, please observe the accident prevention regulations of your machine (e.g. BGV A 3, "Electrical Installations and Equipment").
- Emergency stop functions and equipment must not be made ineffective. See relevant standards (e.g. DIN EN 418).
- Your installation must be equipped in accordance to the EMC guidelines so that electromagnetic interferences can be eliminated.
- Operating 750 Series components in home applications without further measures is only permitted if they meet the emission limits (emissions of interference) according to EN 61000-6-3. You will find the relevant information in the section on "WAGO-I/O-SYSTEM 750" → "System Description" → "Technical Data".

- Please observe the safety measures against electrostatic discharge according to DIN EN 61340-5-1/-3. When handling the modules, ensure that the environment (persons, workplace and packing) is well grounded.
- The relevant valid and applicable standards and guidelines concerning the installation of switch cabinets are to be observed.

1.3 Symbols



Danger

Always observe this information to protect persons from injury.



Warning

Always observe this information to prevent damage to the device.



Attention

Marginal conditions that must always be observed to ensure smooth and efficient operation.



ESD (Electrostatic Discharge)

Warning of damage to the components through electrostatic discharge. Observe the precautionary measure for handling components at risk of electrostatic discharge.



Note

Make important notes that are to be complied with so that a trouble-free and efficient device operation can be guaranteed.



Additional Information

References to additional literature, manuals, data sheets and INTERNET pages.

1.4 Safety Information

When connecting the device to your installation and during operation, the following safety notes must be observed:



Danger

The WAGO-I/O-SYSTEM 750 and its components are an open system. It must only be assembled in housings, cabinets or in electrical operation rooms. Access is only permitted via a key or tool to authorized qualified personnel.



Danger

All power sources to the device must always be switched off before carrying out any installation, repair or maintenance work.



Warning

Replace defective or damaged device/module (e.g. in the event of deformed contacts), as the functionality of fieldbus station in question can no longer be ensured on a long-term basis.



Warning

The components are not resistant against materials having seeping and insulating properties. Belonging to this group of materials is: e.g. aerosols, silicones, triglycerides (found in some hand creams). If it cannot be ruled out that these materials appear in the component environment, then the components must be installed in an enclosure that is resistant against the above mentioned materials. Clean tools and materials are generally required to operate the device/module.



Warning

Soiled contacts must be cleaned using oil-free compressed air or with ethyl alcohol and leather cloths.



Warning

Do not use contact sprays, which could possibly impair the functioning of the contact area.



Warning

Avoid reverse polarity of data and power lines, as this may damage the devices.



ESD (Electrostatic Discharge)

The devices are equipped with electronic components that may be destroyed by electrostatic discharge when touched.

1.5 Font Conventions

<i>italic</i>	Names of paths and files are marked in italic. e.g.: <i>C:\Programs\WAGO-IO-CHECK</i>
<i>italic</i>	Menu items are marked in bold italic. e.g.: <i>Save</i>
\	A backslash between two names characterizes the selection of a menu point from a menu. e.g.: <i>File \ New</i>
END	Press buttons are marked as bold with small capitals e.g.: ENTER
<>	Keys are marked bold within angle brackets e.g.: <F5>
Courier	The print font for program codes is Courier. e.g.: END_VAR

1.6 Number Notation

Number code	Example	Note
Decimal	100	Normal notation
Hexadecimal	0x64	C notation
Binary	'100' '0110.0100'	Within ', Nibble separated with dots

1.7 Scope

This manual describes the fieldbus coupler for ETHERNET 10/100 MBit/s of the WAGO-I/O-SYSTEM 750.

1.8 Important Comments for Starting up



Attention

For the start-up of the coupler 750-341 important notes are to be considered, because it strongly differentiates in some points of starting up the WAGO ETHERNET coupler 750-342.

Read for this the chapter: “Starting up ETHERNET TCP/IP fieldbus nodes“.

1.9 Abbreviation

AI	Analog Input
AO	Analog Output
DI	Digital Input
DO	Digital Output
I/O	Input/Output
ID	Identifier

2 The WAGO-I/O-SYSTEM 750

2.1 System Description

The WAGO-I/O-SYSTEM 750 is a modular, fieldbus independent I/O system. It is comprised of a fieldbus coupler/controller (1) and connected fieldbus modules (2) for any type of signal. Together, these make up the fieldbus node. The end module (3) completes the node.

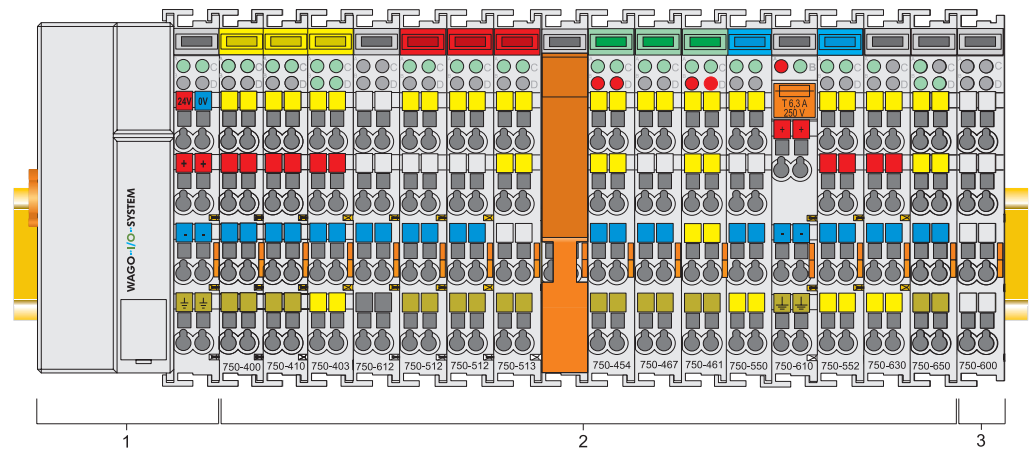

Fig. 2-1: Fieldbus node

g0xxx00x

Couplers/controllers for fieldbus systems such as PROFIBUS, INTERBUS, ETHERNET TCP/IP, CAN (CANopen, DeviceNet, CAL), MODBUS, LON and others are available.

The coupler/controller contains the fieldbus interface, electronics and a power supply terminal. The fieldbus interface forms the physical interface to the relevant fieldbus. The electronics process the data of the bus modules and make it available for the fieldbus communication. The 24 V system supply and the 24 V field supply are fed in via the integrated power supply terminal. The fieldbus coupler communicates via the relevant fieldbus. The programmable fieldbus controller (PFC) enables the implementation of additional PLC functions. Programming is done with the WAGO-I/O-PRO 32 in accordance with IEC 61131-3.

Bus modules for diverse digital and analog I/O functions as well as special functions can be connected to the coupler/controller. The communication between the coupler/controller and the bus modules is carried out via an internal bus.

The WAGO-I/O-SYSTEM 750 has a clear port level with LEDs for status indication, insertable mini WSB markers and pullout group marker carriers. The 3-wire technology supplemented by a ground wire connection allows for direct sensor/actuator wiring.

2.2 Technical Data

Mechanic	
Material	Polycarbonate, Polyamide 6.6
Dimensions W x H* x L * from upper edge of DIN 35 rail	
- Coupler/Controller (Standard)	- 51 mm x 65 mm x 100 mm
- Coupler/Controller (ECO)	- 50 mm x 65 mm x 100 mm
- Coupler/Controller (FireWire)	- 62 mm x 65 mm x 100 mm
- I/O module, single	- 12 mm x 64 mm x 100 mm
- I/O module, double	- 24 mm x 64 mm x 100 mm
- I/O module, fourfold	- 48 mm x 64 mm x 100 mm
Installation	on DIN 35 with interlock
modular by	double featherkey-dovetail
Mounting position	any position
Marking	marking label type 247 and 248 paper marking label 8 x 47 mm
Connection	
Connection type	CAGE CLAMP®
Wire range	0.08 mm ² ... 2.5 mm ² , AWG 28-14
Stripped length	8 – 9 mm, 9 – 10 mm for components with pluggable wiring (753-xxx)
Contacts	
Power jumpers contacts	blade/spring contact self-cleaning
Current via power contacts _{S_{max}}	10 A
Voltage drop at I _{max}	< 1 V/64 modules
Data contacts	slide contact, hard gold plated 1.5 µm, self-cleaning
Climatic environmental conditions	
Operating temperature	0 °C ... 55 °C, -20 °C ... +60 °C for components with extended temperature range (750-xxx/025-xxx)
Storage temperature	-20 °C ... +85 °C
Relative humidity	5 % to 95 % without condensation
Resistance to harmful substances	acc. to IEC 60068-2-42 and IEC 60068-2-43
Maximum pollutant concentration at relative humidity < 75%	SO ₂ ≤ 25 ppm H ₂ S ≤ 10 ppm
Special conditions	Ensure that additional measures for components are taken, which are used in an environment involving: – dust, caustic vapors or gasses – ionization radiation.

Safe electrical isolation				
Air and creepage distance	acc. to IEC 60664-1			
Degree of pollution acc. To IEC 61131-2	2			
Degree of protection				
Degree of protection	IP 20			
Electromagnetic compatibility				
Immunity to interference for industrial areas acc. to EN 61000-6-2 (2001)				
Test specification	Test values	Strength class	Evaluation criteria	
EN 61000-4-2 ESD	4 kV/8 kV (contact/air)	2/3	B	
EN 61000-4-3 electromagnetic fields	10 V/m 80 MHz ... 1 GHz	3	A	
EN 61000-4-4 burst	1 kV/2 kV (data/supply)	2/3	B	
EN 61000-4-5 surge	Data:	-/- (line/line)	B	
		1 kV (line/earth)		2
	DC supply:	0.5 kV (line/line)	1	B
		0.5 kV (line/earth)	1	
	AC supply:	1 kV (line/line)	2	B
		2 kV (line/earth)	3	
EN 61000-4-6 RF disturbances	10 V/m 80 % AM (0.15 ... 80 MHz)	3	A	
Emission of interference for industrial areas acc. to EN 61000-6-4 (2001)				
Test specification	Limit values/[QP]*	Frequency range	Distance	
EN 55011 (AC supply, conducted)	79 dB (µV)	150 kHz ... 500 kHz		
	73 dB (µV)	500 kHz ... 30 MHz		
EN 55011 (radiated)	40 dB (µV/m)	30 MHz ... 230 MHz	10 m	
	47 dB (µV/m)	230 MHz ... 1 GHz	10 m	
Emission of interference for residential areas acc. to EN 61000-6-3 (2001)				
Test specification	Limit values/[QP]*	Frequency range	Distance	
EN 55022 (AC supply, conducted)	66 ... 56 dB (µV)	150 kHz ... 500 kHz		
	56 dB (µV)	500 kHz ... 5 MHz		
	60 dB (µV)	5 MHz ... 30 MHz		
EN 55022 (DC supply/data, conducted)	40 ... 30 dB (µA)	150 kHz ... 500 kHz		
	30 dB (µA)	500 kHz ... 30 MHz		
EN 55022 (radiated)	30 dB (µV/m)	30 MHz ... 230 MHz	10 m	
	37 dB (µV/m)	230 MHz ... 1 GHz	10 m	

Mechanical strength acc. to IEC 61131-2		
Test specification	Frequency range	Limit value
IEC 60068-2-6 vibration	$5 \text{ Hz} \leq f < 9 \text{ Hz}$	1.75 mm amplitude (permanent) 3.5 mm amplitude (short term)
	$9 \text{ Hz} \leq f < 150 \text{ Hz}$	0.5 g (permanent) 1 g (short term)
	Note on vibration test: a) Frequency change: max. 1 octave/minute b) Vibration direction: 3 axes	
IEC 60068-2-27 shock		15 g
	Note on shock test: a) Type of shock: half sine b) Shock duration: 11 ms c) Shock direction: 3x in positive and 3x in negative direction for each of the three mutually perpendicular axes of the test specimen	
IEC 60068-2-32 free fall		1 m (module in original packing)

*) QP: Quasi Peak



Note:

If the technical data of components differ from the values described here, the technical data shown in the manuals of the respective components shall be valid.

For Products of the WAGO-I/O-SYSTEM 750 with ship specific approvals, supplementary guidelines are valid:

Electromagnetic compatibility			
Immunity to interference acc. to Germanischer Lloyd (2003)			
Test specification	Test values	Strength class	Evaluation criteria
IEC 61000-4-2 ESD	6 kV/8 kV (contact/air)	3/3	B
IEC 61000-4-3 electromagnetic fields	10 V/m 80 MHz ... 2 GHz	3	A
IEC 61000-4-4 burst	1 kV/2 kV (data/supply)	2/3	A
IEC 61000-4-5 surge	AC/DC	0.5 kV (line/line)	1
	Supply:	1 kV (line/earth)	2
IEC 61000-4-6 RF disturbances	10 V/m 80 % AM (0.15 ... 80 MHz)	3	A
Type test AF disturbances (harmonic waves)	3 V, 2 W	-	A
Type test high voltage	755 V DC 1500 V AC	-	-
Emission of interference acc. to Germanischer Lloyd (2003)			
Test specification	Limit values	Frequency range	Distance
Type test (EMC1, conducted) allows for ship bridge control applications	96 ... 50 dB (µV)	10 kHz ... 150 kHz	
	60 ... 50 dB (µV)	150 kHz ... 350 kHz	
	50 dB (µV)	350 kHz ... 30 MHz	
Type test (EMC1, radiated) allows for ship bridge control applications außer für:	80 ... 52 dB (µV/m)	150 kHz ... 300 kHz	3 m
	52 ... 34 dB (µV/m)	300 kHz ... 30 MHz	3 m
	54 dB (µV/m)	30 MHz ... 2 GHz	3 m
	24 dB (µV/m)	156 MHz ... 165 MHz	3 m
Mechanical strength acc. to Germanischer Lloyd (2003)			
Test specification	Frequency range	Limit value	
IEC 60068-2-6 vibration (category A – D)	$2 \text{ Hz} \leq f < 25 \text{ Hz}$	± 1.6 mm amplitude (permanent)	
	$25 \text{ Hz} \leq f < 100 \text{ Hz}$	4 g (permanent)	
Note on vibration test: a) Frequency change: max. 1 octave/minute b) Vibration direction: 3 axes			

Range of application	Required specification emission of interference	Required specification immunity to interference
Industrial areas	EN 61000-6-4 (2001)	EN 61000-6-2 (2001)
Residential areas	EN 61000-6-3 (2001)*)	EN 61000-6-1 (2001)

*) The system meets the requirements on emission of interference in residential areas with the fieldbus coupler/controller for:

ETHERNET 750-342/-841/-842/-860

LonWorks 750-319/-819

CANopen 750-337/-837

DeviceNet 750-306/-806

MODBUS 750-312/-314/ -315/ -316
 750-812/-814/ -815/ -816

With a special permit, the system can also be implemented with other fieldbus couplers/controllers in residential areas (housing, commercial and business areas, small-scale enterprises). The special permit can be obtained from an authority or inspection office. In Germany, the Federal Office for Post and Telecommunications and its branch offices issues the permit.

It is possible to use other field bus couplers/controllers under certain boundary conditions. Please contact WAGO Kontakttechnik GmbH & Co. KG.

Maximum power dissipation of the components	
Bus modules	0.8 W / bus terminal (total power dissipation, system/field)
Fieldbus coupler/controller	2.0 W / coupler/controller



Warning

The power dissipation of all installed components must not exceed the maximum conductible power of the housing (cabinet).

When dimensioning the housing, care is to be taken that even under high external temperatures, the temperature inside the housing does not exceed the permissible ambient temperature of 55 °C.

2.3 Manufacturing Number

The manufacturing number indicates the delivery status directly after production.

This number is part of the lateral marking on the component.

In addition, starting from calendar week 43/2000 the manufacturing number is also printed on the cover of the configuration and programming interface of the fieldbus coupler or controller.

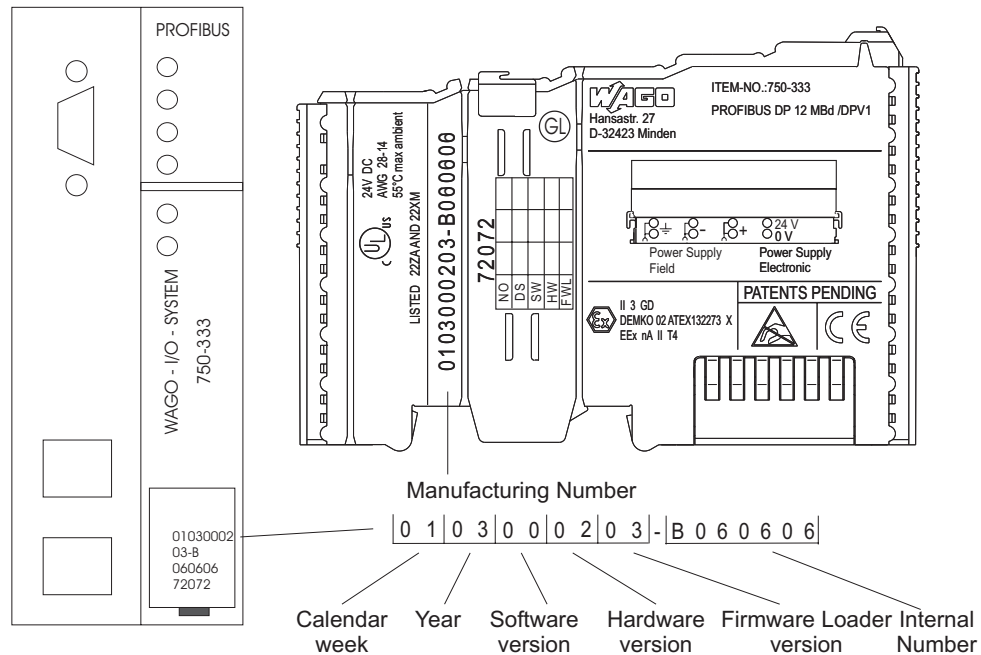

Fig. 2-3: Example: Manufacturing Number of a PROFIBUS fieldbus coupler 750-333 g01xx15e

The manufacturing number consists of the production week and year, the software version (if available), the hardware version of the component, the firmware loader (if available) and further internal information for WAGO Kontakttechnik GmbH.

2.4 Component Update

For the case of an Update of one component, the lateral marking on each component contains a prepared matrix.

This matrix makes columns available for altogether three updates to the entry of the current update data, like production order number (NO; starting from calendar week 13/2004), update date (DS), software version (SW), hardware version (HW) and the firmware loader version (FWL, if available).

Update Matrix

Current Version data for:	1. Update	2. Update	3. Update		
Production Order Number	NO				← Only starting from calendar week 13/2004
Datestamp	DS				
Software index	SW				
Hardware index	HW				
Firmware loader index	FWL				← Only for coupler/ controller

If the update of a component took place, the current version data are registered into the columns of the matrix.

Additionally with the update of a fieldbus coupler or controller also the cover of the configuration and programming interface of the coupler or controller is printed on with the current manufacturing and production order number.

The original manufacturing data on the housing of the component remain thereby.

2.5 Storage, Assembly and Transport

Wherever possible, the components are to be stored in their original packaging. Likewise, the original packaging provides optimal protection during transport.

When assembling or repacking the components, the contacts must not be soiled or damaged. The components must be stored and transported in appropriate containers/packaging. Thereby, the ESD information is to be regarded.

Statically shielded transport bags with metal coatings are to be used for the transport of open components for which soiling with amine, amide and silicone has been ruled out, e.g. 3M 1900E.

2.6 Mechanical Setup

2.6.1 Installation Position

Along with horizontal and vertical installation, all other installation positions are allowed.



Attention

In the case of vertical assembly, an end stop has to be mounted as an additional safeguard against slipping.

WAGO item 249-116 End stop for DIN 35 rail, 6 mm wide

WAGO item 249-117 End stop for DIN 35 rail, 10 mm wide

2.6.2 Total Expansion

The length of the module assembly (including one end module of 12mm width) that can be connected to the coupler/controller is 780mm. When assembled, the I/O modules have a maximum length of 768mm.

Examples:

- 64 I/O modules of 12mm width can be connected to one coupler/controller.
- 32 I/O modules of 24mm width can be connected to one coupler/controller.

Exception:

The number of connected I/O modules also depends on which type of coupler/controller is used. For example, the maximum number of I/O modules that can be connected to a Profibus coupler/controller is 63 without end module. The maximum total expansion of a node is calculated as follows:



Warning

The maximum total length of a node without coupler/controller must not exceed 780mm. Furthermore, restrictions made on certain types of couplers/controllers must be observed (e.g. for Profibus).

2.6.3 Assembly onto Carrier Rail

2.6.3.1 Carrier rail properties

All system components can be snapped directly onto a carrier rail in accordance with the European standard EN 50022 (DIN 35).



Warning

WAGO supplies standardized carrier rails that are optimal for use with the I/O system. If other carrier rails are used, then a technical inspection and approval of the rail by WAGO Kontakttechnik GmbH should take place.

Carrier rails have different mechanical and electrical properties. For the optimal system setup on a carrier rail, certain guidelines must be observed:

- The material must be non-corrosive.
- Most components have a contact to the carrier rail to ground electromagnetic disturbances. In order to avoid corrosion, this tin-plated carrier rail contact must not form a galvanic cell with the material of the carrier rail which generates a differential voltage above 0.5 V (saline solution of 0.3% at 20°C) .
- The carrier rail must optimally support the EMC measures integrated into the system and the shielding of the bus module connections.
- A sufficiently stable carrier rail should be selected and, if necessary, several mounting points (every 20 cm) should be used in order to prevent bending and twisting (torsion).
- The geometry of the carrier rail must not be altered in order to secure the safe hold of the components. In particular, when shortening or mounting the carrier rail, it must not be crushed or bent.
- The base of the I/O components extends into the profile of the carrier rail. For carrier rails with a height of 7.5 mm, mounting points are to be riveted under the node in the carrier rail (slotted head captive screws or blind rivets).

2.6.3.2 WAGO DIN Rail

WAGO carrier rails meet the electrical and mechanical requirements.

Item Number	Description
210-113 /-112	35 x 7.5; 1 mm; steel yellow chromated; slotted/unslotted
210-114 /-197	35 x 15; 1.5 mm; steel yellow chromated; slotted/unslotted
210-118	35 x 15; 2.3 mm; steel yellow chromated; unslotted
210-198	35 x 15; 2.3 mm; copper; unslotted
210-196	35 x 7.5; 1 mm; aluminum; unslotted

2.6.4 Spacing

The spacing between adjacent components, cable conduits, casing and frame sides must be maintained for the complete field bus node.

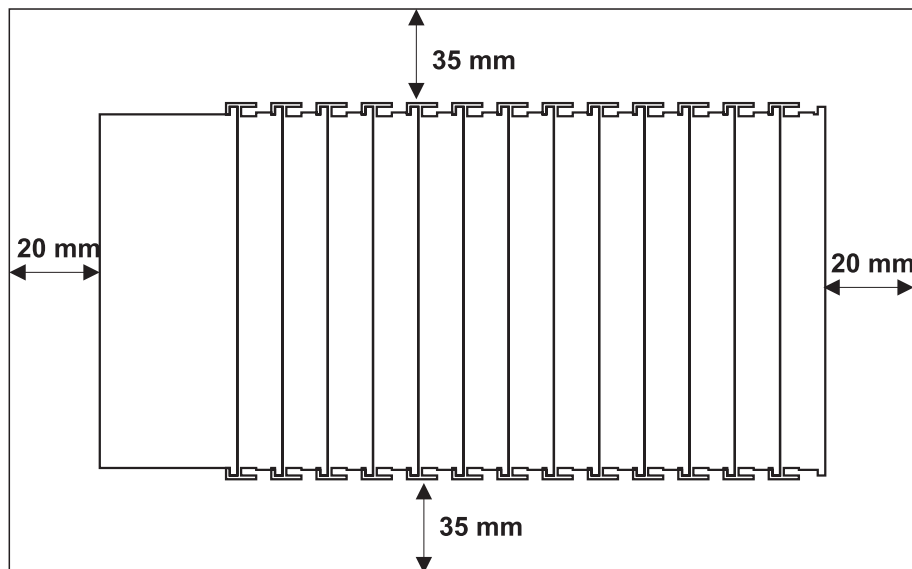

Fig. 2-4: Spacing

g01xx13x

The spacing creates room for heat transfer, installation or wiring. The spacing to cable conduits also prevents conducted electromagnetic interferences from influencing the operation.

2.6.5 Plugging and Removal of the Components



Warning

Before work is done on the components, the voltage supply must be turned off.

In order to safeguard the coupler/controller from jamming, it should be fixed onto the carrier rail with the locking disc. To do so, push on the upper groove of the locking disc using a screwdriver.

To pull out the fieldbus coupler/controller, release the locking disc by pressing on the bottom groove with a screwdriver and then pulling the orange colored unlocking lug.

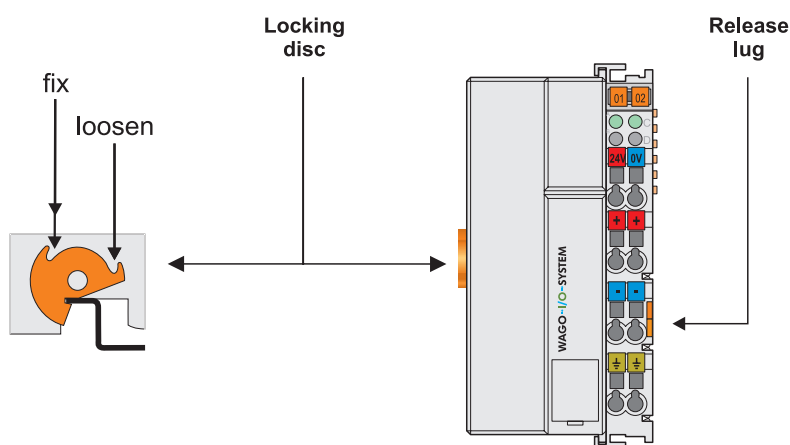

Fig. 2-5: Coupler/Controller and unlocking lug

g01xx12e

It is also possible to release an individual I/O module from the unit by pulling an unlocking lug.

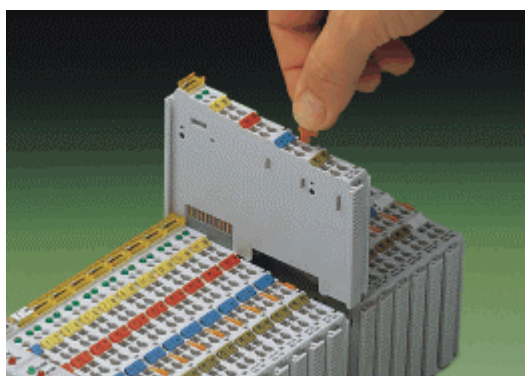

Fig. 2-6: removing bus terminal

p0xxx01x



Danger

Ensure that an interruption of the PE will not result in a condition which could endanger a person or equipment!

For planning the ring feeding of the ground wire, please see chapter 2.6.3.

2.6.6 Assembly Sequence

All system components can be snapped directly on a carrier rail in accordance with the European standard EN 50022 (DIN 35).

The reliable positioning and connection is made using a tongue and groove system. Due to the automatic locking, the individual components are securely seated on the rail after installing.

Starting with the coupler/controller, the bus modules are assembled adjacent to each other according to the project planning. Errors in the planning of the node in terms of the potential groups (connection via the power contacts) are recognized, as the bus modules with power contacts (male contacts) cannot be linked to bus modules with fewer power contacts.



Attention

Always link the bus modules with the coupler/controller, and always plug from above.



Warning

Never plug bus modules from the direction of the end terminal. A ground wire power contact, which is inserted into a terminal without contacts, e.g. a 4-channel digital input module, has a decreased air and creepage distance to the neighboring contact in the example DI4.

Always terminate the fieldbus node with an end module (750-600).

2.6.7 Internal Bus/Data Contacts

Communication between the coupler/controller and the bus modules as well as the system supply of the bus modules is carried out via the internal bus. It is comprised of 6 data contacts, which are available as self-cleaning gold spring contacts.

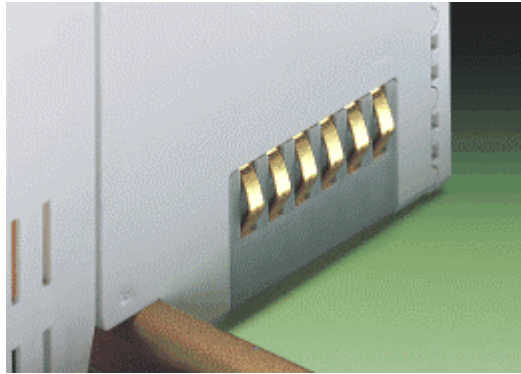

Fig. 2-7: Data contacts

p0xxx07x



Warning

Do not touch the gold spring contacts on the I/O modules in order to avoid soiling or scratching!



ESD (Electrostatic Discharge)

The modules are equipped with electronic components that may be destroyed by electrostatic discharge. When handling the modules, ensure that the environment (persons, workplace and packing) is well grounded. Avoid touching conductive components, e.g. gold contacts.

2.6.8 Power Contacts

Self-cleaning power contacts, are situated on the side of the components which further conduct the supply voltage for the field side. These contacts come as touchproof spring contacts on the right side of the coupler/controller and the bus module. As fitting counterparts the module has male contacts on the left side.



Danger

The power contacts are sharp-edged. Handle the module carefully to prevent injury.



Attention

Please take into consideration that some bus modules have no or only a few power jumper contacts. The design of some modules does not allow them to be physically assembled in rows, as the grooves for the male contacts are closed at the top.

Power jumper contacts

Blade	0	0	3	3	2
Spring		0	3	3	2

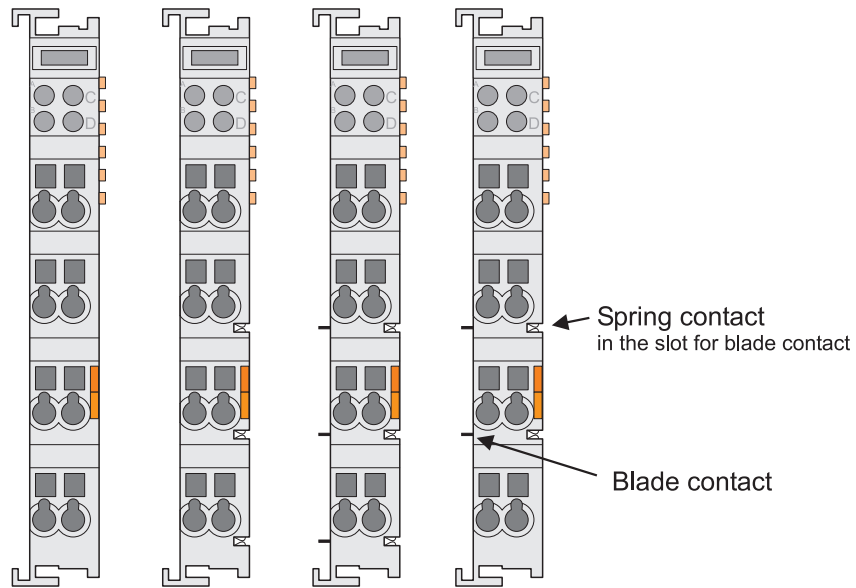

Fig. 2-8: Example for the arrangement of power contacts

g0xxx05e

Recommendation

With the WAGO ProServe® Software smartDESIGNER, the assembly of a fieldbus node can be configured. The configuration can be tested via the integrated accuracy check.

2.6.9 Wire connection

All components have CAGE CLAMP® connections.

The WAGO CAGE CLAMP® connection is appropriate for solid, stranded and fine-stranded conductors. Each clamping unit accommodates one conductor.

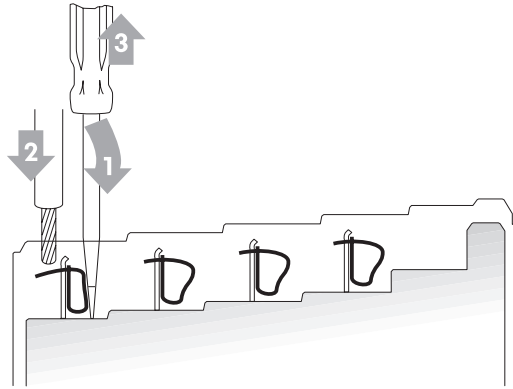

Fig. 2-9: CAGE CLAMP® Connection

g0xxx08x

The operating tool is inserted into the opening above the connection. This opens the CAGE CLAMP®. Subsequently the conductor can be inserted into the opening. After removing the operating tool, the conductor is safely clamped.

More than one conductor per connection is not permissible. If several conductors have to be made at one connection point, then they should be made away from the connection point using WAGO Terminal Blocks. The terminal blocks may be jumpered together and a single wire brought back to the I/O module connection point.



Attention

If it is unavoidable to jointly connect 2 conductors, then a ferrule must be used to join the wires together.

Ferrule:

Length	8 mm
Nominal cross section _{max.}	1 mm ² for 2 conductors with 0.5 mm ² each
WAGO Product	216-103 or products with comparable properties

2.7 Power Supply

2.7.1 Isolation

Within the fieldbus node, there are three electrically isolated potentials.

- Operational voltage for the fieldbus interface.
- Electronics of the couplers/controllers and the bus modules (internal bus).
- All bus modules have an electrical isolation between the electronics (internal bus, logic) and the field electronics. Some digital and analog input modules have each channel electrically isolated, please see catalog.

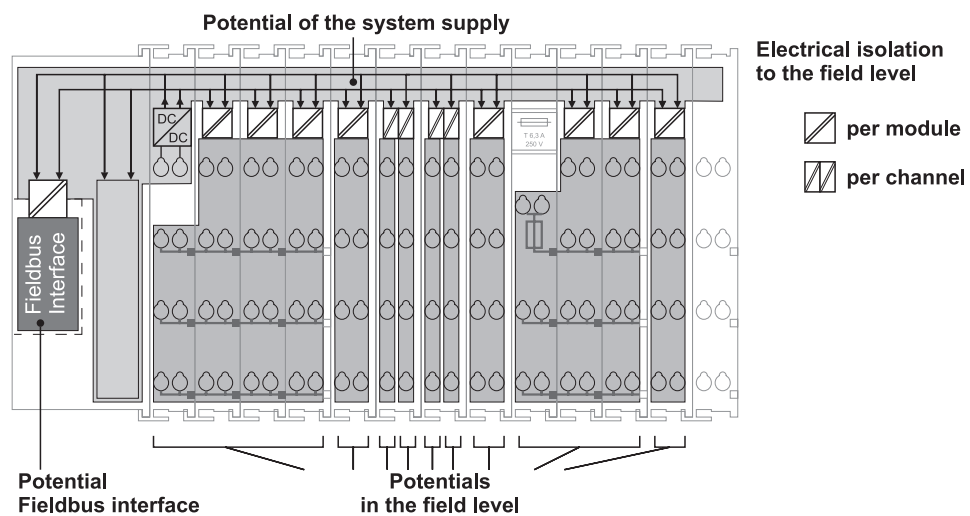

Fig. 2-10: Isolation

g0xxx01e



Attention

The ground wire connection must be present in each group. In order that all protective conductor functions are maintained under all circumstances, it is recommended that a ground wire be connected at the beginning and end of a potential group. (ring format, please see chapter "2.8.3"). Thus, if a bus module comes loose from a composite during servicing, then the protective conductor connection is still guaranteed for all connected field devices.

When using a joint power supply unit for the 24 V system supply and the 24 V field supply, the electrical isolation between the internal bus and the field level is eliminated for the potential group.

2.7.2 System Supply

2.7.2.1 Connection

The WAGO-I/O-SYSTEM 750 requires a 24 V direct current system supply (-15% or +20%). The power supply is provided via the coupler/controller and, if necessary, in addition via the internal system supply modules (750-613). The voltage supply is reverse voltage protected.



Attention

The use of an incorrect supply voltage or frequency can cause severe damage to the component.

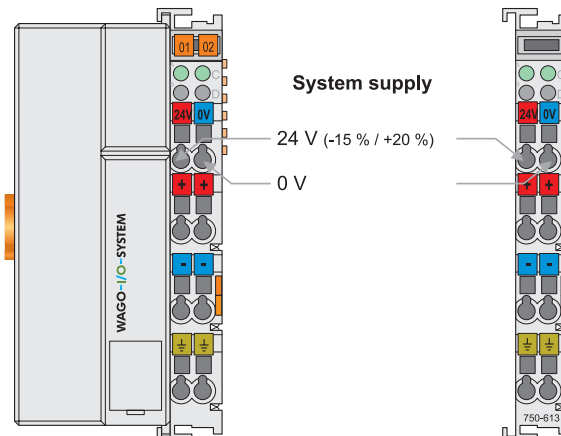

Fig. 2-11: System Supply

g0xxx02e

The direct current supplies all internal system components, e.g. coupler/controller electronics, fieldbus interface and bus modules via the internal bus (5 V system voltage). The 5 V system voltage is electrically connected to the 24 V system supply.

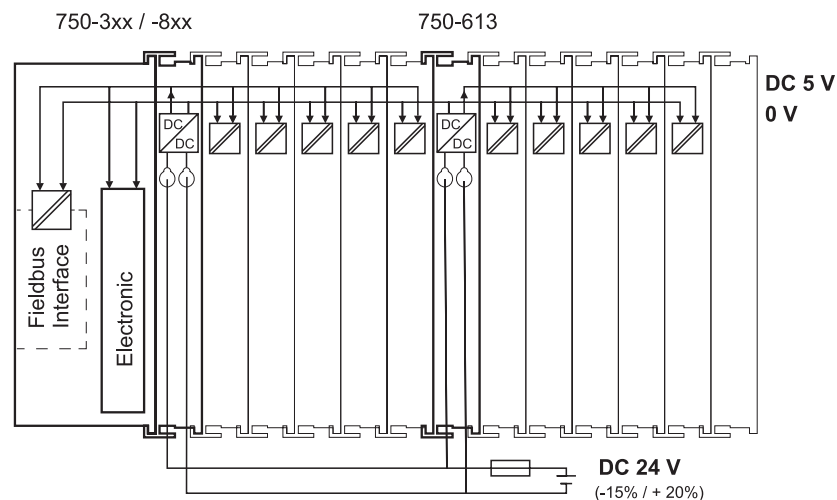

Fig. 2-12: System Voltage

g0xxx06e



Attention

Resetting the system by switching on and off the system supply, must take place simultaneously for all supply modules (coupler/controller and 750-613).

2.7.2.2 Alignment

Recommendation

A stable network supply cannot be taken for granted always and everywhere. Therefore, regulated power supply units should be used in order to guarantee the quality of the supply voltage.

The supply capacity of the coupler/controller or the internal system supply module (750-613) can be taken from the technical data of the components.

Internal current consumption*)	Current consumption via system voltage: 5 V for electronics of the bus modules and coupler/controller
Residual current for bus terminals*)	Available current for the bus modules. Provided by the bus power supply unit. See coupler/controller and internal system supply module (750-613)

*) cf. catalogue W4 Volume 3, manuals or Internet

Example

Coupler 750-301:
internal current consumption: 350 mA at 5V
residual current for
bus modules: 1650 mA at 5V
sum I(5V)_{total} : 2000 mA at 5V

The internal current consumption is indicated in the technical data for each bus terminal. In order to determine the overall requirement, add together the values of all bus modules in the node.



Attention

If the sum of the internal current consumption exceeds the residual current for bus modules, then an internal system supply module (750-613) must be placed before the module where the permissible residual current was exceeded.

Example:

A node with a PROFIBUS Coupler 750-333 consists of 20 relay modules (750-517) and 10 digital input modules (750-405).

Current consumption:
20* 90 mA = 1800 mA
10* 2 mA = 20 mA
Sum 1820 mA

The coupler can provide 1650 mA for the bus modules. Consequently, an internal system supply module (750-613), e.g. in the middle of the node, should be added.

Recommendation

With the WAGO ProServe® Software smartDESIGNER, the assembly of a fieldbus node can be configured. The configuration can be tested via the integrated accuracy check.

The maximum input current of the 24 V system supply is 500 mA. The exact electrical consumption ($I_{(24\text{ V})}$) can be determined with the following formulas:

Coupler/Controller

$I(5\text{ V})_{\text{total}} =$ Sum of all the internal current consumption of the connected bus modules
+ internal current consumption coupler/controller

750-613

$I(5\text{ V})_{\text{total}} =$ Sum of all the internal current consumption of the connected bus modules

Input current $I(24\text{ V}) = 5\text{ V} / 24\text{ V} * I(5\text{ V})_{\text{total}} / \eta$
 $\eta = 0.87$ (at nominal load)



Note

If the electrical consumption of the power supply point for the 24 V-system supply exceeds 500 mA, then the cause may be an improperly aligned node or a defect.

During the test, all outputs, in particular those of the relay modules, must be active.

2.7.3 Field Supply

2.7.3.1 Connection

Sensors and actuators can be directly connected to the relevant channel of the bus module in 1-/4 conductor connection technology. The bus module supplies power to the sensors and actuators. The input and output drivers of some bus modules require the field side supply voltage.

The coupler/controller provides field side power (DC 24V). In this case it is a passive power supply without protection equipment.

Power supply modules are available for other potentials, e.g. AC 230 V.

Likewise, with the aid of the power supply modules, various potentials can be set up. The connections are linked in pairs with a power contact.

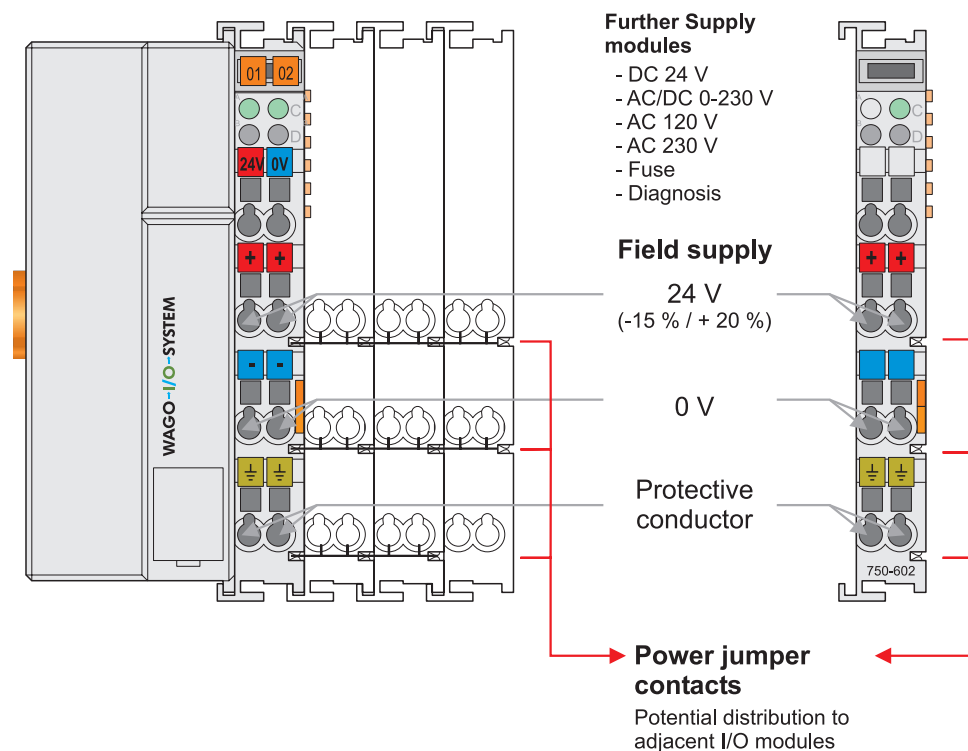

Fig. 2-13: Field Supply (Sensor/Actuator)

g0xxx03e

The supply voltage for the field side is automatically passed to the next module via the power jumper contacts when assembling the bus modules .

The current load of the power contacts must not exceed 10 A on a continual basis. The current load capacity between two connection terminals is identical to the load capacity of the connection wires.

By inserting an additional power supply module, the field supply via the power contacts is disrupted. From there a new power supply occurs which may also contain a new voltage potential.



Attention

Some bus modules have no or very few power contacts (depending on the I/O function). Due to this, the passing through of the relevant potential is disrupted. If a field supply is required for subsequent bus modules, then a power supply module must be used. Note the data sheets of the bus modules.

In the case of a node setup with different potentials, e.g. the alteration from DC 24 V to AC 230V, a spacer module should be used. The optical separation of the potentials acts as a warning to heed caution in the case of wiring and maintenance works. Thus, the results of wiring errors can be prevented.

2.7.3.2 Fusing

Internal fusing of the field supply is possible for various field voltages via an appropriate power supply module.

750-601	24 V DC, Supply/Fuse
750-609	230 V AC, Supply/Fuse
750-615	120 V AC, Supply/Fuse
750-610	24 V DC, Supply/Fuse/Diagnosis
750-611	230 V AC, Supply/Fuse/Diagnosis

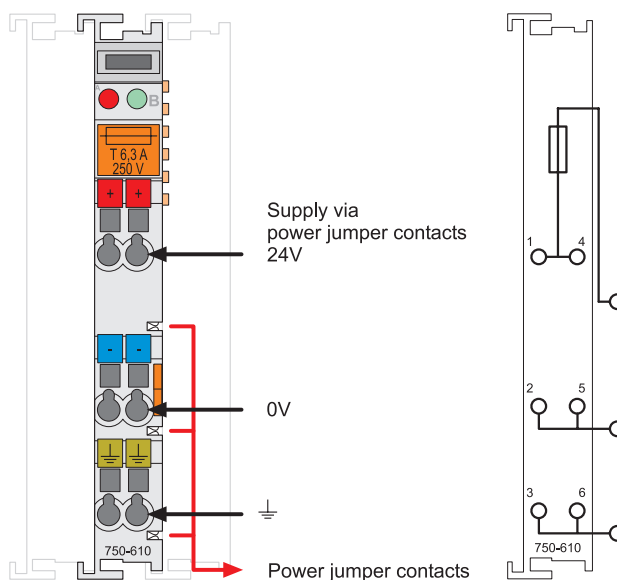

Fig. 2-14: Supply module with fuse carrier (Example 750-610)

g0xx09x



Warning

In the case of power supply modules with fuse holders, only fuses with a maximum dissipation of 1.6 W (IEC 127) must be used.

For UL approved systems only use UL approved fuses.

In order to insert or change a fuse, or to switch off the voltage in succeeding bus modules, the fuse holder may be pulled out. In order to do this, use a screwdriver for example, to reach into one of the slits (one on both sides) and pull out the holder.



Fig. 2-15: Removing the fuse carrier

p0xxx05x

Lifting the cover to the side opens the fuse carrier.



Fig. 2-16: Opening the fuse carrier

p0xxx03x



Fig. 2-17: Change fuse

p0xxx04x

After changing the fuse, the fuse carrier is pushed back into its original position.

Alternatively, fusing can be done externally. The fuse modules of the WAGO series 281 and 282 are suitable for this purpose.

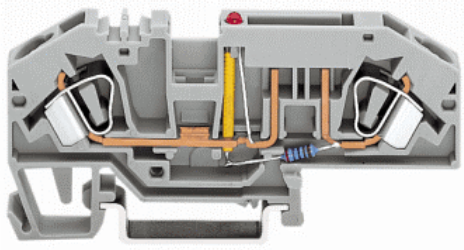

Fig. 2-18: Fuse modules for automotive fuses, Series 282

pf66800x

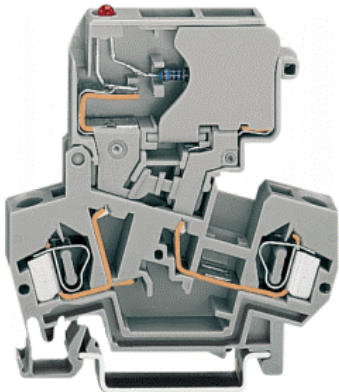

Fig. 2-19: Fuse modules with pivotable fuse carrier, Series 281

pe61100x

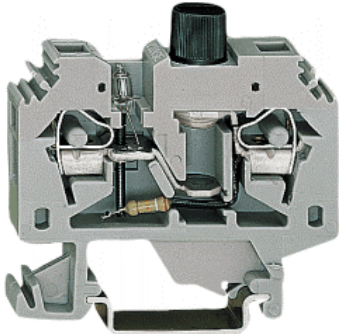

Fig. 2-20: Fuse modules, Series 282

pf12400x

2.7.4 Supplementary power supply regulations

The WAGO-I/O-SYSTEM 750 can also be used in shipbuilding or offshore and onshore areas of work (e.g. working platforms, loading plants). This is demonstrated by complying with the standards of influential classification companies such as Germanischer Lloyd and Lloyds Register.

Filter modules for 24-volt supply are required for the certified operation of the system.

Item No.	Name	Description
750-626	Supply filter	Filter module for system supply and field supply (24 V, 0 V), i.e. for field bus coupler/controller and bus power supply (750-613)
750-624	Supply filter	Filter module for the 24 V- field supply (750-602, 750-601, 750-610)

Therefore, the following power supply concept must be absolutely complied with.

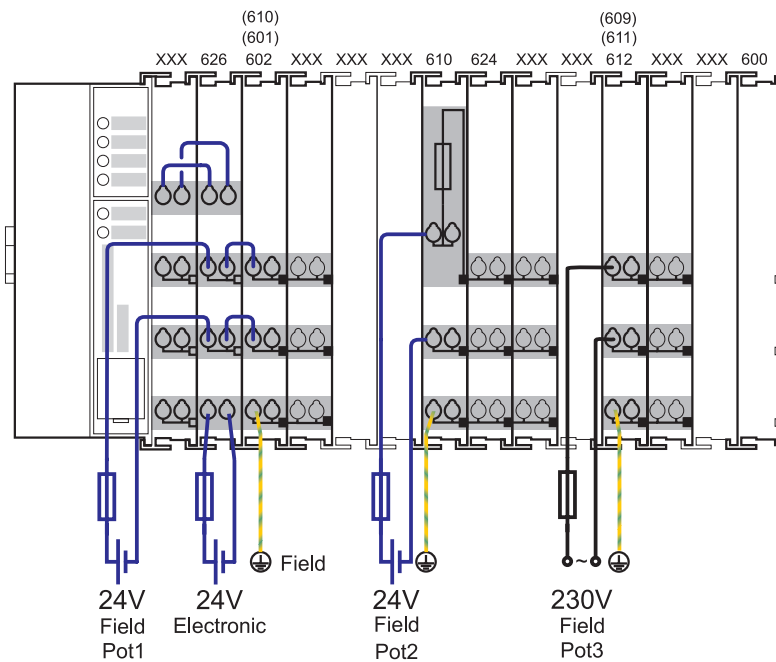

Fig. 2-21: Power supply concept

g01xx11e



Note

Another potential power terminal 750-601/602/610 must only be used behind the filter terminal 750-626 if the protective earth conductor is needed on the lower power contact or if a fuse protection is required.

2.7.5 Supply example



Note

The system supply and the field supply should be separated in order to ensure bus operation in the event of a short-circuit on the actuator side.

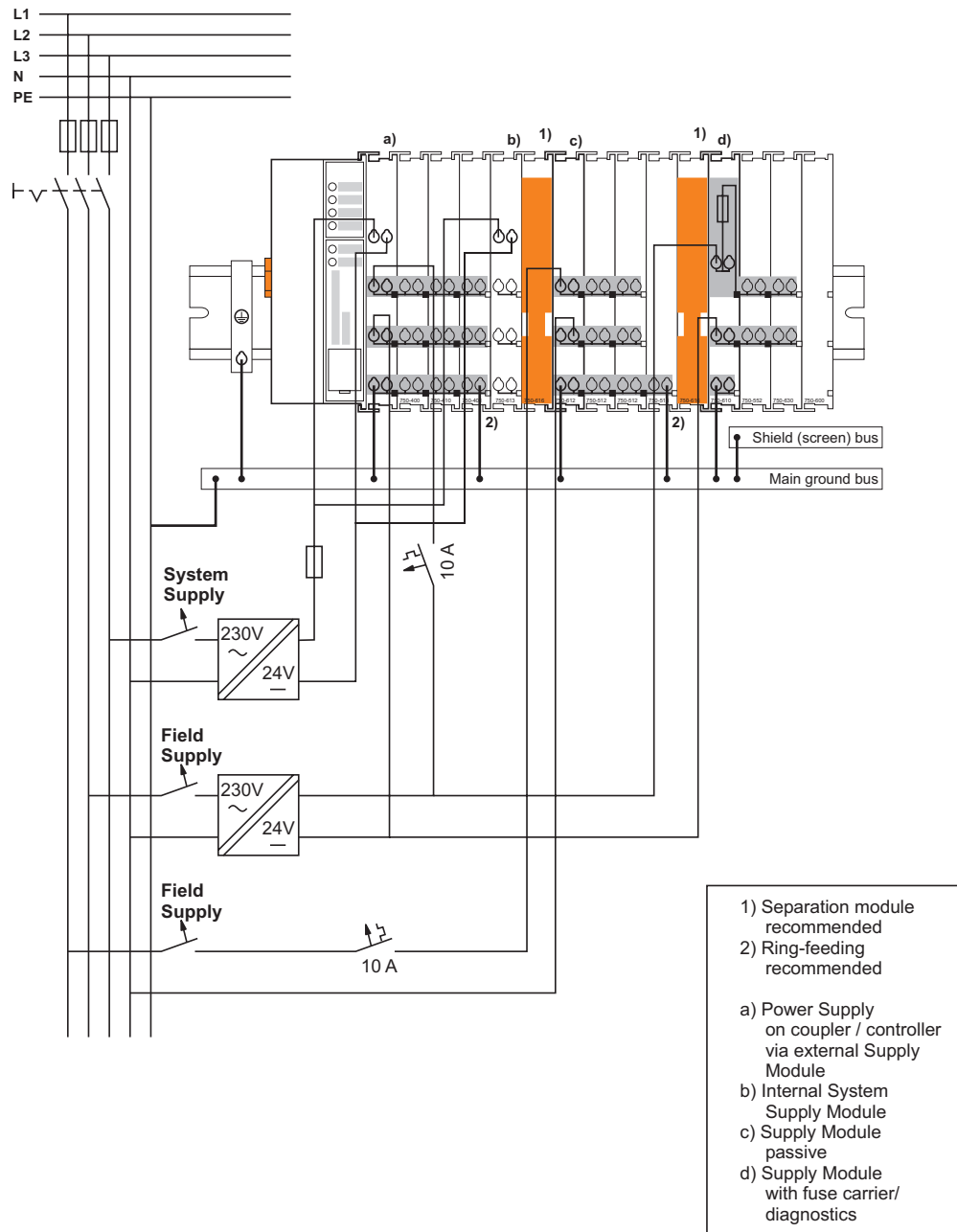

Fig. 2-22: Supply example

g0xxx04e

2.7.6 Power Supply Unit

The WAGO-I/O-SYSTEM 750 requires a 24 V direct current system supply with a maximum deviation of -15% or +20 %.

Recommendation

A stable network supply cannot be taken for granted always and everywhere. Therefore, regulated power supply units should be used in order to guarantee the quality of the supply voltage.

A buffer (200 µF per 1 A current load) should be provided for brief voltage dips. The I/O system buffers for approx 1 ms.

The electrical requirement for the field supply is to be determined individually for each power supply point. Thereby all loads through the field devices and bus modules should be considered. The field supply as well influences the bus modules, as the inputs and outputs of some bus modules require the voltage of the field supply.



Note

The system supply and the field supply should be isolated from the power supplies in order to ensure bus operation in the event of short circuits on the actuator side.

WAGO products Article No.	Description
787-903	Primary switched - mode, DC 24 V, 5 A wide input voltage range AC 85-264 V PFC (Power Factor Correction)
787-904	Primary switched - mode, DC 24 V, 10 A wide input voltage range AC 85-264 V PFC (Power Factor Correction)
787-912	Primary switched - mode, DC 24 V, 2 A wide input voltage range AC 85-264 V PFC (Power Factor Correction)
288-809 288-810 288-812 288-813	Rail-mounted modules with universal mounting carrier AC 115 V / DC 24 V; 0,5 A AC 230 V / DC 24 V; 0,5 A AC 230 V / DC 24 V; 2 A AC 115 V / DC 24 V; 2 A

2.8 Grounding

2.8.1 Grounding the DIN Rail

2.8.1.1 Framework Assembly

When setting up the framework, the carrier rail must be screwed together with the electrically conducting cabinet or housing frame. The framework or the housing must be grounded. The electronic connection is established via the screw. Thus, the carrier rail is grounded.



Attention

Care must be taken to ensure the flawless electrical connection between the carrier rail and the frame or housing in order to guarantee sufficient grounding.

2.8.1.2 Insulated Assembly

Insulated assembly has been achieved when there is constructively no direct conduction connection between the cabinet frame or machine parts and the carrier rail. Here the earth must be set up via an electrical conductor.

The connected grounding conductor should have a cross section of at least 4 mm².

Recommendation

The optimal insulated setup is a metallic assembly plate with grounding connection with an electrical conductive link with the carrier rail.

The separate grounding of the carrier rail can be easily set up with the aid of the WAGO ground wire terminals.

Article No.	Description
283-609	Single-conductor ground (earth) terminal block make an automatic contact to the carrier rail; conductor cross section: 0.2 -16 mm ² Note: Also order the end and intermediate plate (283-320)

2.8.2 Grounding Function

The grounding function increases the resistance against disturbances from electro-magnetic interferences. Some components in the I/O system have a carrier rail contact that dissipates electro-magnetic disturbances to the carrier rail.

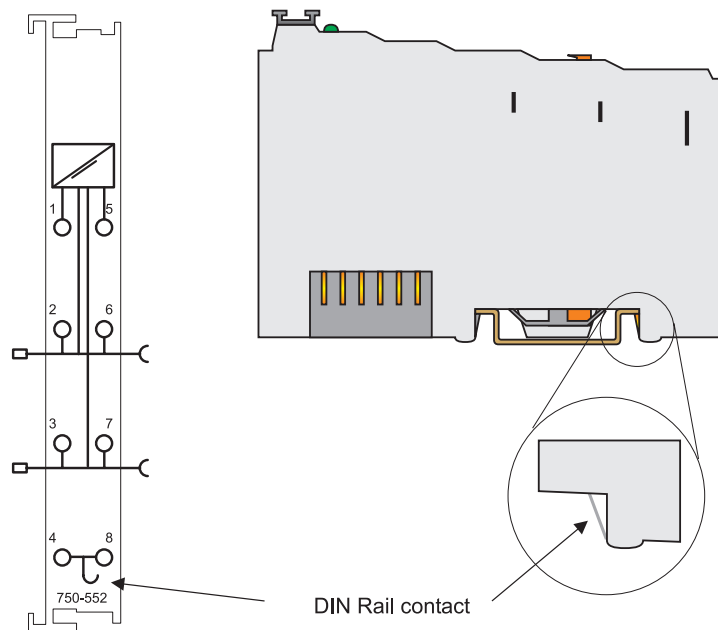

Fig. 2-23: Carrier rail contact

g0xxx10e



Attention

Care must be taken to ensure the direct electrical connection between the carrier rail contact and the carrier rail.

The carrier rail must be grounded.

For information on carrier rail properties, please see chapter 2.6.3.2.

2.8.3 Grounding Protection

For the field side, the ground wire is connected to the lowest connection terminals of the power supply module. The ground connection is then connected to the next module via the Power Jumper Contact (PJC). If the bus module has the lower power jumper contact, then the ground wire connection of the field devices can be directly connected to the lower connection terminals of the bus module.



Attention

Should the ground conductor connection of the power jumper contacts within the node become disrupted, e.g. due to a 4-channel bus terminal, the ground connection will need to be re-established.

The ring feeding of the grounding potential will increase the system safety. When one bus module is removed from the group, the grounding connection will remain intact.

The ring feeding method has the grounding conductor connected to the beginning and end of each potential group.

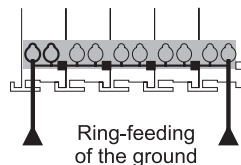

Fig. 2-24: Ring-feeding

g0xxx07e



Attention

The regulations relating to the place of assembly as well as the national regulations for maintenance and inspection of the grounding protection must be observed.

2.9 Shielding (Screening)

2.9.1 General

The shielding of the data and signal conductors reduces electromagnetic interferences thereby increasing the signal quality. Measurement errors, data transmission errors and even disturbances caused by overvoltage can be avoided.



Attention

Constant shielding is absolutely required in order to ensure the technical specifications in terms of the measurement accuracy.

The data and signal conductors should be separated from all high-voltage cables.

The cable shield should be potential. With this, incoming disturbances can be easily diverted.

The shielding should be placed over the entrance of the cabinet or housing in order to already repel disturbances at the entrance.

2.9.2 Bus Conductors

The shielding of the bus conductor is described in the relevant assembly guidelines and standards of the bus system.

2.9.3 Signal Conductors

Bus modules for most analog signals along with many of the interface bus modules include a connection for the shield.



Note

For better shield performance, the shield should have previously been placed over a large area. The WAGO shield connection system is suggested for such an application.

This suggestion is especially applicable when the equipment can have even current or high impulse formed currents running through it (for example through atmospheric end loading).

2.9.4 WAGO Shield (Screen) Connecting System

The WAGO Shield Connecting system includes a shield clamping saddle, a collection of rails and a variety of mounting feet. Together these allow many different possibilities. See catalog W4 volume 3 chapter 10.

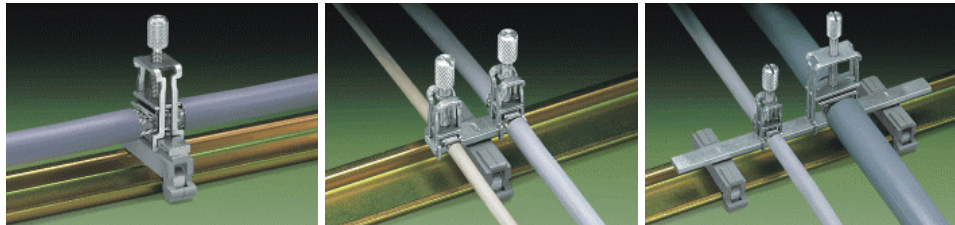

Fig. 2-25: WAGO Shield (Screen) Connecting System

p0xxx08x, p0xxx09x, and p0xxx10x

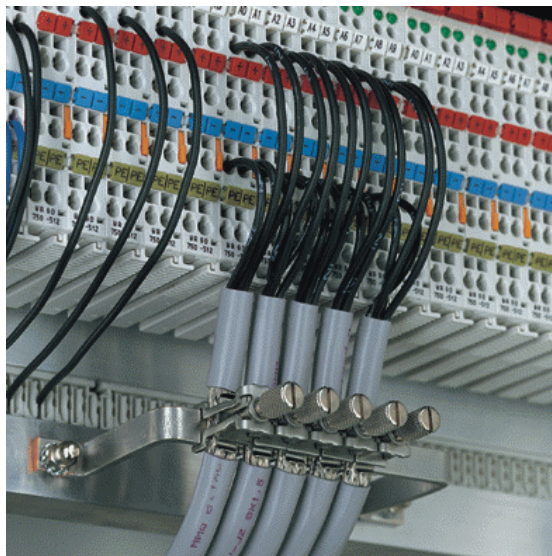

Fig. 2-26: Application of the WAGO Shield (Screen) Connecting System

p0xxx11x

2.10 Assembly Guidelines/Standards

DIN 60204,	Electrical equipping of machines
DIN EN 50178	Equipping of high-voltage systems with electronic components (replacement for VDE 0160)
EN 60439	Low voltage – switch box combinations

3 Fieldbus Coupler

3.1 Fieldbus coupler 750-342

3.1.1 Description

The fieldbus coupler 750-342 displays the peripheral data of all I/O modules in the WAGO-I/O-SYSTEM 750 on ETHERNET.

All sensor input signals are grouped in the coupler (slave) and transferred to the higher ranking controls (master) via the fieldbus. Process data linking is performed in the higher ranking controls. The controls put out the resulting data to the actuators via the bus and the node.

To be able to transmit process data via ETHERNET, the coupler supports a series of network protocols. Process data are exchanged with the aid of the MODBUS/TCP protocol.

Once the ETHERNET TCP/IP fieldbus coupler is connected, the coupler detects all I/O modules connected to the node and creates a local process image on this basis, which can be a mixed arrangement of analog (word-by-word data exchange) and digital (bit-by-bit data exchange) modules.

The local process image is subdivided into an input and an output data area.

The data of the analog modules are mapped into the process image in the order of their position downstream of the bus coupler.

The bits of the digital modules are grouped into words and also mapped into the process image as soon as mapping of the analog modules is completed. When the number of digital I/O's exceeds 16 bits, the coupler automatically starts the next word.

Also note that all process images start at WORD 0.

Information on configuration, status and the I/O data of the fieldbus node are stored in the fieldbus coupler as HTML pages. These pages can be seen via a standard WEB browser by typing the IP address, that you assigned the coupler, into the Address field of your web browser.

3.1.2 Hardware

3.1.2.1 View

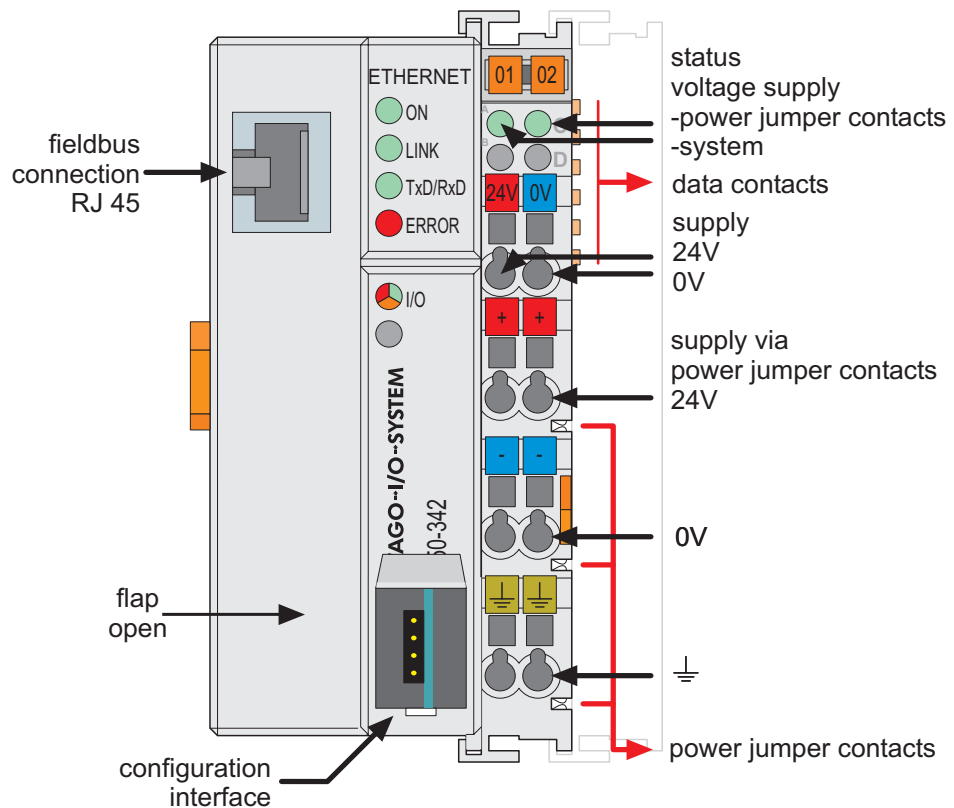

Fig. 3.1-1: Fieldbus coupler ETHERNET TCP/IP

G034200e

The fieldbus coupler is comprised of:

- Supply module which includes the internal system supply as well as power jumper contacts for the field supply via I/O module assemblies.
- Fieldbus interface with the bus connection RJ 45
- Display elements (LED's) for status display of the operation, the bus communication, the operating voltages as well as for fault messages and diagnosis
- Configuration Interface
- Electronics for communication with the I/O modules (internal bus) and the fieldbus interface

3.1.2.2 Device supply

The supply is made via terminal blocks with CAGE CLAMP® connection. The device supply is intended both for the system and the field units.

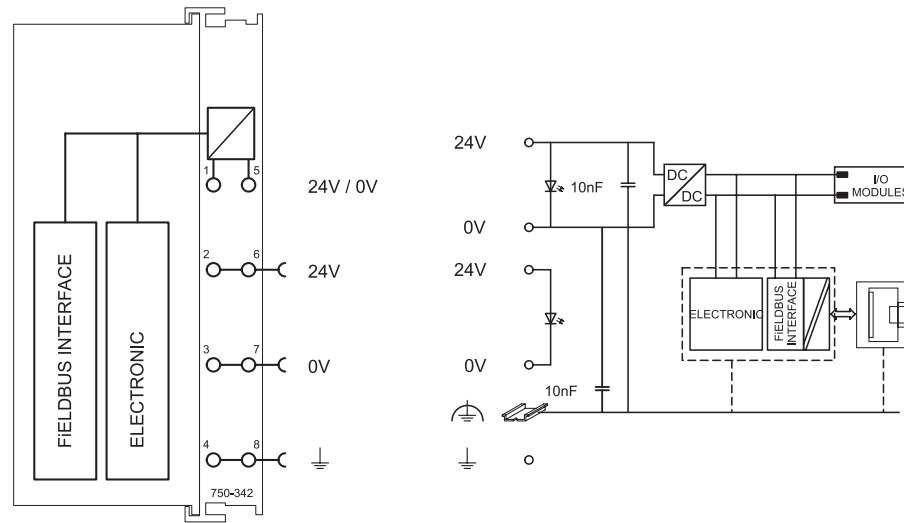

Fig. 3.1-2: Device supply

G034201e

The integrated internal system supply module generates the necessary voltage to supply the electronics and the connected I/O modules.

The fieldbus interface is supplied with electrically isolated voltage from the internal system supply module.

3.1.2.3 Fieldbus connection

Connection to the fieldbus is by an RJ45 connector. A category 5, shielded/unshielded twisted pair cable (S-UTP) with an impedance of 100 Ohm $\pm 15\%$ is mandatory as a connecting line for the 10BaseT Interface. The connection point is physically lowered for the coupler/controller to fit in an 80 mm high switch box once connected.

The electrical isolation between the fieldbus system and the electronics is achieved by means of DC/DC converters and optocouplers in the fieldbus interface.

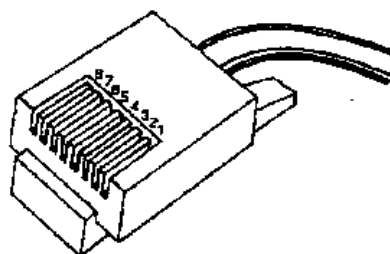

Contact	Signal	
1	TD +	Transmit +
2	TD -	Transmit -
3	RD +	Receive +
4		free
5		free
6	RD -	Receive -
7		free
8		free

Fig. 3.1-3: RJ45-connector and RJ45 connector configuration



Attention!
Only for use in LAN, not for connection to telecommunication circuits!

3.1.2.4 Display elements

The operating condition of the fieldbus coupler or node is signaled via light diodes (LED).

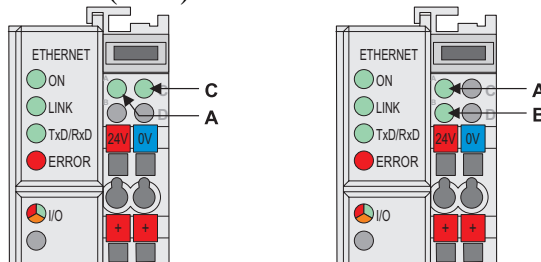

Fig. 3.1-4: Display elements 750-342

g012946x

LED	Color	Meaning
ON	green	Fieldbus initialization is correct
LINK	green	Link to a physical network exists
TxD/RxD	green	Data exchange taking place
ERROR	red	Error on the fieldbus
IO	red /green / orange	The 'I/O'-LED indicates the operation of the node and signals faults encountered
A	green	Status of the operating voltage – system
B or C	green	Status of the operating voltage – power jumper contacts (LED position is manufacturing dependent)

3.1.2.5 Configuration interface

The configuration interface used for the communication with WAGO-I/O-CHECK or for firmware download is located behind the cover flap.

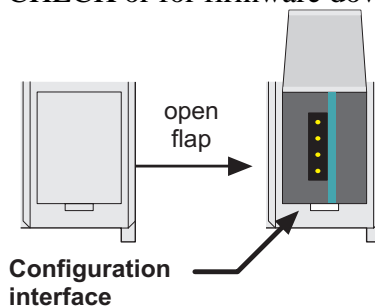

Fig. 3.1-5: Configuration interface

g012945e

The communication cable (750-920) is connected to the 4 pole header.



Warning
The communication cable 750-920 must not be connected or disconnected while the coupler/controller is powered on!

3.1.2.6 Hardware address (MAC-ID)

Each WAGO ETHERNET fieldbus coupler is provided from the factory with a unique and internationally unambiguous physical ETHERNET address, also referred to as MAC-ID (Media Access Control Identity). This address is to be found on the rear of the coupler and on an adhesive tear-off label on the side of the coupler. The address has a fixed length of 6 Bytes (48 Bit) and contains the address type, the manufacturer's ID, and the serial number.

3.1.3 Operating system

Following is the configuration of the master activation and the electrical installation of the fieldbus station to start up the system.

After switching on the supply voltage, the coupler determines the I/O modules and the present configuration.

In the event of a fault, the coupler changes to the "Stop" condition. The "I/O" LED flashes red. After a fault free start up, the coupler changes to the "Fieldbus start" status and the "I/O" LED lights up green.

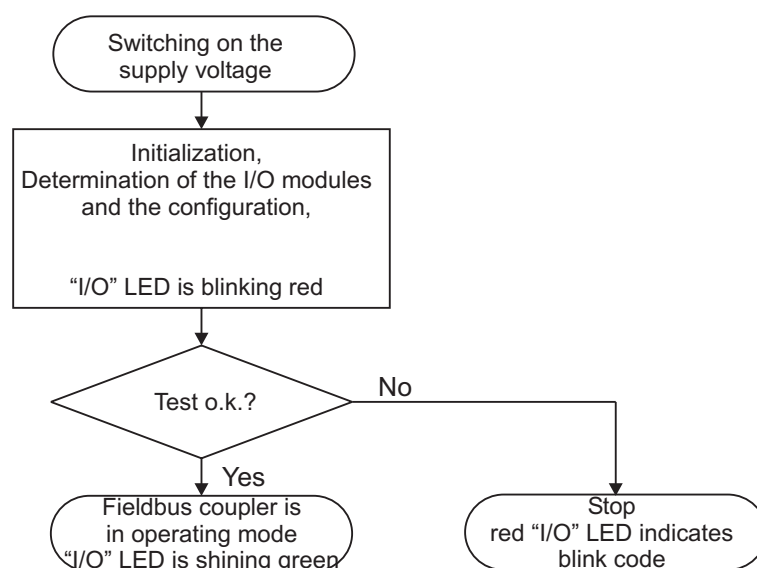

Fig. 3.1-6: Operating system 750-342

g012920e

3.1.4 Process image

After switching on, the coupler recognizes all I/O modules plugged into the node which supply or wait for data (data width/bit width > 0). Analog and digital I/O modules can be mixed on the same node.



Attention

For the number of input and output bits or bytes of the individually activated I/O modules, please refer to the corresponding I/O module description.

The coupler produces an internal process image from the data width and the type of I/O module as well as the position of the I/O modules in the node. It is divided into an input and an output data area.

The data of the digital I/O modules is bit orientated, i.e. the data exchange is made bit for bit. The analog I/O modules are representative for all byte orientated I/O modules, i.e. those where the data exchange is made byte for byte. These I/O modules include for example the counter modules, I/O modules for angle and path measurement as well as the communication modules.

The data of the I/O modules is separate from the local input and output process image in the sequence of their position after the coupler in the individual process image.

First, all the byte oriented bus modules and then the bit oriented bus modules are stored in the process image. The bits of the digital modules are grouped to form bytes. As soon as the number of digital I/O's exceeds 8 bits, the coupler automatically starts the next byte.



Attention

A process image restructuring may result if a node is changed. In this case the process data addresses also change in comparison with earlier ones. In the event of adding modules, take the process data of all previous modules into account.

The coupler provides a storage area of 256 words each (word 0 - 255) for the physical input and output data.

Access from the fieldbus side is fieldbus specific. For the ETHERNET TCP/IP fieldbus coupler, a MODBUS/TCP master accesses the data via implemented MODBUS functions. Here decimal and/or hexadecimal MODBUS addresses are used.



More information

A detailed description of these fieldbus-specific data access operations is given in the section "MODBUS functions".



More Information

You can find the fieldbus specific process data architecture for all I/O Modules in the chapter „Fieldbus specific Process Data Architecture“.

3.1.4.1 Example of a process input image

The following figure is an example of a process input image. The configuration comprises of 16 digital and 8 analog inputs. The process image thus has a data length of 8 words for the analog and 1 word for the digital inputs, i.e. 9 words in total.

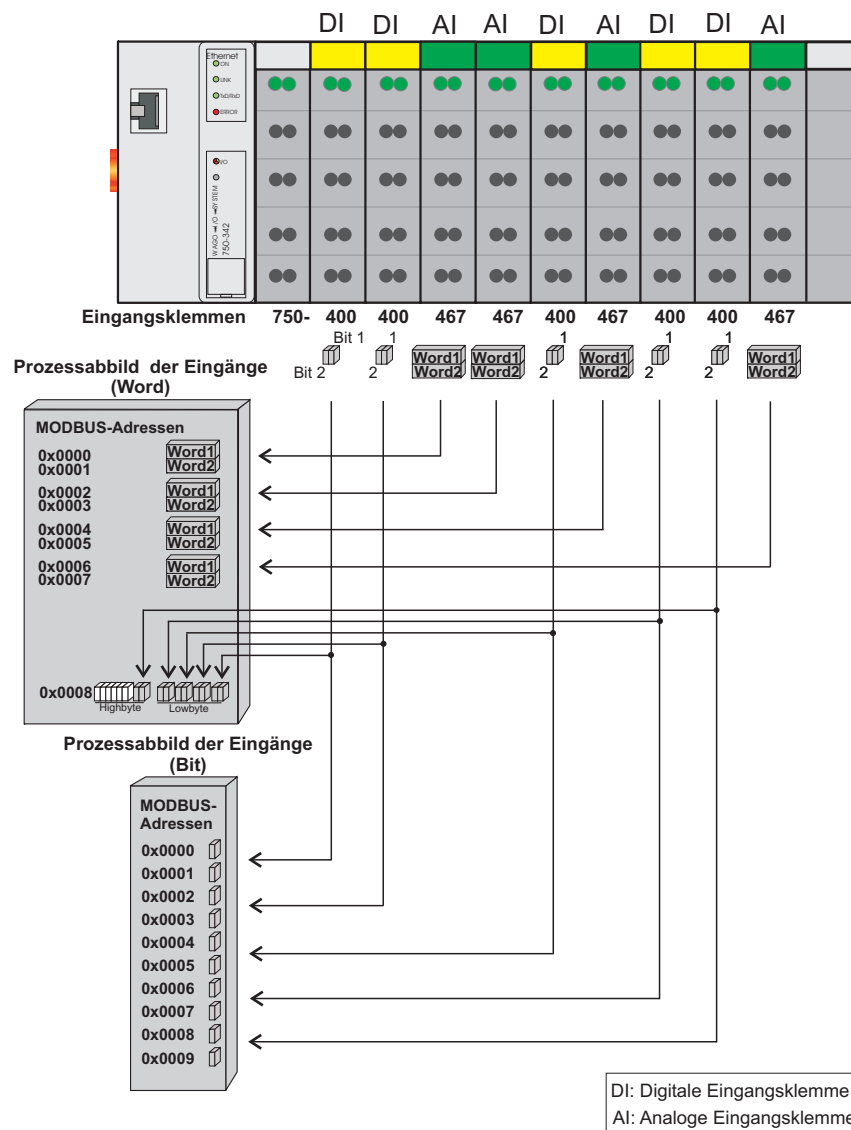

Fig. 3.1-7: Example of a process input image

G012914e

3.1.4.2 Example of a process output image

The following example for the process output image comprises of 2 digital and 4 analog outputs.

It comprises of 4 words for the analog and 1 word for the digital outputs, , i.e. 5 words in total.

In addition, the output data can be read back by means of an offset of 200hex (0x0200) added to the MODBUS address.

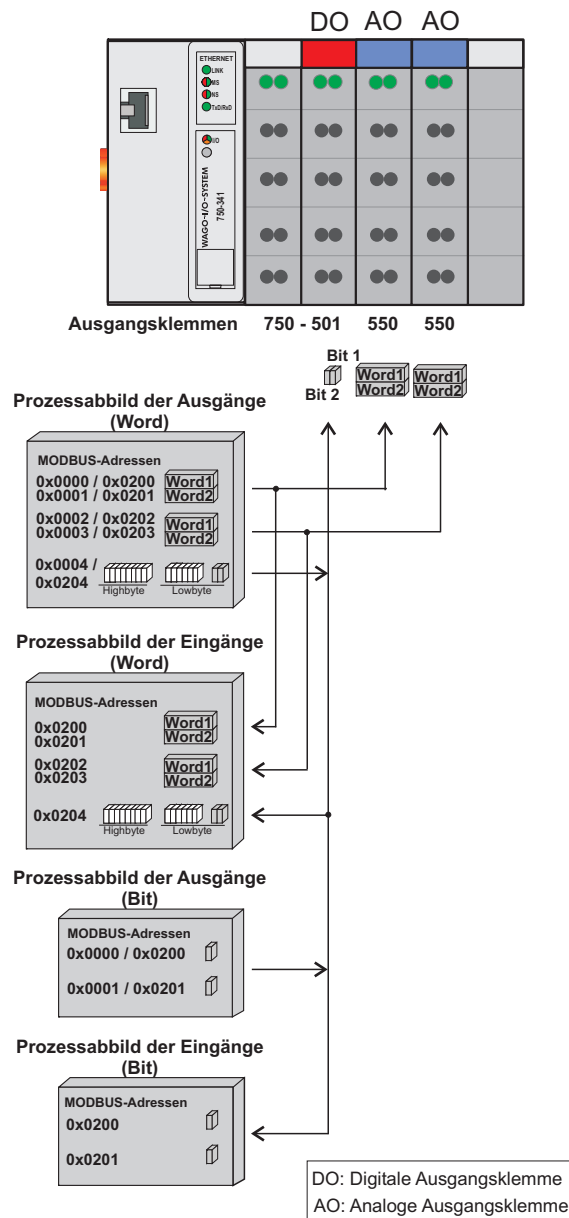

Fig. 3.1-8: Example of a process output image

G015015e

3.1.4.3 Process Data Architecture

With some I/O modules, the structure of the process data is fieldbus specific. In the case of an Ethernet TCP/IP coupler/controller, the process image uses a word structure (with word alignment). The internal mapping method for data greater than one byte conforms to the Intel format.



More Information

You can find the fieldbus specific process data architecture for all I/O Modules of the WAGO-I/O-SYSTEM 750 and 753 in the chapter „ Process Data Architecture for ETHERNET“.

3.1.5 Data Exchange

Process data exchange with the ETHERNET TCP/IP fieldbus coupler occurs via the MODBUS/TCP protocol.

MODBUS/TCP works according to the master/slave principle. The master is a superimposed control unit, i.e. a PC or a PLC device. The ETHERNET TCP/IP couplers of the **WAGO-I/O-SYSTEM** are slave devices.

The master makes a query for communication. Through addressing, this query can be sent to a specific node. The nodes receive the query and return a response to the master, depending on the kind of query.

A coupler can communicate with a certain number of simultaneous connections (socket connections) to other network subscribers:

- 1 connection for HTTP (reading HTML pages from coupler) and
- 5 connections via MODBUS/TCP (reading or writing input and output data from coupler).

The maximum number of simultaneous connections cannot be exceeded. If further connections are to be made, terminate existing connections beforehand.

For a data exchange, the ETHERNET TCP/IP fieldbus coupler is equipped with two interfaces:

- the interface to fieldbus (-master) and
- the interface to the bus modules.

Data exchange takes place between MODBUS master and the bus modules. The master accesses the bus module data via implemented MODBUS functions.

3.1.5.1 Memory areas

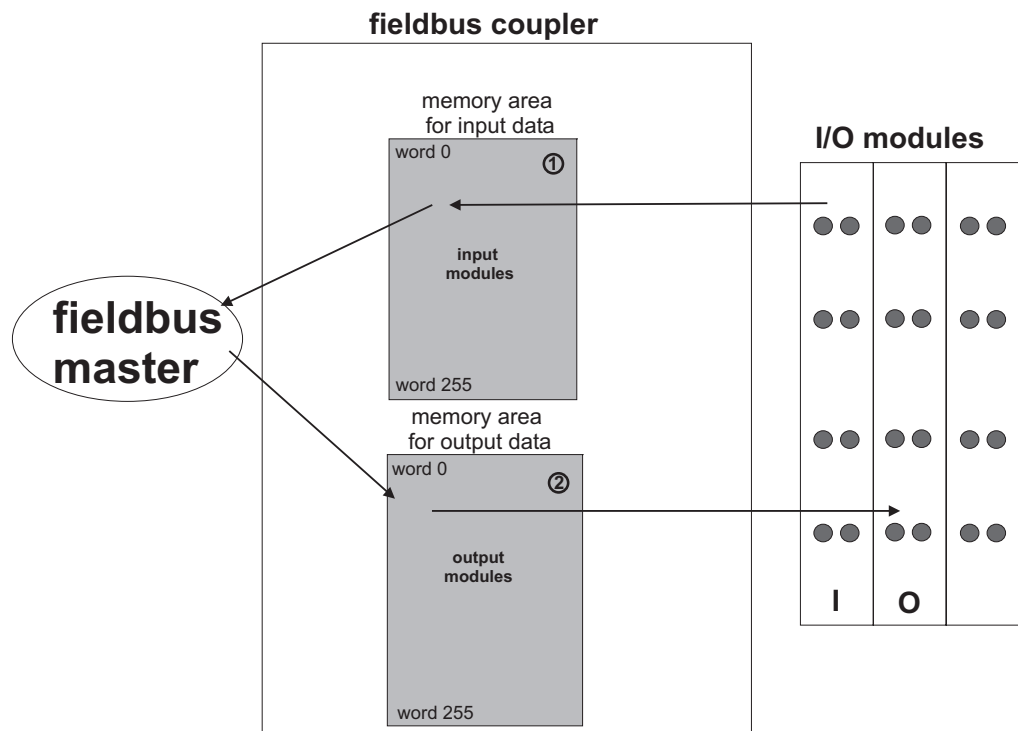

Fig. 3.1-9: Memory areas and data exchange for a fieldbus coupler

g012939e

The coupler process image contains the physical data of the bus modules in a storage area for input data and in a storage area for output data (word 0 ... 255 each).

- (1) The input module data can be read from the fieldbus side.
- (2) In the same manner, writing on the output modules is possible from the fieldbus side.

In addition, all output data of the ETHERNET TCP/IP coupler are mirror imaged on a storage area with the address offset 0x0200. This allows to read output values back by adding 0x0200 to the MODBUS address.

3.1.5.2 Addressing

3.1.5.2.1 Addressing the I/O modules

The arrangement of the I/O modules in a node is optional.

When addressing, first of all the more complex modules (modules occupying 1 or more bytes) are taken into account in accordance with their physical order behind the fieldbus coupler. As such, they occupy the addresses starting with word 0.

Following this, the data of the other modules (modules occupying less than 1 byte) follow, grouped into bytes. In accordance with the physical byte-wise order this data is used to fill up the bytes. As soon as a full byte is occupied by the bit-oriented modules, the next byte is automatically started.



Attention

For the number of input and output bits and/or bytes of the individual activated bus modules, please refer to the pertaining descriptions of the bus modules.



Attention

Once a node is modified, a new architecture of the process image can result. As such, the address of the process data will also change. In the event of adding modules, the process data of all previous modules has to be taken into account.

Data width \geq 1 Word / channel	Data width = 1 Bit / channel
Analog input modules	Digital input modules
Analog output modules	Digital output modules
Input modules for thermal elements	Digital output modules with diagnosis (2 Bit / channel)
Input modules for resistance sensors	Power supply modules with fuse holder / diagnosis
Pulse width output modules	Solid State power relay
Interface module	Relay output modules
Up/down counter	
I/O modules for angle and path measurement	

Table 3.1.1: I/O module data width

3.1.5.3 Data exchange between MODBUS/TCP master and I/O modules

The data exchange between the MODBUS/TCP master and the I/O modules is made by the implemented MODBUS functions in the coupler with reading and writing in bits or bytes.

The controller handles four different types of process data:

- Input words
- Output words
- Input bits
- Output bits

The word for word access to the digital input and output modules is made in accordance with the following table:

Digital Inputs/Outputs	16.	15.	14.	13.	12.	11.	10.	9.	8.	7.	6.	5.	4.	3.	2.	1.
Process data word	Bit 15	Bit 14	Bit 13	Bit 12	Bit 11	Bit 10	Bit 9	Bit 8	Bit 7	Bit 6	Bit 5	Bit 4	Bit 3	Bit 2	Bit 1	Bit 0
Byte	High-Byte D1								Low-Byte D0							

Table 3.1.2: Allocation of digital inputs/outputs to process data word acc. Intel format

The outputs can be read back by adding 0x0200 to the MODBUS address.

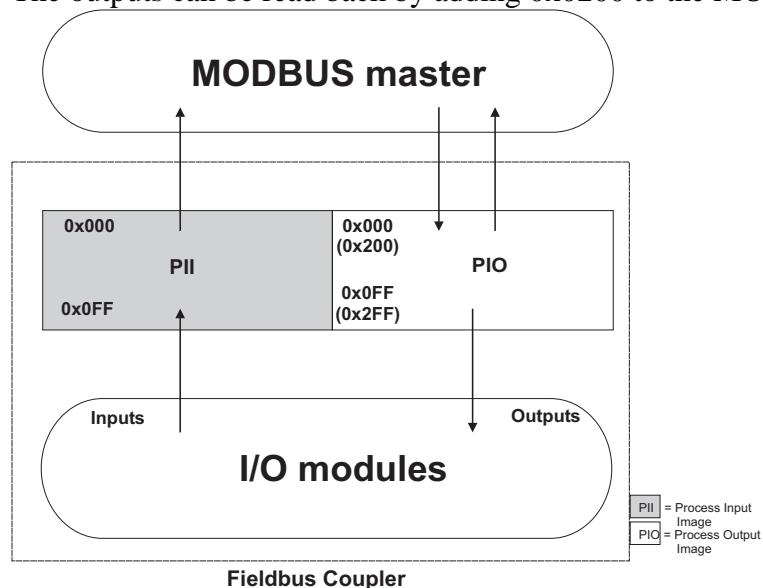

Fig. 3.1-10: Data exchange between the MODBUS master and I/O modules

g012927e

Starting from address 0x1000 there are the register functions. The register functions made available in the coupler, can be addressed by the MODBUS master along with the implemented MODBUS function codes (read/write). To this effect, the individual register address is entered in place of the address of a module channel.



More information

You can find a detailed description of the MODBUS addressing in the chapter „MODBUS Register Mapping“.

3.1.6 Starting up a Fieldbus Node

This chapter shows the step-by-step procedure for starting up a WAGO ETHERNET TCP/IP fieldbus node. The following also contains a description of how to read out the coupler-internal HTML pages.



Attention

This description is given as an example and is limited to the execution of a local startup of an individual ETHERNET fieldbus node with a computer running under windows which is not connected to a network.

Direct Internet connection should only be performed by an authorized network administrator and is, therefore, not described in this manual.

The procedure contains the following steps:

1. Noting the MAC-ID and establishing the fieldbus node
2. Connecting the PC and fieldbus node
3. Determining the IP address
4. Allocation of the IP address to the fieldbus node
5. Function of the fieldbus tests
6. Reading out information as HTML pages

3.1.6.1 Note the MAC-ID and establish the fieldbus node

Before establishing your fieldbus node, please note the hardware address (MAC-ID) of your ETHERNET fieldbus coupler.

This is located on the rear of the fieldbus coupler and on the self-adhesive tear-off label on the side of the fieldbus coupler.

MAC-ID of the fieldbus coupler will be in this format:

3.1.6.2 Connecting PC and fieldbus node

Connect the assembled ETHERNET TCP/IP fieldbus node via a hub or directly to the PC using a 10Base-T cable.



Attention

For a direct connection, a crossover cable is required instead of a parallel cable.

Now start the PC, functioning as master and BootP server, and switch on the voltage supply on the fieldbus coupler (DC 24 V power pack). Once the operating voltage has been switched on, the initialization starts. The fieldbus coupler determines the configuration of the bus modules and creates the process image.

During the startup the 'I/O' LED (Red) flashes at high frequency.

When the 'I/O' LED and the 'ON' LED light up green, the fieldbus coupler is ready for operation.

If an error has occurred during startup, it is indicated as an error code by the 'I/O'-LED flashing (red).



Note

The IP address can be allocated under other operating systems (i.e. under Linux) as well as with any other BootP servers.



Attention

The IP address can be allocated in a direct connection via a crossover cable or via a parallel cable and a hub. An allocation over a switch is not possible.

BootP table



Attention

Prerequisite for the following steps is the correct installation of the WAGO BootP server.

1. Go to the **Start menu**, menu item **Programs / WAGO Software / WAGO BootP Server** and click on **WAGO BootP Server configuration**.

An editable table will appear: "bootptab.txt".

This table displays the data basis for the BootP server. Directly following the list of all notations used in the BootP table there are two examples for the allocation of an IP address.

"Example of entry with no gateway" and **"Example of entry with gateway"**.

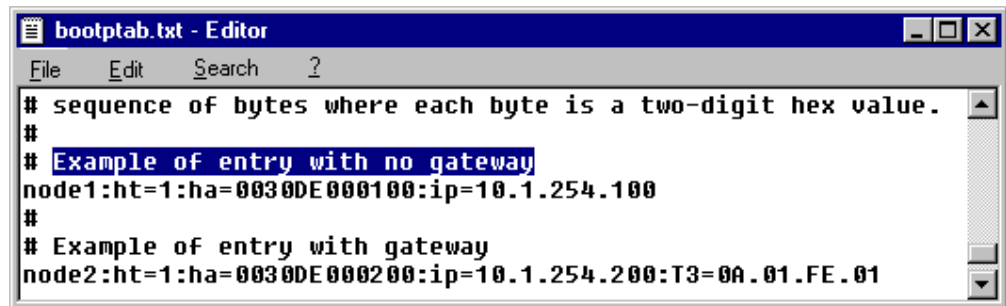

Fig. 3.1-11: BootP table

p012908e

The examples mentioned above contain the following information:

Declaration	Meaning
node1, node2	Any name can be given for the node here.
ht=1	Specify the hardware type of the network here. The hardware type for ETHERNET is 1. (The numbers are described in <i>RFC1700</i>)
ha=0030DE000100 ha=0030DE000200	Specify the hardware address or the MAC-ID of the ETHERNET fieldbus coupler (hexadecimal).
ip= 10.1.254.100 ip= 10.1.254.200	Enter the IP address of the ETHERNET fieldbus coupler (decimal) here.
T3=0A.01.FE.01	Specify the gateway IP address here. Write the address in hexadecimal form.
sm=255.255.0.0	In addition enter the Subnet-mask of the subnet (decimal), where the ETHERNET fieldbus coupler belongs to.

No gateway is required for the local network described in this example. Therefore, the first example: "**Example of entry with no gateway**" can be used.

2. Move the mouse pointer to the text line:
"node1:ht=1:ha=0030DE000100:ip=10.1.254.100" and mark the 12 character hardware address which is entered after ha=...
Enter the MAC-ID of your own network coupler.
3. If you want to give your fieldbus node a name, delete the name "node1" and enter any name in its place.
4. To assign the coupler a desired IP address, mark the IP address specified in the example which is entered after ip=...
Replace it with the IP address you have selected.
5. Because the second example is not necessary at present, insert a "#" in front of the text line of the second example: "# node2:hat=1:ha=003 0DE 0002 00:ip=10.1.254.200:T3=0A.01.FE.01", so that this line will be ignored.



Note

To address more fieldbus nodes, enter a corresponding text line showing the corresponding entries for each node.

6. Save the altered settings in this text file "bootptab.txt". To do this go to the **File** menu, menu item **Save**, and close the editor.

BootP Server

7. Now open the dialog window for the WAGO BootP server by going to the Start menu on your screen surface, menu item Program / WAGO Software / WAGO BootP Server and click on WAGO BootP Server.
8. Click on the "Start" button in the opened dialog window.
This will activate the inquiry/response mechanism of the BootP protocol. A series of messages will be displayed in the BootP server. The error messages indicate that some services (i.e. port 67, port 68) in the operating system have not been defined.

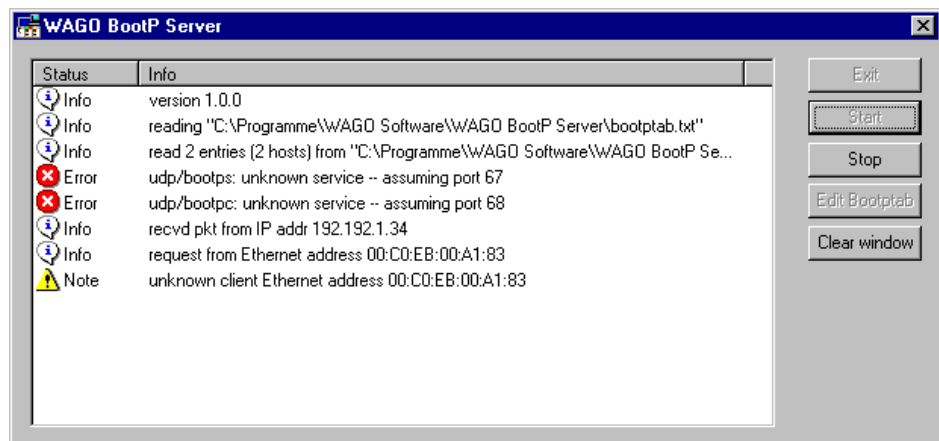

Fig. 3.1-12: Dialog window of the WAGO BootP server with messages

g012909d

9. Now it is important to restart the coupler by resetting the hardware . This ensures that the new IP address will be accepted by the coupler.
To do this, cycle power to the fieldbus coupler for approx. 2 seconds.

Following this, the IP address in the coupler is permanently stored and maintained even once the coupler is removed or following a longer voltage failure.

10. Subsequently, click on the "Stop" button and then on the "Exit" button, to close the BootP Server again.

3.1.6.5 Testing the function of the fieldbus node

1. To test the communication with the coupler and the correct assignment of the IP address call up the DOS prompt under **Start menu / Program / MS-DOS Prompt**.
2. Enter the command: "**ping**" with the IP address you have assigned in the following form:
ping [space] XXXX . XXXX . XXXX . XXXX (=IP address).
Example: ping 10.1.254.202

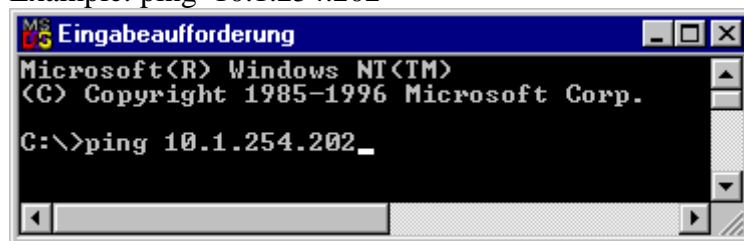

Fig. 3-13: Example for the function test of a fieldbus node

P012910d

3. When the Return key has been pressed, your PC will receive a response from the coupler, which will then be displayed in the DOS prompt.
If the error message: "Timeout" appears instead, please compare your entries again to the allocated IP address.
4. When the test has been performed successfully, you can close the DOS prompt.
The network node has now been prepared for communication.

3.1.6.6 Reading out the information as HTML pages

The information saved in the fieldbus coupler can be read as an HTML page using a web browser.

- Information on the fieldbus node (Terminal Status):
 - Number of digital, analog or complex modules
 - Representation of the process image
- Information on the fieldbus coupler (Coupler and Network Details):
 - Order number
 - Firmware version
 - MAC-ID
 - IP address
 - Gateway address (if applicable)
 - Subnet mask
 - Number of transmitted and received packets
- Diagnostic information on the fieldbus coupler (Coupler Status):
 - Error code
 - Error argument
 - Error description

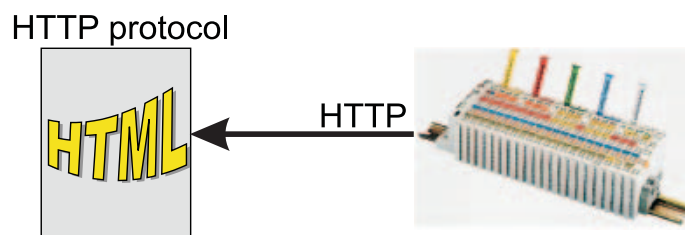

Fig. 3-14: Reading out the information via the HTTP protocol

G012916d

Please proceed as follows:

1. Open a web browser such as Microsoft Internet-Explorer, Netscape Navigator, ...
2. Simply enter the IP address of your fieldbus node in the address field of the browser and press the Return key.
The first HTML page with the information on your fieldbus coupler will be displayed in the browser window. Use the hyperlinks to find out more information.



Attention

If the pages are not displayed after local access to the fieldbus node, then define in your web browser that, as an exception, no proxyserver is to be used for the IP address of the node.

3.1.7 LED Display

The coupler possesses several LED's for displaying the coupler operating status and the complete node status.

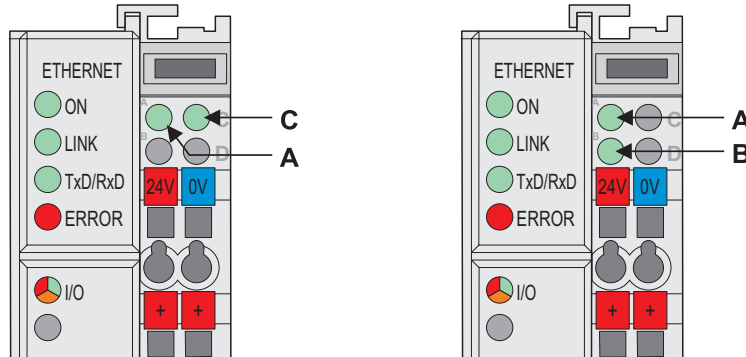

Fig. 3-15: Display elements 750-342

G012946x

The LEDs can be divided into three groups.

The first group of LEDs display the status of the Ethernet fieldbus. It contains the solid color LEDs, labelled as: 'ON' (green), 'LINK' (green), 'TxD/RxD' (green) and 'ERROR' (red).

The second group of LEDs is a three-color LED (red/green/orange). This LED is labelled 'I/O', and displays the status of the internal bus and i. e. the status of the fieldbus node.

The third group uses solid colored green LEDs. They are located on the right-hand side of the coupler power supply. These display the status of the supply.

3.1.7.1 Fieldbus status

The operating status of the communication via ETHERNET is signalled by means of the top LED group (ON, LINK, TxD/RxD and ERROR).

LED	Meaning	Trouble shooting
ON		
green	Fieldbus initialization is correct	
OFF	Fieldbus initialization is not correct, no function or self-test	Check the supply voltage (24V and 0V), check the IP configuration
LINK		
green	Link to a physical network exists	
OFF	No link to a physical network	Check the fieldbus connection.
TxD/RxD		
green	Data exchange taking place	
OFF	No data exchange	
ERROR		
red	Error on the fieldbus	
OFF	No error on the fieldbus, normal operation	

3.1.7.2 Node status – Blink code from the 'I/O' LED

The 'I/O'-LED displays the communication status of the internal bus. Additionally, this LED is used to display fault codes (blink codes) in the event of a system error.

LED	Meaning	Trouble shooting
I/O		
Green	Fieldbus coupler operating perfectly	
Red	a) During startup of fieldbus coupler: Internal bus being initialized, Startup displayed by LED flashing fast for approx. 1-2 seconds	
Red	b) After startup of fieldbus coupler: Errors, which occur, are indicated by three consecutive flashing sequences. There is a short pause between each sequential flash.	Evaluate the fault message (fault code and fault argument).

The coupler starts up after switching on the supply voltage. The "I/O" LED blinks. The "I/O" LED has a steady light following a fault free run-up. In the case of a fault the "I/O" LED continues blinking. The fault is cyclically displayed by the blink code.

Detailed fault messages are displayed with the aid of a blink code. A fault is cyclically displayed with up to 3 blink sequences.

- The first blink sequence (approx. 10 Hz) starts the fault display.
- The second blink sequence (approx. 1 Hz) following a pause. The number of blink pulses indicates the **fault code**.
- The third blink sequence (approx. 1 Hz) follows after a further pause. The number of blink pulses indicates the **fault argument**.

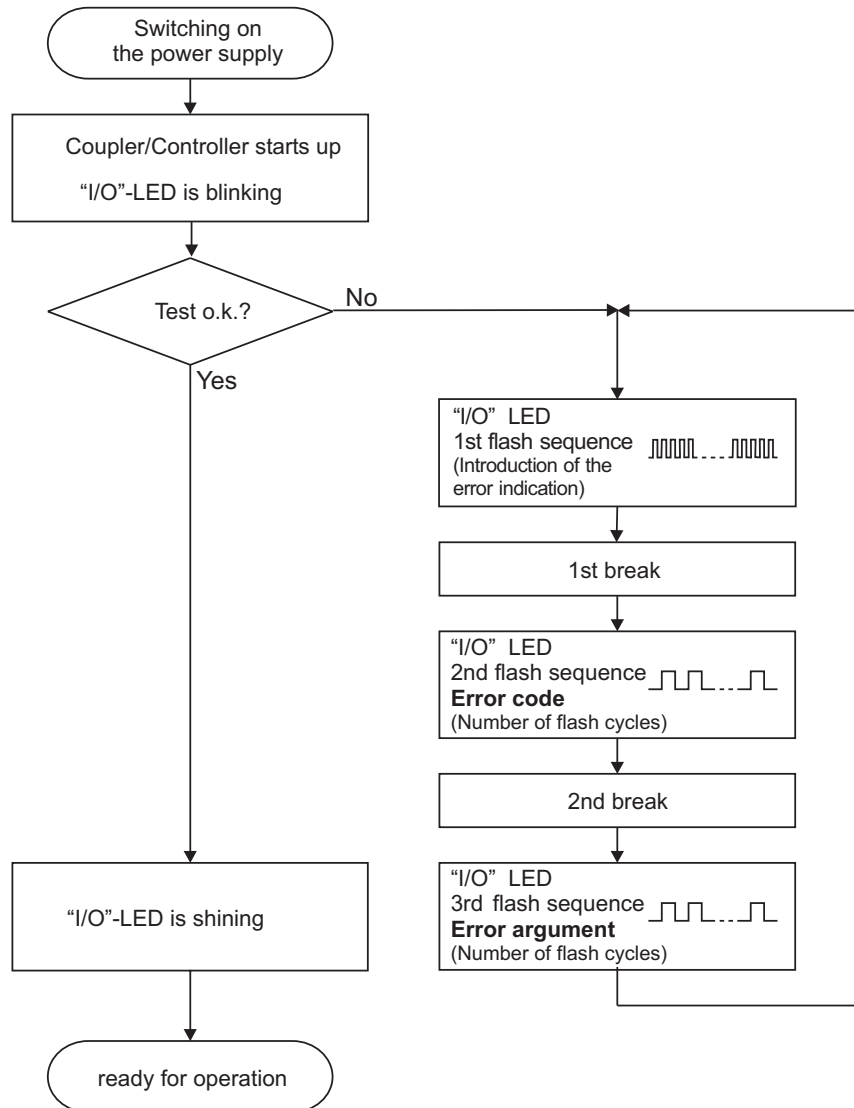

Fig. 3.1-16: Signalling of the LED for indication of the node status

g012911e

After clearing a fault, restart the coupler by cycling the power.

Fault message of the 'I/O'-LED

1 st flash sequence: Start of the Fault message

2 nd flash sequence: Fault code

3 rd flash sequence: Fault argument

Fault code 1: "Hardware and Configuration fault"		
Fault argument	Fault description	Trouble shooting
-	Invalid checksum within the parameter range of fieldbus coupler	Turn off the power supply of the node, exchange the bus coupler and turn the power supply on again.
1	Overflow of the internal buffer memory for the inline code	Turn off the power supply of the node, reduce number of I/O modules and turn the power supply on again. If the error still exists, exchange the bus coupler.
2	I/O module(s) with unsupported data type	Detect faulty I/O module as follows: turn off the power supply. Place the end module in the middle of the fieldbus node. Turn the power supply on again. – If the LED is still blinking, turn off the power supply and place the end module in the middle of the first half of the node (towards the coupler). – If the LED doesn't blink, turn off the power supply and place the end module in the middle of the second half of the node (away from the coupler). Turn the power supply on again. Repeat this procedure until the faulty I/O module is detected. Replace the faulty I/O module. Ask about a firmware update for the fieldbus coupler.
3	Unknown program module type of the flash program memory	Turn off the power supply of the node, exchange the bus coupler and turn the power supply on again.
4	Fault when writing data within the flash memory	Turn off the power supply of the node, exchange the bus coupler and turn the power supply on again.
5	Fault when deleting a flash sector	Turn off the power supply of the node, exchange the bus coupler and turn the power supply on again.
6	Changed I/O module configuration determined after AUTORESET	Restart the fieldbus coupler by turning the power supply off and on again.

7	Fault when writing data in the serial EEPROM	Turn off the power supply of the node, exchange the bus coupler and turn the power supply on again.
8	Invalid Hardware Firmware combination	Turn off the power supply of the node, exchange the bus coupler and turn the power supply on again.
9	Invalid checksum within the serial EEPROM	Turn off the power supply of the node, exchange the bus coupler and turn the power supply on again.
10	serial EEPROM initialization fault	Turn off the power supply of the node, exchange the bus coupler and turn the power supply on again.
11	Fault when reading out data from the EEPROM	Turn off the power supply of the node, exchange the bus coupler and turn the power supply on again.
12	Timeout when writing data in the EEPROM	Turn off the power supply of the node, exchange the bus coupler and turn the power supply on again.
13	- not used -	
14	Maximum number of Gateway or Mailbox I/O modules exceeded	Turn off the power supply of the node, reduce number of Gateway or Mailbox I/O modules and turn the power supply on again.
Fault code 2 -not used-		
Fault argument	Fault description	Trouble shooting
-	not used	-

Fault code 3: "Internal bus protocol fault"		
Fault argument	Fault description	Trouble shooting
-	Internal bus communication malfunction; faulty device can't be detected	<p>If the fieldbus node comprises internal system supply modules (750-613), make sure first that the power supply of these modules is functioning. This is indicated by the status LEDs. If all I/O modules are connected correctly or if the fieldbus node doesn't comprise 750-613 modules you can detect the faulty I/O module as follows: turn off the power supply of the node. Place the end module in the middle of the fieldbus node. Turn the power supply on again.</p> <ul style="list-style-type: none"> – If the LED is still blinking, turn off the power supply and place the end module in the middle of the first half of the node (towards the coupler). – If the LED doesn't blink, turn off the power supply and place the end module in the middle of the second half of the node (away from the coupler). <p>Turn the power supply on again. Repeat this procedure until the faulty I/O module is detected. Replace the faulty I/O module. If there is only one I/O module left but the LED is still blinking, then this I/O module or the coupler is defective. Replace defective component.</p>

Fault code 4: "Internal bus physical fault"		
Fault argument	Fault description	Trouble shooting
-	Error in internal bus data communication or interruption of the internal bus at the coupler	<p>Turn off the power supply of the node. Place an I/O module with process data behind the coupler and note the error argument after the power supply is turned on. If no error argument is given by the I/O LED, replace the coupler. Otherwise detect faulty I/O module as follows: turn off the power supply. Place the end module in the middle of the fieldbus node. Turn the power supply on again.</p> <p>– If the LED is still blinking, turn off the power supply and place the end module in the middle of the first half of the node (towards the coupler).</p> <p>– If the LED doesn't blink, turn off the power supply and place the end module in the middle of the second half of the node (away from the coupler).</p> <p>Turn the power supply on again. Repeat this procedure until the faulty I/O module is detected. Replace the faulty I/O module. If there is only one I/O module left but the LED is still blinking, then this I/O module or the coupler is defective. Replace defective component.</p>
n*	Interruption of the internal bus after the n th process data module.	Turn off the power supply of the node, exchange the (n+1) th process data module and turn the power supply on again.
Fault code 5: "Internal bus initialization fault"		
Fault argument	Fault description	Trouble shooting
n*	Error in register communication during internal bus initialization	Turn off the power supply of the node and replace n th process data module and turn the power supply on again.

Fault code 6: "Fieldbus specific faults"		
Fault argument	Fault description	Trouble shooting
1	No BootP server reply	Check the settings of BootP server.
2	Not identified ETHERNET coupler	Turn off the power supply of the node, exchange fieldbus coupler and turn the power supply on again.
3	Invalid MACID	Turn off the power supply of the node, exchange fieldbus coupler and turn the power supply on again.
4	TCP/IP initialization error	Restart the fieldbus coupler by turning the power supply off and on again. If the error still exists, exchange the bus coupler.
Fault code 7 -not used-		
Fault argument	Fault description	Trouble shooting
-	not used	-
Fault code 8 -not used-		
Fault argument	Fault description	Trouble shooting
-	not used	-
Fault code 9 "CPU Trap Error"		
Fault argument	Fault description	Trouble shooting
1	Illegal Opcode	Error in the program sequence. Contact the WAGO I/O-Support
2	Stack overflow	
3	Stack underflow	
4	NMI	

* The number of blink pulses (n) indicates the position of the I/O module. I/O modules without data are not counted (e.g. supply module without diagnosis)

Example for a fault message; Fault: The 13th I/O module has been removed	
1.	The "I/O" LED starts the fault display with the first blink sequence (approx. 10 flashes/second).
2.	The second blink sequence (1 flash/second) follows the first pause. The "I/O" LED blinks four times and thus signals the fault code 4 (internal bus data fault).
3.	The third blink sequence follows the second pause. The "I/O" LED blinks twelve times. The fault argument 12 means that the internal bus is interrupted after the 12th I/O module.

3.1.7.3 Supply voltage status

There are two green LED's in the coupler supply section to display the supply voltage. The left LED (A) indicates the 24 V supply for the coupler. The right hand LED (B or C) signals the supply to the field side, i.e. the power jumper contacts.

LED	Meaning	Trouble shooting
A		
green	Operating voltage for the system exists.	
OFF	No operating voltage for the system.	Check the supply voltage (24V and 0V).
B or C		
green	Operating voltage for the power jumper contacts exists.	
OFF	No operating voltage for the the power jumper contacts.	Check the supply voltage (24V and 0V).

3.1.8 Fault behavior

3.1.8.1 Fieldbus failure

A field bus failure is given i. e. when the master cuts-out or the bus cable is interrupted. A fault in the master can also lead to a fieldbus failure.

A field bus failure is indicated when the red "ERROR"-LED is illuminated.

If the watchdog is activated, the fieldbus coupler firmware evaluates the watchdog-register in the case of fault free communication, and the coupler answers all following MODBUS TCP/IP requests with the exception code 0x0004 (Slave Device Failure).



More information

For detailed information on the Watchdog register see Chapter "MODBUS Functions"; "Watchdog (Fieldbus failure)".

3.1.8.2 Internal bus fault

An internal bus fault is created, for example, if an I/O module is removed. If this fault occurs during operation the output modules behave in the same manner as an I/O module stop. The "I/O" LED blinks red.











The coupler generates a fault message (fault code and fault argument).

After clearing the internal bus fault, restart the coupler by cycling the power.

The coupler starts up. The transfer of the process data is then resumed and the node outputs are correspondingly set.

3.1.9 Technical Data

System data	
Number of nodes	limited by ETHERNET specification
Transmission medium	Twisted Pair S-UTP 100 Ω cat. 5
Buscoupler connection	RJ45
Max. length of fieldbus segment	100 m between hub station and 750-342; max. length of network limited by ETHERNET specification
Baud rate	10 Mbit/s
Protocols	MODBUS/TCP, MODBUS/UDP, HTTP, BootP
Technical Data	
No. of I/O modules with bus extension	64 250
Fieldbus Input process image max. Output process image max.	max. 512 Byte max. 512 Byte
Configuration	via PC
Max. no. of socket connections	1 HTTP, 5 MODBUS/TCP
Voltage supply	DC 24 V (-25 % ... + 30 %)
Input currentmax	500 mA at 24 V
Efficiency of the power supply	87 %
Internal current consumption	200 mA at 5 V
Total current for I/O modules	1800 mA at 5 V
Isolation	500 V system/supply
Voltage via power jumper contacts	DC 24 V (-25 % ... + 30 %)
Current via power jumper contactsmax	DC 10 A
Dimensions (mm) W x H x L	51 x 65* x 100 (*from upper edge of DIN 35 rail)
Weight	ca. 195 g
Accessories	
Miniature WSB quick marking system	
Standards and Regulations (cf. Chapter 2.2)	
EMC CE-Immunity to interference	acc. to EN 50082-2 (96)
EMC CE-Emission of interference	acc. to EN 50081-1 (93)
EMC marine applications-Immunity to interference	acc. to Germanischer Lloyd (1997)
EMC marine applications-Emission of interference	acc. to Germanischer Lloyd (1997)
Approvals (cf. Chapter 2.2)	

	cUL _{US} (UL508)	
	ABS (American Bureau of Shipping) ¹⁾	
	BV (Bureau Veritas) ¹⁾	
	DNV (Det Norske Veritas) ¹⁾	Cl. B
	GL (Germanischer Lloyd) ¹⁾	Cat. A, B, C, D
	KR (Korean Register of Shipping) ¹⁾	
	LR (Lloyd's Register) ¹⁾	Env. 1, 2, 3, 4
NKK	NKK (Nippon Kaiji Kyokai) ¹⁾	
	RINA (Registro Italiano Navale) ¹⁾	
	cUL _{US} (UL1604)	Class I Div2 ABCD T4A
	DEMKO	II 3 G EEx nA II T4
	Conformity Marking	
¹⁾ Consider chapter: „Supplementary power supply regulations”!		

4 Fieldbus Communication

4.1 ETHERNET

4.1.1 General

ETHERNET is a technology, which has been proven and established as an effective means of data transmission in the field of information technology and office communication. Within a short time ETHERNET has also made a successful breakthrough in the area of private PC networks throughout the world.

This technology was developed in 1972 by Dr. Robert M. Metcalfe, David R. Boggs, Charles Thacker, Butler W. Lampson, and Xerox (Stanford, Ct.). Standardization (IEEE 802.3) took place in 1983.

ETHERNET predominantly uses coaxial cables or twisted pair cables as a transmission medium. Connection to ETHERNET, often already existing in networks, (LAN, Internet) is easy and the data exchange at a transmission rate of 10 Mbps or for some couplers/controllers also 100 Mbps is very fast.

ETHERNET has been equipped with higher level communication software in addition to standard IEEE 802.3, such as TCP/IP (Transmission Control Protocol / Internet Protocol) to allow communication between different systems. The TCP/IP protocol stack offers a high degree of reliability for the transmission of information.

In the ETHERNET based (programmable) fieldbus couplers and controllers developed by WAGO, usually various application protocols have been implemented on the basis of the TCP/IP stack.

These protocols allow the user to create applications (master applications) with standardized interfaces and transmit process data via an ETHERNET interface.

In addition to a series of management and diagnostic protocols, fieldbus specific application protocols are implemented for control of the module data, depending upon the coupler or controller, e. g. MODBUS TCP (UDP), EtherNet/IP, BACnet, KNXNET/IP, PROFINET, Powerlink, Sercos III or others.

Information such as the fieldbus node architecture, network statistics and diagnostic information is stored in the ETHERNET (programmable) fieldbus couplers and controllers and can be viewed as HTML pages via a web browser (e.g., Microsoft Internet-Explorer, Netscape Navigator) being served from the HTTP server in the couplers and controllers.

Furthermore, depending on the requirements of the respective industrial application, various settings such as selection of protocols, TCP/IP, internal clock and security configurations can be performed via the web-based management system. However, you can also load web pages you have created yourself into the couplers/controllers, which have an internal file system, using FTP.

The WAGO ETHERNET TCP/IP fieldbus node does not require any additional master components other than a PC with a network card. So, the fieldbus node can be easily connected to local or global networks using the fieldbus connection. Other networking components such as hubs, switches or repeaters can also be used. However, to establish the greatest amount of “determinism” a switch is recommended.

The use of ETHERNET as a fieldbus allows continuous data transmission between the plant floor and the office. Connection of the ETHERNET TCP/IP fieldbus node to the Internet even enables industrial processing data for all types of applications to be called up world-wide. This makes site independent monitoring, visualization, remote maintenance and control of processes possible.

4.1.2 Network Architecture – Principles and Regulations

A simple ETHERNET network is designed on the basis of one PC with a network interface card (NI), one crossover connection cable (if necessary), one ETHERNET fieldbus node and one 24 V DC power supply for the coupler/controller voltage source.

Each fieldbus node consists of a (programmable) fieldbus coupler or controller and a number of needed I/O modules.

Sensors and actuators are connected to the digital or analog I/O modules on the field side. These are used for process signal acquisition or signal output to the process, respectively.

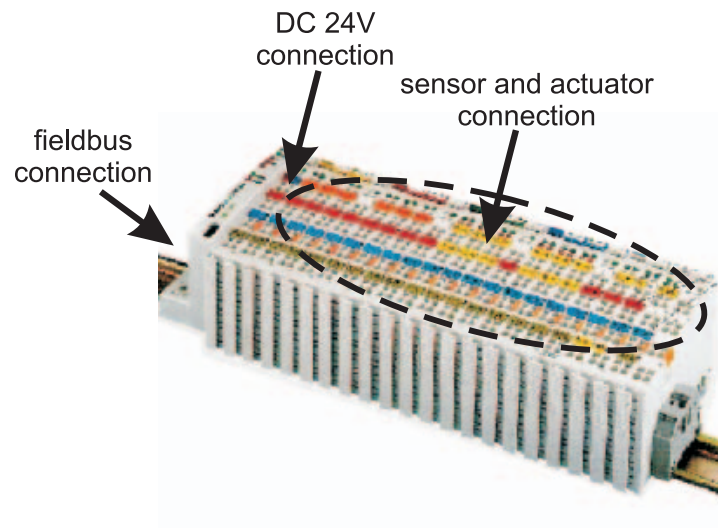

Fig. 4-1. Connection Example and Principle of a Fieldbus Node for a Network Architecture
I1Netzwerknotene

Fieldbus communication between master application and (programmable) fieldbus coupler or controller takes place using the implemented fieldbus specific application protocol, e. g. MODBUS TCP (UDP), EtherNet/IP, BACnet, KNXNET/IP, PROFINET, Powerlink, Sercos III or others.

4.1.2.1 Transmission Media

General ETHERNET transmission standards

For transmitting data the ETHERNET standard supports numerous technologies with various parameters (e.g., transmission speed, medium, segment length and type of transmission).

1Base5	Uses a 24 AWG UTP (twisted pair cable) for a 1Mbps baseband signal for distances up to 500 m (250 m per segment) in a physical star topology.
10Base2	Uses a 5 mm 50 Ohm coaxial cable for a 10Mbps baseband signal for distances of up to 185 m in a physical bus topology (often referred to as Thin ETHERNET or ThinNet).
10Base5	Uses a 10 mm 50 Ohm coaxial cable for a 10Mbps baseband signal for distances of up to 500 m in a physical bus topology (often referred to as Thick ETHERNET).
10Base-F	Uses a fiber-optic cable for a 10Mbps baseband signal for distances of up to 4 km in a physical star topology. (There are three sub-specifications: 10Base-FL for fiber-optic link, 10Base-FB for fiber-optic backbone and 10Base-FP for fiber-optic passive).
10Base-T	Uses a 24 AWG UTP or STP/UTP (twisted pair cable) for a 10Mbps baseband signal for distances up to 100 m in a physical star topology.
10Broad36	Uses a 75 Ohm coaxial cable for a 10Mbps baseband signal for distances of up to 1800 m (or 3600 m with double cables) in a physical bus topology.
100BaseTX	Specifies a 100 Mbps transmission with a twisted pair cable of Category 5 and RJ45-connectors. A maximum segment of 100 meters may be used.

Tab. 4-1: ETHERNET Transmission Standards

Beyond that there are still further transmission standards, for example: 100Base-T4 (Fast ETHERNET over twisted conductors), 100Base-FX (Fast ETHERNET over fiber-optic cables) or P802.11 (Wireless LAN) for a wireless transmission.

The media types are shown with their IEEE shorthand identifiers. The IEEE identifiers include three pieces of information.

The first item, for example, “10”, stands for the media.

The third part of the identifier provides a rough indication of segment type or length. For thick coaxial cable, the “5” indicates a 500 meter maximum length allowed for individual thick coaxial segments. For thin coaxial cable, the “2” is rounded up from the 185 meter maximum length for individual thin coaxial segments. The “T” and “F” stand for ‘twisted pair’ and ‘fiber optic’, and simply indicate the cable type.

10Base-T, 100BaseTX

Either the 10BaseT standard or 100BaseTX can be used for the WAGO ETHERNET fieldbus node.

The network architecture is very easy and inexpensive to assemble with S-UTP cable as transmission medium or with cables of STP type.

Both types of cable can be obtained from any computer dealer.

S-UTP cable (screened unshielded twisted pair) is single-shielded cable of Category 5 with overall shield surrounding all twisted unshielded conductor pairs and an impedance of 100 ohm.

STP cable (shielded twisted pair) is cable of Category 5 with stranded and individually shielded conductor pairs; no overall shield is provided.

Wiring of the fieldbus nodes

Maybe, a crossover cable is required for direct connection of a fieldbus node to the network card of the PC.

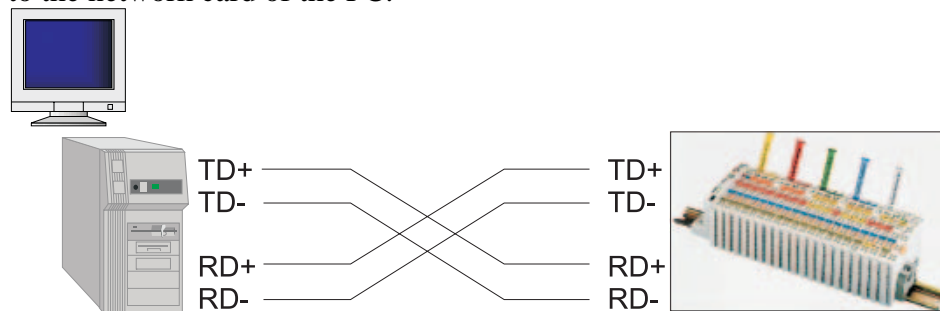

Fig. 4-2: Direct Connection of a Node with Crossover Cable

g012906d

If several fieldbus nodes are to be connected to a network card, the fieldbus nodes can be connected via an ETHERNET switch or hub with straight through/parallel cables.

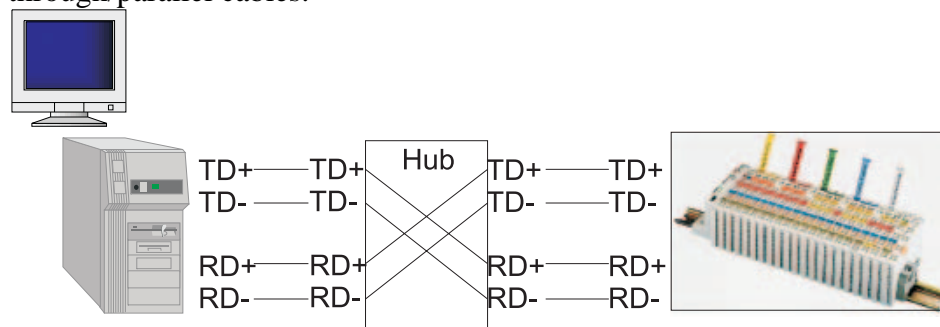

Fig. 4-3: Connection of a Node by means of a Hub with Parallel cables

g012908d

An ETHERNET switch is a device that allows all connected devices to transmit and receive data with each other. The switch can also be viewed as a “data traffic cop” where the hub “polices” the data coming in and going out of the individual ports, so the data will only be transmitted to the required node. WAGO recommends using a switch rather than a hub, this will allow for a more deterministic architecture.



Attention

The cable length between the node and the hub cannot be longer than 100 m (328 ft.) without adding signal conditioning systems (i.e., repeaters). Various possibilities are described in the ETHERNET standard for networks covering larger distances.

4.1.2.2 Network Topologies

In the case of 10Base-T, or 100BaseTX several stations (nodes) are connected using a star topology according to the 10Base-T ETHERNET Standard.

Therefore, this manual only deals with the star topology, and the tree topology for larger networks in more detail.

Star Topology

A star topology consists of a network in which all nodes are connected to a central point via individual cables.

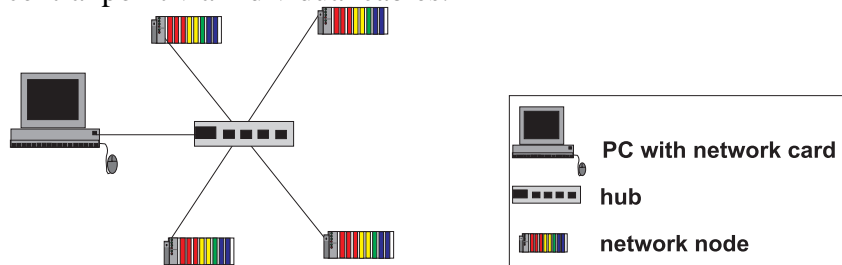

Fig. 4-4: Star Topology

G012903e

A star topology offers the advantage of allowing the extension of an existing network. Stations can be added or removed without network interruption. Moreover, in the event of a defective cable, only the network segment and the node connected to this segment is impaired. This considerably increases the fail-safe of the entire network.

Tree Topology

The tree topology combines characteristics of linear bus and star topologies. It consists of groups of star-configured workstations connected to a linear bus backbone cable. Tree topologies allow for the expansion of an existing network, and enables schools, etc. to configure a network to meet their needs.

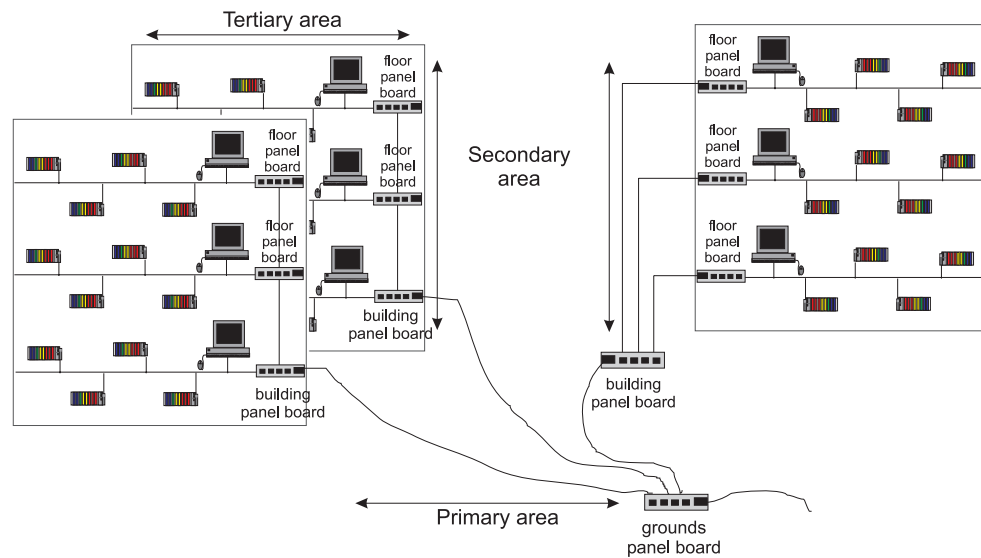

Fig. 4-5: Tree Topology

G012904e

5-4-3 Rule

A consideration in setting up a tree topology using ETHERNET protocol is the 5-4-3 rule. One aspect of the ETHERNET protocol requires that a signal sent out on the network cable must reach every part of the network within a specified length of time. Each concentrator or repeater that a signal goes through adds a small amount of time. This leads to the rule that between any two nodes on the network there can only be a maximum of 5 segments connected through 4 repeaters/concentrators. In addition, only 3 of the segments may be populated (trunk) segments if they are made of coaxial cable. A populated segment is one that has one or more nodes attached to it. In Figure 5-5, the 5-4-3 rule is adhered to. The furthest two nodes on the network have 4 segments and 3 repeaters/concentrators between them.

This rule does not apply to other network protocols or ETHERNET networks where all fiber optic cabling or a combination of a backbone with UTP cabling is used. If there is a combination of fiber optic backbone and UTP cabling, the rule is simply translated to 7-6-5 rule.

Cabling guidelines

"Structured Cabling" specifies general guidelines for network architecture of a LAN, establishing maximum cable lengths for the grounds area, building and floor cabling.

The "Structured Cabling" is standardized in EN 50173, ISO 11801 and TIA 568-A. It forms the basis for a future-orientated, application-independent and cost-effective network infrastructure.

The cabling standards define a domain covering a geographical area of 3 km and for an office area of up to 1 million square meters with 50 to 50,000 terminals. In addition, they describe recommendations for setting up of a cabling system.

Specifications may vary depending on the selected topology, the transmission media and coupler modules used in industrial environments, as well as the use of components from different manufacturers in a network. Therefore, the specifications given here are only intended as recommendations.

4.1.2.3 Coupler Modules

There are a number of hardware modules that allow for flexible arrangement for setting up an ETHERNET network. They also offer important functions, some of which are very similar.

The following table defines and compares these modules and is intended to simplify the correct selection and appropriate application of them.

Module	Characteristics/application	ISO/OSI layer
Repeater	Amplifier for signal regeneration, connection on a physical level.	1
Bridge	Segmentation of networks to increase the length.	2
Switch	Multiport bridge, meaning each port has a separate bridge function. Logically separates network segments, thereby reducing network traffic. Consistent use makes ETHERNET collision-free.	2 (3)
Hub	Used to create star topologies, supports various transmission media, does not prevent any network collisions.	2
Router	Links two or more data networks. Matches topology changes and incompatible packet sizes (e.g. used in industrial and office areas).	3
Gateway	Links two manufacturer-specific networks which use different software and hardware (i.e., ETHERNET and Interbus-Loop).	4-7

Tab. 4-2: Comparison of Coupler Modules for Networks

4.1.2.4 Important Terms

Data security

If an internal network (Intranet) is to be connected to the public network (e.g., the Internet) then data security is an extremely important aspect.

Undesired access can be prevented by a **Firewall**.

Firewalls can be implemented in software or network components. They are interconnected in a similar way to routers as a switching element between Intranets and the public network. Firewalls are able to limit or completely block all access to the other networks, depending on the access direction, the service used and the authenticity of the network user.

Real-time ability

Transmission above the fieldbus system level generally involves relatively large data quantities. The permissible delay times may also be relatively long (0.1...10 seconds).

However, real-time behavior within the fieldbus system level is required for ETHERNET in industry.

In ETHERNET it is possible to meet the real-time requirements by restricting the bus traffic (< 10 %), by using a master-slave principle, or also by implementing a switch instead of a hub.

MODBUS/TCP is a master/slave protocol in which the slaves only respond to commands from the master. When only one master is used, data traffic over the network can be controlled and collisions avoided.

Shared ETHERNET

Several nodes linked via a hub share a common medium. When a message is sent from a station, it is broadcast throughout the entire network and is sent to each connected node. Only the node with the correct target address processes the message. Collisions may occur and messages have to be repeatedly transmitted as a result of the large amount of data traffic. The delay time in a Shared ETHERNET cannot be easily calculated or predicted.

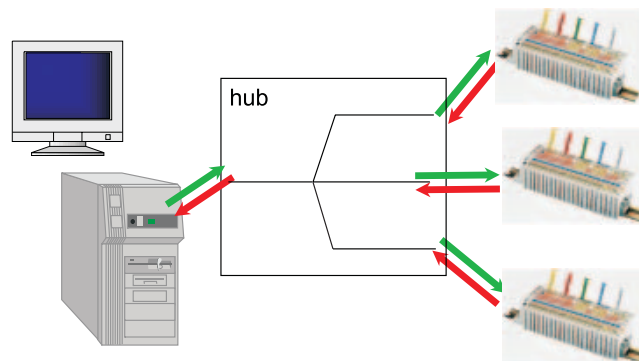

Fig. 4-6: Principle of Shared ETHERNET

G012910e

Deterministic ETHERNET

The TCP/IP software or the user program in each subscriber can limit transmittable messages to make it possible to determine real-time requirements. At the same time the maximum medium message rate (datagrams per second), the maximum medium duration of a message, and the minimum time interval between the messages (waiting time of the subscriber) is limited.

Therefore, the delay time of a message is predictable.

Switched ETHERNET

In the case of Switched Ethernet, several fieldbus nodes are connected by a switch. When data from a network segment reaches the switch, it saves the data and checks for the segment and the node to which this data is to be sent. The message is then only sent to the node with the correct target address. This reduces the data traffic over the network, extends the bandwidth and prevents collisions. The runtimes can be defined and calculated, making the Switched Ethernet deterministic.

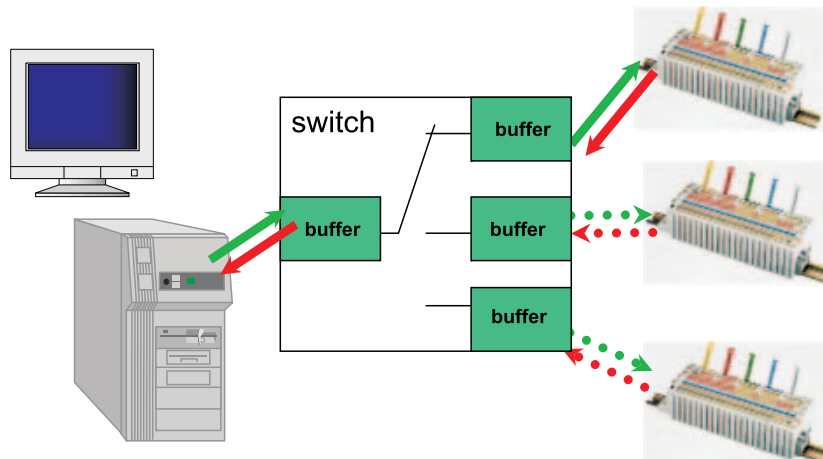

Fig. 4-7: Principle of Switched ETHERNET

G012909e

4.1.3 Network Communication

Fieldbus communication between master application and (programmable) fieldbus coupler or controller usually takes place using an implemented fieldbus specific application protocol, e. g. MODBUS TCP (UDP), EtherNet/IP, BACnet, KNXNET/IP, PROFINET, Powerlink, Sercos III or others.

The protocol layer model helps with an example (MODBUS and EtherNet/IP) to explain the classification and interrelationships between the communication and application protocols.

In this example, the fieldbus communication can take place using either the MODBUS protocol or EtherNet/IP.

4.1.3.1 Protocol layer model

(1) Ethernet:

The Ethernet hardware forms the basis for the physical exchange of data. The exchanged data signals and the bus access procedure CSMA/CD are defined in a standard.

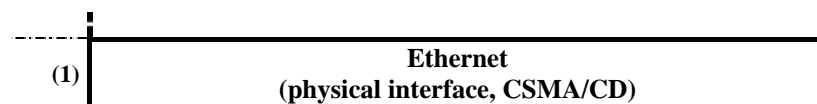

(2) IP:

For the communication the Internet Protocol (IP) is positioned above the Ethernet hardware. This bundles the data to be transmitted in packets along with sender and receiver address and passes these packets down to the Ethernet layer for physical transmission. At the receiver end, IP accepts the packets from the Ethernet layer and unpacks them.

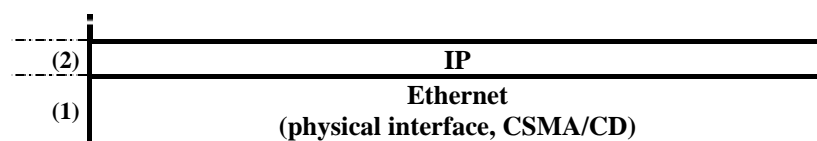

(3) TCP, UDP:

a) TCP: (Transmission Control Protocol)

The TCP protocol, which is positioned above the IP layer, monitors the transport of the data packets, sorts their sequence and sends repeat requests for missing packets. TCP is a connection-oriented transport protocol.

The TCP and IP protocol layers are also jointly described as the TCP/IP protocol stack or TCP/IP stack.

b) UDP: (User Datagram Protocol)

The UDP layer is also a transport protocol like TCP, and is arranged above the IP layer. In contrast to the TCP protocol, UDP is not connection oriented. That means there are no monitoring mechanisms for data exchange between sender and receiver.

The advantage of this protocol is in the efficiency of the transmitted data and the resultant increase in processing speed. Many programs use both protocols. Important status information is sent via the reliable TCP connection, while the main stream of data is sent via UDP.

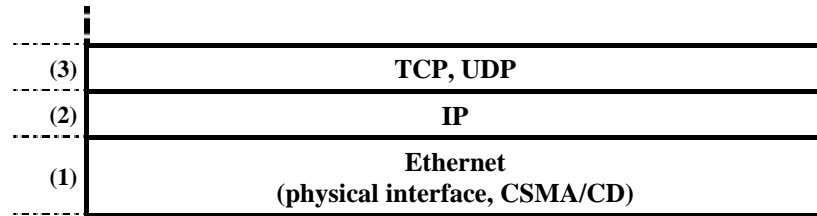

(4) Management, Diagnostic and Application Protocols:

Positioned above the TCP/IP stack or UDP/IP layer are correspondingly implemented management, diagnostic and application protocols that provide services that are appropriate for the application. For the management and diagnostic, these are, for example, SMTP (Simple Mail Transport Protocol) for e-mails, HTTP (Hypertext Transport Protocol) for www browsers and some others.

In this example, the protocols MODBUS/TCP (UDP) and EtherNet/IP are implemented for use in industrial data communication.

Here the MODBUS protocol is also positioned directly above TCP (UDP)/IP; EtherNet/IP, on the other hand, basically consists of the protocol layers Ethernet, TCP and IP with an encapsulation protocol positioned above it. This serves as interface to CIP (Control and Information Protocol).

DeviceNet uses CIP in the same way as EtherNet/IP. Applications with DeviceNet device profiles can therefore be very simply transferred to EtherNet/IP.

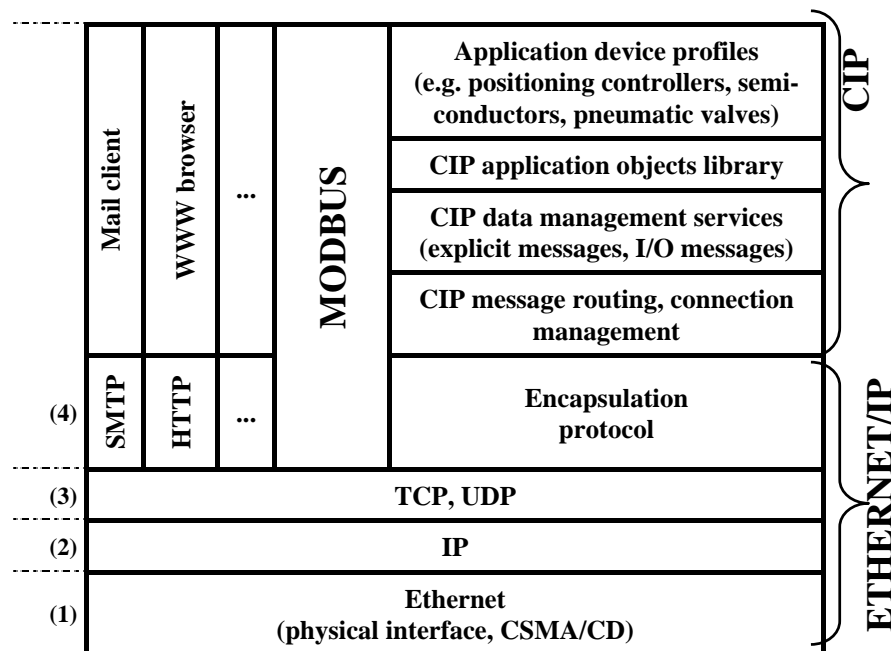

4.1.3.2 Communication Protocols

In addition to the ETHERNET standard, the following important communication protocols are implemented in the WAGO ETHERNET based (programmable) fieldbus couplers and controllers:

- IP Version 4 (Raw-IP and IP-Multicast)
- TCP
- UDP
- ARP

The following diagram is intended to explain the data structure of these protocols and how the data packets of the communication protocols Ethernet, TCP and IP with the adapted application protocol MODBUS nested in each other for transmission. A detailed description of the tasks and addressing schemes of these protocols is contained in the following.

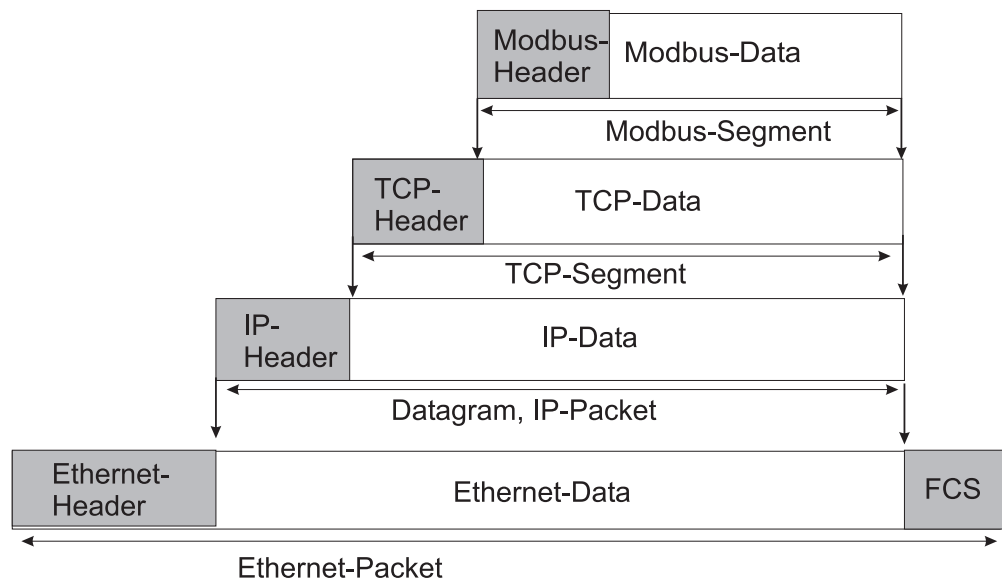

Fig. 4-8: Communication Protocols

G012907E

4.1.3.2.1 ETHERNET

ETHERNET address (MAC-ID)

Each WAGO ETHERNET (programmable) fieldbus coupler or controller is provided from the factory with a unique and internationally unambiguous physical ETHERNET address, also referred to as MAC-ID (Media Access Control Identity). This can be used by the network operating system for addressing on a hardware level.

The address has a fixed length of 6 Bytes (48 Bit) and contains the address type, the manufacturer's ID, and the serial number.

Examples for the MAC-ID of a WAGO ETHERNET fieldbus coupler (hexadecimal): 00_H.30_H.DE_H.00_H.00_H.01_H.

ETHERNET does not allow addressing of different networks.

If an ETHERNET network is to be connected to other networks, higher-ranking protocols have to be used.



Note

If you wish to connect one or more data networks, routers have to be used.

ETHERNET Packet

The datagrams exchanged on the transmission medium are called "ETHERNET packets" or just "packets". Transmission is connectionless; i.e. the sender does not receive any feedback from the receiver. The data used is packed in an address information frame. The following figure shows the structure of such a packet.

Preamble	ETHERNET-Header	ETHERNET_Data	Check sum
8 Byte	14 Byte	46-1500 Byte	4 Byte

Fig. 4-9: ETHERNET-Packet

The preamble serves as a synchronization between the transmitting station and the receiving station. The ETHERNET header contains the MAC addresses of the transmitter and the receiver, and a type field.

The type field is used to identify the following protocol by way of unambiguous coding (e.g., 0800_{hex} = Internet Protocol).

4.1.3.3 Channel access method

In the ETHERNET Standard, the fieldbus node accesses the bus using CSMA/CD (Carrier Sense Multiple Access/ Collision Detection).

- Carrier Sense: The transmitter senses the bus.
- Multiple Access: Several transmitters can access the bus.
- Collision Detection: A collision is detected.

Each station can send a message once it has established that the transmission medium is free. If collisions of data packets occur due to several stations transmitting simultaneously, CSMA/CD ensures that these are detected and the data transmission is repeated.

However, this does not make data transmission reliable enough for industrial requirements. To ensure that communication and data transmission via ETHERNET is reliable, various communication protocols are required.

4.1.3.3.1 IP-Protocol

The Internet protocol divides datagrams into segments and is responsible for their transmission from one network subscriber to another. The stations involved may be connected to the same network or to different physical networks which are linked together by routers.

Routers are able to select various paths (network transmission paths) through connected networks, and bypass congestion and individual network failures. However, as individual paths may be selected which are shorter than other paths, datagrams may overtake each other, causing the sequence of the data packets to be incorrect.

Therefore, it is necessary to use a higher-level protocol, for example, TCP to guarantee correct transmission.

IP addresses

To allow communication over the network each fieldbus node requires a 32 bit Internet address (IP address).



Attention

Internet addresses have to be unique throughout the entire interconnected networks.

As shown below there are various address classes with net identification (net ID) and subscriber identification (subscriber ID) of varying lengths. The net ID defines the network in which the subscriber is located. The subscriber ID identifies a particular subscriber within this network.

Networks are divided into various network classes for addressing purposes:

- **Class A:** (Net-ID: Byte1, Host-ID: Byte2 - Byte4)

e.g.: 101 . 16 . 232 . 22

01100101	00010000	11101000	00010110
0	Net-ID	Host-ID	

↑ The highest bit in Class A networks is always '0'.
 Meaning the highest byte can be in a range of '0 0000000' to '0 1111111'.

Therefore, the address range of a Class A network in the first byte is always between 0 and 127.

- **Class B: (Net-ID: Byte1 - Byte2, Host-ID: Byte3 - Byte4)**

e.g.: 181 . 16 . 232 . 22

10110101	00010000	11101000	00010110
10	Net-ID	Host-ID	

↑ The highest bits in Class B networks are always '10'.
Meaning the highest byte can be in a range of
'10 000000' to '10 111111'.

Therefore, the address range of Class B networks in the first byte is always between 128 and 191.

- **Class C: (Net-ID: Byte1 - Byte3, Host-ID: Byte4)**

e.g.: 201 . 16 . 232 . 22

11000101	00010000	11101000	00010110
110	Net-ID	Host-ID	

↑ The highest bits in Class C networks are always '110'.
Meaning the highest byte can be in a range of
'110 00000' to '110 11111'.

Therefore, the address range of Class C networks in the first byte is always between 192 and 223.

Additional network classes (D, E) are only used for special tasks.

Key data

	Address range of the subnetwork	Possible number of	
		networks	Subscribers per network
Class A	1.XXX.XXX.XXX - 126.XXX.XXX.XXX	127 (2^7)	Ca. 16 Million (2^{24})
Class B	128.000.XXX.XXX - 191.255.XXX.XXX	Ca. 16 thousand (2^{14})	Ca 65 thousand (2^{16})
Class C	192.000.000.XXX - 223.255.255.XXX	Ca. 2 million (2^{21})	254 (2^8)

Each WAGO ETHERNET (programmable) fieldbus coupler or controller can be easily assigned an IP address via the implemented BootP protocol. For small internal networks we recommend selecting a network address from Class C.



Attention

Never set all bits to equal 0 or 1 in one byte (byte = 0 or 255). These are reserved for special functions and may not be allocated. Therefore, the address 10.0.10.10 may not be used due to the 0 in the second byte.

If a network is to be directly connected to the Internet, only registered, internationally unique IP addresses allocated by a central registration service may be used. These are available from InterNIC (International Network Information Center).



Attention

Direct connection to the Internet should only be performed by an authorized network administrator and is therefore not described in this manual.

Subnets

To allow routing within large networks a convention was introduced in the specification *RFC 950*. Part of the Internet address, the subscriber ID is divided up again into a subnetwork number and the station number of the node. With the aid of the network number it is possible to branch into internal subnetworks within the partial network, but the entire network is physically connected together. The size and position of the subnetwork ID are not defined; however, the size is dependent upon the number of subnets to be addressed and the number of subscribers per subnet.

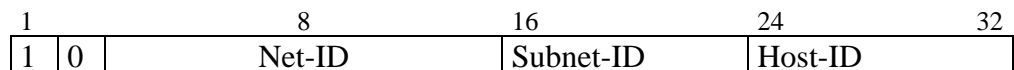

Fig. 4-10: Class B address with Field for Subnet ID

Subnet mask

A subnet mask was introduced to encode the subnets in the Internet. This involves a bit mask, which is used to mask out or select specific bits of the IP address. The mask defines the subscriber ID bits used for subnet coding, which denote the ID of the subscriber. The entire IP address range theoretically lies between 0.0.0.0 and 255.255.255.255. Each 0 and 255 from the IP address range are reserved for the subnet mask.

The standard masks depending upon the respective network class are as follows:

- **Class A Subnet mask:**

255	.0	.0	.0
-----	----	----	----

- **Class B Subnet mask:**

255	.255	.0	.0
-----	------	----	----

- **Class C Subnet mask:**

255	.255	.255	.0
-----	------	------	----

Depending on the subnet division the subnet masks may, however, contain other values beyond 0 and 255, such as 255.255.255.128 or 255.255.255.248. Your network administrator allocates the subnet mask number to you.

Together with the IP address, this number determines which network your PC and your node belongs to.

The recipient node, which is located on a subnet initially, calculates the correct network number from its own IP address and the subnet mask. Only then does it check the node number and delivers the entire packet frame, if it corresponds.

Example of an IP address from a class B network:

IP address:	172.16.233.200	10101100 00010000 11101001 11001000
Subnet mask:	255.255.255.128	11111111 11111111 11111111 10000000
Net-ID:	172.16.00	10101100 00010000 00000000 00000000
Subnet-ID:	0.0.233.128	00000000 00000000 11101001 10000000
Host-ID:	0.0.0.72	00000000 00000000 00000000 01001000



Attention

Specify the network mask defined by the administrator in the same way as the IP address when installing the network protocol.

Gateway

The subnets of the Internet are normally connected via gateways. The function of these gateways is to forward packets to other networks or subnets.

This means that in addition to the IP address and network mask for each network card, it is necessary to specify the correct IP address of the standard gateway for a PC or fieldbus node connected to the Internet. You should also be able to obtain this IP address from your network administrator.

The IP function is limited to the local subnet if this address is not specified.

IP Packet

In addition to the data units to be transported, the IP data packets contain a range of address information and additional information in the packet header.

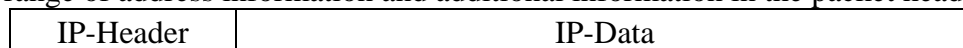

Fig. 4-11: IP Packet

The most important information in the IP header is the IP address of the transmitter and the receiver and the transport protocol used.

4.1.3.3.1.1 RAW IP

Raw IP manages without protocols such as PPP (point-to-point protocol). With RAW IP, the TCP/IP packets are directly exchanged without handshaking, thus enabling the connection to be established more quickly.

However, the connection must beforehand have been configured with a fixed IP address. The advantages of RAW IP are high data transfer rate and good stability.

4.1.3.3.1.2 IP Multicast

Multicast refers to a method of transmission from a point to a group, which is a point-to-multipoint transfer or multipoint connection. The advantage of multicast is that messages are simultaneously transferred to several users or closed user groups via one address.

IP multicasting at Internet level is realised with the help of the *Internet Group Message Protocol* IGMP; neighbouring routers use this protocol to inform each other on membership to the group.

For distribution of multicast packets in the sub-network, IP assumes that the datalink layer supports multicasting. In the case of Ethernet, you can provide a packet with a multicast address in order to send the packet to several recipients with a single send operation. Here, the common medium enables packets to be sent *simultaneously* to several recipients. The stations do not have to inform each other on who belongs to a specific multicast address – every station physically receives every packet. The resolution of IP address to Ethernet address is solved by the use of algorithms, IP multicast addresses are embedded in Ethernet multicast addresses.

4.1.3.3.2 TCP Protocol

As the layer above the Internet protocol, TCP (Transmission Control Protocol) guarantees the secure transport of data through the network.

TCP enables two subscribers to establish a connection for the duration of the data transmission. Communication takes place in full-duplex mode (i.e., transmission between two subscribers in both directions simultaneously).

TCP provides the transmitted message with a 16-bit checksum and each data packet with a sequence number.

The receiver checks that the packet has been correctly received on the basis of the checksum and then sets off the sequence number. The result is known as the acknowledgement number and is returned with the next self-sent packet as an acknowledgement.

This ensures that the lost TCP packets are detected and resent, if necessary, in the correct sequence.

TCP port numbers

TCP can, in addition to the IP address (network and subscriber address), respond to a specific application (service) on the addressed subscriber. For this the applications located on a subscriber, such as a web server, FTP server and others are addressed via different port numbers. Well-known applications are assigned fixed ports to which each application can refer when a connection is built up.

Examples:

Telnet	Port number: 23
HTTP	Port number: 80

A complete list of "standardized services" is contained in the *RFC 1700* (1994) specifications.

TCP segment

The packet header of a TCP data packet is comprised of at least 20 bytes and contains, among others, the application port number of the transmitter and the receiver, the sequence number and the acknowledgement number.

The resulting TCP packet is used in the data unit area of an IP packet to create a TCP/IP packet.

4.1.3.3.3 UDP

The UDP protocol, like the TCP protocol, is responsible for the transport of data. Unlike the TCP protocol, UDP is not connection-orientated; meaning that there are no control mechanisms for the data exchange between transmitter and receiver. The advantage of this protocol is the efficiency of the transmitted data and the resulting higher processing speed.

4.1.3.3.4 ARP

ARP (Address Resolution Protocol).

This protocol combines the IP address with the physical MAC address of the respective Ethernet card. It is always used when data transfer to an IP address takes place in the same logical network in which the sender is located.

4.1.3.4 Administration and Diagnosis Protocols

In addition to the communication protocols described above, various fieldbus specific application protocols and a view protocols for system admimnistration and diagnosis can be implemented.

- BootP
- HTTP
- DHCP
- DNS
- SNTP
- FTP
- SMTP.

More information



You can find a list of the exact available implemented protocols in the chapter "Technical Data" to the fieldbus coupler and/or controller.

4.1.3.4.1 BootP (Bootstrap Protocol)

The BootP protocol defines a request/response mechanism with which the MAC-ID of a fieldbus node can be assigned a fix IP address.

For this a network node is enabled to send requests into the network and call up the required network information, such as the IP address of a BootP server. The BootP server waits for BootP requests and generates the response from a configuration database.

The dynamic configuration of the IP address via a BootP server offers the user a flexible and simple design of his network. The WAGO BootP server allows any IP address to be easily assigned for the WAGO (programmable) fieldbus coupler or controller. You can download a free copy of the WAGO BootP server over the Internet at: <http://www.wago.com>.

More information



The procedure for address allocation with the WAGO BootP Server is described in detail in the Chapter "Starting up a Fieldbus Node".

The BOOTP Client allows for dynamic configuring of the network parameters:

Parameter	Meaning
IP address of the client	Network address of the (programmable) fieldbus coupler or controller
IP address of the router	If communication is to take place outside of the local network, the IP address of the routers (gateway) is indicated in this parameter.
Subnet mask	The Subnet mask makes the (programmable) fieldbus coupler or controller able to differentiate, which parts of

	the IP address determine the network and which the network station.
IP addresses of the DNS servers	Here the IP addresses can be entered by maximally 2 DNS servers.
Host name	Name of the host

When using the bootstrap protocol for configuring the node, the network parameters (IP address, etc...) are stored in the EEPROM.



Note

The network configuration is only stored in the EEPROM when the BootP protocol is used, although not if configuration is done via DHCP.

The BootP protocol is activated in the (programmable) fieldbus coupler or controller by default.

When the BootP protocol is activated, the (programmable) fieldbus coupler or controller expects a BootP server to be permanently present.

If, however, there is no BootP server available after a power-on reset, the network remains inactive.

To operate the (programmable) fieldbus coupler or controller with the IP configuration stored in the EEPROM, you must first deactivate the BootP protocol.

This is done via the web-based management system on the appropriate HTML page saved in the (programmable) fieldbus coupler or controller, which is accessed via the “Port” link.

If the BootP protocol is deactivated, the (programmable) fieldbus coupler or controller uses the parameters stored in the EEPROM at the next boot cycle.

If there is an error in the stored parameters, a blink code is output via the IO LED and configuration via BootP is automatically switched on.

4.1.3.4.2 HTTP (HyperText Transfer Protocol)

HTTP is a protocol used by WWW (World Wide Web) servers for the forwarding of hypermedia, texts, images, audiodata, etc.

Today, HTTP forms the basis of the Internet and is also based on requests and responses in the same way as the BootP protocol.

The HTTP server implemented in the (programmable) fieldbus coupler or controller is used for viewing the HTML pages saved in the coupler/controller. The HTML pages provide information about the coupler/controller (state, configuration), the network and the process image.

On some HTML pages, (programmable) fieldbus coupler or controller settings can also be defined and altered via the web-based management system (e.g. whether IP configuration of the coupler/controller is to be performed via the DHCP protocol, the BootP protocol or from the data stored in the EEPROM). The HTTP server uses port **number 80**.

4.1.3.4.3 DHCP (Dynamic Host Configuration Protocol)

The coupler's/controller's built-in HTML pages provide an option for IP configuration from a DHCP server, a BootP server, or the data stored in its EEPROM by default.



Note

The network configuration via DHCP is not stored in the EEPROM, this only occurs when using the BootP protocol.

The DHCP client allows dynamic network configuration of the coupler/controller by setting the following parameters:

Parameter	Meaning
IP address of the client	Network address of the coupler/controller
IP address of the router	If communication is to take place outside of the local network, the IP address of the routers (gateway) is indicated in this parameter.
Subnet mask	The Subnet mask makes the coupler/controller able to differentiate, which parts of the IP address determine the network and which the network station.
IP addresses of the DNS servers	Here the IP addresses can be entered by maximally 2 DNS servers.
Lease time	Here the maximum duration can be defined, how long the coupler/controller keeps the assigned IP address. The maximum lease time is 24.8 days. This results from the internal resolution of timer.
Renewing time	The Renewing time indicates, starting from when the coupler/controller must worry about the renewal of the leasing time.
Rebinding time	The Rebinding time indicates, after which time the coupler/controller must have gotten its new address.

In the case of configuration of network parameters via the DHCP protocol, the coupler/controller automatically sends a request to a DHCP server after initialisation. If there is no response, the request is sent again after 4 seconds, a further one after 8 seconds and again after 16 seconds. If all requests remain unanswered, a blink code is output via the "IO" LED. Transfer of the parameters from the EEPROM is not possible.

Where a lease time is used, the values for the renewing and rebinding time must also be specified. After the renewing time expires, the coupler/controller attempts to automatically renew the lease time for its IP address. If this continually fails up to the rebinding time, the coupler/controller attempts to obtain a new IP address. The time for the renewing should be about one half of the lease time. The rebinding time should be about $\frac{7}{8}$ of the lease time.

4.1.3.4.4 DNS (Domain Name Systems)

The DNS client enables conversion of logical Internet names such as www.wago.com into the appropriate decimal IP address represented with separator stops, via a DNS server. Reverse conversion is also possible. The addresses of the DNS server are configured via DHCP or web-based management. Up to 2 DNS servers can be specified. The host identification can be achieved with two functions, an internal host table is not supported.

4.1.3.4.5 SNTP-Client (Simple Network Time Protocol)

The SNTP client is used for synchronization of the time of day between a time server (NTP and SNTP server Version 3 and 4 are supported) and the clock module integrated in the (programmable) fieldbus coupler or controller. The protocol is executed via a UDP port. Only unicast addressing is supported.

Configuration of the SNTP client

The configuration of the SNTP client is performed via the web-based management system under the “Clock” link. The following parameters must be set:

Parameter	Meaning
Address of the Time server	The address assignment can be made either over a IP address or a host name.
Time zone	The time zone relative to GMT (Greenwich Mean time). A range of -12 to +12 hours is acceptable.
Update Time	The update time indicates the interval in seconds, in which the synchronization with the time server is to take place.
Enable Time Client	It indicates whether the SNTP Client is to be activated or deactivated.

4.1.3.4.6 FTP-Server (File Transfer Protocol)

The file transfer protocol (FTP) enables files to be exchanged between different network stations regardless of operating system.

In the case of the ETHERNET coupler/controller, FTP is used to store and read the HTML pages created by the user, the IEC61131 program and the IEC61131 source code in the (programmable) fieldbus coupler or controller.

A total memory of 1.5 MB is available for the file system. The file system is mapped to RAM disk. To permanently store the data of the RAM disk, the information is additionally copied into the flash memory. The data is stored in the flash after the file has been closed. Due to the storage process, access times during write cycles are long.



Note

Up to 1 million write cycles are possible for writing to the flash memory for the file system.

The following table shows the supported FTP commands for accesses to the file system:

Command	Function
USER	Identification of the user
PASS	User password
ACCT	Account for access to certain files
REIN	Server reset
QUIT	Terminates the connection
PORT	Addressing of the data link
PASV	Changes server in the listen mode
TYPE	Determines the kind of the representation for the transferred file
STRU	Determines the structure for the transferred file
MODE	Determines the kind of file transmission
RETR	Reads file from server
STOR	Saves file on server
APPE	Saves file on server (Append mode)
ALLO	Reservation of the necessary storage location for the file
RNFR	Renames file from (with RNTO)
RNTO	Renames file in (with RNFR)
ABOR	Stops current function
DELE	Deletes file
CWD	Changes directory
LIST	Gives the directory list
NLST	Gives the directory list
RMD	Deletes directory
PWD	Gives the actually path
MKD	Puts on a dirctory

The TFTP (Trival File Transfer Protocol) is not supported by some of the couplers/controllers.



More information

You can find a list of the exact available implemented protocols in the chapter "Technical Data" to the fieldbus coupler and/or controller.

4.1.3.4.7 SMTP (Simple Mail Transfer Protocol)

The Simple Mail Transfer Protocol (SMTP) enables sending of ASCII text messages to mail boxes on TCP/IP hosts in a network. It is therefore used for sending and receiving e-mails.

The e-mail to be sent is created with a suitable editor and placed in a mail outbasket.

A send SMTP process polls the out-basket at regular intervals and therefore finds mail waiting to be sent. It then establishes a TCP/IP connection with the target host, to which the message is transmitted. The receive SMTP process on the target host accepts the TCP connection. The message is then transmitted and finally placed in an in-basket on the target system. SMTP expects the target system to be online, otherwise no TCP connection can be established. Since many desktop computers are switched off at the end of the day, it is impractical to send SMTP mail there. For that reason, in many networks special SMTP hosts are installed in many networks, which are permanently switched on to enable distribution of received mail to the desktop computers.

4.1.3.5 Application Protocols

If fieldbus specific application protocols are implemented, then the appropriate fieldbus specific communication is possible with the respective coupler/controller. Thus the user is able to have a simple access from the respective fieldbus on the fieldbus node. There are based on ETHERNET couplers/controllers available developed by WAGO, with the following possible application protocols:

- MODBUS TCP (UDP)
- EtherNet/IP
- BACnet
- KNXnet/IP
- PROFINET
- Powerlink
- Sercos III



More information

You can find a list of the exact available implemented protocols in the chapter "Technical Data" to the fieldbus coupler and/or controller.

If fieldbus specific application protocols are implemented, then these protocols are individual described in the following chapters.

4.2 MODBUS Functions

4.2.1 General

MODBUS is a manufacturer-independent, open fieldbus standard for diverse applications in manufacturing and process automation.

The MODBUS protocol is implemented for the transmission of the process image, the fieldbus variables, different settings and information on the coupler according to the current Internet Draft.

The data transmission in the fieldside takes place via TCP and via UDP.

The MODBUS/TCP protocol is a variation of the MODBUS protocol, which was optimized for communication via TCP/IP connections.

This protocol was designed for data exchange in the field level (i.e. for the exchange of I/O data in the process image).

All data packets are sent via a TCP connection with the **port number 502**.

MODBUS/TCP segment

The general MODBUS/TCP header is as follows:

Byte:	0	1	2	3	4	5	6	7	8 - n
	Identifier (entered by receiver)		Protocol- identifier (is always 0)		Length field (High byte, Low byte)		Unit identifier (Slave address)	MODBUS function code	Data

Fig. 4-12: MODBUS/TCP Header



More information

The structure of a datagram is specific for the individual function. Refer to the descriptions of the MODBUS Function Codes.

For the MODBUS protocol 5 connections are made available over TCP. Thus it allows digital and analog output data to be directly read out at a fieldbus node and special functions to be executed by way of simple MODBUS function codes from 5 stations simultaneously.

For this purpose a set of MODBUS functions from the *OPEN MODBUS /TCP SPECIFICATION* is realized.



More information

More information on the *OPEN MODBUS /TCP SPECIFICATION* you can find in the Internet: www.modbus.org.

Therefore the MODBUS protocol based essentially on the following basic data types:

Datatype	Length	Description
Discrete Inputs	1 Bit	Digital Inputs
Coils	1 Bit	Digital Outputs
Input Register	16 Bit	Analog-Input data
Holding Register	16 Bit	Analog-Output data

For each basic data type one or more „FunctionCodes“ are defined.

These functions allow digital or analog input and output data, and internal variables to be set or directly read out of the fieldbus node.

Function code	hexadec.	Function	Access method and description	Access to resources
FC1:	0x01	Read Coils	Reading of several single input bits	R: Process image
FC2:	0x02	Read Input Discretes	Reading of several input bits	R: Process image
FC3:	0x03	Read Multiple Registers	Reading of several input registers	R: Process image, internal variables
FC4:	0x04	Read Input Registers	Reading of several input registers	R: Process image, internal variables
FC5:	0x05	Write Coil	Writing of an individual output bit	W: Process image
FC6:	0x06	Write Single Register	Writing of an individual output register	W: Process image, internal variables
FC7:	0x07	Read Exception Status	Reading of the first input bits	R: Process image
FC 11:	0x0B	Get Comm Event Counters	Communication event counter	R: None
FC 15:	0x0F	Force Multiple Coils	Writing of several output bits	W: Process image
FC 16:	0x0010	Write Multiple Registers	Writing of several output registers	W: Process image, internal variables
FC 23:	0x0017	Read/Write Registers	Reading and writing of several output registers	R/W: Process image

Tab. 4-3: List of the MODBUS Functions in the Fieldbus Coupler

To execute a desired function, specify the respective function code and the address of the selected input or output data.



Attention

The examples listed use the hexadecimal system (i.e.: 0x000) as their numerical format. Addressing begins with 0.

The format and beginning of the addressing may vary according to the software and the control system. All addresses then need to be converted accordingly.

4.2.2 Use of the MODBUS Functions

The example below uses a graphical view of a fieldbus node to show which MODBUS functions can be used to access data of the process image.

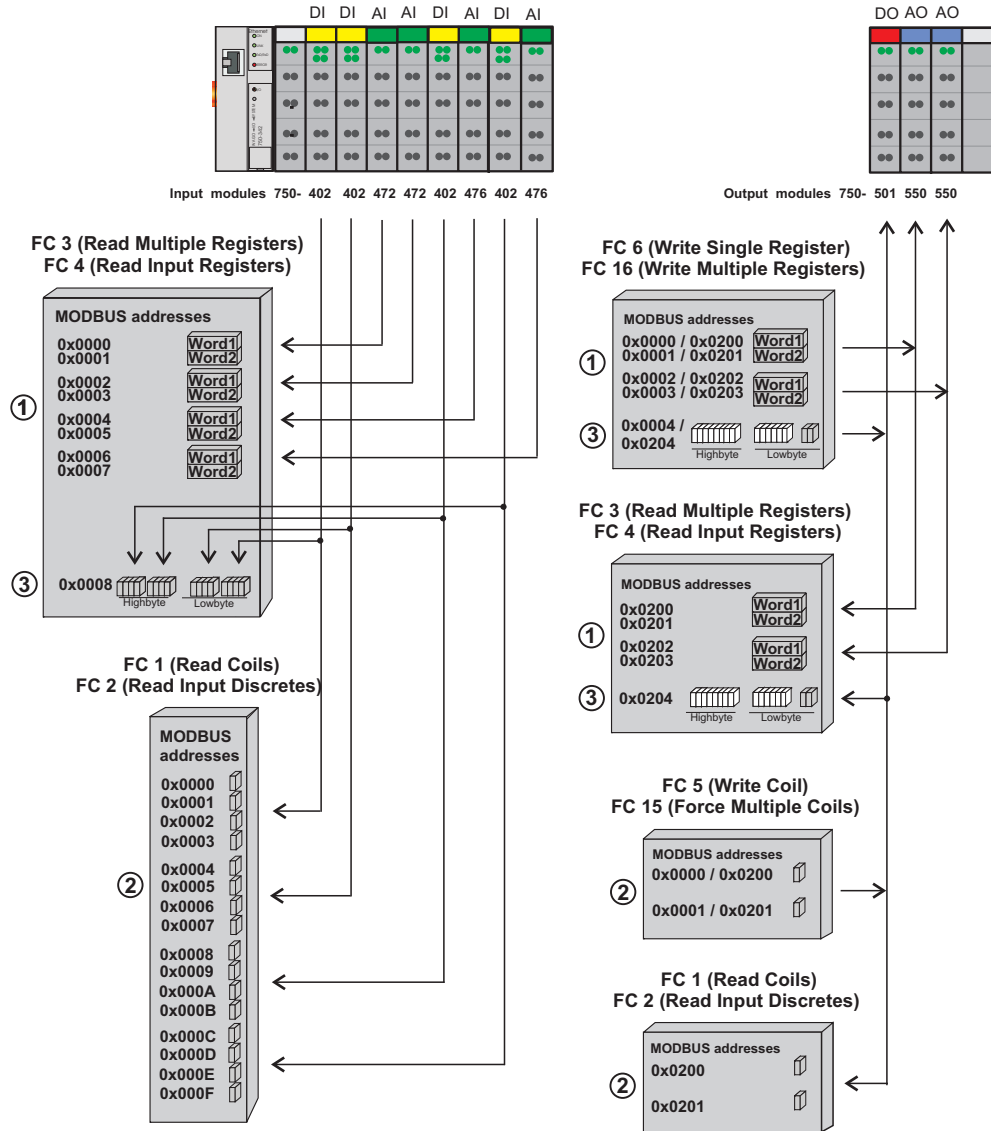

Fig. 4-13: Use of the MODBUS Functions

G012918e



Attention

It is recommended that analog data be accessed with register functions (1) and digital data with coil functions (2).

4.2.3 Description of the MODBUS Functions

All MODBUS functions are executed as follows:

A MODBUS TCP master (e.g., a PC) makes a request to the WAGO fieldbus node using a specific function code based on the desired operation. The WAGO fieldbus node receives the datagram and then responds to the master with the proper data, which is based on the master's request.

If the WAGO fieldbus node receives an incorrect request, it sends an error datagram (Exception) to the master.

The exception code contained in the exception has the following meaning:

Exception Code	Meaning
0x01	Illegal Function
0x02	Illegal Data Address
0x03	Illegal Data Value
0x04	Slave Device Failure
0x05	Acknowledge
0x06	Server Busy
0x08	Memory Parity Error
0x0A	Gateway Path Unavailable
0x0B	Gateway Target Device Failed To Respond

The following chapters describe the datagram architecture of request, response and exception with examples for each function code.



Note

In the case of the read functions (FC1 – FC4) the outputs can be additionally written and read back by adding an offset of 200_{hex} (0x0200) to the MODBUS addresses in the range of [0_{hex} - FF_{hex}] and an offset of 1000_{hex} (0x01000) to the MODBUS addresses in the range of [6000_{hex} - 62FC_{hex}].

4.2.3.1 Function Code FC1 (Read Coils)

This function reads the status of the input and output bits (coils) in a slave device.

Request

The request specifies the reference number (starting address) and the bit count to read.

Example: Read output bits 0 to 7.

Byte	Field name	Example
Byte 0, 1	Transaction identifier	0x0000
Byte 2, 3	protocol identifier	0x0000
Byte 4, 5	length field	0x0006
Byte 6	unit identifier	0x01 not used
Byte 7	MODBUS function code	0x01
Byte 8, 9	reference number	0x0000
Byte 10, 11	Bit count	0x0008

Response

The current values of the response bits are packed in the data field. A binary 1 corresponds to the ON status and a 0 to the OFF status. The lowest value bit of the first data byte contains the first bit of the request. The others follow in ascending order. If the number of inputs is not a multiple of 8, the remaining bits of the last data byte are filled with zeroes (truncated).

Byte	Field name	Example
.....		
Byte 7	MODBUS function code	0x01
Byte 8	Byte count	0x01
Byte 9	Bit values	0x12

The status of the inputs 7 to 0 is shown as byte value 0x12 or binary 0001 0010. Input 7 is the bit having the highest significance of this byte and input 0 the lowest value.

The assignment is thus made from 7 to 0 with OFF-OFF-OFF-ON-OFF-OFF-ON-OFF.

```
Bit:   0 0 0 1 0 0 1 0
Coil:  7 6 5 4 3 2 1 0
```

Exception

Byte	Field name	Example
.....		
Byte 7	MODBUS function code	0x81
Byte 8	Exception code	0x01 or 0x02

4.2.3.2 Function Code FC2 (Read Input Discretes)

This function reads the input bits from a slave device.

Request

The request specifies the reference number (starting address) and the bit count to be read.

Example: Read input bits 0 to 7:

Byte	Field name	Example
Byte 0, 1	Transaction identifier	0x0000
Byte 2, 3	protocol identifier	0x0000
Byte 4, 5	Length field	0x0006
Byte 6	unit identifier	0x01 not used
Byte 7	MODBUS function code	0x02
Byte 8, 9	reference number	0x0000
Byte 10, 11	Bit count	0x0008

Response

The current value of the requested bits are packed into the data field. A binary 1 corresponds to the ON status and a 0 the OFF status. The lowest value bit of the first data byte contains the first bit of the inquiry. The others follow in an ascending order. If the number of inputs is not a multiple of 8, the remaining bits of the last data byte are filled with zeroes (truncated).

Byte	Field name	Example
.....		
Byte 7	MODBUS function code	0x02
Byte 8	Byte count	0x01
Byte 9	Bit values	0x12

The status of the inputs 7 to 0 is shown as a byte value 0x12 or binary 0001 0010.

Input 7 is the bit having the highest significance of this byte and input 0 the lowest value.

The assignment is thus made from 7 to 0 with OFF-OFF-OFF-ON-OFF-OFF-ON-OFF.

Bit: 0 0 0 1 0 0 1 0
 Coil: 7 6 5 4 3 2 1 0

Exception

Byte	Field name	Example
.....		
Byte 7	MODBUS function code	0x82
Byte 8	Exception code	0x01 or 0x02

4.2.3.3 Function Code FC3 (Read multiple registers)

This function reads the contents of holding registers from a slave device in word format.

Request

The request specifies the reference number (start register) and the word count (register quantity) of the registers to be read. The reference number of the request is zero based, therefore, the first register starts at address 0.

Example: Read registers 0 and 1:

Byte	Field name	Example
Byte 0, 1	Transaction identifier	0x0000
Byte 2, 3	protocol identifier	0x0000
Byte 4, 5	length field	0x0006
Byte 6	unit identifier	0x01 not used
Byte 7	MODBUS function code	0x03
Byte 8, 9	reference number	0x0000
Byte 10, 11	Word count	0x0002

Response

The reply register data is packed as 2 bytes per register. The first byte contains the higher value bits, the second the lower values.

Byte	Field name	Example
.....		
Byte 7	MODBUS function code	0x03
Byte 8	Byte count	0x04
Byte 9, 10	Value Register 0	0x1234
Byte 11, 12	Value Register 1	0x2345

The contents of register 0 are displayed by the value 0x1234 and the contents of register 1 is 0x2345.

Exception

Byte	Field name	Example
.....		
Byte 7	MODBUS function code	0x83
Byte 8	Exception code	0x01 or 0x02

4.2.3.4 Function code FC4 (Read input registers)

This function reads contents of input registers from the slave device in word format.

Request

The request specifies a reference number (start register) and the word count (register quantity) of the registers to be read. The reference number of the request is zero based, therefore, the first register starts at address 0.

Example: Read registers 0 and 1:

Byte	Field name	Example
Byte 0, 1	Transaction identifier	0x0000
Byte 2, 3	protocol identifier	0x0000
Byte 4, 5	length field	0x0006
Byte 6	unit identifier	0x01 not used
Byte 7	MODBUS function code	0x04
Byte 8, 9	reference number	0x0000
Byte 10, 11	Word count	0x0002

Response

The register data of the response is packed as 2 bytes per register. The first byte has the higher value bits, the second the lower values.

Byte	Field name	Example
.....		
Byte 7	MODBUS function code	0x04
Byte 8	Byte count	0x04
Byte 9, 10	Value Register 0	0x1234
Byte 11, 12	Value Register 1	0x2345

The contents of register 0 are shown by the value 0x1234 and the contents of register 1 is 0x2345.

Exception

Byte	Field name	Example
.....		
Byte 7	MODBUS function code	0x84
Byte 8	Exception code	0x01 or 0x02

4.2.3.5 Function Code FC5 (Write Coil)

This function writes a single output bit to the slave device.

Request

The request specifies the reference number (output address) of output bit to be written. The reference number of the request is zero based; therefore, the first coil starts at address 0.

Example: Turn ON the second output bit (address 1):

Byte	Field name	Example
Byte 0, 1	Transaction identifier	0x0000
Byte 2, 3	protocol identifier	0x0000
Byte 4, 5	length field	0x0006
Byte 6	unit identifier	0x01 not used
Byte 7	MODBUS function code	0x05
Byte 8, 9	reference number	0x0001
Byte 10	ON/OFF	0xFF
Byte 11		0x00

Response

Byte	Field name	Example
.....		
Byte 7	MODBUS function code	0x05
Byte 8, 9	Reference number	0x0001
Byte 10	Value	0xFF
Byte 11		0x00

Exception

Byte	Field name	Example
.....		
Byte 7	MODBUS function code	0x85
Byte 8	Exception code	0x01, 0x02 or 0x03

4.2.3.6 Function Code FC6 (Write single register)

This function writes the value of one single output register to a slave device in word format.

Request

The request specifies the reference number (register address) of the first output word to be written. The value to be written is specified in the “Register Value” field. The reference number of the request is zero based; therefore, the first register starts at address 0.

Example: Write a value of 0x1234 to the second output register.

Byte	Field name	Example
Byte 0, 1	Transaction identifier	0x0000
Byte 2, 3	protocol identifier	0x0000
Byte 4, 5	length field	0x0006
Byte 6	Unit identifier	0x01 not used
Byte 7	MODBUS function code	0x06
Byte 8, 9	reference number	0x0001
Byte 10, 11	Register Value	0x1234

Response

The reply is an echo of the inquiry.

Byte	Field name	Example
.....		
Byte 7	MODBUS function code	0x06
Byte 8, 9	Reference number	0x0001
Byte 10, 11	Register Value	0x1234

Exception

Byte	Field name	Example
.....		
Byte 7	MODBUS function code	0x85
Byte 8	Exception code	0x01 or 0x02

4.2.3.7 Function code FC7 (Read Exception Status)

This function reads the first 8 bits of the process output image.

Request

Byte	Field name	Example
Byte 0, 1	Transaction identifier	0x0000
Byte 2, 3	protocol identifier	0x0000
Byte 4, 5	length field	0x0002
Byte 6	unit identifier	0x01 not used
Byte 7	MODBUS function code	0x07

Response

Byte	Field name	Example
...		
Byte 7	MODBUS function code	0x07
Byte 8	Reference number	0x00

Exception

Byte	Field name	Example
...		
Byte 7	MODBUS function code	0x85
Byte 8	Exception code	0x01 or 0x02

4.2.3.8 Function Code FC11 (Get comm event counter)

This function returns a status word and an event counter from the slave device's communication event counter. By reading the current count before and after a series of messages, a master can determine whether the messages were handled normally by the slave.

Following each successful new processing, the counter counts up. This counting process is not performed in the case of exception replies, poll commands or counter inquiries.

Request

Byte	Field name	Example
Byte 0, 1	Transaction identifier	0x0000
Byte 2, 3	protocol identifier	0x0000
Byte 4, 5	length field	0x0002
Byte 6	unit identifier	0x01 not used
Byte 7	MODBUS function code	0x0B

Response

The reply contains a 2-byte status word and a 2-byte event counter. The status word only contains zeroes.

Byte	Field name	Example
.....		
Byte 7	MODBUS function code	0x0B
Byte 8, 9	Status	0x0000
Byte 10, 11	Event Count	0x0003

The event counter shows that 3 (0x0003) events were counted.

Exception

Byte	Field name	Example
.....		
Byte 7	MODBUS function code	0x85
Byte 8	Exception code	0x01 or 0x02

4.2.3.9 Function Code FC15 (Force Multiple Coils)

This function sets a sequence of output bits to 1 or 0 in a slave device. The maximum number is 256 bits.

Request

The request message specifies the reference number (first coil in the sequence), the bit count (number of bits to be written), and the output data. The output coils are zero-based; therefore, the first output point is 0.

In this example 16 bits are set, starting with the address 0. The request contains 2 bytes with the value 0xA5F0, or 1010 0101 1111 0000 in binary format.

The first data byte transmits the value of 0xA5 to the addresses 7 to 0, whereby 0 is the lowest value bit. The next byte transmits 0xF0 to the addresses 15 to 8, whereby the lowest value bit is 8.

Byte	Field name	Example
Byte 0, 1	Transaction identifier	0x0000
Byte 2, 3	protocol identifier	0x0000
Byte 4, 5	Length field	0x0009
Byte 6	unit identifier	0x01 not used
Byte 7	MODBUS function code	0x0F
Byte 8, 9	reference number	0x0000
Byte 10, 11	Bit Count	0x0010
Byte 12	Byte Count	0x02
Byte 13	Data Byte1	0xA5
Byte 14	Data Byte2	0xF0

Response

Byte	Field name	Example
.....		
Byte 7	MODBUS function code	0x0F
Byte 8, 9	Reference number	0x0000
Byte 10, 11	Bit Count	0x0010

Exception

Byte	Field name	Example
.....		
Byte 7	MODBUS function code	0x8F
Byte 8	Exception code	0x01 or 0x02

4.2.3.10 Function Code FC16 (Write multiple registers)

This function writes a sequence of registers in a slave device in word format.

Request

The Request specifies the reference number (starting register), the word count (number of registers to write), and the register data . The data is sent as 2 bytes per register. The registers are zero-based; therefore, the first output is at address 0.

Example: Set data in registers 0 and 1:

Byte	Field name	Example
Byte 0, 1	Transaction identifier	0x0000
Byte 2, 3	protocol identifier	0x0000
Byte 4, 5	length field	0x000B
Byte 6	Unit identifier	0x01 not used
Byte 7	MODBUS function code	0x10
Byte 8, 9	reference number	0x0000
Byte 10, 11	Word count	0x0002
Byte 12	Byte Count	0x04
Byte 13, 14	Register Value 1	0x1234
Byte 15, 16	Register Value 2	0x2345

Response

Byte	Field name	Example
.....		
Byte 7	MODBUS function code	0x10
Byte 8, 9	Reference number	0x0000
Byte 10, 11	Word Count	0x0002

Exception

Byte	Field name	Example
.....		
Byte 7	MODBUS function code	0x85
Byte 8	Exception code	0x01 or 0x02

4.2.3.11 Function Code FC23 (Read/Write multiple registers)

This function performs a combination of a read and write operation in a single request. The function can write the new data to a group registers, and then return the data of a different group.

Request

The reference numbers (addresses) are zero-based in the request message; therefore, the first register is at address 0.

The request message specifies the registers to read and write. The data is sent as 2 bytes per register.

Example: The data in register 3 is set to value 0x0123, and values 0x0004 and 0x5678 are read out of the two registers 0 and 1.

Byte	Field name	Example
Byte 0, 1	Transaction identifier	0x0000
Byte 2, 3	protocol identifier	0x0000
Byte 4, 5	length field	0x000F
Byte 6	Unit identifier	0x01 not used
Byte 7	MODBUS function code	0x17
Byte 8-9	reference number for read	0x0000
Byte 10-11	Word count for read (1-125)	0x0002
Byte 12-13	reference number for write	0x0003
Byte 14-15	Word count for write (1-100)	0x0001
Byte 16	Byte Count (B = 2 x word count for write)	0x02
Byte 17-(B+16)	Register Values	0x0123

Response

Byte	Field name	Example
....		
Byte 7	MODBUS function code	0x17
Byte 8	Byte Count (B = 2 x word count for read)	0x04
Byte 9-(B+1)	Register Values	0x0004 0x5678

Exception

Byte	Field name	Example
.....		
Byte 7	MODBUS function code	0x97
Byte 8	Exception code	0x01 or 0x02



Note

If register areas for read and write overlap, the results are undefined.

4.2.4 MODBUS Register Mapping

The following tables display the MODBUS addressing and the corresponding IEC61131 addressing for the process image and the internal variables is represented.

Via the register services the states of the complex and digital I/O modules can be determined or changed.

Register (Word) Access Reading (with FC3 and FC4):

Modbus-Address		IEC61131	Memory Range
[dec]	[hex]	Address	
0 ... 255	0x0000 ... 0x00FF	%IW0 ... %IW255	Physical Input Area
256 ... 511	0x0100 ... 0x01FF	-	Modbus Exception: "Illegal data address"
512 ... 767	0x0200 ... 0x02FF	%QW0 ... %QW255	Physical Output Area
768 ... 4095	0x0300 ... 0x0FFF	-	Modbus Exception: "Illegal data address"
4096 ... 12287	0x1000 ... 0x2FFF	-	Configuration Register (see following Chapter 4.2.5.3 Configuration Functions)
12288 ... 65535	0x3000 ... 0xFFFF	-	Modbus Exception: "Illegal data address"

Register (Word) Access Writing (with FC6 and FC16):

Modbus-Address		IEC61131	Memory Range
[dec]	[hex]	Address	
0 ... 255	0x0000 ... 0x00FF	%QW0 ... %QW255	Physical Output Area
256 ... 511	0x0100 ... 0x01FF	-	Modbus Exception: "Illegal data address"
512 ... 767	0x0200 ... 0x02FF	%QW0 ... %QW255	Physical Output Area
768 ... 4095	0x0300 ... 0x0FFF	-	Modbus Exception: "Illegal data address"
4096 ... 12287	0x1000 ... 0x2FFF	-	Configuration Register (see following Chapter 4.2.5.3 Configuration Functions)
12288 ... 65535	0x3000 ... 0xFFFF	-	Modbus Exception: "Illegal data address"

The digital Modbus services (coil services) are Bit accesses, with which only the states of digital I/O modules can be determined or changed. Complex I/O modules are not attainable with these services and so they are ignored.

Because of this the addressing of the digital channels begins again with 0, so that the MODBUS address is always identical to the channel number, (i.e. the digital input no. 47 has the MODBUS address "46").

Bit Access Reading (with FC1 and FC2):

Modbus-Address		Memory Range	Description
[dec]	[hex]		
0 ... 511	0x0000 ... 0x01FF	Physical Input Area	First 512 digital inputs
512 ... 1023	0x0200 ... 0x03FF	Physical Output Area	First 512 digital outputs
1024 ... 65535	0x0400 ... 0xFFFF		Modbus Exception: "Illegal data address"

Bit Access Writing (with FC5 and FC15):

Modbus-Address		Memory Range	Description
[dec]	[hex]		
0 ... 511	0x0000 ... 0x01FF	Physical Output Area	max 512 digital outputs
512 ... 1023	0x0200 ... 0x03FF	Physical Output Area	max 512 digital outputs
1024 ... 65535	0x0400 ... 0xFFFF		Modbus Exception: "Illegal data address"

4.2.5 Internal Variables

Address	Access	Length (word)	Remark
0x1000	R/W	1	Watchdog-Time read/write
0x1001	R/W	1	Watchdog Coding mask 1-16
0x1002	R/W	1	Watchdog Coding mask 17-32
0x1003	R/W	1	Watchdog Trigger
0x1004	R	1	Minimum Trigger time
0x1005	R/W	1	Watchdog stop (Write sequence 0xAAAA, 0x5555)
0x1006	R	1	Watchdog Status
0x1007	R/W	1	Restart Watchdog (Write sequence 0x1)
0x1008	RW	1	Stop Watchdog (Write sequence 0x55AA or 0xAA55)
0x1009	R/W	1	MODBUS -and HTTP- close at Watchdog Timeout
0x100A	R/W	1	Watchdog configuration
0x1020	R	1-2	LED Error Code
0x1021	R	1	LED Error Argument
0x1022	R	1-4	Number of analog output data in the process image (in bits)
0x1023	R	1-3	Number of analog input data in the process image (in bits)
0x1024	R	1-2	Number of digital output data in the process image (in bits)

0x1025	R	1	Number of digital input data in the process image (in bits)
0x1027	R		Perform an internal bus cycle
0x1028	R/W	1	Boot configuration
0x1029	R	9	MODBUS-TCP statistics
0x1030	R/W	1	Configuration MODBUS/TCP Timeout
0x1031	W	1	Read out the MAC-ID of the coupler
0x2000	R	1	Constant 0x0000
0x2001	R	1	Constant 0xFFFF
0x2002	R	1	Constant 0x1234
0x2003	R	1	Constant 0xAAAA
0x2004	R	1	Constant 0x5555
0x2005	R	1	Constant 0x7FFF
0x2006	R	1	Constant 0x8000
0x2007	R	1	Constant 0x3FFF
0x2008	R	1	Constant 0x4000
0x2010	R	1	Firmware version
0x2011	R	1	Series code
0x2012	R	1	Coupler code
0x2013	R	1	Firmware versions major revision
0x2014	R	1	Firmware versions minor revision
0x2020	R	16	Short description coupler
0x2021	R	8	Compile time of the firmware
0x2022	R	8	Compile date of the firmware
0x2023	R	32	Indication of the firmware loader
0x2030	R	65	Description of the connected busmodules (module 0–64)
0x2040	W	1	Software reset (Write sequence 0x55AA or 0xAA55)

4.2.5.1 Description of the internal variables

4.2.5.1.1 Watchdog (Fieldbus failure)

The watchdog monitors the data transfer between the fieldbus master and the coupler. Every time the coupler receives a specific request (as define in the watchdog setup registers) from the master, the watchdog timer in the coupler resets.

In the case of fault free communication, the watchdog timer does not reach its end value. After each successful data transfer, the timer is reset.

If the watchdog times out, a fieldbus failure has occurred. In this case, the fieldbus coupler answers all following MODBUS TCP/IP requests with the exception code 0x0004 (Slave Device Failure).

In the coupler special registers are use to setup the watchdog by the master (Register addresses 0x1000 to 0x1008).

By default, the watchdog is not enabled when you turn the coupler on. To activate it, the first step is to set/verify the desired time-out value of the Watchdog Time register (0x1000). Second, the function code mask must be specified in the mask register (0x1001), which defines the function code(s) that will reset the timer. Finally, the Watchdog-Trigger register (0x1003) must be changed to a non-zero value to start the timer.

Reading the Minimum Trigger time (Register 0x1004) reveals whether a watchdog fault occurred. If this time value is 0, a fieldbus failure is assumed. The timer of watchdog can manually be reset, if it is not timed out, by writing a value of 0x1 to the Restart Watchdog register (0x1007).

After the watchdog is started, it can be stopped by the user via the Watchdog Stop register (0x1005) or the Simply Stop Watchdog register (0x1008)

4.2.5.1.2 Watchdog Register:

The watchdog registers can be addressed in the same way as described with the MODBUS read and write function codes. Specify the respective register address in place of the reference number.

Register address 0x1000 (MODBUS Address 404097)	
Designation	Watchdog time, WS_TIME
Access	read / write
Default	0x0000
Description	This register stores the watchdog timeout value as an unsigned 16 bit value. The default value is 0. Setting this value will not trigger the watchdog. However, a non zero value must be stored in this register before the watchdog can be triggered. The time value is stored in multiples of 100ms (e.g., 0x0009 is .9 seconds) It is not possible to modify this value while the watchdog is running.

Register address 0x1001 (MODBUS Address 404098)	
Designation	Watchdog function coding mask, function code 1...16, WDFCM_1_161...16
Access	read / write
Default	0x0000
Description	Using this mask, the specific function codes can be configured to reset the watchdog function. The function code can be selected by writing a '1' to the appropriate bit(s) ($2^{(\text{Function code}-1)} + 2^{(\text{Function code}-1\dots)}$). Bit 1001.0 corresponds to function code1, Bit 1001.1 corresponds to function code2... A value of 0xFF enables Modbus functions code 1 through 16 to reset the watchdog. It is not possible to modify this value while the watchdog is running.

Register address 0x1002 (MODBUS Address 404099)	
Designation	Watchdog function coding mask, function code 17...32, WD_FCM_17_32
Access	read / write
Default	0x0000
Description	Same function as above, however, with the function codes 17 to 32. These codes are currently not supported, for this reason the default value should not be changed.. It is not possible to modify this value while the watchdog is running.

Register address 0x1003 (MODBUS Address 404100)	
Designation	Watchdog-Trigger, WD_TRIGGER
Access	read / write
Default	0x0000
Description	This register is used to trigger the watchdog. The default value after power up is 0. The writing of a non zero value will trigger the watchdog. The watchdog is triggered each time the contents of this register are modified. The watchdog cannot be triggered if the watchdog timer register is set to 0.

Register address 0x1004 (MODBUS Address 404101)	
Designation	Minimum current trigger time, WD_AC_TRG_TIME
Access	read / write
Default	0xFFFF
Description	This register stores the time value for the shortest remaining watchdog duration. The default value is 0xFFFF. When the watchdog timer is triggered, this register is continuously compared to the remaining watchdog time, and the lesser of the two values is stored in this register. If the value in this register is 0, a watchdog fault has occurred.

Register address 0x1005 (MODBUS Address 404102)	
Designation	Watchdog stoppen, WD_AC_STOP_MASK
Access	read / write
Default	0x0000
Description	This register is used to stop the watchdog timer by entering a value of 0xAAAA followed by 0x5555.

Register address 0x1006 (MODBUS Address 404103)	
Designation	While watchdog is running, WD_RUNNING
Access	read
Default	0x0000
Description	Current watchdog status. at 0x0000: Watchdog not active, at 0x0001: Watchdog active. at 0x0002: Watchdog exhausted.

Register address 0x1007 (MODBUS Address 404104)	
Designation	Restart watchdog, WD_RESTART
Access	read / write
Default	0x0001
Description	This register restarts the watchdog timer by writing a value of 0x1 into it. If the watchdog was stopped before the overrun, it is not restarted.

Register address 0x1008 (MODBUS Address 404105)	
Designation	Simply stop watchdog WD_AC_STOP_SIMPLE
Access	read / write
Default	0x0000
Description	This register stops the watchdog by writing the value 0x0AA55 or 0X55AA into it. The watchdog timeout fault is deactivated and it is possible to write in the watchdog register again. If there is an existing watchdog fault, it is reset

Register address 0x1009 (MODBUS Address 404106)	
Designation	Close MODBUS socket after watchdog timeout
Access	read / write
Description	0 : MODBUS socket is not closed 1: MODBUS socket is closed

Register address 0x100A (MODBUS Address 404107)	
Designation	Alternative watchdog
Access	read / write
Default	0x0000
Description	This register provides an alternate way to activate the watchdog timer. Procedure: Write a time value in register 0x1000; then write a 0x0001 into register 0x100A. With the first MODBUS request, the watchdog is started. The watchdog timer is reset with each Modbus/TCP instruction. If the watchdog times out, all outputs are set to zero. The outputs will become operational again, after communications are re-established.

All register data is in word format.

Examples:

Set the watchdog for a timeout of 1 second. Function code 5 (Force Single Coil) will be use to reset the watchdog time.

1. Write 0x000A (1000ms /100 ms) in the Watchdog Timer register (0x1000).
2. Write 0x0010 ($2^{(5-1)}$) in the Coding Mask register (0x1001)
3. Modify the value of the Watchdog-Trigger register (0x0003) to start the watchdog.
4. At this point, the fieldbus master must continuously use function code 5 (Force Single Coil) within the specified time to reset the watchdog timer. If time between requests exceeds 1 second, a watchdog timeout error occurs.

To stop the watchdog after it is started, write the value 0x0AA55 or 0X55AA into it the Simply Stop Watchdog register (0x1008).

Set the watchdog for a timeout of 10 minutes. Function code 3 (Read Multiple Registers) will be use to reset the watchdog time.

1. Write 0x1770 (10*60*1000 ms / 100 ms) in the register for time overrun (0x1000).
2. Write 0x0004 ($2^{(3-1)}$) in the Coding Mask register (0x1001)
3. Modify the value of the Watchdog-Trigger register (0x0003) to start the watchdog.
4. At this point, the fieldbus master must continuously use function code 3 (Force Single Coil) within the specified time to reset the watchdog timer. If time between requests exceeds 10 minutes, a watchdog timeout error occurs..

To stop the watchdog after it is started, write the value 0x0AA55 or 0X55AA into it the Simply Stop Watchdog register (0x1008).

4.2.5.2 Diagnostic Functions

The following registers can be read to determine errors in the node:

Register address 0x1020 (MODBUS Address 404129)	
Designation	LedErrCode
Access	read
Description	Declaration of the Error code (see section 3.1.8.4 for error code definitons)

Register address 0x1021 (MODBUS Address 404130)	
Designation	LedErrArg
Access	read
Description	Declaration of the Error argument (see section 3.1.8.4 for error code definitons)

4.2.5.3 Configuration Functions

The following registers contain configuration information of the connected modules:

Register address 0x1022 (MODBUS Address 404131)	
Designation	CnfLen.AnalogOut
Access	read
Description	Number of word-based outputs registers in the process image in bits (divide by 16 to get the total number of analog words)

Register address 0x1023 (MODBUS Address 404132)	
Designation	CnfLen.AnalogInp
Access	read
Description	Number of word-based inputs registers in the process image in bits (divide by 16 to get the total number of analog words)

Register address 0x1024 (MODBUS Address 404133)	
Designation	CnfLen.DigitalOut
Access	read
Description	Number of digital output bits in the process image

Register address 0x1025 (MODBUS Address 404134)	
Designation	CnfLen.DigitalInp
Access	read
Description	Number of digital input bits in the process image

Register address 0x1027 (MODBUS Address 404136)	
Designation	Perform an internal bus cycle
Access	Read
Description	

Register address 0x1028 (MODBUS Address 404137)	
Designation	Activate/deactivate configuration via BootP
Access	read / write
Description	0: No BootP is used 1: BootP is active

Register address 0x1029 (MODBUS Address 404138, with a word count of upto 9)	
Designation	MODBUS TCP statistics
Access	read / write
Description	<p>1 word SlaveDeviceFailure -> internal bus error, F-bus error by activated watchdog</p> <p>1 word BadProtocol; -> error in the MODBUS TCP header</p> <p>1 word BadLength; -> Wrong telegram length</p> <p>2 words BadFunction;M -> Invalid function code</p> <p>2 words Bad Address; -> Invalid register address</p> <p>2 words BadData; -> Invalid value</p> <p>2 words TooManyRegisters; -> Number of the registers which can be worked on is too large, Read/Write 125/100</p> <p>2 words TooManyBits -> Number of the coils which can be worked on is too large, Read/Write 2000/800</p> <p>2 words ModTcpMessageCounter-> Number of received MODBUS/TCP requests</p>
	With Writing 0xAA55 or 0x55AA in the register will reset this data area.

Register address 0x1030 (MODBUS Address 404145, with a word count of 1)	
Designation	Configuration MODBUS/TCP Timeout
Access	read / write
Default	0x0000
Description	This is the maximum number of milliseconds the coupler will allow a Modbus TCP connection to stay open without receiving a Modbus request. Upon timeout, idle connection will be closed. Outputs remain in last state. Default value is 0 (timeout disabled).

Register address 0x1031 (MODBUS Address 404146, with a word count of 3)	
Designation	Read the MAC-ID of the coupler
Access	read
Description	This register gives the MAC-ID, with a length of 3 words

Register address 0x2030 (MODBUS Address 408241, with a word count of upto 65)																																																																																																							
Designation	Description of the connected I/O modules																																																																																																						
Access	Read modules 0 ... 64																																																																																																						
Description	<p>Length 1-65 words</p> <p>These 65 registers identify the coupler and the first 64 modules present in a node. Each module is represented in a word. Because item numbers cannot be read out of digital modules, a code is displayed for them, as defined below:</p> <p>Bit position 0 -> Input module Bit position 1 -> Output module Bit position 2-7 -> not used Bit position 8-14 -> module size in bits Bit position 15 -> Designation digital module</p>																																																																																																						
	<p>Examples:</p> <p>4 Channel Digital Input Module = 0x8401</p> <table border="1"> <tr> <td>bit</td> <td>15</td><td>14</td><td>13</td><td>12</td><td>11</td><td>10</td><td>9</td><td>8</td><td>7</td><td>6</td><td>5</td><td>4</td><td>3</td><td>2</td><td>1</td><td>0</td> </tr> <tr> <td>code</td> <td>1</td><td>0</td><td>0</td><td>0</td><td>0</td><td>1</td><td>0</td><td>0</td><td>0</td><td>0</td><td>0</td><td>0</td><td>0</td><td>0</td><td>0</td><td>1</td> </tr> <tr> <td>hex</td> <td colspan="4">8</td> <td colspan="4">4</td> <td colspan="4">0</td> <td colspan="4">1</td> </tr> </table> <p>2 Channel Digital Output Module = 0x8202</p> <table border="1"> <tr> <td>bit</td> <td>15</td><td>14</td><td>13</td><td>12</td><td>11</td><td>10</td><td>9</td><td>8</td><td>7</td><td>6</td><td>5</td><td>4</td><td>3</td><td>2</td><td>1</td><td>0</td> </tr> <tr> <td>code</td> <td>1</td><td>0</td><td>0</td><td>0</td><td>0</td><td>0</td><td>1</td><td>0</td><td>0</td><td>0</td><td>0</td><td>0</td><td>0</td><td>0</td><td>1</td><td>0</td> </tr> <tr> <td>hex</td> <td colspan="4">8</td> <td colspan="4">2</td> <td colspan="4">0</td> <td colspan="4">2</td> </tr> </table>	bit	15	14	13	12	11	10	9	8	7	6	5	4	3	2	1	0	code	1	0	0	0	0	1	0	0	0	0	0	0	0	0	0	1	hex	8				4				0				1				bit	15	14	13	12	11	10	9	8	7	6	5	4	3	2	1	0	code	1	0	0	0	0	0	1	0	0	0	0	0	0	0	1	0	hex	8				2				0				2			
bit	15	14	13	12	11	10	9	8	7	6	5	4	3	2	1	0																																																																																							
code	1	0	0	0	0	1	0	0	0	0	0	0	0	0	0	1																																																																																							
hex	8				4				0				1																																																																																										
bit	15	14	13	12	11	10	9	8	7	6	5	4	3	2	1	0																																																																																							
code	1	0	0	0	0	0	1	0	0	0	0	0	0	0	1	0																																																																																							
hex	8				2				0				2																																																																																										

Register address 0x2040 (MODBUS Address 408257)	
Designation	Implement a software reset
Access	write (Write sequence 0xAA55 or 0x55AA)
Description	With Writing 0xAA55 or 0x55AA the register will be reset.

4.2.5.4 Firmware Information

The following registers contain information on the firmware of the coupler:

Register address 0x2010 (MODBUS Address 408209, with a word count of 1)	
Designation	Revision, INFO_REVISION
Access	Read
Description	Firmware Index, e. g. 0005 for version 5

Register address 0x2011 (MODBUS Address 408210, with a word count of 1)	
Value	Series code, INFO_SERIES
Access	Read
Description	WAGO serial number, e. g. 0750 for WAGO-I/O-SYSTEM 750

Register address 0x2012 (MODBUS Address 408211, with a word count of 1)	
Value	Item number, INFO_ITEM
Access	Read
Description	WAGO item number, e. g. 342 for the coupler

Register address 0x2013 (MODBUS Address 408212, with a word count of 1)	
Value	Major sub item code, INFO_MAJOR
Access	read
Description	Firmware version Major Revision

Register address 0x2014 (MODBUS Address 408213, with a word count of 1)	
Value	Minor sub item code, INFO_MINOR
Access	read
Description	Firmware version Minor Revision

Register address 0x2020 (MODBUS Address 408225, with a word count of upto 16)	
Value	Description, INFO_DESCRIPTION
Access	Read
Description	Information on the coupler, 16 words

Register address 0x2021 (MODBUS Address 408226, with a word count of upto 8)	
Value	Description, INFO_DESCRIPTION
Access	Read
Description	Time of the firmware version, 8 words

Register address 0x2022 (MODBUS Address 408227, with a word count of upto 8)	
Value	Description, INFO_DATE
Access	Read
Description	Date of the firmware version, 8 words

Register address 0x2023 (MODBUS Address 408228, with a word count of upto 32)	
Value	Description, INFO_LOADER_INFO
Access	read
Description	Information to the programming of the firmware, 32 words

4.2.5.5 Constant Registers

The following registers contain constants, which can be used to test communication with the master:

Register address 0x2000 (MODBUS Address 408193)	
Value	Zero, GP_ZERO
Access	Read
Description	Constant with zeros

Register address 0x2001 (MODBUS Address 408194)	
Value	Ones, GP_ONES
Access	Read
Description	Constant with ones. Is -1 if this is declared as "signed int" or MAXVALUE if it is declared as "unsigned int".

Register address 0x2002 (MODBUS Address 408195)	
Value	1,2,3,4, GP_1234
Access	Read
Description	This constant value is used to test the Intel/Motorola format specifier. If the master reads a value of 0x1234, then with Intel format is selected – this is the correct format. If 0x3412 appears, Motorola format is selected.

Register address 0x2003 (MODBUS Address 408196)	
Value	Mask 1, GP_AAAA
Access	Read
Description	This constant is used to verify that all bits are accessible to the fieldbus master. This will be used together with register 0x2004.

Register address 0x2004 (MODBUS Address 408197)	
Value	Mask 1, GP_5555
Access	Read
Description	This constant is used to verify that all bits are accessible to the fieldbus master. This will be used together with register 0x2003.

Register address 0x2005 (MODBUS Address 408198)	
Value	Maximum positiv number, GP_MAX_POS
Access	Read
Description	Constant in order to control arithmetic.

Register address 0x2006 (MODBUS Address 408199)	
Value	Maximum negativ number, GP_MAX_NEG
Access	Read
Description	Constant in order to control arithmetic.

Register address 0x2007 (MODBUS Address 408200)	
Value	Maximum half positiv number, GP_HALF_POS
Access	Read
Description	Constant in order to control arithmetic.

Register address 0x2008 (MODBUS Address 408201)	
Value	Maximum half negativ number, GP_HALF_NEG
Access	Read
Description	Constant in order to control arithmetic.

5 I/O Modules

5.1 Overview

All listed bus modules, in the overview below, are available for modular applications with the WAGO-I/O-SYSTEM 750.

For detailed information on the I/O modules and the module variations, please refer to the manuals for the I/O modules.

You will find these manuals on CD ROM „ELECTRONICC Tools and Docs“ (Item-no.: 0888-0412) or on the web pages:

www.wago.com → Service → Download → Documentation.



More Information

Current information on the modular WAGO-I/O-SYSTEM is available in the Internet under:

www.wago.com

5.1.1 Digital Input Modules

DI DC 5 V	
750-414	4 Channel, DC 5 V, 0.2 ms, 2- to 3-conductor connection, high-side switching
DI DC 5(12) V	
753-434	8 Channel, DC 5(12) V, 0.2 ms, 1-conductor connection, high-side switching
DI DC 24 V	
750-400, 753-400	2 Channel, DC 24 V, 3.0 ms, 2- to 4-conductor connection; high-side switching
750-401, 753-401	2 Channel, DC 24 V, 0.2 ms, 2- to 4-conductor connection; high-side switching
750-410, 753-410	2 Channel, DC 24 V, 3.0 ms, 2- to 4-conductor connection; high-side switching
750-411, 753-411	2 Channel, DC 24 V, 0.2 ms, 2- to 4-conductor connection; high-side switching
750-418, 753-418	2 Channel, DC 24 V, 3.0 ms, 2- to 3-conductor connection; high-side switching; diagnostic
750-419	2 Channel, DC 24 V, 3.0 ms, 2- to 3-conductor connection; high-side switching; diagnostic
750-421, 753-421	2 Channel, DC 24 V, 3.0 ms, 2- to 3-conductor connection; high-side switching; diagnostic
750-402, 753-402	4 Channel, DC 24 V, 3.0 ms, 2- to 3-conductor connection; high-side switching
750-432, 753-432	4 Channel, DC 24 V, 3.0 ms, 2-conductor connection; high-side switching
750-403, 753-403	4 Channel, DC 24 V, 0.2 ms, 2- to 3-conductor connection; high-side switching

750-433, 753-433	4 Channel, DC 24 V, 0.2 ms, 2-conductor connection; high-side switching
750-422, 753-422	4 Channel, DC 24 V, 2- to 3-conductor connection; high-side switching; 10 ms pulse extension
750-408, 753-408	4 Channel, DC 24 V, 3.0 ms, 2- to 3-conductor connection; low-side switching
750-409, 753-409	4 Channel, DC 24 V, 0.2 ms, 2- to 3-conductor connection; low-side switching
750-430, 753-430	8 Channel, DC 24 V, 3.0 ms, 1-conductor connection; high-side switching
750-431, 753-431	8 Channel, DC 24 V, 0.2 ms, 1-conductor connection; high-side switching
750-436	8 Channel, DC 24 V, 3.0 ms, 1-conductor connection; lowside switching
750-437	8 Channel, DC 24 V, 0.2 ms, 1-conductor connection; low-side switching
DI AC/DC 24 V	
750-415, 753-415	4 Channel, AC/DC 24 V, 2-conductor connection
750-423, 753-423	4 Channel, AC/DC 24 V, 2- to 3-conductor connection; with power jumper contacts
DI AC/DC 42 V	
750-428, 753-428	4 Channel, AC/DC 42 V, 2-conductor connection
DI DC 48 V	
750-412, 753-412	2 Channel, DC 48 V, 3.0ms, 2- to 4-conductor connection; high-side switching
DI DC 110 V	
750-427, 753-427	2 Channel, DC 110 V, Configurable high-side or low-side switching
DI AC 120 V	
750-406, 753-406	2 Channel, AC 120 V, 2- to 4-conductor connection; high-side switching
DI AC 120(230) V	
753-440	4 Channel, AC 120(230) V, 2-conductor connection; high-side switching
DI AC 230 V	
750-405, 753-405	2 Channel, AC 230 V, 2- to 4-conductor connection; high-side switching
DI NAMUR	
750-435	1 Channel, NAMUR EEx i, Proximity switch acc. to DIN EN 50227
750-425, 753-425	2 Channel, NAMUR, Proximity switch acc. to DIN EN 50227
750-438	2 Channel, NAMUR EEx i, Proximity switch acc. to DIN EN 50227
DI Intruder Detection	
750-424, 753-424	2 Channel, DC 24 V, Intruder Detection

5.1.2 Digital Output Modules

DO DC 5 V	
750-519	4 Channel, DC 5 V, 20mA, short-circuit-protected; high-side switching
DO DC 12(14) V	
753-534	8 Channel, DC 12(14) V, 1A, short-circuit-protected; high-side switching
DO DC 24 V	
750-501, 753-501	2 Channel, DC 24 V, 0.5 A, short-circuit-protected; high-side switching
750-502, 753-502	2 Channel, DC 24 V, 2.0 A, short-circuit-protected; high-side switching
750-506, 753-506	2 Channel, DC 24 V, 0.5 A, short-circuit-protected; high-side switching; with diagnostics
750-507, 753-507	2 Channel, DC 24 V, 2.0 A, short-circuit-protected; high-side switching; with diagnostics; No longer available, replaced by 750-508
750-508	2 Channel, DC 24 V, 2.0 A, short-circuit-protected; high-side switching; with diagnostics; Replacement for 750-508
750-535	2 Channel, DC 24 V, EEx i, short-circuit-protected; PNP-positive switching
750-504, 753-504	4 Channel, DC 24 V, 0.5 A, short-circuit-protected; high-side switching
750-531, 753-531	4 Channel, DC 24 V, 0.5 A, short-circuit-protected; high-side switching
750-516, 753-516	4 Channel, DC 24 V, 0.5 A, short-circuit-protected; low-side switching
750-530, 753-530	8 Channel, DC 24 V, 0.5 A, short-circuit-protected; high-side switching
750-537	8 Channel, DC 24 V, 0.5 A, short-circuit-protected; high-side switching; with diagnostics
750-536	8 Channel, DC 24 V, 0.5 A, short-circuit-protected; low-side switching
DO AC 120(230) V	
753-540	4 Channel, AC 120(230) V, 0.25 A, short-circuit-protected; high-side switching
DO AC/DC 230 V	
750-509, 753-509	2 Channel Solid State Relay, AC/DC 230 V, 300 mA
750-522	2 Channel Solid State Relay, AC/DC 230 V, 500 mA, 3 A (< 30 s)
DO Relay	
750-523	1 Channel, AC 230 V, AC 16 A, isolated output, 1 make contact, bistable, manual operation
750-514, 753-514	2 Channel, AC 125 V, AC 0.5 A, DC 30 V, DC 1 A, isolated outputs, 2 changeover contacts
750-517, 753-517	2 Channel, AC 230 V, 1 A, isolated outputs, 2 changeover contacts
750-512, 753-512	2 Channel, AC 230 V, DC 30 V, AC/DC 2 A, non-floating, 2 make contacts
750-513, 753-513	2 Channel, AC 230 V, DC 30 V, AC/DC 2 A, isolated outputs, 2 make contacts

5.1.3 Analog Input Modules

AI 0 - 20 mA	
750-452, 753-452	2 Channel, 0 - 20 mA, Differential Inputs
750-465, 753-465	2 Channel, 0 - 20 mA, single-ended (S.E.)
750-472, 753-472	2-channel, 0 - 20 mA, 16 Bit, single-ended (S.E.)
750-480	2-channel, 0 - 20 mA ,Differential Inputs
750-453, 753-453	4 Channel, 0 - 20 mA, single-ended (S.E.)
AI 4 - 20 mA	
750-454, 753-454	2 Channel, 4 - 20 mA,Differential Inputs
750-474, 753-474	2 Channel, 4 - 20 mA, 16 Bit, single-ended (S.E.)
750-466, 753-466	2 Channel, 4 - 20 mA, single ended (S.E.)
750-485	2 Channel, 4 - 20 mA, EEx i, single ended (S.E.)
750-492, 753-492	2 Channel, 4 - 20 mA, Isolated Differential Inputs
750-455, 753-455	4 Channel, 4 - 20 mA, single ended (S.E.)
AI 0 - 1 A	
750-475, 753-475	2-channel, 0 - 1 A AC/DC ,Differential Inputs
AI 0 - 5 A	
750-475/020-000, 753-475/020-000	2-channel, 0 - 5 A AC/DC ,Differential Inputs
AI 0 - 10 V	
750-467, 753-467	2 Channel, DC 0 - 10 V, single-ended (S.E.)
750-477, 753-477	2 Channel, AC/DC 0 - 10 V,Differential Inputs
750-478, 753-478	2 Channel, DC 0 - 10 V, single-ended (S.E.)
750-459, 753-459	4 Channel, DC 0 - 10 V, single-ended (S.E.)
750-468	4 Channel, DC 0 - 10 V, single-ended (S.E.)
AI DC ± 10 V	
750-456, 753-456	2 Channel, DC ± 10 V,Differential Inputs
750-479, 753-479	2 Channel, DC ± 10 V,Differential Measurement Input
750-476, 753-476	2 Channel, DC ± 10 V, single-ended (S.E.)
750-457, 753-457	4 Channel, DC ± 10 V, single-ended (S.E.)
AI DC 0 - 30 V	
750-483, 753-483	2 Channel, DC 0 -30 V,Differential Measurement Input
AI Resistance Sensors	
750-461, 753-461	2 Channel, Resistance Sensors, PT100 / RTD
750-481/003-000	2 Channel, Resistance Sensors, PT100 / RTD, EEx i
750-460	4 Channel, Resistance Sensors, PT100 / RTD
AI Thermocouples	

750-462	2 Channel, thermocouples with diagnostics Sensor types: J, K, B, E, N, R, S, T, U
750-469, 753-469	2 Channel, thermocouples with diagnostics Sensor types: J, K, B, E, N, R, S, T, U, L
AI Others	
750-491	1 Channel for Resistor Bridges (Strain Gauge)

5.1.4 Analog Output Modules

AO 0 - 20 mA	
750-552, 753-552	2 Channel, 0 - 20 mA
750-585	2 Channel, 0 - 20 mA, EEx i
750-553, 753-553	4 Channel, 0 - 20 mA
AO 4 - 20 mA	
750-554, 753-554	2-channel, 4 - 20 mA
750-554, 753-554	4-channel, 4 - 20 mA
AO DC 0 - 10 V	
750-550, 753-550	2 Channel, DC 0 - 10 V
750-560	2 Channel, DC 0 - 10 V, 10 Bit, 100 mW, 24 V
750-559, 753-559	4 Channel, DC 0 - 10 V
AO DC ± 10 V	
750-556, 753-556	2 Channel, DC ± 10 V
750-557, 753-557	4 Channel, DC ± 10 V

5.1.5 Special Modules

Counter Modules	
750-404, 753-404	Up / Down Counter, DC 24 V, 100 kHz
750-638, 753-638	2 Channel, Up / Down Counter, DC 24 V/ 16Bit / 500 Hz
Frequency Measuring	
750-404/000-003, 753-404/000-003	Frequency Measuring
Pulse Width Module	
750-511	2-channel Pulse Width Module, DC 24 V, short-circuit-protected, high-side switching
Distance and Angle Measurement Modules	
750-630	SSI Transmitter Interface
750-631	Incremental Encor Interface, TTL level squarewave
750-634	Incremental Encor Interface, DC 24 V
750-637	Incremental Encor Interface RS 422, cam outputs
750-635, 753-635	Digital Pulse Interface
Serial Interfaces	
750-650, 753	Serial Interface RS 232 C
750-653, 753	Serial Interface RS 485
750-651	TTY-Serial Interface, 20 mA Current Loop
750-654	Data Exchange Module
DALI / DSI Master Module	
750-641	DALI / DSI Master Module
AS interface Master Module	
750-655	AS interface Master Module
Radio Receiver Module	
750-642	Radio Receiver EnOcean
MP Bus Master Module	
750-643	MP Bus (Multi Point Bus) Master Module
Vibration Monitoring	
750-645	2-Channel Vibration Velocity / Bearing Condition Monitoring VIB I/O
PROFIsafe Modules	
750-660/000-001	8FDI 24V DC PROFIsafe
750-665/000-001	4FDO 0.5A / 4FDI 24V DC PROFIsafe
750-666/000-001	1FDO 10A / 2FDO 0.5A / 2FDI 24V PROFIsafe
RTC Module	
750-640	RTC Module

5.1.6 System Modules

Module Bus Extension	
750-627	Module Bus Extension, End Module
750-628	Module Bus Extension, Coupler Module
DC 24 V Power Supply Modules	
750-602	DC 24 V, passiv
750-601	DC 24 V, max. 6.3 A, without diagnostics, with fuse-holder
750-610	DC 24 V, max. 6.3 A, with diagnostics, with fuse-holder
750-625	DC 24 V, EEx i, with fuse-holder
DC 24 V Power Supply Modules with bus power supply	
750-613	Bus power supply, 24 V DC
AC 120 V Power Supply Modules	
750-615	AC 120 V, max. 6.3 A without diagnostics, with fuse-holder
AC 230 V Power Supply Modules	
750-612	AC/DC 230 V without diagnostics, passiv
750-609	AC 230 V, max. 6.3 A without diagnostics, with fuse-holder
750-611	AC 230 V, max. 6.3 A with diagnostics, with fuse-holder
Filter Modules	
750-624	Filter Module for field side power supply
750-626	Filter Module for system and field side power supply
Field Side Connection Module	
750-603, 753-603	Field Side Connection Module, DC 24 V
750-604, 753-604	Field Side Connection Module, DC 0 V
750-614, 753-614	Field Side Connection Module, AC/DC 0 ... 230 V
Separation Modules	
750-616	Separation Module
750-621	Separation Module with Power Contacts
Binary Spacer Module	
750-622	Binary Spacer Module
End Module	
750-600	End Module, to loop the internal bus

5.2 Process Data Architecture for MODBUS/TCP

With some I/O modules, the structure of the process data is fieldbus specific.

In the case of a coupler/controller with MODBUS/TCP, the process image uses a word structure (with word alignment). The internal mapping method for data greater than one byte conforms to the Intel format.

The following section describes the process image for various WAGO-I/O-SYSTEM 750 and 753 I/O modules when using a coupler/controller with MODBUS/TCP.



Note

Depending on the specific position of an I/O module in the fieldbus node, the process data of all previous byte or bit-oriented modules must be taken into account to determine its location in the process data map.

For the PFC process image of the programmable fieldbus controller is the the structure of the process data mapping identical.

5.2.1 Digital Input Modules

Digital input modules supply one bit of data per channel to specify the signal state for the corresponding channel. These bits are mapped into the Input Process Image.

When analog input modules are also present in the node, the digital data is always appended after the analog data in the Input Process Image, grouped into bytes.

Some digital modules have an additional diagnostic bit per channel in the Input Process Image. The diagnostic bit is used for detecting faults that occur (e.g., wire breaks and/or short circuits).

1 Channel Digital Input Module with Diagnostics

750-435

Input Process Image							
Bit 7	Bit 6	Bit 5	Bit 4	Bit 3	Bit 2	Bit 1	Bit 0
						Diagnostic bit S 1	Data bit DI 1

2 Channel Digital Input Modules

750-400, -401, -405, -406, -410, -411, -412, -427, -438, (and all variations),
753-400, -401, -405, -406, -410, -411, -412, -427

Input Process Image							
Bit 7	Bit 6	Bit 5	Bit 4	Bit 3	Bit 2	Bit 1	Bit 0
						Data bit DI 2 Channel 2	Data bit DI 1 Channel 1

2 Channel Digital Input Modules with Diagnostics

750-419, -421, -424, -425, 753-421, -424, -425

Input Process Image							
Bit 7	Bit 6	Bit 5	Bit 4	Bit 3	Bit 2	Bit 1	Bit 0
				Diagnostic bit S 2 Channel 2	Diagnostic bit S 1 Channel 1	Data bit DI 2 Channel 2	Data bit DI 1 Channel 1

2 Channel Digital Input Module with Diagnostics and Output Process Data

750-418, 753-418

The 750-418, 753-418 digital input module supplies a diagnostic and acknowledge bit for each input channel. If a fault condition occurs, the diagnostic bit is set. After the fault condition is cleared, an acknowledge bit must be set to re-activate the input. The diagnostic data and input data bit is mapped in the Input Process Image, while the acknowledge bit is in the Output Process Image.

Input Process Image							
Bit 7	Bit 6	Bit 5	Bit 4	Bit 3	Bit 2	Bit 1	Bit 0
				Diagnostic bit S 2 Channel 2	Diagnostic bit S 1 Channel 1	Data bit DI 2 Channel 2	Data bit DI 1 Channel 1

Output Process Image							
Bit 7	Bit 6	Bit 5	Bit 4	Bit 3	Bit 2	Bit 1	Bit 0
				Acknowledge ment bit Q 2 Channel 2	Acknowledg ement bit Q 1 Channel 1	0	0

4 Channel Digital Input Modules

750-402, -403, -408, -409, -414, -415, -422, -423, -428, -432, -433,
753-402, -403, -408, -409, -415, -422, -423, -428, -432, -433, -440

Input Process Image							
Bit 7	Bit 6	Bit 5	Bit 4	Bit 3	Bit 2	Bit 1	Bit 0
				Data bit DI 4 Channel 4	Data bit DI 3 Channel 3	Data bit DI 2 Channel 2	Data bit DI 1 Channel 1

8 Channel Digital Input Modules

750-430, -431, -436, -437, 753-430, -431, -434

Input Process Image							
Bit 7	Bit 6	Bit 5	Bit 4	Bit 3	Bit 2	Bit 1	Bit 0
Data bit DI 8 Channel 8	Data bit DI 7 Channel 7	Data bit DI 6 Channel 6	Data bit DI 5 Channel 5	Data bit DI 4 Channel 4	Data bit DI 3 Channel 3	Data bit DI 2 Channel 2	Data bit DI 1 Channel 1

5.2.2 Digital Output Modules

Digital output modules use one bit of data per channel to control the output of the corresponding channel. These bits are mapped into the Output Process Image.

When analog output modules are also present in the node, the digital image data is always appended after the analog data in the Output Process Image, grouped into bytes.

1 Channel Digital Output Module with Input Process Data

750-523

Input Process Image							
Bit 7	Bit 6	Bit 5	Bit 4	Bit 3	Bit 2	Bit 1	Bit 0
						not used	Status bit „Manual Operation“

Output Process Image							
Bit 7	Bit 6	Bit 5	Bit 4	Bit 3	Bit 2	Bit 1	Bit 0
						not used	controls DO 1 Channel 1

2 Channel Digital Output Modules

750-501, -502, -509, -512, -513, -514, -517, -535, (and all variations),
 753-501, -502, -509, -512, -513, -514, -517

Output Process Image							
Bit 7	Bit 6	Bit 5	Bit 4	Bit 3	Bit 2	Bit 1	Bit 0
						controls DO 2 Channel 2	controls DO 1 Channel 1

2 Channel Digital Input Modules with Diagnostics and Input Process Data

750-507 (-508), -522, 753-507

The 750-507 (-508), -522 and 753-507 digital output modules have a diagnostic bit for each output channel. When an output fault condition occurs (i.e., overload, short circuit, or broken wire), a diagnostic bit is set. The diagnostic data is mapped into the Input Process Image, while the output control bits are in the Output Process Image.

Input Process Image							
Bit 7	Bit 6	Bit 5	Bit 4	Bit 3	Bit 2	Bit 1	Bit 0
						Diagnostic bit S 2 Channel 2	Diagnostic bit S 1 Channel 1

Output Process Image							
Bit 7	Bit 6	Bit 5	Bit 4	Bit 3	Bit 2	Bit 1	Bit 0
						controls DO 2 Channel 2	controls DO 1 Channel 1

750-506, 753-506

The 750-506, 753-506 digital output module has 2-bits of diagnostic information for each output channel. The 2-bit diagnostic information can then be decoded to determine the exact fault condition of the module (i.e., overload, a short circuit, or a broken wire). The 4-bits of diagnostic data are mapped into the Input Process Image, while the output control bits are in the Output Process Image.

Input Process Image							
Bit 7	Bit 6	Bit 5	Bit 4	Bit 3	Bit 2	Bit 1	Bit 0
				Diagnostic bit S 3 Channel 2	Diagnostic bit S 2 Channel 2	Diagnostic bit S 1 Channel 1	Diagnostic bit S 0 Channel 1

Output Process Image							
Bit 7	Bit 6	Bit 5	Bit 4	Bit 3	Bit 2	Bit 1	Bit 0
				not used	not used	controls DO 2 Channel 2	controls DO 1 Channel 1

4 Channel Digital Output Modules

750-504, -516, -519, -531, 753-504, -516, -531, -540

Output Process Image							
Bit 7	Bit 6	Bit 5	Bit 4	Bit 3	Bit 2	Bit 1	Bit 0
				controls DO 4 Channel 4	controls DO 3 Channel 3	controls DO 2 Channel 2	controls DO 1 Channel 1

4 Channel Digital Output Modules with Diagnostics and Input Process Data

750-532

The 750-532 digital output modules have a diagnostic bit for each output channel. When an output fault condition occurs (i.e., overload, short circuit, or broken wire), a diagnostic bit is set. The diagnostic data is mapped into the Input Process Image, while the output control bits are in the Output Process Image.

Input Process Image							
Bit 7	Bit 6	Bit 5	Bit 4	Bit 3	Bit 2	Bit 1	Bit 0
				Diagnost ic bit S 3 Channel 4	Diagnost ic bit S 2 Channel 3	Diagnost ic bit S 1 Channel 2	Diagnost ic bit S 0 Channel 1

Diagnostic bit S = '0' no Error

Diagnostic bit S = '1' overload, short circuit, or broken wire

Output Process Image							
Bit 7	Bit 6	Bit 5	Bit 4	Bit 3	Bit 2	Bit 1	Bit 0
				controls DO 4 Channel 4	controls DO 3 Channel 3	controls DO 2 Channel 2	controls DO 1 Channel 1

8 Channel Digital Output Module

750-530, -536, 753-530, -434

Output Process Image							
Bit 7	Bit 6	Bit 5	Bit 4	Bit 3	Bit 2	Bit 1	Bit 0
controls DO 8 Channel 8	controls DO 7 Channel 7	controls DO 6 Channel 6	controls DO 5 Channel 5	controls DO 4 Channel 4	controls DO 3 Channel 3	controls DO 2 Channel 2	controls DO 1 Channel 1

8 Channel Digital Output Modules with Diagnostics and Input Process Data

750-537

The 750-537 digital output modules have a diagnostic bit for each output channel. When an output fault condition occurs (i.e., overload, short circuit, or broken wire), a diagnostic bit is set. The diagnostic data is mapped into the Input Process Image, while the output control bits are in the Output Process Image.

Input Process Image							
Bit 7	Bit 6	Bit 5	Bit 4	Bit 3	Bit 2	Bit 1	Bit 0
Diagnostic bit S 7 Channel 8	Diagnostic bit S 6 Channel 7	Diagnostic bit S 5 Channel 6	Diagnostic bit S 4 Channel 5	Diagnostic bit S 3 Channel 4	Diagnostic bit S 2 Channel 3	Diagnostic bit S 1 Channel 2	Diagnostic bit S 0 Channel 1

Diagnostic bit S = '0' no Error
Diagnostic bit S = '1' overload, short circuit, or broken wire

Output Process Image							
Bit 7	Bit 6	Bit 5	Bit 4	Bit 3	Bit 2	Bit 1	Bit 0
controls DO 8 Channel 8	controls DO 7 Channel 7	controls DO 6 Channel 6	controls DO 5 Channel 5	controls DO 4 Channel 4	controls DO 3 Channel 3	controls DO 2 Channel 2	controls DO 1 Channel 1

5.2.3 Analog Input Modules

The hardware of an analog input module has 16 bits of measured analog data per channel and 8 bits of control/status. However, the coupler/controller with MODBUS/TCP does not have access to the 8 control/status bits. Therefore, the coupler/controller with MODBUS/TCP can only access the 16 bits of analog data per channel, which are grouped as words and mapped in Intel format in the Input Process Image.

When digital input modules are also present in the node, the analog input data is always mapped into the Input Process Image in front of the digital data.

1 Channel Analog Input Module

750-491, (and all variations)

Input Process Image			
Offset	Byte Destination		Remark
	High Byte	Low Byte	
0	D1	D0	Measured Value U_D
1	D3	D2	Measured Value U_{ref}

2 Channel Analog Input Modules

750-452, -454, -456, -461, -462, -465, -466, -467, -469, -472, -474, -475, -476, -477, -478, -479, -480, -481, -483, -485, -492, (and all variations),
753-452, -454, -456, -461, -465, -466, -467, -469, -472, -474, -475, -476, -477, -478, -479, -483, -492, (and all variations)

Input Process Image			
Offset	Byte Destination		Remark
	High Byte	Low Byte	
0	D1	D0	Measured Value Channel 1
1	D3	D2	Measured Value Channel 2

4 Channel Analog Input Modules

750-453, -455, -457, -459, -460, -468, (and all variations),
753-453, -455, -457, -459

Input Process Image			
Offset	Byte Destination		Remark
	High Byte	Low Byte	
0	D1	D0	Measured Value Channel 1
1	D3	D2	Measured Value Channel 2
2	D5	D4	Measured Value Channel 3
3	D7	D6	Measured Value Channel 4

5.2.4 Analog Output Modules

The hardware of an analog output module has 16 bits of measured analog data per channel and 8 bits of control/status. However, the coupler/controller with MODBUS/TCP does not have access to the 8 control/status bits. Therefore, the coupler/controller with MODBUS/TCP can only access the 16 bits of analog data per channel, which are grouped as words and mapped in Intel format in the Output Process Image.

When digital output modules are also present in the node, the analog output data is always mapped into the Output Process Image in front of the digital data.

2 Channel Analog Output Modules

750-550, -552, -554, -556, -560, -585, (and all variations),
753-550, -552, -554, -556

Output Process Image			
Offset	Byte Destination		Remark
	High Byte	Low Byte	
0	D1	D0	Output Value Channel 1
1	D3	D2	Output Value Channel 2

4 Channel Analog Output Modules

750-553, -555, -557, -559, 753-553, -555, -557, -559

Output Process Image			
Offset	Byte Destination		Remark
	High Byte	Low Byte	
0	D1	D0	Output Value Channel 1
1	D3	D2	Output Value Channel 2
2	D5	D4	Output Value Channel 3
3	D7	D6	Output Value Channel 4

5.2.5 Specialty Modules

WAGO has a host of Specialty I/O modules that perform various functions. With individual modules beside the data bytes also the control/status byte is mapped in the process image. The control/status byte is required for the bi-directional data exchange of the module with the higher-ranking control system. The control byte is transmitted from the control system to the module and the status byte from the module to the control system.

This allows, for example, setting of a counter with the control byte or displaying of overshooting or undershooting of the range with the status byte.



Further information

For detailed information about the structure of a particular module's control/status byte, please refer to that module's manual. Manuals for each module can be found on the Internet under:
<http://www.wago.com>.

Counter Modules

750-404, (and all variations except of /000-005),
 753-404, (and variation /000-003)

The above Counter Modules have a total of 5 bytes of user data in both the Input and Output Process Image (4 bytes of counter data and 1 byte of control/status). The counter value is supplied as 32 bits. The following tables illustrate the Input and Output Process Image, which has a total of 3 words mapped into each image. Word alignment is applied.

Input Process Image			
Offset	Byte Destination		Remark
	High Byte	Low Byte	
0	-	S	Status byte
1	D1	D0	Counter Value
2	D3	D2	

Output Process Image			
Offset	Byte Destination		Remark
	High Byte	Low Byte	
0	-	C	Control byte
1	D1	D0	Counter Setting Value
2	D3	D2	

750-404/000-005

The above Counter Modules have a total of 5 bytes of user data in both the Input and Output Process Image (4 bytes of counter data and 1 byte of control/status). The two counter values are supplied as 16 bits. The following tables illustrate the Input and Output Process Image, which has a total of 3 words mapped into each image. Word alignment is applied.

Input Process Image			
Offset	Byte Destination		Remark
	High Byte	Low Byte	
0	-	S	Status byte
1	D1	D0	Counter Value of Counter 1
2	D3	D2	Counter Value of Counter 2

Output Process Image			
Offset	Byte Destination		Remark
	High Byte	Low Byte	
0	-	C	Control byte
1	D1	D0	Counter Setting Value of Counter 1
2	D3	D2	Counter Setting Value of Counter 2

750-638, 753-638

The above Counter Modules have a total of 6 bytes of user data in both the Input and Output Process Image (4 bytes of counter data and 2 bytes of control/status). The two counter values are supplied as 16 bits. The following tables illustrate the Input and Output Process Image, which has a total of 4 words mapped into each image. Word alignment is applied.

Input Process Image			
Offset	Byte Destination		Remark
	High Byte	Low Byte	
0	-	S0	Status byte of Counter 1
1	D1	D0	Counter Value of Counter 1
2	-	S1	Status byte of Counter 2
3	D3	D2	Counter Value of Counter 2

Output Process Image			
Offset	Byte Destination		Remark
	High Byte	Low Byte	
0	-	C0	Control byte of Counter 1
1	D1	D0	Counter Setting Value of Counter 1
2	-	C1	Control byte of Counter 2
3	D3	D2	Counter Setting Value of Counter 2

Pulse Width Modules

750-511, (and all variations)

The above Pulse Width modules have a total of 6 bytes of user data in both the Input and Output Process Image (4 bytes of channel data and 2 bytes of control/status). The two channel values are supplied as 16 bits. Each channel has its own control/status byte. The following table illustrates the Input and Output Process Image, which has a total of 4 words mapped into each image. Word alignment is applied.

Input and Output Process Image			
Offset	Byte Destination		Remark
	High Byte	Low Byte	
0	-	C0/S0	Control/Status byte of Channel 1
1	D1	D0	Data Value of Channel 1
2	-	C1/S1	Control/Status byte of Channel 2
3	D3	D2	Data Value of Channel 2

Serial Interface Modules with alternative Data Format

750-650, (and the variations /000-002, -004, -006, -009, -010, -011, -012, -013)

750-651, (and the variations /000-002, -003)

750-653, (and the variations /000-002, -007)



Note:

With the freely parametrizable variations /003 000 of the serial interface modules, the desired operation mode can be set. Dependent on it, the process image of these modules is then the same, as from the appropriate variation.

The above Serial Interface Modules with alternative data format have a total of 4 bytes of user data in both the Input and Output Process Image (3 bytes of serial data and 1 byte of control/status). The following table illustrates the Input and Output Process Image, which have a total of 2 words mapped into each image. Word alignment is applied.

Input and Output Process Image				
Offset	Byte Destination		Remark	
	High Byte	Low Byte		
0	D0	C/S	Data byte	Control/Status byte
1	D2	D1	Data bytes	

Serial Interface Modules with Standard Data Format

750-650/000-001, -014, -015, -016

750-651/000-001

750-653/000-001, -006

The above Serial Interface Modules with Standard Data Format have a total of 6 bytes of user data in both the Input and Output Process Image (5 bytes of serial data and 1 byte of control/status). The following table illustrates the Input and Output Process Image, which have a total of 3 words mapped into each image. Word alignment is applied.

Input and Output Process Image				
Offset	Byte Destination		Remark	
	High Byte	Low Byte		
0	D0	C/S	Data byte	Control/Status byte
1	D2	D1	Data bytes	
2	D4	D3		

Data Exchange Module

750-654, (and the variation /000-001)

The Data Exchange modules have a total of 4 bytes of user data in both the Input and Output Process Image. The following tables illustrate the Input and Output Process Image, which has a total of 2 words mapped into each image. Word alignment is applied.

Input and Output Process Image				
Offset	Byte Destination		Remark	
	High Byte	Low Byte		
0	D1	D0	Data bytes	
1	D3	D2		

SSI Transmitter Interface Modules

750-630, (and all variations)

The above SSI Transmitter Interface modules have a total of 4 bytes of user data in the Input Process Image, which has 2 words mapped into the image. Word alignment is applied.

Input Process Image			
Offset	Byte Destination		Remark
	High Byte	Low Byte	
0	D1	D0	Data bytes
1	D3	D2	

Incremental Encoder Interface Modules

750-631

The above Incremental Encoder Interface modules have 5 bytes of input data and 3 bytes of output data. The following tables illustrate the Input and Output Process Image, which have 4 words into each image. Word alignment is applied.

Input Process Image			
Offset	Byte Destination		Remark
	High Byte	Low Byte	
0	-	S	not used Status byte
1	D1	D0	Counter word
2	-	-	not used
3	D4	D3	Latch word

Output Process Image			
Offset	Byte Destination		Remark
	High Byte	Low Byte	
0	-	C	not used Control byte
1	D1	D0	Counter Setting word
2	-	-	not used
3	-	-	not used

750-634

The above Incremental Encoder Interface module has 5 bytes of input data (6 bytes in cycle duration measurement mode) and 3 bytes of output data. The following tables illustrate the Input and Output Process Image, which has 4 words mapped into each image. Word alignment is applied.

Input Process Image				
Offset	Byte Destination		Remark	
	High Byte	Low Byte		
0	-	S	not used	Status byte
1	D1	D0	Counter word	
2	-	(D2)* ¹⁾	not used	(Periodic time)
3	D4	D3	Latch word	

*¹⁾ If cycle duration measurement mode is enabled in the control byte, the cycle duration is given as a 24-bit value that is stored in D2 together with D3/D4.

Output Process Image				
Offset	Byte Destination		Remark	
	High Byte	Low Byte		
0	-	C	not used	Control byte
1	D1	D0	Counter Setting word	
2	-	-	not used	
3	-	-		

750-637

The above Incremental Encoder Interface Module has a total of 6 bytes of user data in both the Input and Output Process Image (4 bytes of encoder data and 2 bytes of control/status). The following table illustrates the Input and Output Process Image, which have 4 words mapped into each image. Word alignment is applied.

Input and Output Process Image				
Offset	Byte Destination		Remark	
	High Byte	Low Byte		
0	-	C0/S0	Control/Status byte of Channel 1	
1	D1	D0	Data Value of Channel 1	
2	-	C1/S1	Control/Status byte of Channel 2	
3	D3	D2	Data Value of Channel 2	

750-635, 753-635

The above Digital Pulse Interface module has a total of 4 bytes of user data in both the Input and Output Process Image (3 bytes of module data and 1 byte of control/status). The following table illustrates the Input and Output Process Image, which have 2 words mapped into each image. Word alignment is applied.

Input and Output Process Image				
Offset	Byte Destination		Remark	
	High Byte	Low Byte		
0	D0	C0/S0	Data byte	Control/Status byte
1	D2	D1	Data bytes	

RTC Module

750-640

The RTC Module module has a total of 6 bytes of user data in both the Input and Output Process Image (4 bytes of module data and 1 byte of control/status and 1 byte ID for command). The following table illustrates the Input and Output Process Image, which have 3 words mapped into each image. Word alignment is applied.

Input and Output Process Image				
Offset	Byte Destination		Remark	
	High Byte	Low Byte		
0	ID	C/S	Command byte	Control/Status byte
1	D1	D0	Data bytes	
2	D3	D2		

DALI/DSI Master Module

750-641

The DALI/DSI Master module has a total of 6 bytes of user data in both the Input and Output Process Image (5 bytes of module data and 1 byte of control/status). The following tables illustrate the Input and Output Process Image, which have 3 words mapped into each image. Word alignment is applied.

Input Process Image				
Offset	Byte Destination		Remark	
	High Byte	Low Byte		
0	D0	S	DALI Response	Status byte
1	D2	D1	Message 3	DALI Address
3	D4	D3	Message 1	Message 2

Output Process Image				
Offset	Byte Destination		Remark	
	High Byte	Low Byte		
0	D0	C	DALI command, DSI dimming value	Control byte
1	D2	D1	Parameter 2	DALI Address
3	D4	D3	Command- Extension	Parameter 1

EnOcean Radio Receiver

750-642

The EnOcean radio receiver has a total of 4 bytes of user data in both the Input and Output Process Image (3 bytes of module data and 1 byte of control/status). The following tables illustrate the Input and Output Process Image, which have 2 words mapped into each image. Word alignment is applied.

Input Process Image				
Offset	Byte Destination		Remark	
	High Byte	Low Byte		
0	D0	S	Data byte	Status byte
1	D2	D1	Data bytes	

Output Process Image				
Offset	Byte Destination		Remark	
	High Byte	Low Byte		
0	-	C	not used	Control byte
1	-	-	not used	

MP Bus Master Module

750-643

The MP Bus Master Module has a total of 8 bytes of user data in both the Input and Output Process Image (6 bytes of module data and 2 bytes of control/status). The following table illustrates the Input and Output Process Image, which have 4 words mapped into each image. Word alignment is applied.

Input and Output Process Image				
Offset	Byte Destination		Remark	
	High Byte	Low Byte		
0	C1/S1	C0/S0	extended Control/Status byte	Control/Status byte
1	D1	D0	Data bytes	
2	D3	D2		
3	D5	D4		

Vibration Velocity/Bearing Condition Monitoring VIB I/O

750-645

The Vibration Velocity/Bearing Condition Monitoring VIB I/O has a total of 12 bytes of user data in both the Input and Output Process Image (8 bytes of module data and 4 bytes of control/status). The following table illustrates the Input and Output Process Image, which have 8 words mapped into each image. Word alignment is applied.

Input and Output Process Image				
Offset	byte Destination		Remark	
	High Byte	Low Byte		
0	-	C0/S0	Not used	Control/Status byte (log. Channel 1, Sensor input 1)
1	D1	D0	Data bytes (log. Channel 1, Sensor input 1)	
2	-	C1/S1	Not used	Control/Status byte (log. Channel 2 Sensor input 2)
3	D3	D2	Data bytes (log. Channel 2 Sensor input 2)	
4	-	C2/S2	Not used	Control/Status byte (log. Channel 3 Sensor input 1)
5	D5	D4	Data bytes (log. Channel 3 Sensor input 1)	
6	-	C3/S3	Not used	Control/Status byte (log. Channel 4 Sensor input 2)
7	D7	D6	Data bytes (log. Channel 4 Sensor input 2)	

AS-interface Master Module

750-655

The length of the process image of the AS-interface master module can be set to fixed sizes of 12, 20, 24, 32, 40 or 48 bytes.

It consists of a control or status byte, a mailbox with a size of 0, 6, 10, 12 or 18 bytes and the AS-interface process data, which can range from 0 to 32 bytes.

The AS-interface master module has a total of 6 to maximally 24 words data in both the Input and Output Process Image. Word alignment is applied.

The first Input and output word, which is assigned to an AS-interface master module, contains the status / control byte and one empty byte. Subsequently the mailbox data are mapped, when the mailbox is permanently superimposed (Mode 1).

In the operating mode with suppressable mailbox (Mode 2), the mailbox and the cyclical process data are mapped next. The following words contain the remaining process data.

Input and Output Process Image				
Offset	Byte Destination		Remark	
	High Byte	Low Byte		
0	-	C0/S0	not used	Control/Status byte
1	D1	D0	Mailbox (0, 3, 5, 6 or 9 words) / Process data (0-16 words)	
2	D3	D2		
3	D5	D4		
...		
max. 23	D45	D44		

5.2.6 System Modules

System Modules with Diagnostics

750-610, -611

The 750-610 and 750-611 Supply Modules provide 2 bits of diagnostics in the Input Process Image for monitoring of the internal power supply.

Input Process Image							
Bit 7	Bit 6	Bit 5	Bit 4	Bit 3	Bit 2	Bit 1	Bit 0
						Diagnostic bit S 2 Fuse	Diagnostic bit S 1 Voltage

Binary Space Module

750-622

The Binary Space Modules 750-622 behave alternatively like 2 channel digital input modules or output modules and seize depending upon the selected settings 1, 2, 3 or 4 bits per channel. According to this, 2, 4, 6 or 8 bits are occupied then either in the process input or the process output image.

Input or Output Process Image							
Bit 7	Bit 6	Bit 5	Bit 4	Bit 3	Bit 2	Bit 1	Bit 0
(Data bit DI 8)	(Data bit DI 7)	(Data bit DI 6)	(Data bit DI 5)	(Data bit DI 4)	(Data bit DI 3)	Data bit DI 2	Data bit DI 1

6 Application Examples

6.1 Test of MODBUS protocol and fieldbus nodes

You require a MODBUS master to test the function of your fieldbus node. For this purpose, various manufacturers offer a range of PC applications that you can, in part, download from the Internet as free of charge demo versions. One of the programs which is particularly suitable to test your ETHERNET TCP/IP fieldbus node, is for instance **ModScan** from **Win-Tech**.



More information

A free of charge demo version from ModScan32 and further utilities from Win-Tech can be found in the Internet under:

<http://www.win-tech.com/html/demos.htm>

ModScan32 is a Windows application that works as a MODBUS master. This program allows you to access the data points of your connected ETHERNET TCP/IP fieldbus node and to proceed with the desired changes.



More information

For a description example relating to the software operation, please refer to:

<http://www.win-tech.com/html/modscan32.htm>

6.2 Visualization and control using SCADA software

This chapter is intended to give insight into how the WAGO ETHERNET fieldbus coupler/controller can be used for process visualization and control using standard user software.

There is a wide range of process visualization programs, called SCADA Software, from various manufacturers.



More information

For a selection of SCADA products, look under i.e.:

<http://www.abpubs.demon.co.uk/scadasites.htm>

SCADA is the abbreviation for Supervisory Control and Data Acquisition.

It is a user-orientated tool used as a production information system in the areas of automation technology, process control and production monitoring.

The use of SCADA systems includes the areas of visualization and monitoring, data access, trend recording, event and alarm processing, process analysis and targeted intervention in a process (control).

The WAGO ETHERNET fieldbus node provides the required process input and output values.

**Attention!**

When choosing suitable SCADA software, ensure that it provides a MODBUS device driver and supports the MODBUS/TCP functions in the coupler.

Visualization programs with MODBUS device drivers are available from i.e. Wonderware, National Instruments, Think&Do or KEPware Inc., some of which are available on the Internet as demo versions.

The operation of these programs is very specific. However, a few essential steps are described to illustrate the way an application can be developed using a WAGO ETHERNET fieldbus node and SCADA software in principle.

- The initial prerequisite is that the MODBUS ETHERNET driver has been loaded and MODBUS ETHERNET has been selected.
- Subsequently, the user is requested to enter the IP address for addressing the fieldbus node.
At this point, some programs allow the user to give the node an alias name, i.e. to call the node "Measuring data". The node can then be addressed with this name.
- Then, a graphic object can be created, such as a switch (digital) or a potentiometer (analog).
This object is displayed on the work area and is linked to the desired data point on the node.
- This link is created by entering the node address (IP address or alias name) of the desired MODBUS function codes (register/bit read/write) and the MODBUS address of the selected channel.
Entry is, of course, program specific.
Depending on the user software the MODBUS addressing of a bus module can be represented with 3 or, as in the following example, with 5 digits.

Example of the MODBUS function code

In the case of SCADA Software Lookout from National Instruments the MODBUS function codes are used with a 6 bit coding, whereby the first bit represents the function code:

Input code:	MODBUS function code	
0	FC1 ⇔ read coils	Reading of several input bits
1	FC2 ⇔ read input discretes	Reading of several input bits
3	FC3 ⇔ read multiple registers	Reading of several input registers
4	FC4 ⇔ read input registers	Reading of an individual input register

The following five digits specify the channel number of the consecutively numbered digital or analog input and/or output channels.

Examples:

- Read the first digital input: i.e. 0 0000 1
- Read the second analog input: i.e. 3 0000 2

Application example:

Thus, the digital input channel 2 of the above node "Measuring data" can be read out with the input: "Measuring data. 0 0000 2".

Example:

SCADA software with Modbus Driver

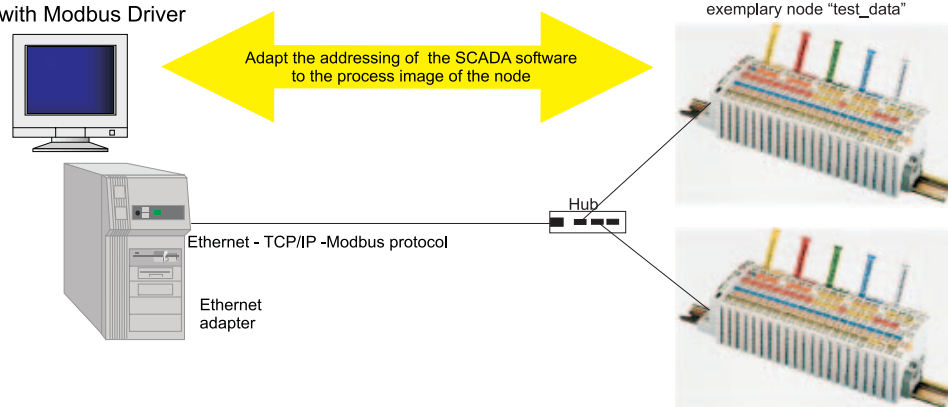

Fig. 6-1: Example of user software

G012913e



More information

Please refer to the respective SCADA product manual for a detailed description of the particular software operation.

7 Use in Hazardous Environments

7.1 Foreword

Today's development shows that many chemical and petrochemical companies have production plants, production, and process automation machines in operation which use gas-air, vapor-air and dust-air mixtures which can be explosive. For this reason, the electrical components used in such plants and systems must not pose a risk of explosion resulting in injury to persons or damage to property. This is backed by law, directives or regulations on a national and international scale. WAGO-I/O-SYSTEM 750 (electrical components) is designed for use in zone 2 explosive environments. The following basic explosion protection related terms have been defined.

7.2 Protective measures

Primarily, explosion protection describes how to prevent the formation of an explosive atmosphere. For instance by avoiding the use of combustible liquids, reducing the concentration levels, ventilation measures, to name but a few. But there are a large number of applications, which do not allow the implementation of primary protection measures. In such cases, the secondary explosion protection comes into play. Following is a detailed description of such secondary measures.

7.3 Classification meeting CENELEC and IEC

The specifications outlined here are valid for use in Europe and are based on the following standards: EN50... of CENELEC (European Committee for Electrotechnical Standardization). On an international scale, these are reflected by the IEC 60079-... standards of the IEC (International Electrotechnical Commission).

7.3.1 Divisions

Explosive environments are areas in which the atmosphere can potentially become explosive. The term explosive means a special mixture of ignitable substances existing in the form of air-borne gases, fumes, mist or dust under atmospheric conditions which, when heated beyond a tolerable temperature or subjected to an electric arc or sparks, can produce explosions. Explosive zones have been created to describe the concentrations level of an explosive atmosphere. This division, based on the probability of an explosion occurring, is of great importance both for technical safety and feasibility reasons. Knowing that the demands placed on electrical components permanently employed in an explosive environment have to be much more stringent than those placed on electrical components that are only rarely and, if at all, for short periods, subject to a dangerous explosive environment.

Explosive areas resulting from gases, fumes or mist:

Zone 0 areas are subject to an explosive atmosphere (> 1000 h /year) continuously or for extended periods.

Zone 1 areas can expect the occasional occurrence of an explosive atmosphere (> 10 h ≤ 1000 h /year).

Zone 2 areas can expect the rare or short-term occurrence of an explosive atmosphere (> 0 h ≤ 10 h /year).

Explosive areas subject to air-borne dust:

Zone 20 areas are subject to an explosive atmosphere (> 1000 h /year) continuously or for extended periods.

Zone 21 areas can expect the occasional occurrence of an explosive atmosphere (> 10 h ≤ 1000 h /year).

Zone 22 areas can expect the rare or short-term occurrence of an explosive atmosphere (> 0 h ≤ 10 h /year).

7.3.2 Explosion protection group

In addition, the electrical components for explosive areas are subdivided into two groups:

Group I: Group I includes electrical components for use in fire-damp endangered mine structures.

Group II: Group II includes electrical components for use in all other explosive environments. This group is further subdivided by pertinent combustible gases in the environment. Subdivision IIA, IIB and IIC takes into account that different materials/substances/gases have various ignition energy characteristic values. For this reason the three sub-groups are assigned representative types of gases:

IIA – Propane
IIB – Ethylene
IIC – Hydrogen

Minimal ignition energy of representative types of gases				
Explosion group	I	IIA	IIB	IIC
Gases	Methane	Propane	Ethylene	Hydrogen
Ignition energy (μJ)	280	250	82	16

Hydrogen being commonly encountered in chemical plants, frequently the explosion group IIC is requested for maximum safety.

7.3.3 Unit categories

Moreover, the areas of use (zones) and the conditions of use (explosion groups) are subdivided into categories for the electrical operating means:

Unit categories	Explosion group	Area of use
M1	I	Fire-damp protection
M2	I	Fire-damp protection
1G	II	Zone 0 Explosive environment by gas, fumes or mist
2G	II	Zone 1 Explosive environment by gas, fumes or mist
3G	II	Zone 2 Explosive environment by gas, fumes or mist
1D	II	Zone 20 Explosive environment by dust
2D	II	Zone 21 Explosive environment by dust
3D	II	Zone 22 Explosive environment by dust

7.3.4 Temperature classes

The maximum surface temperature for electrical components of explosion protection group I is 150 °C (danger due to coal dust deposits) or 450 °C (if there is no danger of coal dust deposit).

In line with the maximum surface temperature for all ignition protection types, the electrical components are subdivided into temperature classes, as far as electrical components of explosion protection group II are concerned. Here the temperatures refer to a surrounding temperature of 40 °C for operation and testing of the electrical components. The lowest ignition temperature of the existing explosive atmosphere must be higher than the maximum surface temperature.

Temperature classes	Maximum surface temperature	Ignition temperature of the combustible materials
T1	450 °C	> 450 °C
T2	300 °C	> 300 °C to 450 °C
T3	200 °C	> 200 °C to 300 °C
T4	135 °C	> 135 °C to 200 °C
T5	100 °C	>100 °C to 135 °C
T6	85°C	> 85 °C to 100 °C

The following table represents the division and attributes of the materials to the temperature classes and material groups in percent:

Temperature classes						
T1	T2	T3	T4	T5	T6	Total*
26.6 %	42.8 %	25.5 %				
94.9 %			4.9 %	0 %	0.2 %	432
Explosion group						
IIA	IIB	IIC				Total*
85.2 %	13.8 %	1.0 %				501

* Number of classified materials

7.3.5 Types of ignition protection

Ignition protection defines the special measures to be taken for electrical components in order to prevent the ignition of surrounding explosive atmospheres. For this reason a differentiation is made between the following types of ignition protection:

Identifi- cation	CENELEC standard	IEC standard	Explanation	Application
EEx o	EN 50 015	IEC 79-6	Oil encapsulation	Zone 1 + 2
EEx p	EN 50 016	IEC 79-2	Overpressure encapsulation	Zone 1 + 2
EEx q	EN 50 017	IEC 79-5	Sand encapsulation	Zone 1 + 2
EEx d	EN 50 018	IEC 79-1	Pressure resistant encapsulation	Zone 1 + 2
EEx e	EN 50 019	IEC 79-7	Increased safety	Zone 1 + 2
EEx m	EN 50 028	IEC 79-18	Cast encapsulation	Zone 1 + 2
EEx i	EN 50 020 (unit) EN 50 039 (system)	IEC 79-11	Intrinsic safety	Zone 0 + 1 + 2
EEx n	EN 50 021	IEC 79-15	Electrical components for zone 2 (see below)	Zone 2

Ignition protection “n” describes exclusively the use of explosion protected electrical components in zone 2. This zone encompasses areas where explosive atmospheres can only be expected to occur rarely or short-term. It represents the transition between the area of zone 1, which requires an explosion protection and safe area in which for instance welding is allowed at any time.

Regulations covering these electrical components are being prepared on a world-wide scale. The standard EN 50 021 allows electrical component manufacturers to obtain certificates from the corresponding authorities for instance KEMA in the Netherlands or the PTB in Germany, certifying that the tested components meet the above mentioned standards draft.

Type “n” ignition protection additionally requires electrical components to be marked with the following extended identification:

A – non spark generating (function modules without relay /without switches)

AC – spark generating, contacts protected by seals (function modules with relays / without switches)

L – limited energy (function modules with switch)



Further information

For more detailed information please refer to the national and/or international standards, directives and regulations!

7.4 Classifications meeting the NEC 500

The following classifications according to NEC 500 (National Electric Code) are valid for North America.

7.4.1 Divisions

The "Divisions" describe the degree of probability of whatever type of dangerous situation occurring. Here the following assignments apply:

Explosion endangered areas due to combustible gases, fumes, mist and dust:	
Division 1	Encompasses areas in which explosive atmospheres are to be expected occasionally ($> 10 \text{ h} \leq 1000 \text{ h /year}$) as well as continuously and long-term ($> 1000 \text{ h /year}$).
Division 2	Encompasses areas in which explosive atmospheres can be expected rarely and short-term ($> 0 \text{ h} \leq 10 \text{ h /year}$).

7.4.2 Explosion protection groups

Electrical components for explosion endangered areas are subdivided in three danger categories:

Class I (gases and fumes):	Group A (Acetylene) Group B (Hydrogen) Group C (Ethylene) Group D (Methane)
Class II (dust):	Group E (Metal dust) Group F (Coal dust) Group G (Flour, starch and cereal dust)
Class III (fibers):	No sub-groups

7.4.3 Temperature classes

Electrical components for explosive areas are differentiated by temperature classes:

Temperature classes	Maximum surface temperature	Ignition temperature of the combustible materials
T1	450 °C	> 450 °C
T2	300 °C	> 300 °C to 450 °C
T2A	280 °C	> 280 °C to 300 °C
T2B	260 °C	> 260 °C to 280 °C
T2C	230 °C	>230 °C to 260 °C
T2D	215 °C	>215 °C to 230 °C
T3	200 °C	>200 °C to 215 °C
T3A	180 °C	>180 °C to 200 °C
T3B	165 °C	>165 °C to 180 °C
T3C	160 °C	>160 °C to 165 °C
T4	135 °C	>135 °C to 160 °C
T4A	120 °C	>120 °C to 135 °C
T5	100 °C	>100 °C to 120 °C
T6	85 °C	> 85 °C to 100 °C

7.5 Identification

7.5.1 For Europe

According to CENELEC and IEC

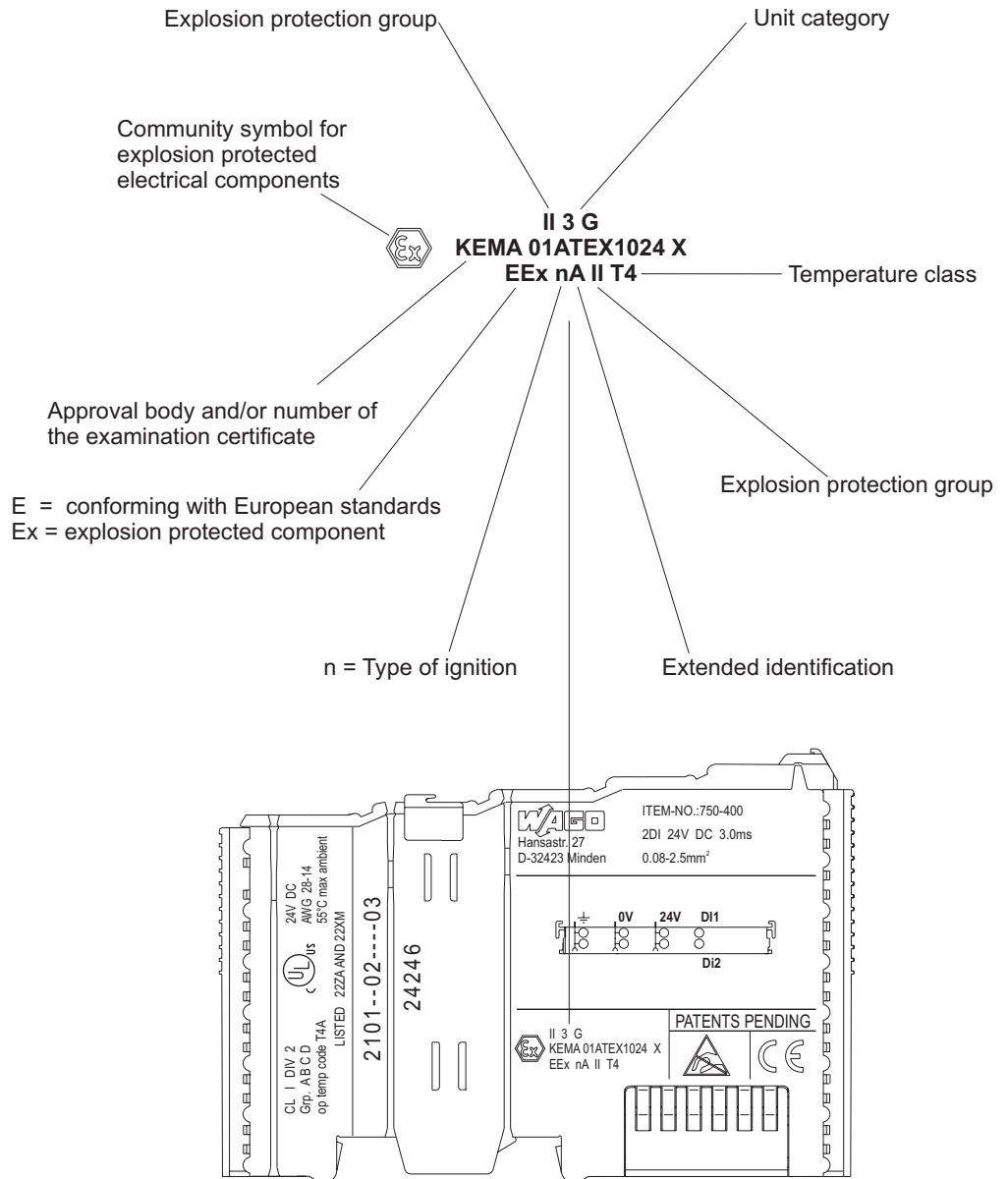

Fig. 7.5.1-1: Example for lateral labeling of bus modules
(750-400, 2 channel digital input module 24 V DC)

g01xx03e

7.5.2 For America

According to NEC 500

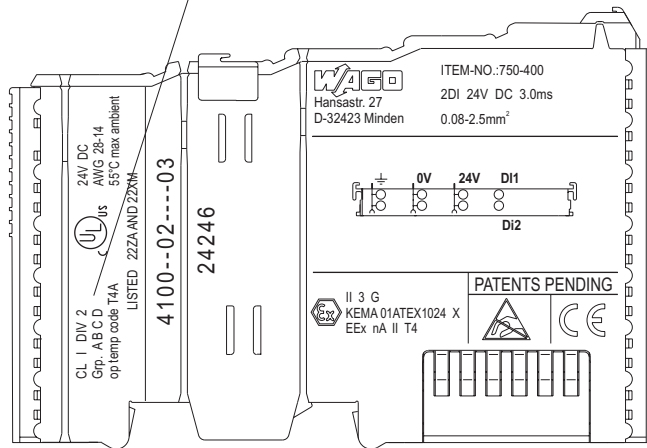
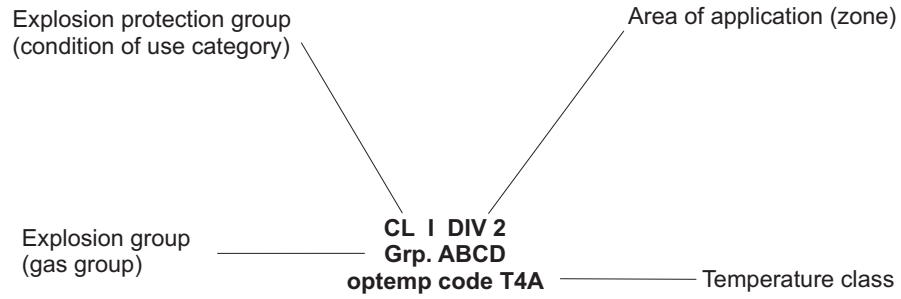

Fig. 7.5.2-1: Example for lateral labeling of bus modules
(750-400, 2 channel digital input module 24 V DC)

g01xx04e

7.6 Installation regulations

In the **Federal Republic of Germany**, various national regulations for the installation in explosive areas must be taken into consideration. The basis being the ElexV complemented by the installation regulation DIN VDE 0165/2.91. The following are excerpts from additional VDE regulations:

DIN VDE 0100	Installation in power plants with rated voltages up to 1000 V
DIN VDE 0101	Installation in power plants with rated voltages above 1 kV
DIN VDE 0800	Installation and operation in telecommunication plants including information processing equipment
DIN VDE 0185	lightning protection systems

The **USA** and **Canada** have their own regulations. The following are excerpts from these regulations:

NFPA 70	National Electrical Code Art. 500 Hazardous Locations
ANSI/ISA-RP 12.6-1987	Recommended Practice
C22.1	Canadian Electrical Code



Danger

When using the WAGO-I/O SYSTEM 750 (electrical operation) with Ex approval, the following points are mandatory:

The fieldbus independent I/O System Modules Type 750-xxx are to be installed in enclosures that provide for the degree of ingress protection of at least IP54.

For use in the presence of combustible dust, the above mentioned modules are to be installed in enclosures that provide for the degree of ingress protection of at least IP64.

The fieldbus independent I/O system may only be installed in hazardous areas (Europe: Group II, Zone 2 or America: Class I, Division 2, Group A, B, C, D) or in non-hazardous areas!

Installation, connection, addition, removal or replacement of modules, fieldbus connectors or fuses may only take place when the system supply and the field supply are switched off, or when the area is known to be non-hazardous.

Ensure that only approved modules of the electrical operating type will be used. The Substitution or Replacement of modules can jeopardize the suitability of the system in hazardous environments!

Operation of intrinsically safe EEx i modules with direct connection to sensors/actuators in hazardous areas of Zone 0 + 1 and Division 1 type requires the use of a 24 V DC Power Supply EEx i module!

DIP switches and potentiometers are only to be adjusted when the area is known to be non-hazardous.



Further Information

Proof of certification is available on request. Also take note of the information given on the module technical information sheet.

8 Glossary

B**Baseband**

Systems which operate without carrier frequencies, i.e. with unmodulated signals. Therefore, they only offer one channel which has to be logically tailored to the various requirements. Opposite: Wideband.

Bit

Smallest information unit. Its value can either be 1 or 0.

Bit rate

Number of bits transmitted within a time unit.

BNC

Bayonet Navy Connector. Socket for coaxial cable.

BootP

the bootstrap protocol is a protocol which specifies how system and network information is to be transmitted from a *server* to work stations.

Bridge

Connects two separate networks.

Broadcast

A message that is sent to all station connected to the network.

Bus

A structure used to transmit data. There are two types, serial and parallel. A serial bus transmits data bit by bit, whereas a parallel bus transmits many bits at one time.

Byte

Binary Yoked Transfer Element. A byte generally contains 8 bits.

C**Client**

A system that requests the services of another. With the aid of the service request, the client can access objects (data) on the *server*. The service is provided by the server.

Coaxial cable

This cable contains a single wire and a radial shield to transmit information.

CSMA/CD

Carrier Sense Multiple Access with Collision Detection. When a collision is detected, all subscribers back off. After waiting a random delay time, the subscribers attempt to re-transmit the data.

D**Data bus**

see *Bus*.

Deterministic ETHERNET

The ETHERNET data is transferred at a defined time constant. The ETHERNET network can be defined and calculated. A *Switched ETHERNET* architecture makes this possible.

Driver

Software code which communicates with a hardware device. This communication is normally performed by internal device registers.

E**ETHERNET**

Specifies a Local Area Network (LAN), which was developed by Xerox, Intel and DEC in the 70's. The bus access process takes place according to the *CSMA/CD* method.

ETHERNET Standard

In 1983 ETHERNET was standardized by *IEEE 802.3* 10Base-5. ISO took over the standardization in the ISO Standard 8802/3. The essential differences between ETHERNET and the IEEE standard are to be found in the frame architecture and treatment of pad characters.

F

Fieldbus

System for serial information transmission between devices of automation technology in the process-related field area.

Firewall

Collective term for solutions which protect *LANs* connection to the *Internet* from unauthorized access. They are also able to control and regulate the traffic from the LAN into the Internet. The crucial part of firewalls are static *routers* which have an access control list used to decide which data packets can pass from which *subscriber*.

Frame

Unit of data transferred at the Data-Link layer. It contains the header and addressing information.

FTP

(File Transfer Protocol) A standard application for *TCP/IP* which allows users on one machine to transfer files to/from another.

Function

Module that always returns the same result (as a function value), prerequisite being identical input values; it has no local variables that store values beyond an invoke.

Function block

Module that delivers one or more values when being executed. They can be stored as local variables („Memory“).

G**Gateway**

Device for connecting two different networks. It converts the different protocols.

H**Hardware**

Electronic, electrical and mechanic components of a module/subassembly.

Header

A portion of the data packet, containing, among others, the address information of the receiver.

Host computer / Subscriber

Originally used to describe a central mainframe computer accessed from other systems. The services provided by the subscriber can be called up by means of local and remote request. Today, this term is also used to refer to simple computers which provide particular central *Services* (i.e. UNIX-Subscribers on the *Internet*).

HTML

Abbreviation of hypertext markup language

HTML is the description language for documents on the *World Wide Web*. It contains language elements for the design of hypertext documents.

HTTP

(Hyper Text Transfer Protocol) *client server TCP/IP* protocol which is used on the *Internet* or *Intranets* for exchanging HTML documents. It normally uses *port 80*.

Hub

A device which allows communication between several network users via *twisted pair* cable.

Similar to a *repeater*, but with many outputs, a hub is used to form a star topology.

Hypertext

Document format used by *HTTP*. Hypertext documents are text files which allow links to other text documents via particularly highlighted keywords.

I

IAONA Europe

IAONA Europe (Industrial Automation Open Networking Alliance) is an organization for industrial network technology with the objective to establish ETHERNET in automation technology.

Further information on this subject is available on the Internet under:

www.iaona-eu.com.

ICMP-Protocol

TA protocol for the transmission of status information and error messages of the *IP*, *TCP* and *UDP* protocols between IP network nodes. ICMP offers, among others, the possibility of an echo (ping) request to determine whether a destination is available and is responding.

IEC 61131-3

International standard published in 1993 for morn systems with PLC functionality. Based on a structured software model, it defines a number of high performance programming languages that can be used for various automation tasks.

IEEE

Institute of Electrical and Electronic Engineers.

IEEE 802.3

IEEE 802.3 is a IEEE standard. ETHERNET only supports the yellow cable as a medium. IEEE 802.3 also supports *S-UTP* and wideband coaxial cable. The segment lengths range from 500 m for yellow cable, 100 m for TP and 1800 m for wideband coaxial cable. A star or a bus topology is possible. ETHERNET (IEEE 802.3) uses *CSMA/CD* as a channel access method.

Intel format

Set configuration of the fieldbus coupler / controller to establish the process image. In the coupler/controller memory, the module data is aligned in different ways, depending on the set configuration (Intel/Motorola-Format, *word-alignment*,...). The format determines whether or not high and low bytes are changed over. They are not changed over with the Intel format.

Internet

A collection of networks interconnected to each other throughout the world. Its most well known area is the *World Wide Web*.

Intranet

A network concept with private network connections over which data can be exchanged within a company.

IP

Internet Protocol. The connectionless network layer, which relies on upper protocols to provide reliability.

ISA

Industry Standard Architecture. Offers a standard interface for the data exchange between CPU and periphery.

ISO/OSI- Reference Model

Reference model of the ISO/OSI for networks with the objective of creating open communication. It defines the interface standards of the respective software and hardware requirements between computer manufacturers. The model treats communication removed from specific implementations, using seven layers.

L**LAN**

Local Area Network

Library

Compilation of modules available to the programmer in the programming tool **WAGO-I/O-PRO 32** for the creation of a control program according to IEC 61131-3.

M**Mail Server**

Internet E-mails are transported and stored temporarily by so-called Mail servers. The personal post can be downloaded by such a Mail server or be sent in reverse to the far dispatch to these. With the SMTP protocol E-mails can be dispatched.

Manchester encoding

In this encoding system, a 1 is encoded as a transition from *low* to *high* and a 0 as a transition from *high* to *low*.

Modules

Functions, function blocks and programs are modules.

Each module has a declaration part and a body, the latter being written in one of the IEC programming languages IL (instruction list), ST (structured text), SFC (sequential flow), FBD (function block diagram) or LD (ladder diagram).

MS-DOS

Operating system, which allows all applications direct access to the hardware.

O

Open MODBUS/TCP Specification

Specification which establishes the specific structure of a MODBUS/TCP data packet. This is dependant upon the selected function code.

Operating system

Software which links the application programs to the hardware.

P

Ping command

When a ping command (ping <IP address>) is entered, the ping program *ICMP* generates echo *request* packets. It is used to test whether a node is available.

Port number

The port number, together with the IP address, forms an unambiguous connection point between two processes (applications).

Predictable ETHERNET

The delay time of a message on an ETHERNET network can be predicted. The measures which have been taken in predictable ETHERNET make it virtually possible to realize realtime requirements.

Proxy gateway

A proxy gateway (or proxy *server*, too) allows systems which do not have direct access to the *Internet*, indirect access to the network. These can be systems which are excluded from direct access by a *firewall* for security reasons.

A proxy can filter out individual data packets between the Internet and a local network to increase security. Proxies are also used to limit access to particular servers.

In addition, proxy gateways can also have a cache function, in which case they check whether the respective *URL* address is already available locally and return it immediately, if necessary. This saves time and costs when there are multiple accesses. If the URL is not in the cache, the proxy forwards the *request* as normal.

The user should not notice the proxy *gateway* apart from the single configuration in the *web browser*. Most web browsers can be configured so that they use different or no proxy gateways per access method (*FTP*, *HTTP*).

R

Repeater

Repeaters are physical amplifiers without their own processing function. They refresh data without detecting damaged data and forward all signals. Repeaters are used for longer transmission distances or when the maximum number of nodes of 64 devices per *twisted pair* segment is exceeded. A request from a client to server is a provision to act on a service or function call.

Request

A service request from a client which requests the provision of a service from a server.

Response

The server's reply to a client's request.

RFC specifications

Specifications, suggestions, ideas and guidelines regarding the *Internet* are published in the form of RFCs (Request For Comments).

RJ45 connector

Also referred to as a Western connector. This connector allows the connection of two network controllers via *twisted pair* cables.

Router

Connects neighboring *subnets*, the router operating with addresses and protocols of the third *ISO/OSI* layer. As this layer is hardware independent, the routers allow transition to another transmission medium.

To transmit a message the router evaluates the logical address (source and destination address) and finds the best path if there are several possibilities. Routers can be operated as *repeaters* or *bridges*.

Routing

Method of selecting the best path over which to send data to a distant network.

S

SCADA

Abbreviation for Supervisory Control and Data Acquisition. SCADA software is a program for the control and visualization of processes.

Segment

Typically, a network is divided up into different physical network segments by way of *routers* or *repeaters*.

Server

Device providing services within a client/server system. The service is requested by the *Client*.

Service

An operation targeted at an object (read, write).

SMTP

Short form for „Simple Mail Transfer Protocol“. Standard protocol, with which E-mails are sent away in the internet.

SOAP

Short form for “Simple Object Access Protocol“. XML is a standard for Meta data, the access on the XML objects takes place via SOAP. The standard defines, how transactions via internet and XML can be done and how dynamic Web services over distributed networks can be used.

Socket

Is a software interface introduced with BSD-UNIX for inter-process communication. Sockets are also possible in the network via TCP/IP. As from Windows 3.11, they are also available in Microsoft operating systems.

STP

With the STP cable (Shielded twisted pair) it acts around a symmetrical cable with in pairs stranded and protected veins. The classical STP cable is a multi-core cable, whose stranded conductors are isolated. The conductors of the STP cable are individually protected. It has no total screen.

S-STP

Beside the STP cables there is cable, which has total shielding from foil or network shielding additionally to the single shielding of the conductors still another. These cables are called S/STP cables: Screened/Shielded twisted pair.

Structured cabling

This specifies the maximum permissible cable lengths (EIA/TIA 568, IS 11801) and gives recommendations for the different types topology for ground area, building and floor cabling.

Subnet

A portion of a network that shares the same network address as the other portions. These subnets are distinguished through the subnet mask.

Subnet mask

The subnet mask can be used to manipulate the address areas in the IP address room with reference to the number of *subnets* and *subscribers*. A standard subnet mask is, for example, 255.255.255.0.

S-UTP

Screened unshielded *twisted pair* cable which only has one external shield. However, the twisted pair cables are not shielded from each other.

Switch

Switches are comparable to *bridges*, but with several outputs. Each output uses the full ETHERNET bandwidth. A switch switches a virtual connection between an input port and an output port for data transmission. Switches learn which nodes are connected and filter the information transmitted over the network accordingly. Switches are intelligent devices that learn the node connections and can transfer data at the switch and not have to send it back to the main server.

Switched ETHERNET

The segments of this type of ETHERNET are connected by *switches*. There are many applications for switching technologies. ETHERNET switching is becoming increasingly popular in local networks as it allows the realization of a *deterministic ETHERNET*.

T

TCP

Transport Control Protocol.

TCP/IP Protocol Stack

Network protocols which allow communication between different networks and technologies.

Telnet

The Telnet protocol fulfils the function of a virtual terminal. It allows remote access from the user's computer to other computer systems on the network.

Twisted Pair

Twisted pair cables (abbreviated to TP).

U**UDP protocol**

The user datagram protocol is a transport protocol (layer 4) of the *ISO/OSI-reference model* which supports data exchange between computers without a connection. UDP runs directly on top of the underlying *IP* protocol.

URL

Abbreviation for uniform resource locator.

Address form for *Internet* files which are mostly applied within the World Wide Web (*WWW*). The URL format makes the unambiguous designation of all documents on the Internet possible by describing the address of a document or object which can be read by a *web browser*. URL includes the transmission type (*http*, *ftp*, *news* etc.), the computer which contains the information and the path on the computer. URL has the following format: Document type//Computer name/List of contents/File name.

UTP

The UTP cable is a symmetrical, not-protected cable with twisted colored wires in pairs. This type of cable, which there is in execution two-in pairs and four-in pairs, is the dominating type of cable in the floor wiring and the terminal wiring.

W**WAGO-I/O-PRO CAA**

Uniform programming environment, programming tool from WAGO Kontakttechnik GmbH for the creation of a control program according to IEC 61131-3 for all programmable fieldbus controllers. Allows testing, debugging and the start-up of a program.

Web browser

Program for reading *hypertext*. The browser allows the various documents to be viewed in hypertext and navigation between documents.

Wide band

Transmission technology which operates with a high bandwidth, thereby permitting high transmission rates. This allows several devices to transmit simultaneously.

Opposite: Baseband.

Word-alignment

Set configuration of the fieldbus coupler/controller for the creation of a process image. Word-alignment is used to establish the process image word-by-word (2 bytes).

World Wide Web

HTTP server on the Internet.

9 Literature List



Manual TCP/IP-ETHERNET for Beginners

Wiesemann & Theis GmbH

1st edition, 11/1999

http://www.WuT.de/us_printmed.html

Local Area Networks - An introduction to the technology

John E. McNamara,

Digital Press, 1985

ISBN 0-932376-79-7 Digital Press Teil Nummer EY-00051-DP

Network Troubleshooting Guide von Digital Equipment Corporation,

August 1990,

Digital Press Teil Nummer EK-339AB-GD-002

Zu RFC:

Request for Comments

<http://members.xoom.com/spielchen2k/archiv/public/exploits/rfcs/rfcs/>

10 Index

- 10Base-T 53, 74
- Access
 - Simultaneous 97
- Address
 - Ethernet 44, 84
 - Hardware 84
 - IP 85
 - TCP- 90
- BootP 91
- Bridge 78, 167, 177
- Bus access procedure 84
- Cable
 - Category 5 74
 - Crossover 74
 - Impedance 74
 - length 69
 - Parallel 74
- carrier rail 16, 19
- Configuration** 55
 - function** 112, 120
- Constant Register** 123
- contacts
 - data- 20
 - power- 27
- Coupler modules 78
- Crossover cable 53, 55, 74
- CSMA/CD 84
- data contacts 20
- Data packet 84
 - Ethernet 84
 - IP** 88
 - Modbus 97
 - TCP 90
 - TCP/IP** 90
- Data security 79
- Delay time 79
- Diagnosis 58
- Diagnosis information 71
- Diagnostic**
 - function** 120
- Electrical isolation 42
- Error
 - diagnosis 58
 - During run-up 53
 - Message 57
- Ethernet 71
 - Address 84
 - Buscoupler 154
 - Industry 79
 - Network 54, 78
 - Network architecture 72
 - Predictable 80
 - Shared 79
 - Standard 73, 84
 - Switched 80
- Ethernet standard 73, 75
- Exception 100, 101, 102, 103, 104, 105, 106, 107, 108, 109, 110, 111
- Fieldbus failure 68, 115
- Fieldbus node
 - Architecture 72
- Firewall 79
- Firmware Information** 122
- function code**
 - FC6** 106
- function code 97, 116, 155
 - Application example** 156
 - FC1** 101
 - FC11** 108
 - FC15** 109
 - FC16** 110
 - FC2** 102
 - FC23** 110
 - FC3** 103
 - FC4** 104
 - FC5** 105
 - FC7** 107
 - Gateway 54, 55, 58, 78, 88, 170, 174
 - HTML pages 53, 58, 92
 - HTTP 92
 - hub 72, 74, 78, 79
 - Hub 75, 170
 - I/O Modules 126
 - Intel format 52
 - internal bus 41
 - Internal bus fault 68
 - Internal Variables 113
 - Internet 72, 79, 87, 92
 - Intranet 79
 - IP address 53, 54, 57, 59, 85, 86, 88, 91, 155
 - Key data 86
 - LED
 - Flash code 53
 - Green 53
 - Red 53
 - Light diodes** 43
 - locking disc 18
 - MAC-ID 44, 84
 - Modbus Register Mapping 112
 - Modbus/TCP 97
 - function code 97, 155
 - Specification 173
 - Network card* 54, 72, 74, 88
 - Network class 85
 - node
 - max. number 86
 - Nodes
 - Function tests of 53
 - Ping command** 57, 173
 - Port number 90, 174
 - Port number 502** 97
 - Port number 80 92
 - Power contacts 21, 27
 - not carried out 28
 - Predictable Ethernet 80
 - Process
 - Visualisation 72
 - Process data 71
 - Process image 97
 - Protocols 71
 - BootP 86
 - Proxy 59, 174
 - Realtime behaviour 79
 - Realtime requirements** 80
 - Repeater 72, 78, 174
 - Request 100, 101, 102, 103, 104, 105, 106, 107, 108, 109, 110, 174
 - Request error 100
 - Reset
 - Hardware 57
 - Response 100, 101, 102, 103, 104, 105, 106, 107, 108, 109, 110, 111, 175

-
- Router 78, 79, 84, 85, 169, 175
 - SCADA** 154, 156, 175
 - Segment length 73
 - Sequence number 89
 - Shared Ethernet 79
 - Socket 176
 - Socket connections
 - max. number 49
 - Standard
 - Cabling 77
 - EN 50173, ISO 11801, TIA 568-A 77
 - Standardization
 - IEEE 802.3 71
 - Structured cabling 77, 176
 - Subnet 88, 176
 - mask 87, 177
 - Subscriber ID 87
 - Switch 72, 78, 177
 - Switched Ethernet 80, 168, 177
 - TCP/IP 71
 - Tear-off label 44, 53
 - Topology 73, 75, 77, 78, 170, 171, 176
 - Star 75
 - Transmission
 - media 73
 - rate 71
 - speed 73
 - unlocking lug 18
 - Watchdog
 - Register 115
 - word-alignment 133
 - WWW 92



WAGO Kontakttechnik GmbH & Co. KG

Postfach 2880 • D-32385 Minden
Hansastraße 27 • D-32423 Minden

Phone: 05 71/8 87 – 0

Fax: 05 71/8 87 – 1 69

E-Mail: info@wago.com

Web: <http://www.wago.com>
