

PART NO.
20021111

NOTES:
 1.MATERIAL:
 HOUSING: HIGH TEMPERATURE THERMOPLASTIC, UL94-V0 BLACK.
 TERMINAL: COPPER ALLOY
 2.THE HOUSING WILL WITHSTAND EXPOSURE TO 260°C PEAK TEMPERATURE FOR 10 SECONDS IN A WAVE SOLDER OR VAPOR PHASE REFLOW OVEN.
 3.THIS PRODUCT MEETS EUROPEAN UNION DIRECTIVES AND OTHER COUNTRY REGULATIONS AS DESCRIBED IN GS-22-008.
 4.PRODUCT SPEC: GS-12-629
 5.PACKAGE SPEC: GS-14-1420

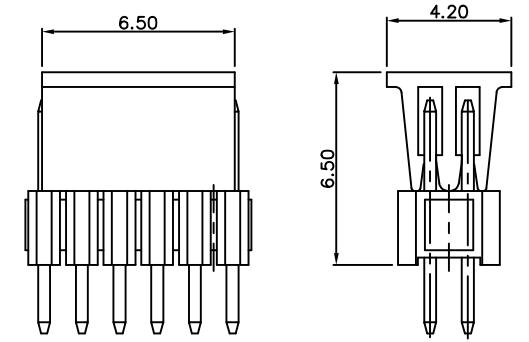
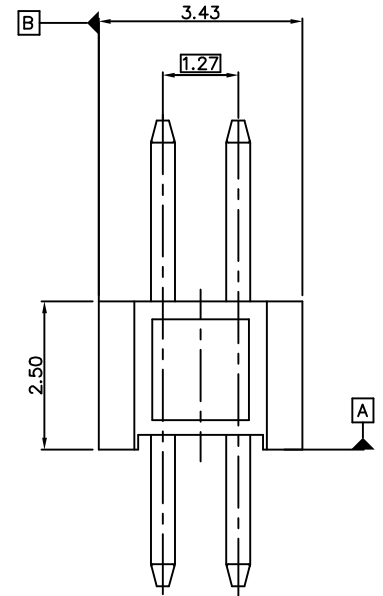
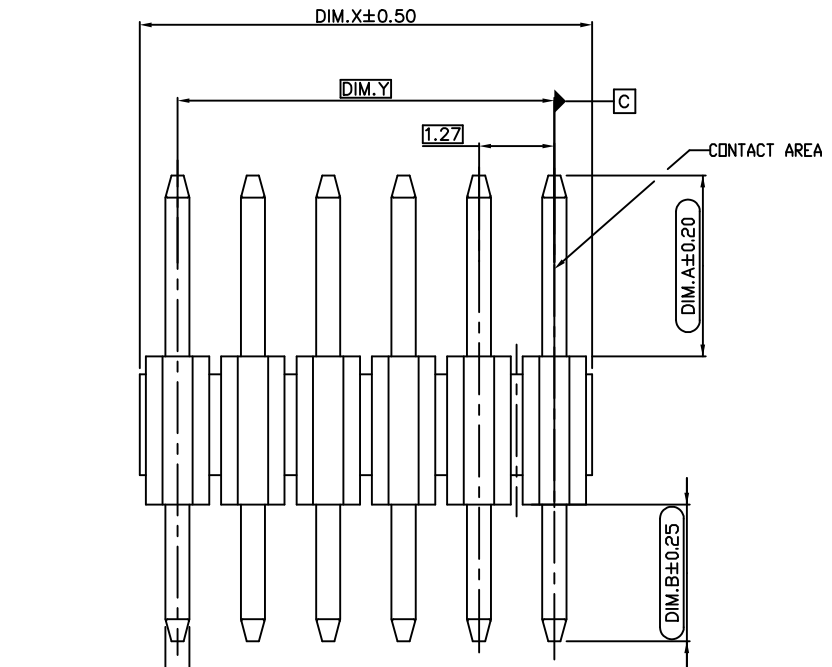

PRODUCT WITH CAP

SQ 0.41 TYP.
 $\phi \text{ } \varnothing 0.30 \text{ A B C}$

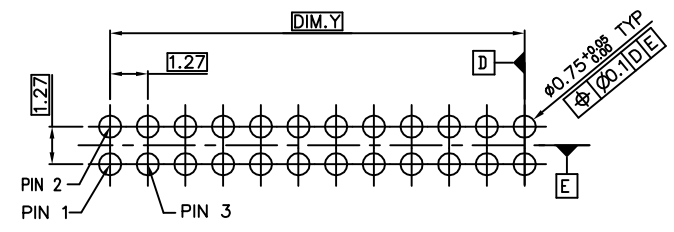
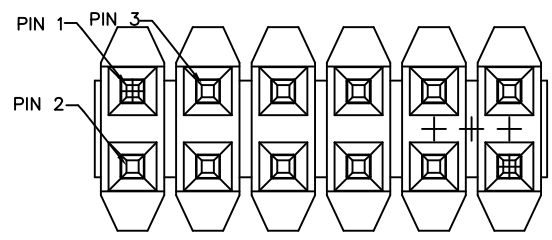

RECOMMENDED PCB LAYOUT

SCALE 5.0

mat'l. code		surface ISO 1302 ✓		tolerance ISO 406 ISO 1101		projection		product family	
ltr		ecn no		dr		date		MINITEK127®	
E		ELX-N-23548		TIM		03/21/16		title	
F		ELX-N-25883		TONY		01/11/17		UNSHROUDED HDR VT TH	
G		ELX-N-27768		TONY		08/18/17		scale 1:1	
H		ELX-N-40994-1		YY		05/24/21		dr	
J		ELX-N-49660		SF		11/02/23		eng	
								chr	
								appd	
sheet		revision		J		J		dwg no	
index		sheet		1		2		sheet 1 of 2	
								size	
								A3	
								type	
								Product Customer Drawing	



PART NO.	POS.	DIM.X	DIM.Y
20021111-XXX04XXLF	2 X 2	2.54	1.27
20021111-XXX06XXLF	2 X 3	3.81	2.54
20021111-XXX08XXLF	2 X 4	5.08	3.81
20021111-XXX10XXLF	2 X 5	6.35	5.08
20021111-XXX12XXLF	2 X 6	7.62	6.35
20021111-XXX14XXLF	2 X 7	8.89	7.62
20021111-XXX16XXLF	2 X 8	10.16	8.89
20021111-XXX18XXLF	2 X 9	11.43	10.16
20021111-XXX20XXLF	2 X 10	12.70	11.43
20021111-XXX22XXLF	2 X 11	13.97	12.70
20021111-XXX24XXLF	2 X 12	15.24	13.97
20021111-XXX26XXLF	2 X 13	16.51	15.24
20021111-XXX28XXLF	2 X 14	17.78	16.51
20021111-XXX30XXLF	2 X 15	19.05	17.78
20021111-XXX32XXLF	2 X 16	20.32	19.05
20021111-XXX34XXLF	2 X 17	21.59	20.32
20021111-XXX36XXLF	2 X 18	22.86	21.59
20021111-XXX38XXLF	2 X 19	24.13	22.86
20021111-XXX40XXLF	2 X 20	25.40	24.13
20021111-XXX42XXLF	2 X 21	26.67	25.40
20021111-XXX44XXLF	2 X 22	27.94	26.67
20021111-XXX46XXLF	2 X 23	29.21	27.94
20021111-XXX48XXLF	2 X 24	30.48	29.21
20021111-XXX50XXLF	2 X 25	31.75	30.48
20021111-XXX52XXLF	2 X 26	33.02	31.75
20021111-XXX54XXLF	2 X 27	34.29	33.02
20021111-XXX56XXLF	2 X 28	35.56	34.29
20021111-XXX58XXLF	2 X 29	36.83	35.56
20021111-XXX60XXLF	2 X 30	38.10	36.83
20021111-XXX62XXLF	2 X 31	39.37	38.10
20021111-XXX64XXLF	2 X 32	40.64	39.37
20021111-XXX66XXLF	2 X 33	41.91	40.64
20021111-XXX68XXLF	2 X 34	43.18	41.91
20021111-XXX70XXLF	2 X 35	44.45	43.18
20021111-XXX72XXLF	2 X 36	45.72	44.45
20021111-XXX74XXLF	2 X 37	46.99	45.72
20021111-XXX76XXLF	2 X 38	48.26	46.99
20021111-XXX78XXLF	2 X 39	49.53	48.26
20021111-XXX80XXLF	2 X 40	50.80	49.53
20021111-XXX82XXLF	2 X 41	52.07	50.80
20021111-XXX84XXLF	2 X 42	53.34	52.07
20021111-XXX86XXLF	2 X 43	54.61	53.34
20021111-XXX88XXLF	2 X 44	55.88	54.61
20021111-XXX90XXLF	2 X 45	57.15	55.88

PART NO.	POS.	DIM.X	DIM.Y
20021111-XXX92XXLF	2 X 46	58.42	57.15
20021111-XXX94XXLF	2 X 47	59.69	58.42
20021111-XXX96XXLF	2 X 48	60.96	59.69
20021111-XXX98XXLF	2 X 49	62.23	60.96
20021111-XXXA0XXLF	2 X 50	63.50	62.23

20021111 - X X X XX X X LF

- LEAD FREE
- PLATING OPTIONAL
 - 1: GOLD FLASH AT CONTACT, 1.27um MIN. MATTE TIN AT TAIL
 - 2: GOLD FLASH AT CONTACT, GOLD FLASH AT TAIL
 - 4: 0.25um Au MIN. AT CONTACT, 1.27um MIN.MATTE TIN AT TAIL
 - 5: 0.25um Au MIN. AT CONTACT, GOLD FLASH AT TAIL
 - 6: 0.38um GXT MIN. AT CONTACT, 1.27um MIN.MATTE TIN AT TAIL
 - 7: 0.38um GXT MIN. AT CONTACT, GOLD FLASH AT TAIL
 - 8: 0.76um GXT MIN. AT CONTACT, 1.27um MIN.MATTE TIN AT TAIL
 - 9: 0.76um GXT MIN. AT CONTACT, GOLD FLASH AT TAIL
- PACKING STYLE
 - T: TUBE
 - Q: TAPE & REEL WITHOUT CAP
 - C: TAPE & REEL WITH CAP
- PIN NO. SEE TABLE
- MATING LENGTH(DIM.A)
 - 0: 3.05MM
 - 1: 1.50MM
- TAIL LENGTH(DIM.B)
 - 0: 2.30MM (FOR 1.6MM PCB)
 - 1: 1.60MM (FOR 1.0MM PCB)
 - 2: 2.70MM (FOR 2.0MM PCB)
 - 3: 1.00MM (FOR 0.55MM PCB)
- RESERVE CODE
 - 0: STANDARD

Amphenol FCI

© 2016 AFCE

mat'l. code		surface	tolerance	projection	product family
		ISO 1302	ISO 406 ISO 1101		MINITEK127®
ltr	ecn no	dr	date	tolerances unless otherwise specified	title
J				angles linear	UNSHROUDED HDR VT TH
				0±2'	mm
				.0±.30	scale 1:1
				.00±.20	
				.000±.10	
dr	ZK HU	09/28/12			Amphenol FCI
eng	ZK HU	09/28/12			dwg no
chr	BIAN RICK	09/28/12			sheet 2 of 2
app'd	BIAN RICK	09/28/12			size
					20021111
					A3
					type Product Customer Drawing
sheet index	revision sheet				

A
B
C
D

A
B
C
D