

12-channel low quiescent current LED driver



WLCSP20



QFN20 3x3

Features

- Supply range from 2.6 V to 5 V
- 12 channels for single LED
- 20 mA current capability per channel
- 1% (typ.) current matching at 16 mA and 2% (typ.) at 2.5 mA
- 1.8 V compatible I²C control interface
- 8-bit analog dimming individual control
- 12-bit local PWM resolution
- 8 programmable patterns
- Programmable pattern sequence
- Synchronization for multi-device application
- Phase shifting between channels
- Open LED detection
- Overtemperature protection
- 8 configurable I²C slave addresses plus global address
- Fault flag pin

Applications

- RGB LED lighting, fade-in and fade-out breathing effect, indicator lights for:
 - Wearable electronics
 - Battery powered devices
 - Portable accessories

Maturity status link

[LED1202](#)

Description

The **LED1202** is a 12-channel low quiescent current LED driver; it guarantees 5 V output driving capability and each channel is able to provide up to 20 mA with a headroom voltage of 350 mV (typ.) only. The output current can be adjusted separately for each channel by 8-bit analog and 12-bit digital dimming control.

A slow turn-on and turn-off time improves the system low noise generation performance; moreover, the phase shifting function helps to reduce the inrush current. Eight patterns can be stored in the internal registers for automatic sequencing without MCU intervention.

The pattern sequence can be also configured for duration time and number of repetition. For multi-device applications, a common clock domain can be shared for timing synchronization. The device includes thermal shutdown and open LED detection.

The device I²C interface is based on fast mode specification and works up to 400 kHz. Eight I²C addresses are possible by using two configuration pins (A0/A1) only. The **LED1202** is available in WLCSP20 package 1.71 x 2.16 x 0.5 mm with 0.4 mm pitch and in QFN20 3x3 package 3 x 3 x 0.6 mm with 0.5 mm pitch.

1 Introduction

The LED1202 is a 12-channel LED driver with high current accuracy.

1.1 Block diagram

Figure 1. LED1202 simplified block diagram

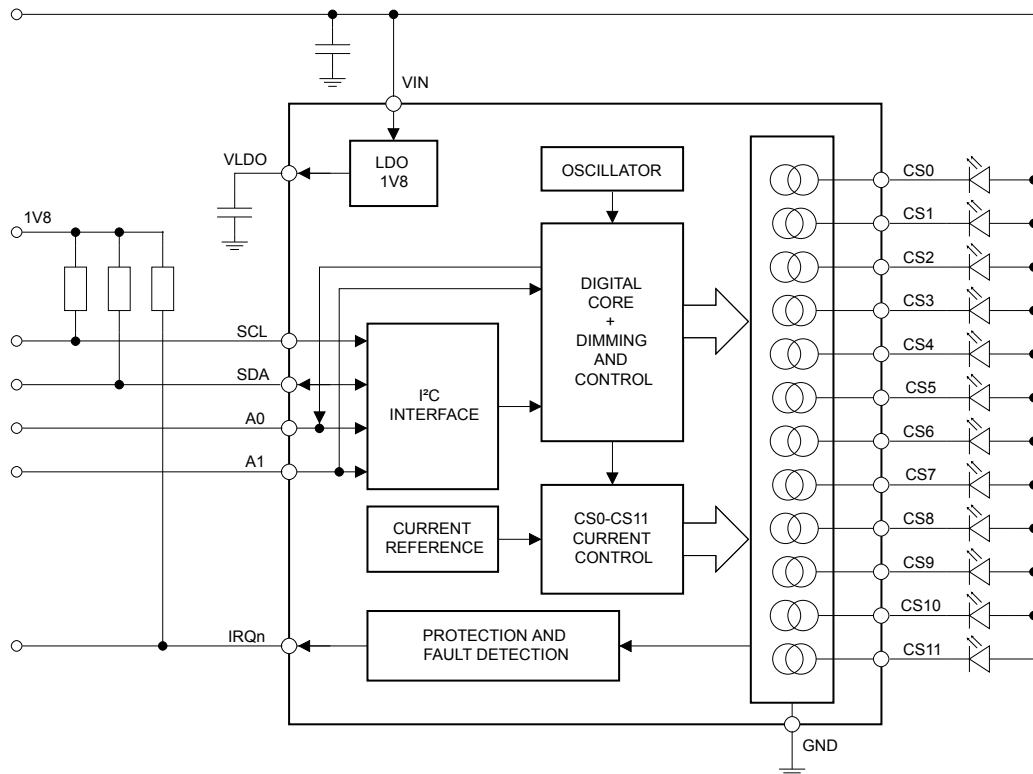

2 Pinout and pin description

WLCSP20 and QFN20 3x3 package pinout and pin description.

2.1 WLCSP20 package – ball assignment

Figure 2. LED1202JR ball assignment (top and marking side view)

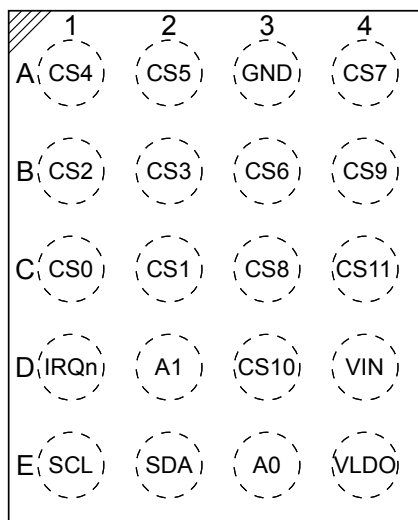

2.2 QFN20 3x3 package – pin assignment

Figure 3. LED1202QTR pin assignment (top and marking side view)

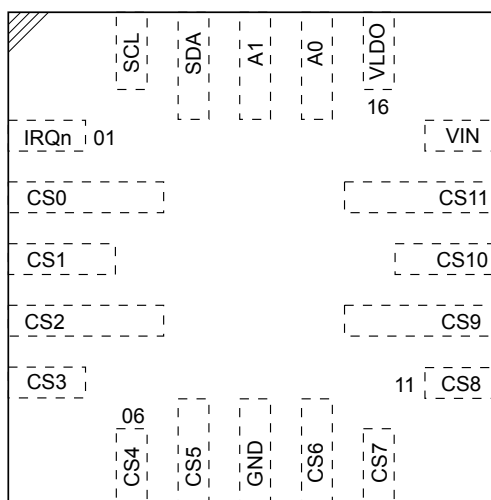

2.3 Pin description

Table 1. Pin description

I/O balls/pins	Name	Description
D4 / 15	VIN	Power supply input
A3 / 08	GND	Power ground
E1 / 20	SCL	I ² C clock signal
E2 / 19	SDA	I ² C data signal
D1 / 01	IRQn	Interrupt output (open-drain) – active low
E3 / 17	A0	Address pin 0 / internal clock output
D2 / 18	A1	Address pin 1 / external clock input
E4 / 16	VLDO	LDO capacitor output
C1 / 02	CS0	Current sink 0 input
C2 / 03	CS1	Current sink 1 input
B1 / 04	CS2	Current sink 2 input
B2 / 05	CS3	Current sink 3 input
A1 / 06	CS4	Current sink 4 input
A2 / 07	CS5	Current sink 5 input
B3 / 09	CS6	Current sink 6 input
A4 / 10	CS7	Current sink 7 input
C3 / 11	CS8	Current sink 8 input
B4 / 12	CS9	Current sink 9 input
D3 / 13	CS10	Current sink 10 input
C4 / 14	CS11	Current sink 11 input

3 Electrical characteristics

3.1 Maximum ratings

Table 2. Absolute maximum ratings

Symbol	Parameter	Value	Unit
V_{IN}	LED driver input voltage	-0.3 to 6	V
$V_{SDA}, V_{SCL}, V_{IRQn}$	Digital domain voltages	-0.3 to 6	V
$V_{CS0-CS11}$	LED outputs	-0.3 to 6	V
V_{LDO}, V_{A0}, V_{A1}	Digital domain voltages	-0.3 to 6	V
ESD	Human body model (HBM) – JESD22-A114-B	±2000	V

Note: Absolute maximum ratings are those values beyond which damage to the device may occur. Functional operation under these conditions is not implied.

3.2 Thermal information

Table 3. Thermal data

Symbol	Parameter		Value	Unit
T_a	Operative free-air temperature range		-40 to +85	°C
T_J	Operative junction temperature range		-40 to +125	°C
T_{STG}	Storage ambient temperature range		-55 to +150	°C
θ_{ja}	Thermal resistance junction-ambient ⁽¹⁾	WLCSP20 1.71x2.16 mm	89.5	°C/W
		QFN20 3x3	65.3	°C/W
θ_{jb}	Thermal resistance junction-board ⁽¹⁾	WLCSP20 1.71x2.16 mm	53.0	°C/W
		QFN20 3x3	18.1	°C/W
θ_{jc}	Thermal resistance junction-case ⁽¹⁾	WLCSP20 1.71x2.16 mm	13.8	°C/W
		QFN20 3x3	19.4	°C/W

1. These parameters correspond to Standard JEDEC PCB (2S2P) as per JESD 51 specification.

3.3 LED1202 electrical characteristics

Table 4. LED1202 electrical characteristics $V_{IN} = 3.3\text{ V}$, SDA, SCL and IRQn = 1.8 V, $T_a = 25\text{ }^\circ\text{C}$, RC load = 50 Ω /10 pF, unless otherwise specified.

Symbol	Parameter	Test conditions	Min.	Typ.	Max.	Unit
V_{IN}	Operating input voltage		2.6		5	V
I_Q	Quiescent current	EN='0'		4	8	μA
I_{IN}	Supply current	EN='1' $I_{CS0-CS11} = 16\text{ mA}$		0.8	2.0	mA
V_{IN_UVLO}	Undervoltage lockout threshold	V_{UVLOR} (V_{IN} is rising)			2.5	V
		V_{UVLOF} (V_{IN} is falling)	2.1			V
V_{LDO}	LDO output voltage	$I_{out} = 10\text{ mA}$; $V_{IN} = 2.6\text{ V}$		1.8		V
I_{LDO_SH}	LDO short-circuit current	V_{out} forced at 1.6 V			200	mA
V_{CS_MIN}	Minimal headroom voltage	$I_{CS0-CS11} = 0.985 * I_{CSMAX}$		350		mV
V_{CS_MAX}	Maximum output voltage	$I_{CS0-CS11} = 0\text{ mA}$			5	V
I_{CS_SET}	Analog dimming range ⁽¹⁾		1		20	mA
$\Delta I_{CS0-CS11}$	Current matching between channels ⁽²⁾	$I_{CS0-CS11} = 16.0\text{ mA}$ @ $V_{CS} = 1\text{ V}$		$\pm 1\%$	± 3	%
		$I_{CS0-CS11} = 2.5\text{ mA}$ @ $V_{CS} = 1\text{ V}$		$\pm 2\%$	± 3	%
ΔI_{CS}	Absolute channel accuracy	$I_{CS0-CS11} = 16.0\text{ mA}$ @ $V_{CS} = 1\text{ V}$			± 4	%
		$I_{CS0-CS11} = 2.5\text{ mA}$ @ $V_{CS} = 1\text{ V}$			± 6	%
f_{PWM}	Output digital dimming frequency			220		Hz
D_{PWM}	Output dimming duty-cycle range		0		100	%
D_{PWM_STEP}	Output dimming duty-cycle step			1/4095		
t_{PWM_ON-MIN}	Minimum output pulse ON-time			1		μs
t_{SHIFT}	Phase shift time between channels	SHFT = '1'		$1/12 * t_{f_{PWM}}$		s
t_{INIT}	Initialization time to start lighting	EN = '0' \rightarrow '1' Pattern0 default condition		6		ms
T_{SHDN}	Thermal shutdown			150		$^\circ\text{C}$
V_{OPEN_TH}	Open LED detection threshold	$I_{CS0-CS11} > 1\text{ mA}$		100		mV
V_{IRQn}	Output low level	$I_{TEST} = 1\text{ mA}$			0.4	V
I_{IRQn_LK}	Input leakage current	$V_{IRQn} = 5\text{ V}$			1	μA
I²C compatible interface						
V_{IH}	High level input voltage		1.26			V
V_{IL}	Low level input voltage				0.54	V
V_{OL}	Low level output voltage	$I_{TEST} = 5\text{ mA}$			0.4	V

Symbol	Parameter	Test conditions	Min.	Typ.	Max.	Unit
C _{IO}	IO pin capacitance				10	pF
f _{SCL}	SCL clock frequency				400	kHz
t _{LOW}	Minimum clock low period		1.3			μs
t _{HIGH}	Minimum clock high period		600			ns
t _F	SDA and SCL fall time				300	ns
t _R	SDA and SCL rise time				300	ns
t _{HD:STA}	Start condition hold time		600			ns
t _{SU:STA}	Start condition setup time		600			ns
t _{SU:DAT}	Data setup time		100			ns
t _{HD:DAT}	Data hold time		0			μs
t _{SU:STO}	Stop condition setup time		600			ns
t _{BUF}	Minimum delay between operations		1.3			μs

1. The correspondence between the programmed I_{LED} and output current is not guaranteed for $I_{LED} < I_{CS_SET}$ Min.
2. $\Delta I_{CS0-CS11} = ((I_{CSx} - I_{CSavg}) / I_{CSavg}) * 100$; $I_{CSavg} = (\sum I_{CSx}) / 12$

3.4 Headroom voltage

The minimum headroom voltage is not constant, it changes according to LED current value. The typical characteristic at 25 °C ambient temperature is shown in the figure below.

In order to improve the accuracy and ground noise rejection at low current, the output stage implements two different current sink branches, that is why the curve has a double slope.

The threshold to switch between the branches is the I_{LEDx} (registers from address 09h to 14h) value of 48d (3.76 mA).

Figure 4. LED1202 headroom voltage vs. I_{LED}

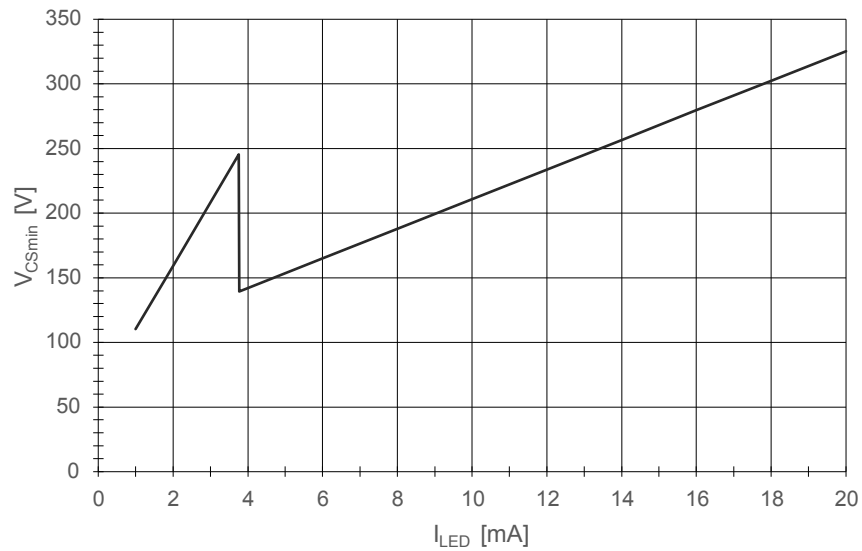

4 Device description

The LED1202 implements 12 low-side current generators with independent dimming control. Internal volatile memory allows the user to store up to 8 different patterns, each pattern is a particular output configuration in terms of PWM duty-cycle (on 4096 steps). While analog dimming (on 256 steps) is per channel but common to all patterns.

4.1 Device startup

Once the supply voltage V_{IN} is applied, the LED1202 executes some internal checks, afterwards it stops the oscillator and puts the internal LDO in quiescent mode. To start the device, EN bit must be set inside the “Device Enable” register at address 01h (see [Section 7.2 Device enable register](#)).

As soon as EN is set, the LED1202 loads the adjustment parameters from the internal non-volatile memory and performs an auto-calibration procedure in order to increase the output current precision.

Such initialization lasts about 6.5 ms.

4.2 Device reset

The LED1202 can be reset by software. The RST bit is inside the “Device Enable” register at address 01h (see [Section 7.2 Device enable register](#)). When RST bit is set all the register values are restored to default value as per a POR event. This bit is always read as zero since it is the POR value.

4.3 Device address selection

The LED1202 allows up to eight different local I²C addresses to be selected; furthermore, it has also a fixed global address:

- Global address – is factory pre-set and unchangeable for all devices (5Ch @ 7bit); it controls at the same time all the devices sharing the same I²C bus (only write is possible)
- Local address – it allows the user to control each single device according to the defined local address (read/write operations are possible)

A read operation using a global address produces an ACK as reply to the valid address, but after that SDA line is not driven generating a “false” FFh data reply, instead of any register content.

Internal register read is allowed using one of the 8 selectable local addresses only; local address can be defined using only two pins (A0 and A1) connected, as per the following table:

Table 5. LED1202 local address table

A1	A0	I ² C slave address (7 bit)
GND	GND	58h
GND	VI2C	59h
VI2C	GND	5Ah
VI2C	VI2C	5Bh
GND	SDA	5Dh
GND	SCL	5Eh
VI2C	SDA	5Fh
VI2C	SCL	60h

Local address is acquired and latched inside the device at first acknowledge. After that, any modification of A0 and/or A1 connection has not effect on the device I²C local address.

4.4 LED channel selection

The enabling or disabling of channels is performed on “Channel Enable” registers at addresses 02h and 03h. There are 8 + 4 enable bits available, one for each corresponding channel. “Channel Enable” registers are detailed on [Section 7.3 Channel enable registers](#). EN bit on “Device Enable” register at address 01h is the global enable of the device that has higher priority than single channel enable bits (see [Section 7.2 Device enable register](#)).

4.5 Output dimming modes

There are two main methods for dimming LED light: changing the output DC current value (analog dimming) or modifying the output current duty-cycle (digital dimming). The two methods are not mutually exclusive and can be used at the same time to generate a specific channel by channel 20 bit depth dimming.

4.5.1 LED controlled by “CSx LED Current” registers (analog dimming)

The output DC current value can be adjusted by “CSx LED Current” registers (see [Section 7.8 LED current registers](#)). In this case, the LED brightness change is achieved by setting the output current in the range from 1 mA to 20 mA. “CSx LED Current” registers are between address 09h to 14h. Note that after POR, all output PWM values are set by default on “Pattern0CSx PWM” registers: PWML = 55 h, PWMH = 05 h; limiting the maximum brightness reachable acting on analog dimming alone.

Figure 5. Analog dimming

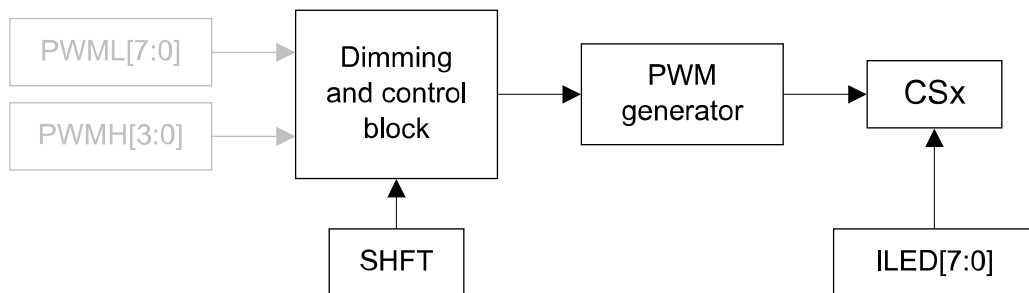

4.5.2 LED controlled by “PatternyCSx PWM” registers (digital dimming)

The LED brightness can be adjusted by varying the output duty-cycle. The duty-cycle is programmed by “PatternyCSx PWM” registers (see [Section 7.11 Pattern PWM configuration registers](#)). Note that “CSx LED Current” registers (see [Section 7.8 LED current registers](#)) are set by default to 27h, limiting the output current DC value to about 3.06 mA. To avoid any brightness artefacts, when SHFT=1 and/or EN=1, the update of “PatternyCSx PWM” registers should be synchronized with SOF (start of frame) interrupt (refer to [Section 4.10.4 Start of frame interrupt](#) for more details).

Figure 6. Digital dimming

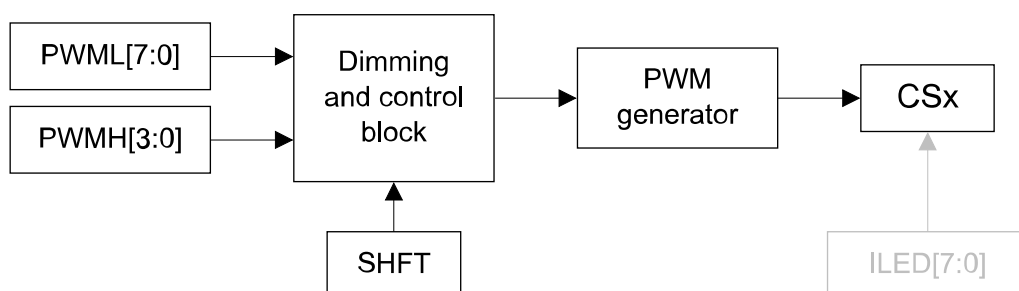

4.5.2.1 Global digital dimming configuration

Setting GCTRL bit in “Configuration” register at address 04h (see [Section 7.4 Configuration register](#)), the PWM value set for the channel CS0 (PatternyCS0) is applied to all channels (same digital dimming level). This is valid for any pattern selected by PATSEL[2:0] in “Configuration” register (refer to [Section 4.7 Pattern selection and configuration](#) for more details).

During the execution of a pattern sequence (refer to [Section 4.8 Pattern sequence configuration](#) for more details) the PatternyCS0 setting of the running pattern is applied to all channels (CS0-CS11).

4.5.3 LED controlled by “CSx LED Current” and “PatternyCSx PWM” registers

The full control of LED brightness can be achieved by setting both the output current level (“CSx LED Current” registers, see [Section 7.8 LED current registers](#)) and output current duty-cycle using “PatternyCSx PWM” registers (see [Section 7.11 Pattern PWM configuration registers](#)).

Figure 7. Analog+digital dimming

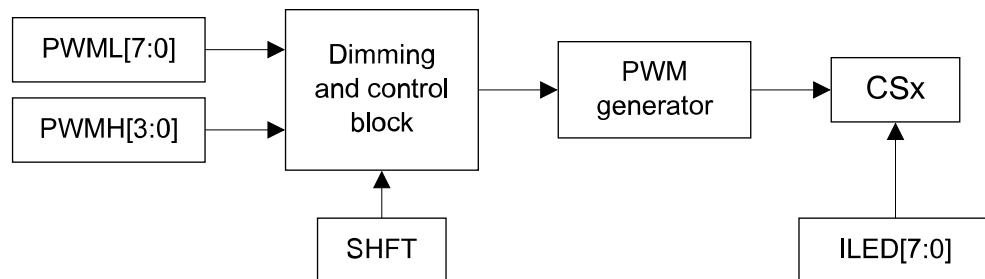

4.6 Phase-shift

Phase-shift feature delays channel power-on to minimize peak load current. This delay reduces voltage ripple on the LED power supply rail and allows the smallest filtering capacitor to be used. This feature is controlled by SHFT bit in “Configuration” register (see [Section 7.4 Configuration register](#)). The shift time (t_{SHIFT}) is the delay between two contiguous channels and it is defined as follows:

$$t_{shift} = 1 / (12 \times f_{PWM}) = 1 / (12 \times 220) \approx 380 \mu s$$

To have the phase-shift properly executed, without LED blink artefacts, SHFT=1 has to be set before enabling the device with EN=1.

When SHFT is set, to avoid any brightness artefact, PWM value change (from CS11 to CS0) must be synchronized with SOF (start of frame) interrupt (refer to [Section 4.10.4 Start of frame interrupt](#) for more details).

While pattern change can be made at any time since the new selected pattern is automatically synchronized by the LED1202 at the beginning of the new frame.

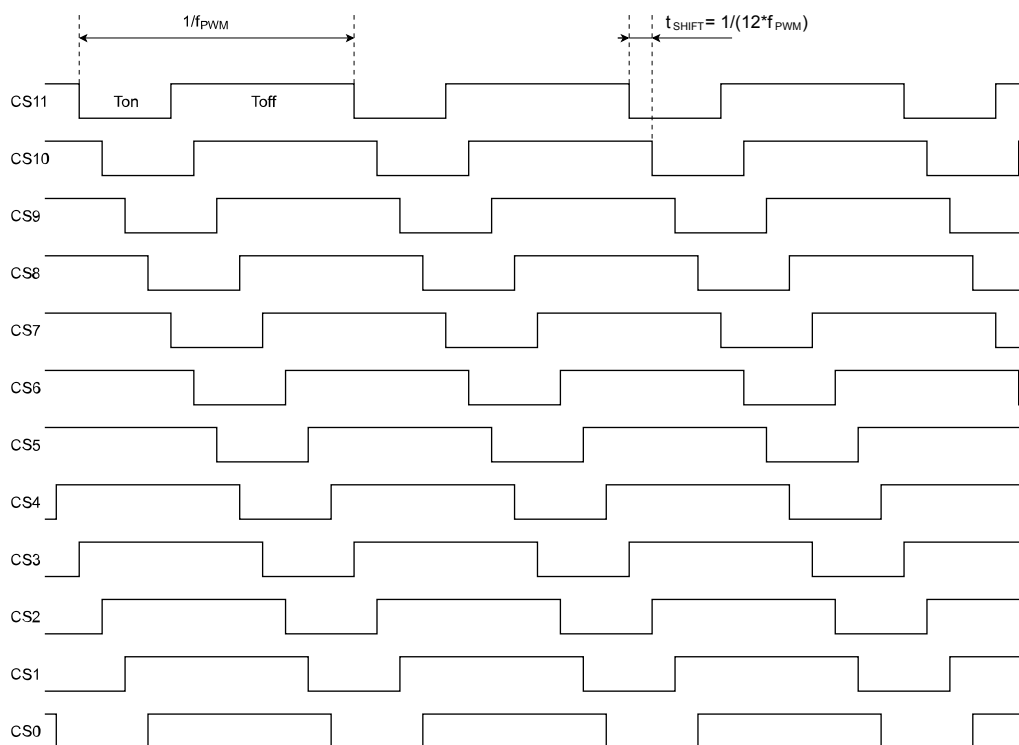
Figure 8. Phase-shift feature scheme

4.7 Pattern selection and configuration

Active pattern can be selected in “Configuration” register at 04h (see [Section 7.4 Configuration register](#)) by PATSEL[2:0] bits, choosing among 8 different patterns. A pattern is composed of the PWM value for each output stored into “PatternyCSx PWM” registers. Analog dimming ILEDx (registers from 09h to 14h) is per channel and it is common to all patterns.

4.8 Pattern sequence configuration

The pattern sequence can be enabled in “Configuration” register at 04h (see [Section 7.4 Configuration register](#)) by using PATS bit and setting PATSR bit starts in the same register. PATS bit can be set at any time, even when EN=0, but after setting all outputs go OFF waiting for the sequence start. It is not possible to set PATSR bit when EN=0, in this case it is cleared.

Since PATS and PATSR bits are in the same register they can be set at the same time, there is no point in setting PATS earlier than PATSR. While setting PATSR earlier than PATS is not possible, in this case PATSR is cleared. PATSR bit is set by user to start the pattern sequence, afterward it indicates (when it is read by user) that pattern sequence is being run whether set or not if cleared.

The duration of each single pattern of the sequence can be configured from about 22.2 ms to 5660 ms, by step of 22.2 ms, in “Pattern y Duration” registers (see [Section 7.10 Pattern duration registers](#)) at address 16h to 1Dh.

22.2 ms step is generated using the internal oscillator as time base and, in case of application with multiple devices, all the devices should be synchronized (refer to [Section 4.9.1 Common clock domain configuration](#) for more details) to have a single master oscillator.

The pattern sequence can be repeated for a programmable number of times (from 1 to 254) or in infinite loop, it depends on the value written in “Pattern Sequence Repetition” register at 15h (see [Section 7.9 Pattern sequence repetition register](#)). Note: the value 00h is not allowed for such registers.

The pattern sequence runs always from pattern 0 to pattern 7, independently of PATSEL[2:0] value. It is possible to skip a pattern writing 00h into “Pattern y Duration” register, so the sequence moves to the next one; in case all patterns are set to skip, the device clears PATSR immediately.

When the pattern sequence runs, the displayed pattern can be checked by reading PATSEL bits (used as status bits when PATSR=1). PATSEL bits can be written during the pattern sequence execution, but the new selected

pattern becomes active at the end of the pattern sequence (PATSR=0) only and visible only when the sequence is disabled by PATS=0.

After setting EN=1, the device performs some auto adjustments, if the user sets PATSR during this time the pattern sequence starts at the end of such auto adjustments only. As a consequence, if read by user, PATSR is zero up to the end of auto adjustment since the sequence has not started yet and so it is not ongoing.

If "Pattern y Duration" and/or "Pattern Sequence Repetition" are modified during the pattern sequence execution, new values are updated only when the sequence has been completed or stopped, in case of infinite loop.

At the end of the pattern sequence, the device can be forced in disable by setting AUTODIS bit in "Configuration" register at 04h (see [Section 7.4 Configuration register](#)); in this manner, the internal oscillator is switched off.

Setting GCTRL bit in "Configuration" register forces the value "PatternyCS0 PWM" to all outputs, this feature can be used, for example, in backlight applications where normally all LEDs use the same dimming.

4.9 Device synchronization

When in one application there is more than one device, the way to activate all the devices at the same time is to set the EN bit in "Device Enable" register through the global address. In this manner all LEDs are lighted up and they are driven by those devices sharing the same I²C bus as they are controlled by a single device.

Global address is also important to launch the execution of complex pattern sequences which imply a lot of LEDs driven by more than one device.

4.9.1 Common clock domain configuration

The LED1202 generates internally the reference clock for all timings, from PWM period to pattern sequence duration time. The internal clock is stable and precise, but it cannot be absolutely the same for all production population. So, in those applications with multiple devices running a pattern sequence managed by more than one device, a device has to be selected as master and its clock has to be used as reference for all devices. This ensures, even in case of long duration time or infinite looping, a synchronicity of patterns managed by different devices.

I²C local address is set with A0 and A1 pins; the LED1202 latches the configured address after the first acknowledge of an appropriate I²C frame. After that, any level change on A0 and A1 has no effect on the device I²C local address, so pins can be used for different purposes.

Specifically to output internal clock (A0) and to input external clock (A1).

In a configuration with multiple devices and common clock domain there is a master device sharing its generated clock internally with all the other slave devices. The LED1202 supports clock distribution either in daisy chain or star configuration. In daisy chain configuration each device receives the clock from the previous one (master excluded) and provides it to the next, in star configuration master distributes the clock to all slaves in parallel.

Clock output can be enabled on pin A0 setting bit CLK_O_En, while clock input is enabled on pin A1 by bit CLK_I_En, both bits are in "clock configuration" register at address E0h (see [Section 7.12 Clock configuration register](#)).

4.10 Alarms and IRQ generation

Four device detections, fault or condition, can generate an interrupt on IRQn pin if it is not masked:

- Open LED
- Overtemperature
- Pattern end
- Start of frame

4.10.1 Open LED interrupt

When any used channel (CS0-CS11) goes to open condition, the respective CSx bit in “Open LED” status registers at 07h and 08h is set. If LED connection is restored the respective bit is not reset since it is latched and auto-cleared only by a read-back operation. The OPEN bit in “Fault and Status Interrupt” register (see [Section 7.6 Fault and status interrupt register](#)) is set as cumulative result of active channels open detection, it generates an interrupt on IRQn pin if OPEN_M bit in “Fault and Status Mask” register (see [Section 7.5 Fault and status mask register](#)) is 0 (OPEN flag mask not set). IRQn pin is reset after reading “Fault and Status Interrupt” register, while the CSx bit is cleared after “Open LED” status register read-back.

Open channel detection has a current threshold and deglitch, it works properly only if I_{LED} value is higher than 1 mA and PWM ON time is longer than about 14 μ s.

4.10.2 Overtemperature protection (OVTP) interrupt

An internal temperature sensor monitors continuously the IC junction temperature. If the junction temperature exceeds 150 °C (typ.) the device stops operating shutting down all the outputs, however the I²C interface stays active. The OVTP bit in “Fault and Status Interrupt” register (see [Section 7.6 Fault and status interrupt register](#)) is set.

Even if the temperature decreases, the respective fault bit is latched, this bit is auto-cleared by a read operation. The OVTP bit, when asserted, generates an interrupt on IRQn pin if not masked by OVTP_M bit “Fault and Status Mask” register (see [Section 7.5 Fault and status mask register](#)). Overtemperature detection has a deglitch of about 18 μ s.

4.10.3 Pattern end interrupt

The PAT bit on “Fault and Status Interrupt” register at address 06h (see [Section 7.6 Fault and status interrupt register](#)) is set when the pattern sequence is completed. This PAT bit generates an interrupt on IRQn pin if PAT_M bit of “Fault and Status Mask” register (see [Section 7.5 Fault and status mask register](#)) is not set. Interrupt is automatically cleared after “Fault and Status Interrupt” register read-back.

At the end of the pattern sequence, the bit PATSR is automatically cleared while bit PATS remains set and as a consequence all outputs remain OFF. If PAT bit is not masked, at the end of the sequence, the IRQn pin is driven and can be used as MCU interrupt. In this manner, the end of the sequence is quickly recognized making possible an immediate PATS bit clearing to display the pattern defined by PATSEL[2:0] instead of leaving all channels OFF.

4.10.4 Start of frame interrupt

SOF bit (Start of frame) in “Fault and Status Interrupt” register (see [Section 7.6 Fault and status interrupt register](#)) can be used to generate an interrupt on IRQn pin in order to change CSx PWM setting of running pattern without creating any brightness artefact. When not needed, SOF can be masked by SOF_M bit in in “Fault and Status Mask” register (see [Section 7.5 Fault and status mask register](#)).

When user wants to change CSx PWM settings of running pattern on fly and he wants that new CSx PWM settings are taken all simultaneously, since I²C CSs pattern PWM settings writing is done sequentially, the steps below need to be followed:

1. Unmask SOF bit;
2. Wait for the interrupt (generated at the beginning of the frame);
3. Update sequentially (using auto increment) CSx PWM settings of running pattern at 220 Hz. In this way all the registers are updated within a PWM period and so at the beginning of next frame all CSx channels start simultaneously with newer PWM settings;
4. Set again SOF_M mask bit, to avoid unnecessary interrupt.

Because SOF signal is synchronized with the start of CS0 frame, in case SHFT bit is set, user has to do the same procedure described before, but, for point 3, he has to update all CSx PWM settings starting from CS11 PWM settings down to CS0 PWM settings. This means that auto increment is not possible and the time available to update each CSx PWM registers is 380 μ s.

Since each CSx PWM value is on 2 registers, the I²C frame required for a single CSx PWM update lasts 36 clocks, meaning at least 360 μ s with I²C in standard mode (refer to [Section 5.2 I²C bus interface](#) for more details) and 90 μ s in fast mode. In both cases a time shorter than t_{SHIFT} allows the new CSx PWM value to be applied exactly the frame afterward.

Figure 9. SOF position in case of SHFT=1

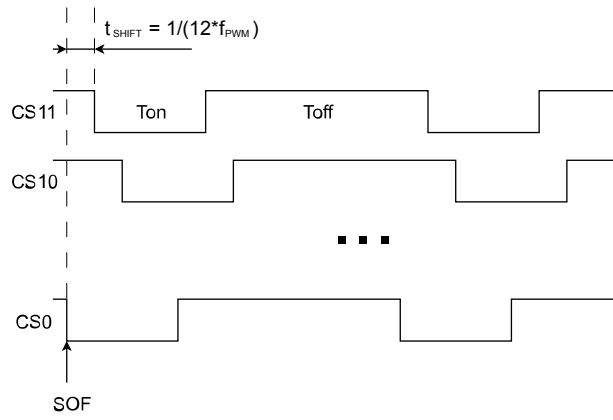

5 Device interface

This section describes the LED1202 device interfaces.

5.1 IRQn output pin

The interrupt request (IRQ) pin is used to inform the system when an alarm event occurs. This IRQn pin is open-drain active low. “Fault and Status Interrupt” register (see [Section 7.6 Fault and status interrupt register](#)) filtered by “Fault and Status Mask” register (see [Section 7.5 Fault and status mask register](#)) controls this pin. The IRQn pin status is reset after “Fault and Status Interrupt” register read-back. When this pin is used to manage SOF (start of frame) signal to synchronize PWM change, mainly when SHIFT is active, it had better temporary mask all the other alarms in “Fault and Status Mask” register.

5.2 I²C bus interface

The LED1202 is fully controlled, registers write and read, by I²C communication.

The I²C bus is a slave serial interface built with a data line (SDA) and a clock line (SCL):

- SCL: input clock used to shift the data.
- SDA: input/output bidirectional data transfer line.

The LED1202 device supports the following data transfer mode: standard mode (100 Kbit/s) and fast mode (400 Kbit/s) as defined in the I²C bus specifications.

I²C communication is composed of specific events on the bus:

- Start condition - it is a falling edge of SDA while SCL is HIGH level
- Slave addressing - it is the transmission (M→S) of the ID of the slave to be addressed (7-bit)
- Communication direction - it is one bit immediately following the slave ID: 0 for data writing (M→S) or 1 for data reading (S→M)
- Register addressing - it is the transmission (M→S) of the register address of the slave to be accessed (8-bit)
- Data bit - data are 8 bits per word driven either by MASTER or SLAVE depending on the communication moment
- Acknowledge - it is a LOW level on SDA line, driven by either SLAVE or MASTER depending on the communication direction
- Stop condition - it is a rising edge of SDA while SCL is HIGH level
- Restart condition - it is a new start condition which happens before a stop condition: it normally implies a change in the direction of the communication

Figure 10. I²C timing reference

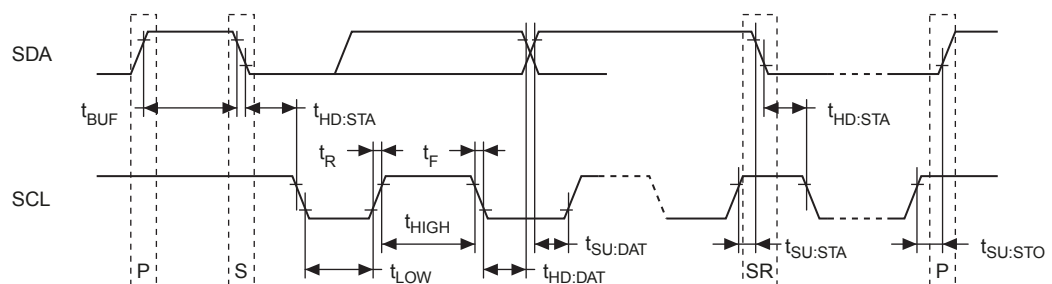

5.2.1 The LED1202 addressing

Since some applications could require more than a single LED1202 device, a method to differentiate each single device has been put in place using pins A0 and A1; refer to [Section 4.3 Device address selection](#) for more details.

5.2.2 Data validity

As shown in the figure below, the data on the SDA line must be stable during the high period of the clock. The HIGH and LOW state of the data line can only change when the clock signal on the SCL line is LOW.

Figure 11. Data validity on the I²C Bus

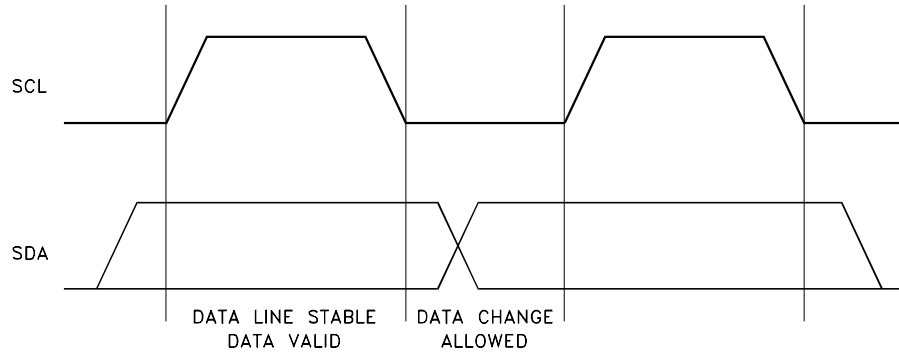

5.2.3 Start and stop conditions

Both DATA and CLOCK lines remain HIGH when the bus is not busy. As shown in the figure below, a START condition is a HIGH to LOW transition of the SDA line while SCL is HIGH. The STOP condition is a LOW to HIGH transition of the SDA line while SCL is HIGH. A STOP condition must be sent to the end of each communication. A START condition sent before a STOP condition is called RESTART and it is normally used to change the communication direction, typically from write to read.

Figure 12. Start and stop condition on the I²C Bus

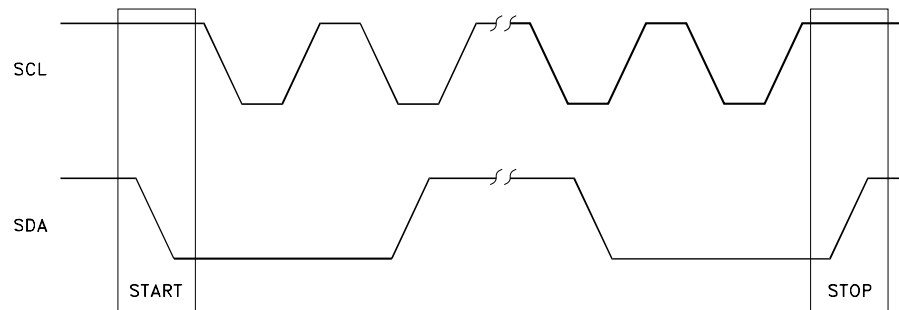

5.2.4 Byte format

Every packet transferred on the SDA line must contain 8 bits, each byte is followed by an acknowledge bit. Each clock pulse transfers a single bit of the packet, the data transfer is MSB first. The data on the SDA line must remain stable during the HIGH period of the clock pulse. Any change in the SDA line at this time is considered as a control signal (START or STOP condition).

Figure 13. Bit transfer

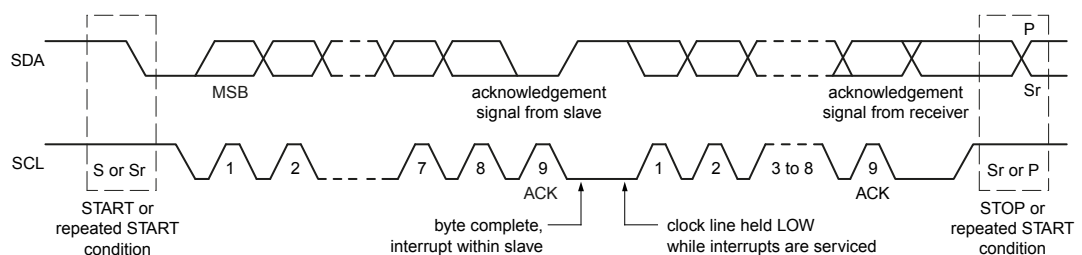

5.2.5 Acknowledge

The master (MCU) puts a resistive HIGH level on the SDA line during the acknowledge clock pulse (see the figure below). The peripheral (LED1202) has to pull down (LOW) the SDA line during the acknowledge clock pulse, so that the SDA line is stable LOW during this clock pulse. The peripheral, which has been addressed, has to generate an acknowledge pulse after the reception of each byte, otherwise the SDA line remains at the HIGH level during the ninth clock pulse duration. In this case, the master transmitter can generate the STOP information in order to abort the transfer. The LED1202 does not generate acknowledge if the V_{IN} supply is below the undervoltage lockout threshold.

Figure 14. Acknowledge on the I²C bus

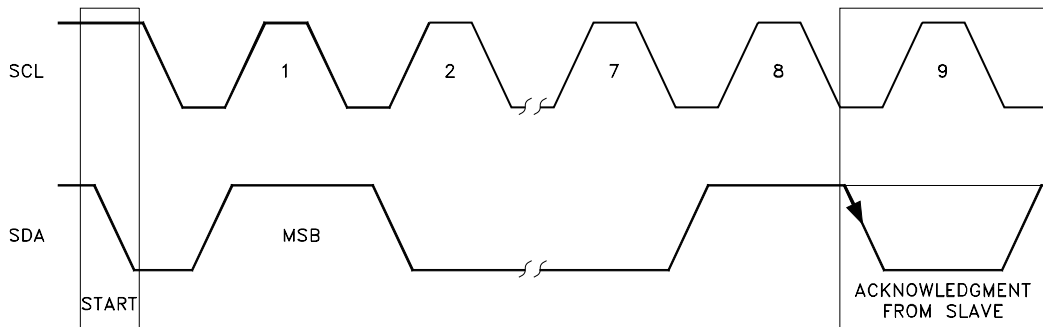

5.2.6 Interface protocol

The interface protocol is composed of (see figure below):

- Start condition (START)
- Device address (7 bit) + R/W bit (read = 1 / write = 0)
- Register address byte
- Sequence of N data packet (1 byte + acknowledge)
- Stop condition (STOP)

The register address byte determines the first register in which the read or write operation takes place. When the read or write operation is finished, the internal register address pointer is automatically incremented allowing multiple register writing or reading.

Figure 15. Interface protocol

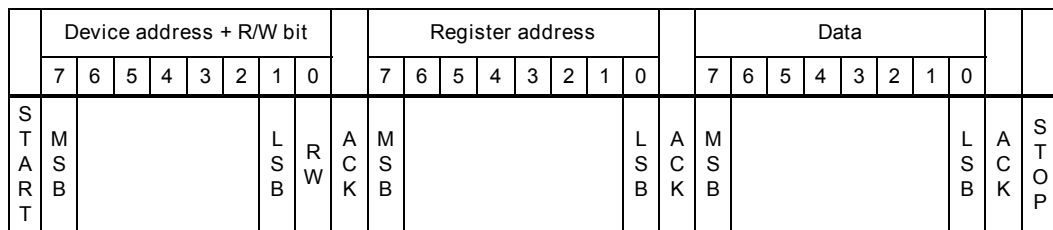

5.2.7 Writing to a single register

Writing to a single register starts with a START condition followed by the 7-bit device address of the LED1202, the 8th bit of the byte is the R/W bit, which is 0 for writing operations.

Then the master waits for the LED1202 acknowledge. Then the 8-bit address of register is sent to the LED1202, it is also followed by an acknowledge pulse. The last transmitted byte is the data to be written into the register, the LED1202 generates the acknowledge pulse at the end of packet. The master then generates a STOP condition and the communication is over. See figure below.

Figure 16. Writing to a single register

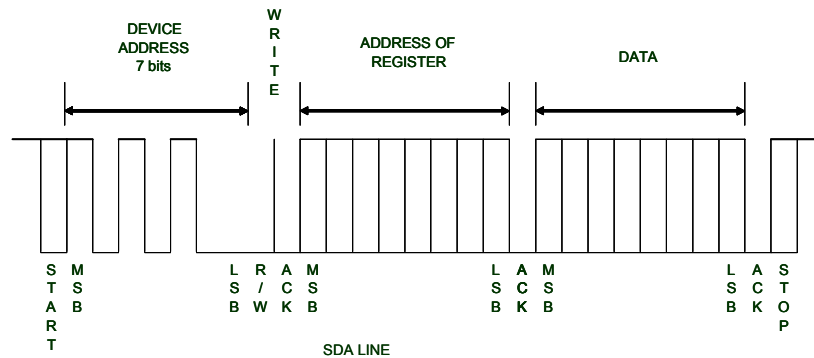

5.2.8 Writing to multiple registers with incremental addressing

It would not be easy to send several times the device address and the address of the register when writing to multiple sequential registers. The LED1202 supports writing to multiple registers with incremental addressing. When data is written to register, the internal address register pointer is automatically incremented, so the next data can be sent without repeating the device address and new register address. See figure below.

Figure 17. Writing to multiple registers

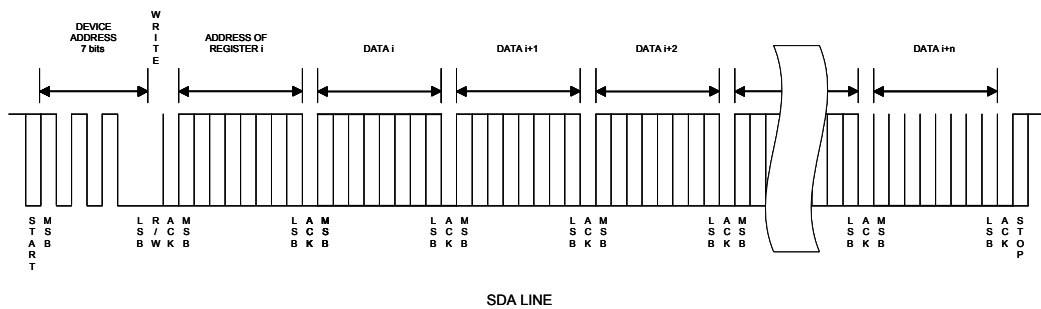

5.2.9 Reading from a single register

The reading operation starts with a START condition followed by the 7-bit device address of the LED1202, the 8th bit of the byte is the R/W bit, which has to be set to 0 as writing operations. The LED1202 confirms the receiving of the address + R/W bit by an acknowledge pulse. The address of the register, which should be read, is sent afterward and confirmed again by an acknowledge pulse of the LED1202. Then the master generates a RESTART condition and sends the 7-bit device address followed by the R/W bit, which now is set to 1 for reading operations. The LED1202 confirms the receiving of the address + R/W bit by an acknowledge pulse and starts to send the data to the master, one data per clock pulse always generated by master. No acknowledge pulse from the master is required after receiving the data. Then the master generates a STOP condition to terminate the communication. See figure below:

Figure 18. Reading from a single register

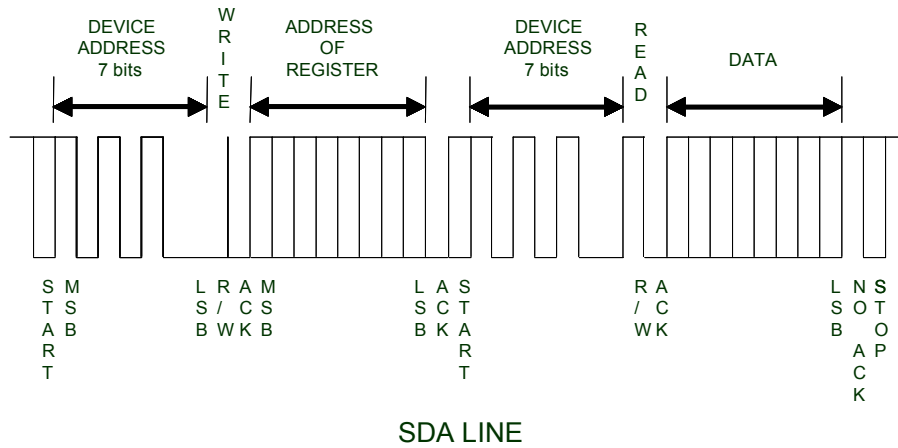

5.2.10 Reading from multiple registers with incremental addressing

Reading from multiple registers starts in the same way like reading from a single register. As soon as the first register is read, the internal register address pointer is automatically incremented. If the master generates an acknowledge pulse after receiving the data from the first register, then reading of the next register can start immediately without sending again the device address and the new register address. The last acknowledge pulse before the STOP condition is not required. See figure below.

Figure 19. Reading from multiple registers

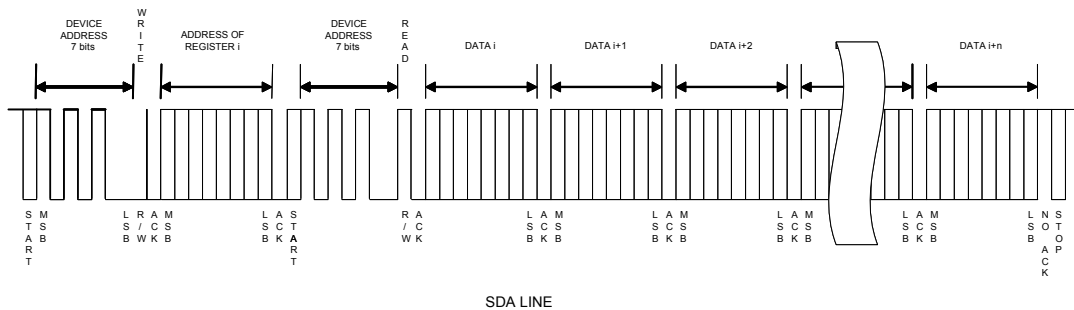

6 Application hints

The following section presents some application hints. Both the schematic and minimum components to properly run the application are shown.

6.1 Schematic diagram

The figure below shows the LED1202 typical application.

VLED value depends on the V_F of used LED. In case of Red LED with a V_F max. of 1.8 V we can choose a VLED of 2.3 V in order to guarantee enough headroom to current generator at 20 mA. While white LED with V_F max. of 3.5 V is used, we have to use 4 V as VLED.

There is always the possibility to connect VLED to V_{IN} in order to use a single power supply, in this case, the optimization of power dissipation is not easy and a ballast resistor in series to each LED could be necessary. I²C pins can support buses from 1V8 to 5 V, so the advice is to connect the pull-up resistors to the VI2C used by MCU in order to have a perfect matching. The value of pull-up resistors could be adapted for different VI2C to match V_{IH} and V_{IL} level and respect I²C specifications.

Figure 20. LED driver schematic diagram

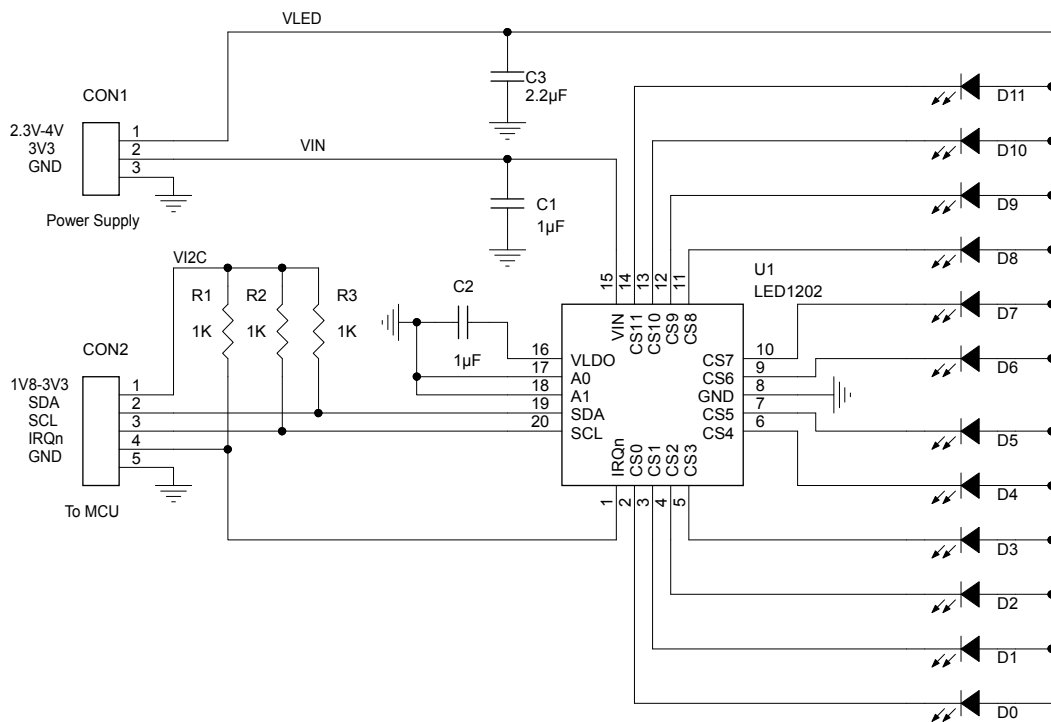

6.1.1 Component list

The following table provides the list of the minimum components required to run the application.

Table 6. Typical component list

Component name	Value	Unit	Comments
C1	1	μF	Input capacitor, rated voltage 6.3 V
C2	1	μF	LDO output capacitor, rated voltage 6.3 V
C3	2.2	μF	VLED filter capacitor, rated voltage 6.3 V
R1-R2-R3	1	KΩ	I ² C bus and IRQn pull-up resistors (for VI2C = 1.8 V)
D0-D11	LED		Load LEDs
U1	LED1202		12 channels LED driver

6.2 Cascading multiple devices

It is possible to connect multiple LED1202 devices in a cascade or matrix. Each device in the cascade needs to have a separately controlled local register area for full independent functionality. It is possible to define up to eight different I²C addresses with only two pins. The whole interface (SDA, SCL, IRQn) is connected in parallel.

Figure 21. Multiple device connection concept

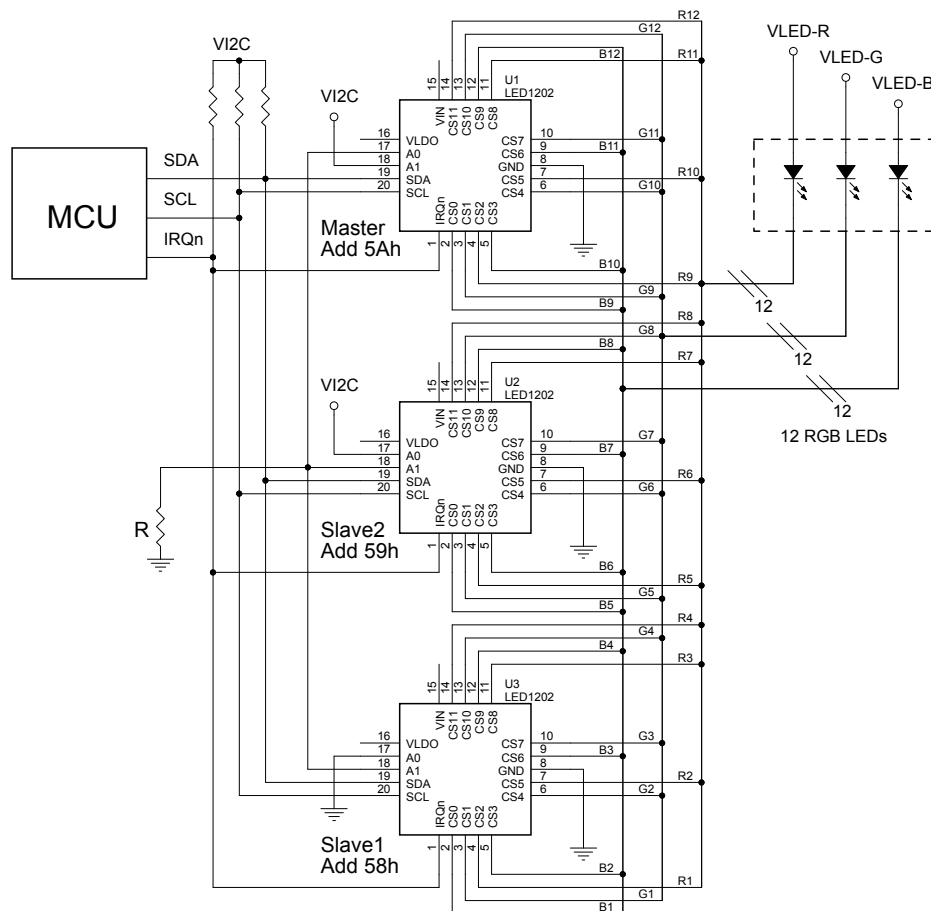

If the application allows the same configuration and patterns to be used, and does not need any register read, the number of devices is no longer limited by different I²C address (it depends only on I²C bus capability) because by using the global address all devices can be set in the same way with a unique writing I²C command.

If an application with multiple devices has to run a synchronous pattern sequence, a common clock domain configuration is needed. [Figure 21. Multiple device connection concept](#) shows a conceptual connection of a case with three devices (for an RGB application) using a common clock domain in star configuration.

A0 (clock out) of the LED1202-Red (that is the master of the clock domain) is connected with all the A1 (clock in) of slaves; the resistor R (for example 1.2 kΩ) to ground is needed to define the I²C address of the devices.

“Clock Configuration” register at address E0h has to be set to 02h for master (CLK_O_En = 1) and to 01h for all the slaves (CLK_I_En = 1). It is important to apply the above-mentioned setting before enabling the devices (EN = 1), this is to be sure that each device latches its own I²C address before that clock runs on A0 and A1 pins. Moreover, by using the global address to set EN = 1, all the devices start synchronized immediately using the common clock domain.

Figure 22. Command sequence example for star common clock domain configuration

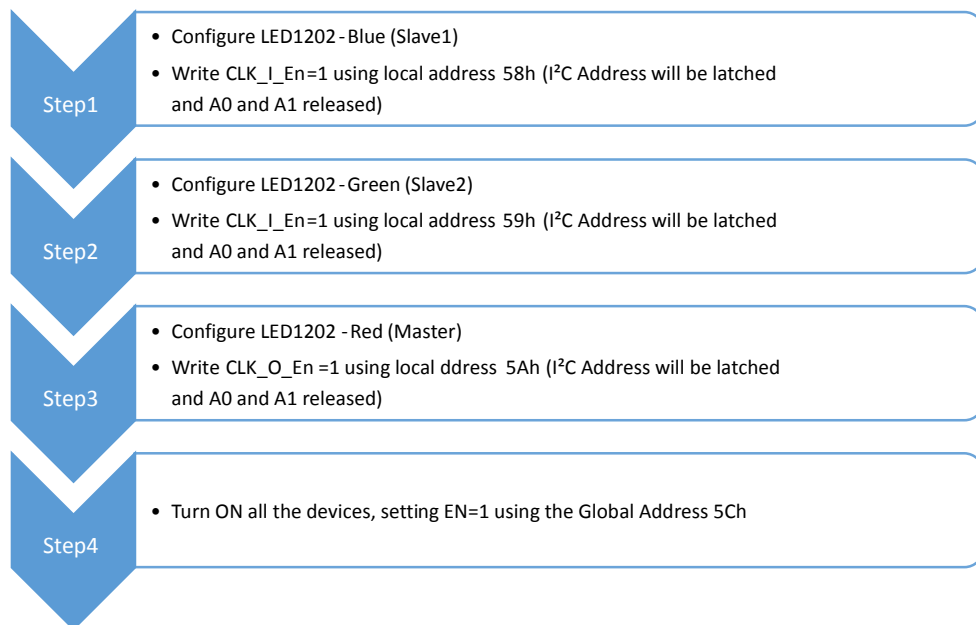

In case of common clock domain configured in daisy chain, master has to be set like before (CLK_O_En=1 and CLK_I_En=0), while the slaves need to accept clock but also to cascade it. So they have to be configured with CLK_O_En=1 and CLK_I_En=1 (value 03h in register E0h); except the last device in the chain that has not to output the clock, so it must be set as CLK_O_En=0 and CLK_I_En=1.

We have to note that in daisy chain configuration each connection A0-A1 has to be independent, so it is necessary to have a dedicated pull-up or pull-down resistor per link.

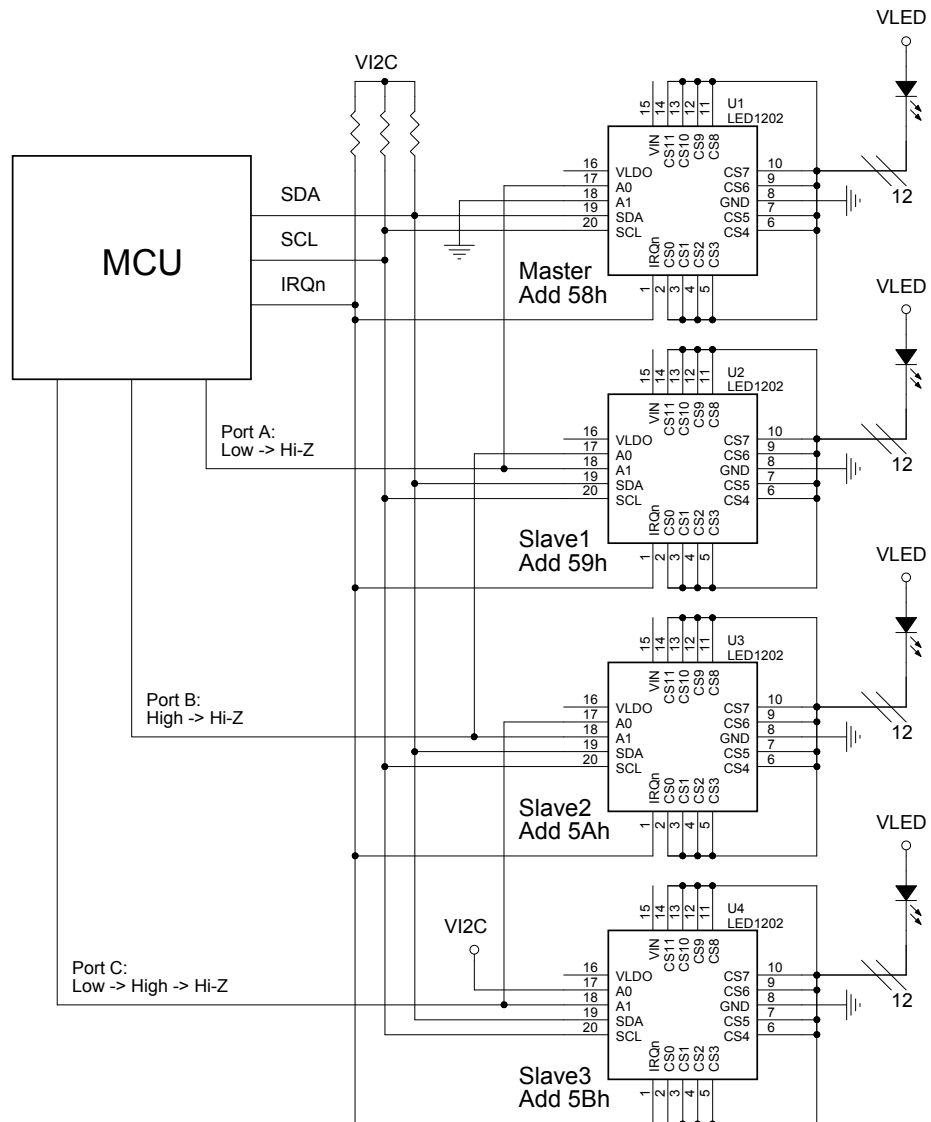
Figure 23. Concept of daisy chain common clock domain configuration

If pins A0 and A1 of two different devices, connected by a clock link, cannot have the same defined level to set the appropriate I²C address, the use of a simple resistor is no longer possible. In this case, it is possible to use GPIOs from an MCU (see [Figure 23. Concept of daisy chain common clock domain configuration](#)) to define dynamically the appropriate level, high or low, to set the I²C address of each device. After the 1st communication, MCU GPIOs must be put in Hi-Z to allow the clock transfer. Please, refer to [Figure 24. Command sequence example for daisy chain common clock domain configuration](#) as the right implementation of this concept.

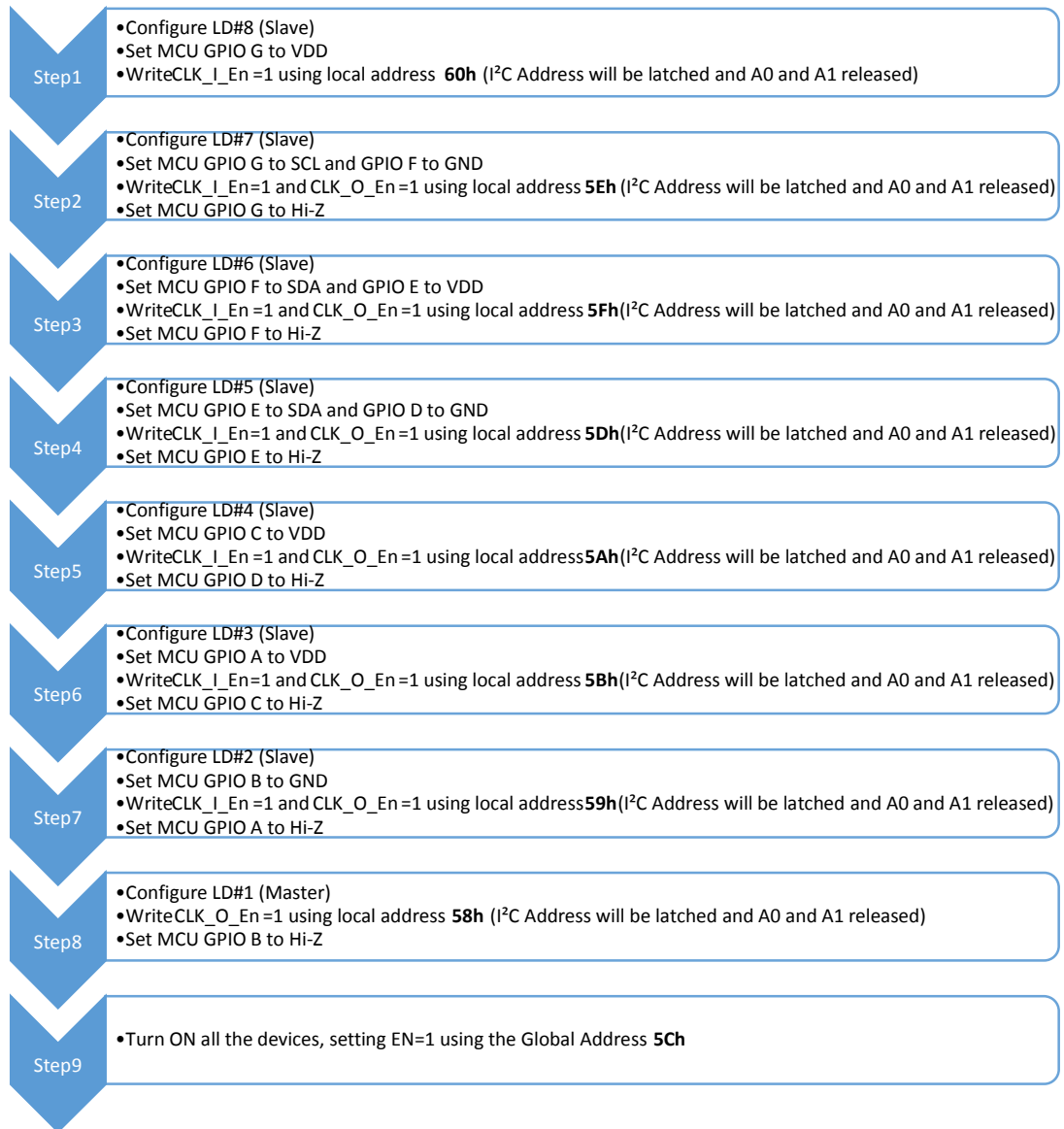
Figure 24. Command sequence example for daisy chain common clock domain configuration

It is a good rule to configure clock configuration register starting from the slaves and ending with master, in any case this must be done with all the devices disabled (EN=0).

7 Register description

The LED1202 can be monitored and controlled using the I²C communication interface.

Two different slave address types are available:

- Global address 5Ch (7-bit)
- Local address 58h to 5Bh and 5D to 60h (7-bit)

Global slave address is always available and fixed independently of A0 and A1 connection, it is used to control all the devices on the same I²C bus with a single writing. Local address, defined by A0 and A1 connection, allows each device to be controlled individually. Reading is possible using local address only.

The following table shows the registers map.

Table 7. Register map

Add	Name	POR value	B[7]	B[6]	B[5]	B[4]	B[3]	B[2]	B[1]	B[0]
00h	Device ID	12h	PROD_ID				REV_ID			
01h	Device Enable	00h	RST							EN
02h	Channel Enable Low	FFh	CS7	CS6	CS5	CS4	CS3	CS2	CS1	CS0
03h	Channel Enable High	0Fh					CS11	CS10	CS9	CS8
04h	Configuration	00h	PATS	PATSR	AUTODIS	GCTRL	SHFT	PATSEL		
05h	Fault and Status Mask	0Bh					SOF_M	PAT_M	OPEN_M	OVTP_M
06h	Fault and Status Interrupt	00h					SOF	PAT	OPEN	OVTP
07h	Open LED Low	00h	O_CS7	O_CS6	O_CS5	O_CS4	O_CS3	O_CS2	O_CS1	O_CS0
08h	Open LED High	00h					O_CS11	O_CS10	O_CS9	O_CS8
09h	CS0 LED Current	27h	ILED0							
0Ah	CS1 LED Current	27h	ILED1							
0Bh	CS2 LED Current	27h	ILED2							
0Ch	CS3 LED Current	27h	ILED3							
0Dh	CS4 LED Current	27h	ILED4							
0Eh	CS5 LED Current	27h	ILED5							
0Fh	CS6 LED Current	27h	ILED6							
10h	CS7 LED Current	27h	ILED7							
11h	CS8 LED Current	27h	ILED8							
12h	CS9 LED Current	27h	ILED9							
13h	CS10 LED Current	27h	ILED10							
14h	CS11 LED Current	27h	ILED11							
15h	Pattern Sequence Repetition	01h	PAT_REP							
16h	Pattern 0 Duration	1Fh	PAT0_DUR							
17h	Pattern 1 Duration	1Fh	PAT1_DUR							
18h	Pattern 2 Duration	1Fh	PAT2_DUR							
19h	Pattern 3 Duration	1Fh	PAT3_DUR							
1Ah	Pattern 4 Duration	1Fh	PAT4_DUR							

Add	Name	POR value	B[7]	B[6]	B[5]	B[4]	B[3]	B[2]	B[1]	B[0]
1Bh	Pattern 5 Duration	1Fh	PAT5_DUR							
1Ch	Pattern 6 Duration	1Fh	PAT6_DUR							
1Dh	Pattern 7 Duration	1Fh	PAT7_DUR							
Address offset 1Eh										
00h	Pattern0CS0 PWM Low	55h	PWM0_0_L							
01h	Pattern0CS0 PWM High	05h	PWM0_0_H							
02h	Pattern0CS1 PWM Low	55h	PWM1_0_L							
03h	Pattern0CS1 PWM High	05h	PWM1_0_H							
04h	Pattern0CS2 PWM Low	55h	PWM2_0_L							
05h	Pattern0CS2 PWM High	05h	PWM2_0_H							
06h	Pattern0CS3 PWM Low	55h	PWM3_0_L							
07h	Pattern0CS3 PWM High	05h	PWM3_0_H							
08h	Pattern0CS4 PWM Low	55h	PWM4_0_L							
09h	Pattern0CS4 PWM High	05h	PWM4_0_H							
0Ah	Pattern0CS5 PWM Low	55h	PWM5_0_L							
0Bh	Pattern0CS5 PWM High	05h	PWM5_0_H							
0Ch	Pattern0CS6 PWM Low	55h	PWM6_0_L							
0Dh	Pattern0CS6 PWM High	05h	PWM6_0_H							
0Eh	Pattern0CS7 PWM Low	55h	PWM7_0_L							
0Fh	Pattern0CS7 PWM High	05h	PWM7_0_H							
10h	Pattern0CS8 PWM Low	55h	PWM8_0_L							
11h	Pattern0CS8 PWM High	05h	PWM8_0_H							
12h	Pattern0CS9 PWM Low	55h	PWM9_0_L							
13h	Pattern0CS9 PWM High	05h	PWM9_0_H							
14h	Pattern0CS10 PWM Low	55h	PWM10_0_L							
15h	Pattern0CS10 PWM High	05h	PWM10_0_H							
16h	Pattern0CS11 PWM Low	55h	PWM11_0_L							
17h	Pattern0CS11 PWM High	05h	PWM11_0_H							
Address offset 36h										
00h	Pattern1CS0 PWM Low	FFh	PWM0_1_L							
01h	Pattern1CS0 PWM High	0Fh	PWM0_1_H							
...							
16h	Pattern1CS11 PWM Low	FFh	PWM11_1_L							
17h	Pattern1CS11 PWM High	0Fh	PWM11_1_H							
Address offset 4Eh										
00h	Pattern2CS0 PWM Low	FFh	PWM0_2_L							
01h	Pattern2CS0 PWM High	0Fh	PWM0_2_H							
...							
16h	Pattern2CS11 PWM Low	FFh	PWM11_2_L							
17h	Pattern2CS11 PWM High	0Fh	PWM11_2_H							

Add	Name	POR value	B[7]	B[6]	B[5]	B[4]	B[3]	B[2]	B[1]	B[0]	
Address offset 66h											
00h	Pattern3CS0 PWM Low	FFh	PWM0_3_L								
01h	Pattern3CS0 PWM High	0Fh								PWM0_3_H	
...								
16h	Pattern3CS11 PWM Low	FFh	PWM11_3_L								
17h	Pattern3CS11 PWM High	0Fh								PWM11_3_H	
Address offset 7Eh											
00h	Pattern4CS0 PWM Low	FFh	PWM0_4_L								
01h	Pattern4CS0 PWM High	0Fh								PWM0_4_H	
...								
16h	Pattern4CS11 PWM Low	FFh	PWM11_4_L								
17h	Pattern4CS11 PWM High	0Fh								PWM11_4_H	
Address offset 96h											
00h	Pattern5CS0 PWM Low	FFh	PWM0_5_L								
01h	Pattern5CS0 PWM High	0Fh								PWM0_5_H	
...								
16h	Pattern5CS11 PWM Low	FFh	PWM11_5_L								
17h	Pattern5CS11 PWM High	0Fh								PWM11_5_H	
Address offset AEh											
00h	Pattern6CS0 PWM Low	FFh	PWM0_6_L								
01h	Pattern6CS0 PWM High	0Fh								PWM0_6_H	
...								
16h	Pattern6CS11 PWM Low	FFh	PWM11_6_L								
17h	Pattern6CS11 PWM High	0Fh								PWM11_6_H	
Address offset C6h											
00h	Pattern7CS0 PWM Low	FFh	PWM0_7_L								
01h	Pattern7CS0 PWM High	0Fh								PWM0_7_H	
...								
16h	Pattern7CS11 PWM Low	FFh	PWM11_7_L								
17h	Pattern7CS11 PWM High	0Fh								PWM11_7_H	
Address offset 00h											
E0h	Clock Configuration	00h							CLK_O_En	CLK_I_En	

7.1 Device ID register

Table 8. Device ID register format

	Bit 7	Bit 6	Bit5	Bit4	Bit 3	Bit 2	Bit1	Bit 0
Add = 00h	PROD_ID				REV_ID			
POR = 12h	0	0	0	1	0	0	1	0
Comments	R	R	R	R	R	R	R	R

REV_ID: Silicon release identification

- 02h: cut 1.1

PROD_ID: Product identification

- 01h: LED1202

7.2 Device enable register

Table 9. Device enable register format

	Bit 7	Bit 6	Bit5	Bit4	Bit 3	Bit 2	Bit1	Bit 0
Add = 01h	RST	-	-	-	-	-	-	EN
POR = 00h	0	0	0	0	0	0	0	0
Comments	R/W	R	R	R	R	R	R	R/W

EN: Enable device

- 0: device is disabled (default)
- 1: device is enabled

RST: Reset device

- 0: device is not reset (default)
- 1: device is reset to default values

7.3 Channel enable registers

Table 10. Channel enable low register format

	Bit 7	Bit 6	Bit5	Bit4	Bit 3	Bit 2	Bit1	Bit 0
Add = 02h	EN_CS7	EN_CS6	EN_CS5	EN_CS4	EN_CS3	EN_CS2	EN_CS1	EN_CS0
POR = FFh	1	1	1	1	1	1	1	1
Comments	R/W	R/W	R/W	R/W	R/W	R/W	R/W	R/W

Table 11. Channel enable high register format

	Bit 7	Bit 6	Bit5	Bit4	Bit 3	Bit 2	Bit1	Bit 0
Add = 03h	-	-	-	-	EN_CS11	EN_CS10	EN_CS9	EN_CS8
POR = 0Fh	0	0	0	0	1	1	1	1
Comments	R	R	R	R	R/W	R/W	R/W	R/W

EN_CS0: LED channel 0 enable

- 0: channel is disabled
- 1: channel is enabled (default)

EN_CS11: LED channel 11 enable

- 0: channel is disabled
- 1: channel is enabled (default)

7.4 Configuration register

Table 12. Configuration register format

	Bit 7	Bit 6	Bit5	Bit4	Bit 3	Bit 2	Bit1	Bit 0
Add = 04h	PATS	PATSR	AUTODIS	GCTRL	SHFT	PATSEL		
POR = 00h	0	0	0	0	0	0	0	0
Comments	R/W	R/W	R/W	R/W	R/W	R/W	R/W	R/W

PATSEL: Pattern selection

- 000: pattern 0 is selected (default)
- 001: pattern 1 is selected
- ...
- 111: pattern 7 is selected

SHFT: Phase-shift feature

- 0: feature is disabled (default)
- 1: feature is enabled

AUTODIS: Auto disable device at the end of patterns sequence

- - 0: Auto disable off
- - 1: Auto disable on

Note: If **AUTODIS=1**, after the pattern repetition it is necessary to re-enable the device (by writing **EN=1** in the enable register 01h). This setting guarantees the running of internal system clock mandatory to read the status registers.

GCTRL: Group control

- 0: feature is disabled (default)
- 1: feature is enabled, PatternyCS0 PWM Low/High (y selected by PATSEL[2:0]) is used for all channels (can be used for backlight where each LED uses the same dimming)

PATSR: Pattern sequence runs (self-clear when sequence is finished)

- 0: pattern sequence is finished (default)
- 1: pattern sequence is run

PATS: Pattern sequence feature enable

- 0: pattern sequence feature is disabled (default)
- 1: pattern sequence feature is enabled; all outputs OFF when sequence does not run

7.5 Fault and status mask register

Table 13. Fault and status mask register format

	Bit 7	Bit 6	Bit5	Bit4	Bit 3	Bit 2	Bit1	Bit 0
Add = 05h	-	-	-	-	SOF_M	PAT_M	OPEN_M	OVTP_M
POR = 0Bh	0	0	0	0	1	0	1	1
Comments	R	R	R	R	R/W	R/W	R/W	R/W

OVTP_M: Chip overtemperature protection interrupt mask bit

- 0: interrupt not masked
- 1: interrupt masked

OPEN_M: Open LED detection on CS0-CS11 interrupt mask bit

- 0: interrupt not masked
- 1: interrupt masked

PAT_M: Pattern sequence finished interrupt mask bit

- 0: interrupt not masked
- 1: interrupt masked

SOF_M: Start of PWM frame interrupt mask bit

- 0: interrupt not masked
- 1: interrupt masked

7.6 Fault and status interrupt register

Table 14. Fault and status interrupt register format

	Bit 7	Bit 6	Bit5	Bit4	Bit 3	Bit 2	Bit1	Bit 0
Add = 06h	-	-	-	-	SOF	PAT	OPEN	OVTP
POR = 00h	0	0	0	0	0	0	0	0
Comments	R	R	R	R	R	R	R	R

OVTP: Chip overtemperature protection reached

0: OVTP not occurred

1: OVTP occurred

OPEN: Open LED detection on CS0-CS11

0: Open led on CSx not occurred

1: Open led on CSx occurred

PAT: Pattern sequence finished

0: Pattern sequence not finished

1: Pattern sequence finished

SOF: Start of PWM frame interrupt flag

0: PWM frame not started

1: PWM frame started

7.7 Open LED registers

Table 15. Open LED low register format

	Bit 7	Bit 6	Bit5	Bit4	Bit 3	Bit 2	Bit1	Bit 0
Add = 07h	O_CS7	O_CS6	O_CS5	O_CS4	O_CS3	O_CS2	O_CS1	O_CS0
POR = 00h	0	0	0	0	0	0	0	0
Comments	R	R	R	R	R	R	R	R

Table 16. Open LED high register format

	Bit 7	Bit 6	Bit5	Bit4	Bit 3	Bit 2	Bit1	Bit 0
Add = 08h	-	-	-	-	O_CS11	O_CS10	O_CS9	O_CS8
POR = 00h	0	0	0	0	0	0	0	0
Comments	R	R	R	R	R	R	R	R

If respective bit is set:

CS0: channel 0 is open

...

CS11: channel 11 is open

7.8 LED current registers

Table 17. CSx LED current register format

	Bit 7	Bit 6	Bit 5	Bit 4	Bit 3	Bit 2	Bit 1	Bit 0
Add = ADD ⁽¹⁾	ILEDx							
POR = 27h	0	0	1	0	0	1	1	1
Comments	R/W	R/W	R/W	R/W	R/W	R/W	R/W	R/W

1. ADD = 09h + xh, where x is the channel number in hexadecimal (x = 00h .. 0Bh)

ILEDx: Channel x LED current selection

$$I_{CS_SET} = ILEDx_value / 255 * 20 \text{ mA}$$

- LSB: 20 mA / 255 (step size)
- Range: 1 mA to 20 mA (3.06 mA as default)

Note: Registers value from 00h to 0Dh are functional, but the ILED provided is not guaranteed to be monotonic and accurate. 00h does not switch OFF the channel; it provides a minimal uncontrolled current because of some internal offsets.

7.9 Pattern sequence repetition register

Table 18. Pattern sequence repetition number register format

	Bit 7	Bit 6	Bit5	Bit4	Bit 3	Bit 2	Bit1	Bit 0
Add = 15h	PAT_REP							
POR = 01h	0	0	0	0	0	0	0	1
Comments	R/W	R/W	R/W	R/W	R/W	R/W	R/W	R/W

PAT_REP: Pattern sequence repetition number selection

- LSB: 1 time
- Range: 1 time to 254 times (not allowed to write PAT_REP=00h)
- Infinite loop: PAT_REP = FFh

7.10 Pattern duration registers

Table 19. Pattern y duration time register format

	Bit 7	Bit 6	Bit 5	Bit 4	Bit 3	Bit 2	Bit 1	Bit 0
Add = ADD ⁽¹⁾	PATy_DUR							
POR = 1Fh	0	0	0	1	1	1	1	1
Comments	R/W	R/W	R/W	R/W	R/W	R/W	R/W	R/W

1. $ADD = 16h + yh$, where y is the pattern number in hexadecimal ($y = 00h .. 07h$)

PATy_DUR: Pattern y duration time selection

- LSB: 22.2 ms
- Range: 22.2 ms to 5660 ms (690 ms as default)
- Pattern skip: PATy_DUR = 00h

7.11 Pattern PWM configuration registers

Table 20. Pattern0CSx PWM low register format

	Bit 7	Bit 6	Bit5	Bit4	Bit 3	Bit 2	Bit1	Bit 0
Add = ADDL ⁽¹⁾	PWMx_0_L							
POR = 55h	0	1	0	1	0	1	0	1
Comments	R/W	R/W	R/W	R/W	R/W	R/W	R/W	R/W

1. $ADDL = 1Eh + 2*(xh)$, where x is the channel number in hexadecimal ($x = 00h .. 0Bh$)

Table 21. Pattern0CSx PWM high register format

	Bit 7	Bit 6	Bit5	Bit4	Bit 3	Bit 2	Bit1	Bit 0
Add = ADDH ⁽¹⁾	-	-	-	-	PWMx_0_H			
POR = 05h	0	0	0	0	0	1	0	1
Comments	R	R	R	R	R/W	R/W	R/W	R/W

1. $ADDH = 1Eh + 01h + 2(xh)$, where x is the channel number in hexadecimal ($x = 00h .. 0Bh$)

PWMx_0_L: represents low 8 bits of PWM duty cycle value

PWMx_0_H: represents high 4 bits of PWM duty cycle value

- LSB: 1/4095 (step size)
- Offset: 0

(555h as default; channel ON with PWM at 33%)

Table 22. PatternyCSx PWM low register format

	Bit 7	Bit 6	Bit5	Bit4	Bit 3	Bit 2	Bit1	Bit 0
Add = ADDL	PWMx_y_L							
POR = FFh ⁽¹⁾	1	1	1	1	1	1	1	1
Comments	R/W	R/W	R/W	R/W	R/W	R/W	R/W	R/W

1. $ADDL = 1Eh + 2*(xh) + 18h*(yh)$, where x is the channel number in hexadecimal ($x = 00h .. 0Bh$) and y is the pattern number in hexadecimal ($y = 01h .. 07h$)

Table 23. PatternyCSx PWM high register format

	Bit 7	Bit 6	Bit5	Bit4	Bit 3	Bit 2	Bit1	Bit 0
Add = ADDH ⁽¹⁾	-	-	-	-	PWMx_y_H			
POR = 0Fh	0	0	0	0	1	1	1	1
Comments	R	R	R	R	R/W	R/W	R/W	R/W

1. $ADDH = 1Eh + 01h + 2(xh) + 18h*(yh)$, where x is the channel number in hexadecimal ($x = 00h .. 0Bh$) and y is the pattern number in hexadecimal ($y = 01h .. 07h$)

PWMx_y_L: represents low 8 bits of PWM duty cycle value

PWMx_y_H: represents high 4 bits of PWM duty cycle value

- LSB: 1/4095 (step size)
- Offset: 0

(FFh as default; channel ON with PWM at 100% = fully ON)

Table 24. PatternyCSx PWM low/high registers

CSx	Patterny							
	low/high register ADDRs (hex)							
	Default value (hex)							
	0	1	2	3	4	5	6	7
CS0	1E/1F	36/37	4E/4F	66/67	7E/7F	96/97	AE/AF	C6/C7
	555	FFF	FFF	FFF	FFF	FFF	FFF	FFF
CS1	20/21	38/39	50/51	68/69	80/81	98/99	B0/B1	C8/C9
	555	FFF	FFF	FFF	FFF	FFF	FFF	FFF
CS2	22/23	3A/3B	52/53	6A/6B	82/83	9A/9B	B2/B3	CA/CB
	555	FFF	FFF	FFF	FFF	FFF	FFF	FFF
CS3	24/25	3C/3D	54/55	6C/6D	84/85	9C/9D	B4/B5	CC/CD
	555	FFF	FFF	FFF	FFF	FFF	FFF	FFF
CS4	26/27	3E/3F	56/57	6E/6F	86/87	9E/9F	B6/B7	CE/CF
	555	FFF	FFF	FFF	FFF	FFF	FFF	FFF
CS5	28/29	40/41	58/59	70/71	88/89	A0/A1	B8/B9	D0/D1
	555	FFF	FFF	FFF	FFF	FFF	FFF	FFF
CS6	2A/2B	42/43	5A/5B	72/73	8A/8B	A2/A3	BA/BB	D2/D3
	555	FFF	FFF	FFF	FFF	FFF	FFF	FFF
CS7	2C/2D	44/45	5C/5D	74/75	8C/8D	A4/A5	BC/BD	D4/D5
	555	FFF	FFF	FFF	FFF	FFF	FFF	FFF
CS8	2E/2F	46/47	5E/5F	76/77	8E/8F	A6/A7	BE/BF	D6/D7
	555	FFF	FFF	FFF	FFF	FFF	FFF	FFF
CS9	30/31	48/49	60/61	78/79	90/91	A8/A9	C0/C1	D8/D9
	555	FFF	FFF	FFF	FFF	FFF	FFF	FFF
CS10	32/33	4A/4B	62/63	7A/7B	92/93	AA/AB	C2/C3	DA/DB
	555	FFF	FFF	FFF	FFF	FFF	FFF	FFF
CS11	34/35	4C/4D	64/65	7C/7D	94/95	AC/AD	C4/C5	DC/DD
	555	FFF	FFF	FFF	FFF	FFF	FFF	FFF

7.12 Clock configuration register

Table 25. Clock Configuration register format

	Bit 7	Bit 6	Bit5	Bit4	Bit 3	Bit 2	Bit1	Bit 0
Add = E0h	-	-	-	-	-	-	CLK_O_En	CLK_I_En
POR = 00h	0	0	0	0	0	0	0	0
Comments	R	R	R	R	R	R	R/W	R/W

CLK_O_En: Enable internal clock output to A0

0: Disable

1: Enable

CLK_I_En: Enable external clock input to A1

0: Disable

1: Enable

Note: After first ACK, device latches the I²C address freeing A0 and A1 for different use

8 Package information

In order to meet environmental requirements, ST offers these devices in different grades of **ECOPACK®** packages, depending on their level of environmental compliance. ECOPACK® specifications, grade definitions and product status are available at: www.st.com. ECOPACK® is an ST trademark.

8.1 WLCSP20 (1.71 x 2.16 x 0.5 mm) package information

The LED1202JR is in Wafer Level Chip Scale Package (WLCSP).

Figure 25. WLCSP20 (1.71 x 2.16 x 0.5 mm) package outline

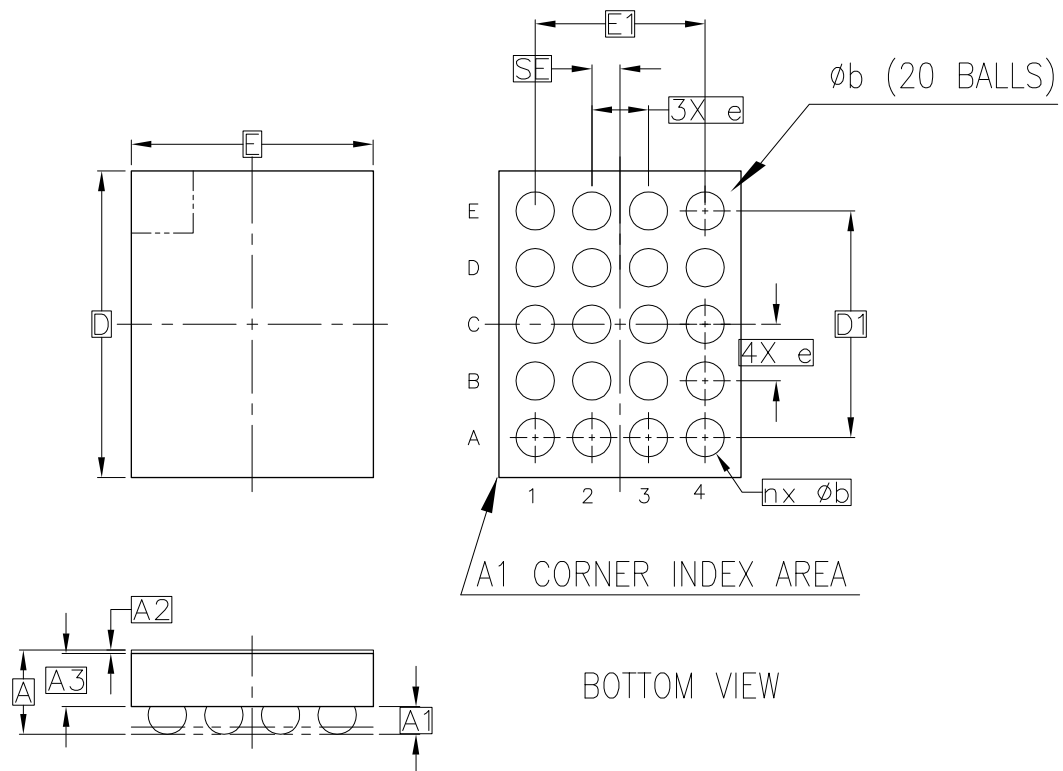
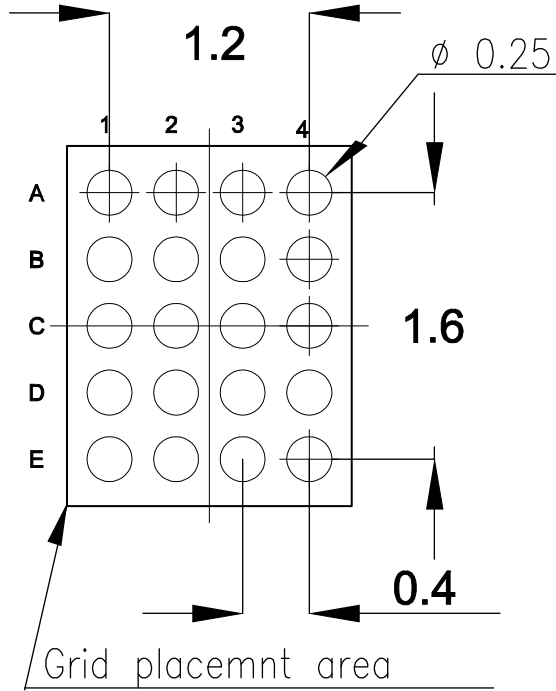

Table 26. WLCSP20 (1.71 x 2.16 x 0.5 mm) package mechanical data

Dim.	mm		
	Min.	Typ.	Max.
A	0.537	0.595	0.653
A1	0.165		0.225
A2	0.022	0.025	0.028
A3	0.285	0.300	0.315
E	1.689	1.709	1.729
D	2.144	2.164	2,184
SE	0.2 BSC		
E1	1.2 BSC		
D1	1.6 BSC		
e		0.4	
b	0.21	0.24	0.27

Figure 26. WLCSP20 (1.71 x 2.16 x 0.5 mm) recommended footprint

8.2 QFN20 3x3 package information

The LED1202QTR is in Quad Flat No-lead (QFN) package.

Figure 27. QFN20 3x3 (3 x 3 x 0.6 mm 20 L with 0.5 mm pitch) package outline

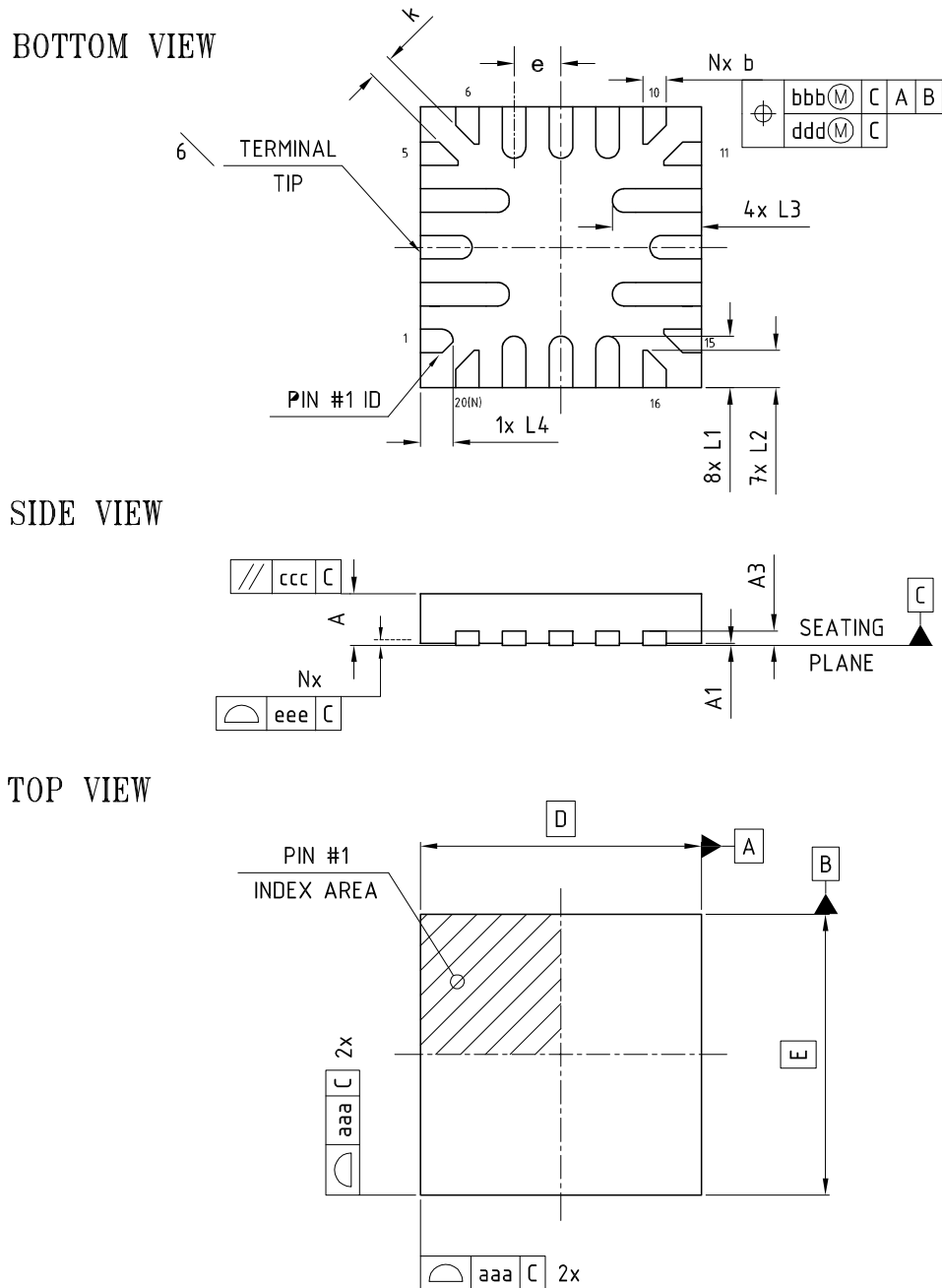
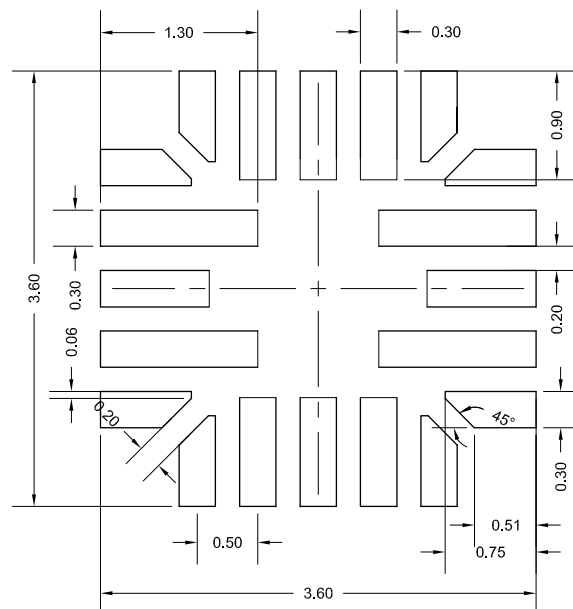

Table 27. QFN20 3x3 (3 x 3 x 0.6 mm 20 L with 0.5 mm pitch) package mechanical data

Dim.	mm		
	Min.	Typ.	Max.
A	0.50	0.55	0.60
A1	0.00	0.02	0.05
A3		0.153 Ref.	
b	0.18	0.25	0.30
D		3.00 BSC	
E		3.00 BSC	
e		0.50 BSC	
L1	0.45	0.55	0.65
L2	0.30	0.40	0.50
L3	0.85	0.95	1.05
L4	0.25	0.35	0.45
k		0.25 Ref.	
N		20	

Figure 28. QFN20 3x3 (3 x 3 x 0.6 mm 20 L with 0.5 mm pitch) recommended footprint

9 Ordering information

Table 28. Ordering information

Order code	Package	Packing
LED1202QTR	QFN20 3x3	Tape and reel
LED1202JR	WLCSP20	

Revision history

Table 29. Document revision history

Date	Revision	Changes
31-Jan-2019	1	First release.
14-Feb-2019	2	Updated package figure on the cover page.

Contents

1	Introduction	2
1.1	Block diagram	2
2	Pinout and pin description	3
2.1	WLCSP20 package - ball assignment	3
2.2	QFN20 3x3 package - pin assignment	3
2.3	Pin description	3
3	Electrical characteristics	5
3.1	Maximum ratings	5
3.2	Thermal information	5
3.3	LED1202 electrical characteristics	6
3.4	Headroom voltage	8
4	Device description	9
4.1	Device startup	9
4.2	Device reset	9
4.3	Device address selection	9
4.4	LED channel selection	9
4.5	Output dimming modes	10
4.5.1	LED controlled by “CSx LED Current” registers (analog dimming)	10
4.5.2	LED controlled by “PatternyCSx PWM” registers (digital dimming)	10
4.5.3	LED controlled by “CSx LED Current” and “PatternyCSx PWM” registers	11
4.6	Phase-shift	11
4.7	Pattern selection and configuration	12
4.8	Pattern sequence configuration	12
4.9	Device synchronization	13
4.9.1	Common clock domain configuration	13
4.10	Alarms and IRQ generation	13
4.10.1	Open LED interrupt	14
4.10.2	Overtemperature protection (OVTP) interrupt	14
4.10.3	Pattern end interrupt	14

4.10.4	Start of frame interrupt	14
5	Device interface	16
5.1	IRQn output pin	16
5.2	I ² C bus interface	16
5.2.1	The LED1202 addressing	16
5.2.2	Data validity	16
5.2.3	Start and stop conditions	17
5.2.4	Byte format	17
5.2.5	Acknowledge	17
5.2.6	Interface protocol	18
5.2.7	Writing to a single register	18
5.2.8	Writing to multiple registers with incremental addressing	19
5.2.9	Reading from a single register	19
5.2.10	Reading from multiple registers with incremental addressing	20
6	Application hints	21
6.1	Schematic diagram	21
6.1.1	Component list	22
6.2	Cascading multiple devices	22
7	Register description	26
7.1	Device ID register	29
7.2	Device enable register	30
7.3	Channel enable registers	31
7.4	Configuration register	32
7.5	Fault and status mask register	33
7.6	Fault and status interrupt register	34
7.7	Open LED registers	35
7.8	LED current registers	36
7.9	Pattern sequence repetition register	37
7.10	Pattern duration registers	38
7.11	Pattern PWM configuration registers	39
7.12	Clock configuration register	41

8	Package information	42
8.1	WLCSP20 (1.71 x 2.16 x 0.5 mm) 20 package information.....	43
8.2	VFQFPN (3 x 3 x 0.6 mm 20 L) package information.....	45
9	Ordering information	47
	Revision history	48

List of tables

Table 1.	Pin description	4
Table 2.	Absolute maximum ratings	5
Table 3.	Thermal data	5
Table 4.	LED1202 electrical characteristics $V_{IN} = 3.3\text{ V}$, SDA, SCL and IRQn = 1.8 V, $T_a = 25\text{ }^\circ\text{C}$, RC load = 50 Ω /10 pF, unless otherwise specified.	6
Table 5.	LED1202 local address table	9
Table 6.	Typical component list	22
Table 7.	Register map	26
Table 8.	Device ID register format	29
Table 9.	Device enable register format	30
Table 10.	Channel enable low register format	31
Table 11.	Channel enable high register format	31
Table 12.	Configuration register format	32
Table 13.	Fault and status mask register format	33
Table 14.	Fault and status interrupt register format	34
Table 15.	Open LED low register format	35
Table 16.	Open LED high register format	35
Table 17.	CSx LED current register format	36
Table 18.	Pattern sequence repetition number register format	37
Table 19.	Pattern y duration time register format	38
Table 20.	Pattern0CSx PWM low register format	39
Table 21.	Pattern0CSx PWM high register format	39
Table 22.	PatternyCSx PWM low register format	39
Table 23.	PatternyCSx PWM high register format	39
Table 24.	PatternyCSx PWM low/high registers	40
Table 25.	Clock Configuration register format	41
Table 26.	WLCSP20 (1.71 x 2.16 x 0.5 mm) package mechanical data	43
Table 27.	QFN20 3x3 (3 x 3 x 0.6 mm 20 L with 0.5 mm pitch) package mechanical data	46
Table 28.	Ordering information.	47
Table 29.	Document revision history	48

List of figures

Figure 1.	LED1202 simplified block diagram	2
Figure 2.	LED1202JR ball assignment (top and marking side view)	3
Figure 3.	LED1202QTR pin assignment (top and marking side view).	3
Figure 4.	LED1202 headroom voltage vs. I_{LED}	8
Figure 5.	Analog dimming	10
Figure 6.	Digital dimming.	10
Figure 7.	Analog+digital dimming	11
Figure 8.	Phase-shift feature scheme	12
Figure 9.	SOF position in case of SHFT=1	15
Figure 10.	I ² C timing reference.	16
Figure 11.	Data validity on the I ² C Bus	17
Figure 12.	Start and stop condition on the I ² C Bus	17
Figure 13.	Bit transfer	17
Figure 14.	Acknowledge on the I ² C bus.	18
Figure 15.	Interface protocol	18
Figure 16.	Writing to a single register	19
Figure 17.	Writing to multiple registers	19
Figure 18.	Reading from a single register	20
Figure 19.	Reading from multiple registers.	20
Figure 20.	LED driver schematic diagram	21
Figure 21.	Multiple device connection concept	22
Figure 22.	Command sequence example for star common clock domain configuration	23
Figure 23.	Concept of daisy chain common clock domain configuration.	24
Figure 24.	Command sequence example for daisy chain common clock domain configuration	25
Figure 25.	WLCSP20 (1.71 x 2.16 x 0.5 mm) package outline	43
Figure 26.	WLCSP20 (1.71 x 2.16 x 0.5 mm) recommended footprint	44
Figure 27.	QFN20 3x3 (3 x 3 x 0.6 mm 20 L with 0.5 mm pitch) package outline.	45
Figure 28.	QFN20 3x3 (3 x 3 x 0.6 mm 20 L with 0.5 mm pitch) recommended footprint	46

IMPORTANT NOTICE – PLEASE READ CAREFULLY

STMicroelectronics NV and its subsidiaries (“ST”) reserve the right to make changes, corrections, enhancements, modifications, and improvements to ST products and/or to this document at any time without notice. Purchasers should obtain the latest relevant information on ST products before placing orders. ST products are sold pursuant to ST’s terms and conditions of sale in place at the time of order acknowledgement.

Purchasers are solely responsible for the choice, selection, and use of ST products and ST assumes no liability for application assistance or the design of Purchasers’ products.

No license, express or implied, to any intellectual property right is granted by ST herein.

Resale of ST products with provisions different from the information set forth herein shall void any warranty granted by ST for such product.

ST and the ST logo are trademarks of ST. All other product or service names are the property of their respective owners.

Information in this document supersedes and replaces information previously supplied in any prior versions of this document.

© 2019 STMicroelectronics – All rights reserved

Mouser Electronics

Authorized Distributor

Click to View Pricing, Inventory, Delivery & Lifecycle Information:

[STMicroelectronics:](#)

[LED1202JR](#) [LED1202QTR](#)