

DREMEL®

Operating/Safety Instructions Model 335 Plunge Router Attachment



- Safety
- Assembly
- Operation
- Service Parts
- Warranty

DREMEL® P.O. Box 1468
Racine, Wisconsin

1-800-437-3635
<http://www.dremel.com>

Dremel brand products are manufactured and sold by the
Dremel Division of Robert Bosch Tool Corporation

Power Tool Safety Rules



WARNING

Read and understand all instructions. Failure to follow all instructions listed below, may result in electric shock, fire and/or serious personal injury.

SAVE THESE INSTRUCTIONS

Make sure to read and understand the Owner's Manual for your Dremel Rotary Tool Models 275, 285, 395 & 398.

Safety Rules for Routers

Hold tool by insulated gripping surfaces when performing an operation where the cutting tool may contact hidden wiring or its own cord. Contact with a "live" wire will make exposed metal parts of the tool "live" and shock the operator. If cutting into existing walls or other blind areas where electrical wiring may exist is unavoidable, disconnect all fuses or circuit breakers feeding this worksite.

Always make sure the work surface is free from nails and other foreign objects. Cutting into a nail can cause the bit and the tool to jump and damage the bit.

Never hold the workpiece in one hand and the tool in the other hand when in use. Never place hands near or below cutting surface. Clamping the material and guiding the tool with both hands is safer.

Never place tool with bit protruding through base on top of bench or work surface. Lay the tool on its side or retract the bit before setting on bench or work surface. Protruding cutting bit may cause tool to jump.

Always wear safety goggles and dust mask. Use only in well ventilated area. Using personal safety devices and working in safe environment reduces risk of injury.

After changing the bits or making any adjustments, make sure the collet nut and any other adjustment devices are securely tightened. Loose adjustment device can unexpectedly shift, causing loss of control. Loose rotating components will be violently thrown.

Never start the tool when the bit is engaged in the material. The bit cutting edge may grab the material causing loss of control of the cutter.

Always hold the tool with two hands during startup. The reaction torque of the motor can cause the tool to twist.

The direction of feeding the bit into the material is very important and it relates to the direction of bit rotation. When viewing the tool from the top, the bit rotates clockwise. Feed direction of cutting must be counterclockwise. NOTE: Inside and outside cuts will require different feed direction. Refer to section on feeding the router. Feeding the tool in the wrong direction causes the cutting edge of the bit to climb out of the workpiece and pull the tool in the direction of the feed.

Always use the tool with the router base securely attached and positioned flat against material being cut. Having the base securely positioned on the material improves the stability and control of your tool.

Never use dull or damaged bits. Sharp bits must be handled with care. Damaged bits can snap during use. Dull bits require more force to push the tool, possibly causing the bit to break.

Never touch the bit during or immediately after use. After use, the bit is too hot to be touched by bare hands.

Never lay the tool down until the motor has come to complete stop. The spinning bit can grab the surface and pull the tool out of your control.

Do not use the tool for drilling purposes. This tool is not intended to be used with drill bits.

Never use bits that have a cutting diameter greater than the opening in the base.

Operating Controls

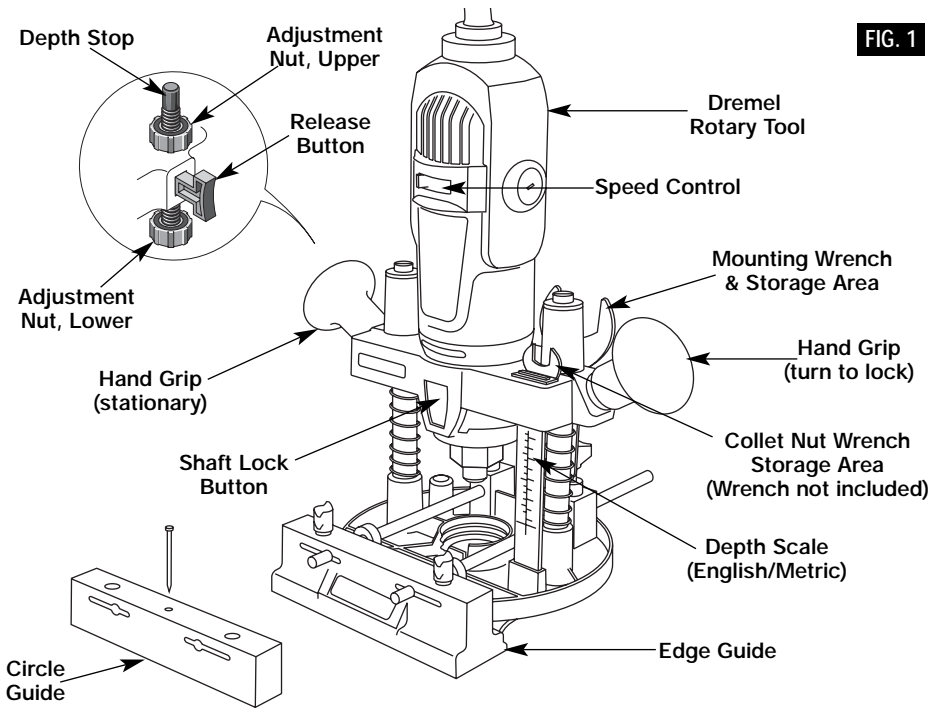

Assembling Plunge Router Attachment to your Tool

ATTACHMENT FOR USE WITH DREMEL ROTARY TOOL MODELS 275, 285, 395, & 398.

⚠ WARNING Disconnect the plug from the power source before making any assembly, adjustments or changing accessories. Such preventive safety measures reduce the risk of starting the tool accidentally.

1. Remove collet nut, then remove housing cap from your rotary tool and set housing cap aside (Fig. 2). The housing cap must be reinstalled when this attachment is not used. Once housing cap has been removed, reassemble the collet nut.



2. Place tool into your router attachment with the shaft lock button facing forward as shown (Fig. 3).
3. Thread mounting nut clockwise onto the threaded portion of your Rotary Tool and securely tighten with the mounting wrench provided.

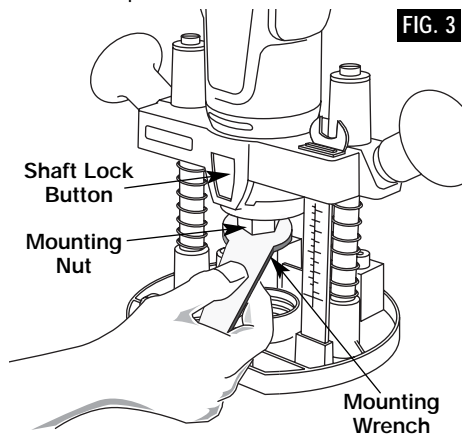

Operating Instructions

ATTACHMENT FOR USE WITH DREMEL HIGH SPEED ROTARY TOOL MODELS 275, 285, 395, & 398.

ATTENTION: This attachment will convert Dremel Rotary Tool to a Plunge Router for freehand routing, edging, grooving, and

circular cuts. The router attachment comes assembled ready for freehand or pilot bit routing.

⚠ WARNING This Router Attachment is not intended for use under a router or saw table.

Inserting the Router Bit

The router bits are held in the tool by a collet system. **The bit may be installed before or after the rotary tool is installed in the attachment.**

1. Depress and hold the shaft lock button while rotating the collet nut and shaft. Continue to rotate the collet nut and shaft until the lock engages and holds the shaft (Fig. 4).
2. Use the wrench from your Dremel Rotary Tool and turn the collet nut counter-clockwise to loosen it.
3. Release the shaft lock button.

4. Insert the router bit into the collet as deep as possible to ensure proper gripping of the bit and to minimize run out. Do not insert the bit so far that bit flutes touch the collet or collet nut to avoid chipping or cracking the bit.

NOTE: Never place the tool with bit protruding through base on top of bench or work surface. Lay the tool on its side or retract the bit before setting on bench or work surface. Protruding cutting bit may cause tool to jump.

5. Re-engage the shaft lock button and tighten the collet nut; first by hand, then using the wrench until bit is held securely.

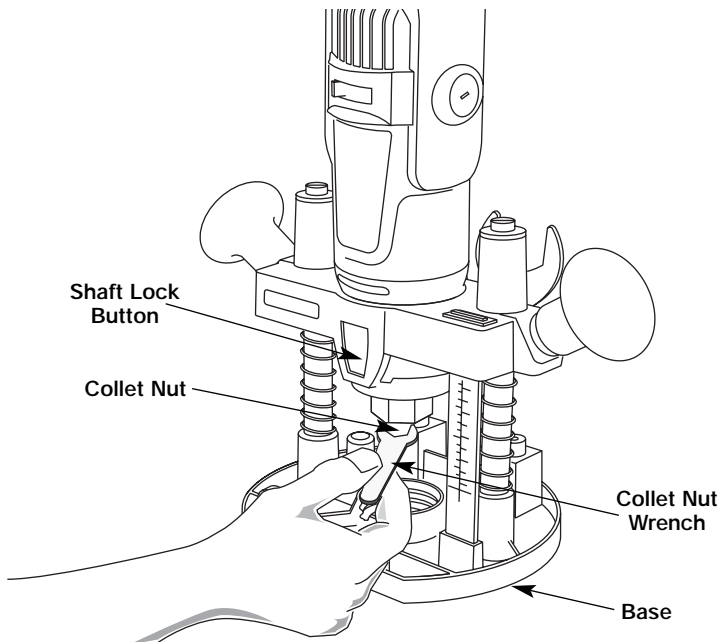

FIG. 4

Adjusting Routing Depth

NOTE: When making deep cuts, especially plunge cuts away from the edge of the workpiece, it is recommended to make several successive cuts progressively deeper using the depth adjustment and depth scale rather than making one single deep cut.

The depth limiter can be adjusted for two depths.

1. Place your Dremel Rotary Tool and Router assembly on the workpiece.
2. Turn the upper adjustment nut upward

and turn the lower adjustment nut downward so depth stop is free to move (Fig. 5).

FIG. 5

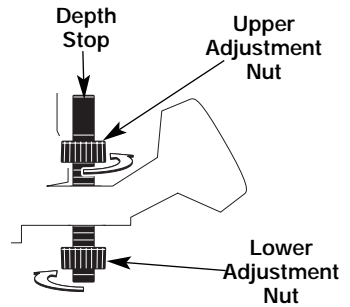

3. Loosen the locking hand grip (Fig. 6). Slowly lower the tool until the router bit just touches the workpiece.
4. Tighten the locking hand grip to lock the tool in place.
5. Press and hold the release button so depth stop touches the router base.

FIG. 6

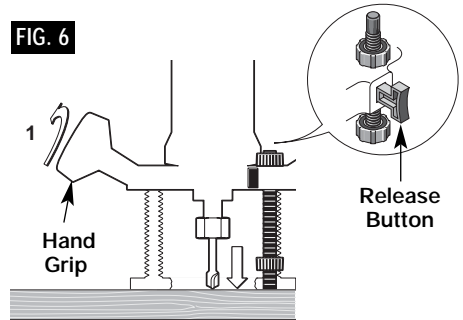

1st Routing Depth

6. Turn the depth stop upwards so that measurement X equals the first desired routing depth (Fig. 7).

NOTE: 1 turn equals .06" (1.5 mm)

7. Turn the upper adjustment nut down snug against the router frame.

FIG. 7

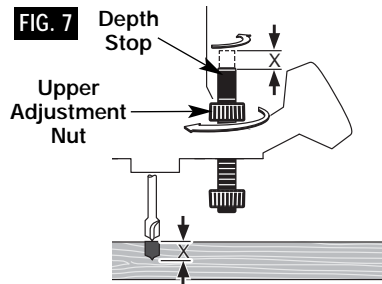

2nd Routing Depth

8. Turn the depth stop upwards so that measurement X equals the second desired routing depth. Make sure upper adjustment nut turns with the depth stop, so it rises away from router frame (Fig. 8).
9. Turn the lower adjustment nut up snug against the router frame.

NOTE: The upper adjustment nut must remain stationary when tightening the lower adjustment nut.

FIG. 8

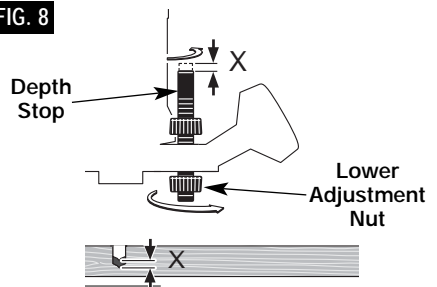

10. Press the release button to select the 1st or 2nd routing depth (Fig. 9).

NOTE: The adjustment of each routing depth should be checked with a trial cut and re-adjusted as necessary.

When routing is complete, loosen the hand grip and return the router to the top position.

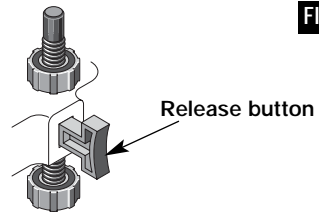

FIG. 9

Feeding the Router

If the router is hard to control, heats up, runs very slowly or leaves an imperfect cut, consider these causes:

- Wrong direction of feed – hard to control.
- Feeding too fast – overloads motor.
- Dull bit – overloads motor.

- Cut too large for one pass – overloads motor.
- Feeding too slow – leaves friction burns on the workpiece.

Feed smoothly and steadily (do not force). You will soon learn how the router sounds and feels when it is working best.

Rate Of Feed

When routing or doing related work in wood and plastics, the best finishes will result if the depth of cut and feed rate are regulated to keep the motor operating at high speed. Feed the router at a moderate rate. Soft materials require a faster feed rate than hard materials.

The router may stall if improperly used or overloaded. Reduce the feed rate to prevent possible damage to the tool. Always be sure the collet nut is tightened securely before use. Always use router bits with the shortest cutting length necessary to produce the desired cut. This will minimize router bit run-out and chatter.

Edge Forming

When edge forming, always use piloted or bearing bits. The lower portion of a pilot tipped bit is a shaft with no cutting edges. Bearing guide bits have a ball bearing to pilot the bit.

The pilot slides along the edge of the work as the rotating blades make the cut, making decorative edges. The edge on which the

pilot slides should be perfectly smooth since any irregularities are transferred to the shaped surface.

When routing a workpiece that requires edge forming on the endgrain, always rout the endgrain edge before routing the edges that follow the grain. This minimizes the possibility of damage from any blowout at the end of the endgrain.

Router Feed Direction

The router spindle turns in a clockwise direction when viewed from above. For best control and quality of cut, feed the tool into the workpiece in the direction that the bit will tend to pull itself into the wood. Incorrect feed direction will cause the bit to try and climb over the wood.

Feed the tool in direction shown here. If cutting around the edge of a square piece, move the tool in a counterclockwise direction. If routing the inside surface as shown, move in a clockwise direction (Fig. 10).

NOTE: Feed direction is extremely important when using a pilot bit freehand on the edge of a workpiece.

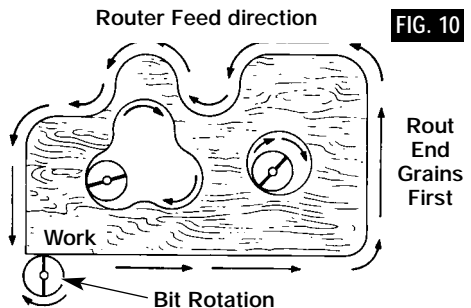

FIG. 10

Tool Lubrication

Periodic cleaning and lubrication of guide posts will keep plunge action smooth.

Depress and lock plunge router and evenly apply a light lubricant (i.e. petroleum jelly, cooking oil) to upper portion of guide posts.

Assembling the Edge Guide

For edge guide use, assemble guide rods into tool holder assembly and secure using (2) #10-24 square nuts and (2) guide rod knobs (Fig. 11).

Square nut will slide in slots above the guide rods. Guide rod knobs are assembled from the top through holes down through nuts, and against the rods. Fasten edge guide to guide rods using edge guide knobs, and hex head nuts.

Locate hex head nuts underneath edge guide and fasten with edge guide knob on top surface of edge guide. Slide edge guide

assembly on guide rods as shown. Set edge guide at desired distance from cutter and tighten edge guide knobs. (See Fig. 11)

Edge guide is used for shaping edges, cutting rabbets, dadoes, mortise, tongues, grooves, slots, and chamfers. Remember to feed so the cutter tends to pull the edge guide against the wood. A consistent feed rate gives a smooth cut.

In general, several shallow cuts should be used when a deep groove is desired. Maximum depth of cut will vary depending on material used. Do not over feed to an amount that the motor is noticeably slowed.

FIG. 11

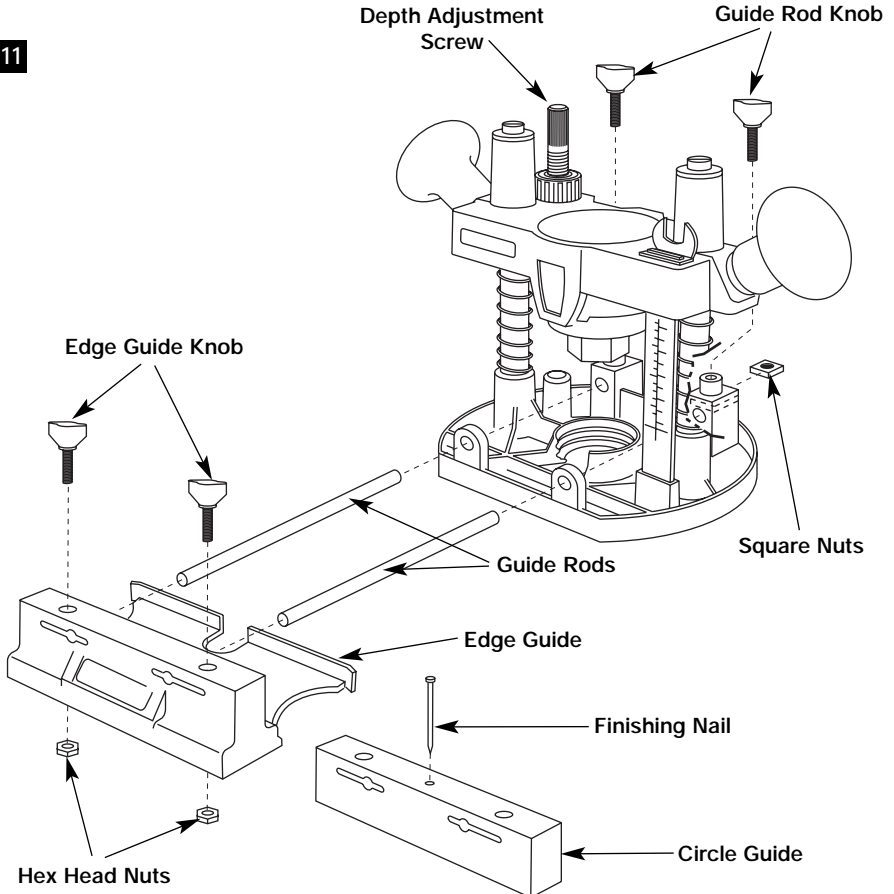

Edge Guide

Installation

1. Install the edge guide to the plunge router mounting blocks (Fig. 12).
2. Place parallel guide against work surface with router bit in desired position.
3. Tighten thumbscrews.

Routing with Edge Guide

Slide the flattened side of the edge guide along the work surface.

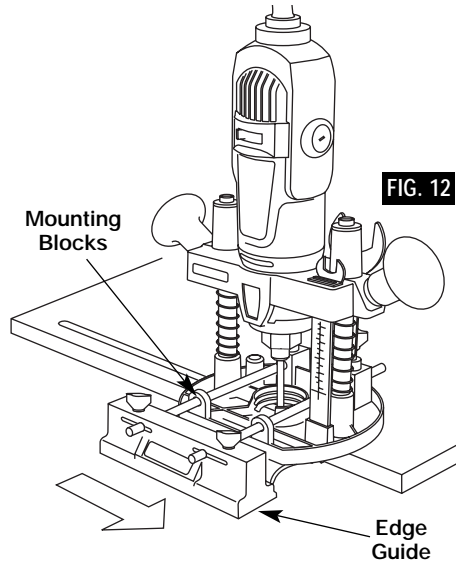
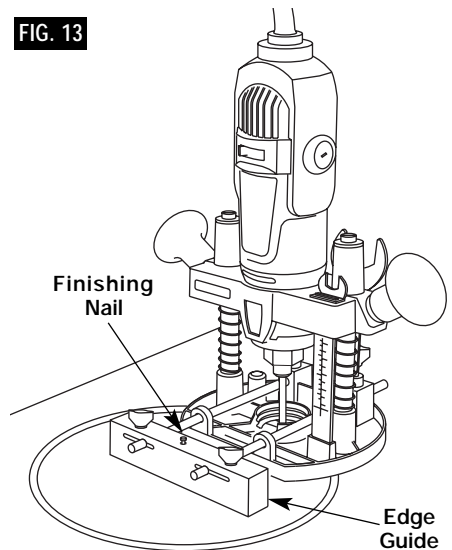

FIG. 13

Routing Arcs and Circles

1. Remove the edge guide and attach the circle guide bracket to the guide rods (Fig. 13).
2. Use the finishing nail provided as a compass point. Set the circle guide for the desired radius.
3. Place the nail through the hole in the guide and place the nail at the center of the desired radius to be cut.



Templates

Using template patterns lets you duplicate designs or letters uniformly time after time. This technique requires the use of a guide bushing.

GUIDE BUSHINGS

The guide bushing shown in (Fig. 14), is essentially a plate with a collar which is inserted into the hole in base as shown, and secured by threading a bushing plug on top of the guide bushing. The guide bushing rides along the edge of the template while the router bit, protruding below, cuts into the work.

FIG. 14

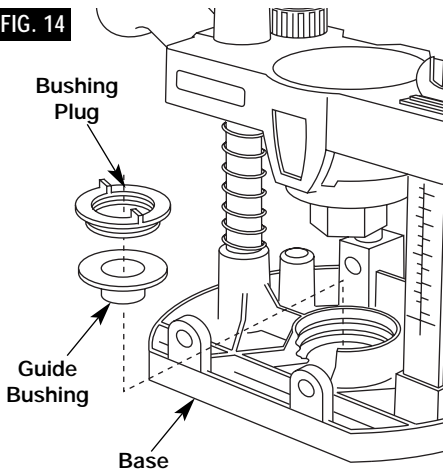

ATTENTION: Be sure the thickness of the template is the same or larger than the length of bushing protruding below the base.

Do not use a bit that may touch the inside of the collar. Select a bit that is at least 1/16" less in diameter.

In addition, special templates are easily prepared for cutting repeated patterns, special designs, inlays, and other applications. A template pattern may be made of plywood, hardboard, metal or even plastic, and the design can be cut with a router, jigsaw, or other suitable cutting tool.

Remember that the pattern will have to be made to compensate for the distance between the router bit and the guide bushing (the "offset"), as the final workpiece will differ in size from the template pattern by that amount, due to the bit position (Fig. 15).

FIG. 15

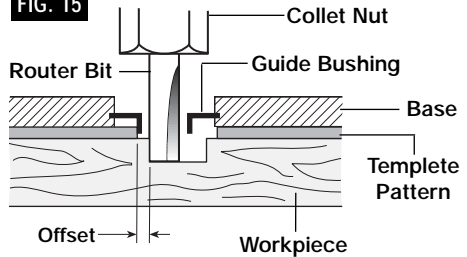

FREEHAND ROUTING

Many effects are gained by using the router freehand with a small diameter bit. Usually the craftsman pencils the outline or script he desires onto the work and uses the pencil line as a guide.

Dremel Parts Diagram

Ref. No.	Part No.	Description	Ref. No.	Part No.	Description
1	2610920042	Spring (2)	15	2610920043	Pressure Spindle
2	2610920041	Guide Post. (2)	16	2610917203	Edge Guide
3	2610913432	Depth Marker	17	2610920879	Base plate Assy.
4	2610920044	Guide Plate Assy.	18	2610917207	Mounting Wrench
5	1603501018	Knurled Thumbscrew	19	2610917208	Guide Rod (2)
6	2603345015	Adjusting Nut (2)	20	2615294964	Square Nut (2)
7	2604511008	Compression Spring	21	2610915483	Nut (2)
8	2602305044	Detent Pin	22	2610914826	Circle Guide
9	2610918203	Hand Grip	23	2610914825	Clamp Screw #6-32 (4)
10	2610918204	Handle Cap	24	2615294965	Nail
11	2610918206	Handle Cap	25	2610920984	Bushing Plug
12	2916011884	Plain Washer (2)	26	2610920985	Guide Bushing 15/16"
13	2910011191	Cheese Head Screws (2)	27	2610920986	Guide Bushing 5/8"
14	2610358149	Nut (2)			

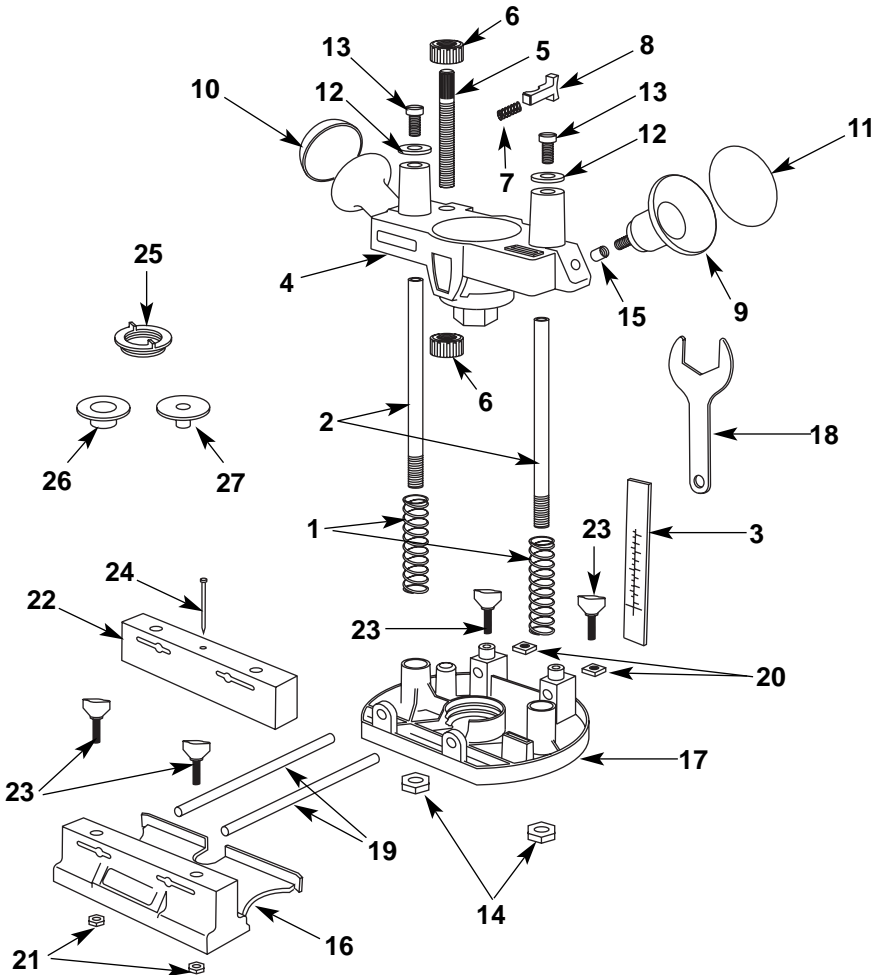

Dremel Limited Warranty

Your Dremel product is warranted against defective material or workmanship for a period of one year from date of purchase. In the event of a failure of a product to conform to this written warranty, please take the following action:

1. DO NOT return your product to the place of purchase.
2. Carefully package the product by itself, with no other items, and return it, freight prepaid, along with:
 - A. A copy of your dated proof of purchase (please keep a copy for yourself).
 - B. A written statement about the nature of the problem.
 - C. Your name, address and phone number to:

UNITED STATES

**Dremel Service Center
4915 Twenty-First Street
Racine, Wisconsin 53406**

Dremel Service Center
4631 E. Sunny Dunes
Palm Springs, CA 92264

OUTSIDE CONTINENTAL UNITED STATES

See your local distributor or write
to Dremel, 4915 Twenty-First
Street, Racine, Wisconsin 53406

CANADA

Clinique d' Outillage M.P.
3075 Boul, Hamel, Suite 107
Quebec City, Quebec G1P 4C6

Giles Tool Agencies
6520 Lawrence Avenue, East
Scarborough, Ontario M1C4A7

Service d'Outlis ACM
2071 Victoria Street
St. Lambert, Quebec J4S 1H1

Westcoast Tool
Unit 2-285 East First Avenue
Vancouver, B.C. V5T 1A8

We recommend that the package be insured against loss or in transit damage for which we cannot be responsible.

This warranty applies only to the original registered purchaser. **DAMAGE TO THE PRODUCT RESULTING FROM TAMPERING, ACCIDENT, ABUSE, NEGLIGENCE, UNAUTHORIZED REPAIRS OR ALTERATIONS, UNAPPROVED ATTACHMENTS OR OTHER CAUSES UNRELATED TO PROBLEMS WITH MATERIAL OR WORKMANSHIP ARE NOT COVERED BY THIS WARRANTY.**

No employee, agent, dealer or other person is authorized to give any warranties on behalf of Dremel. If Dremel inspection shows that the problem was caused by problems with material or workmanship within the limitations of the warranty, Dremel will repair or replace the product free of charge and return product prepaid. Repairs made necessary by normal wear or abuse, or repair for product outside the warranty period, if they can be made, will be charged at regular factory prices.

DREMEL MAKES NO OTHER WARRANTY OF ANY KIND WHATEVER, EXPRESSED OR IMPLIED, AND ALL IMPLIED WARRANTIES OF MERCHANTABILITY AND FITNESS FOR A PARTICULAR PURPOSE WHICH EXCEED THE ABOVE MENTIONED OBLIGATION ARE HEREBY DISCLAIMED BY DREMEL AND EXCLUDED FROM THIS LIMITED WARRANTY.

This warranty gives you specific legal rights and you may also have other rights which vary from state to state. The obligation of the warrantor is solely to repair or replace the product. The warrantor is not liable for any incidental or consequential damages due to any such alleged defect. Some states do not allow the exclusion or limitation of incidental or consequential damages, so the above limitations or exclusion may not apply to you.

For prices and warranty fulfillment in the continental United States, contact your local Dremel distributor.

Exportado por: Robert Bosch Tool Corporation Mt. Prospect, IL 60056 -2230, E.U.A.

Importado en México por: Robert Bosch, S.A. de C.V., Calle Robert Bosch No. 405,
Zona Industrial, Toluca, Edo. de México, C.P. 50070, Tel. (722) 2792300