

General Description

The XR31233, XR31234 and XR31235 are controller area network (CAN) transceivers that conform to the ISO 11898 standard. Each provides transmit and receive signaling rates up to 1Mbps between a differential CAN bus and a CAN controller.

These devices are designed with cross-wire protection, overvoltage protection up to ±36V, loss of ground protection, thermal shutdown protection and common-mode transient protection of ±100V making them ideal for harsh environments used in industrial, automotive, transportation and building automation applications.

The low power consumption of the 3.3V supply makes these CAN transceivers desirable and are fully interoperable with 5V supplied transceivers on the same bus. They also offer high speed, slope control and low-power standby modes of operation.

FEATURES

- Single 3.3V operation
- ±36V fault tolerance on analog bus pins
- Extended -25V to +25V common mode operation
- Robust ESD protection:
 - ±16kV HBM (bus pins)
 - ±8kV contact discharge (bus pins)
 - ±3kV HBM (non-bus pins)
- Up to 1Mbps data rates
- 11898-2 ISO compatible
- GIFT/ICT compliant
- 5V tolerant LVTTTL I/O's
- 200µA low current standby mode
- XR31233: Loopback mode
- XR31234: Ultra low current sleep mode
 - 50nA typical
- XR31235: Autobaud loopback mode

APPLICATIONS

- Industrial control systems
- Motor and robotic control
- Building and climate control (HVAC)
- Automotive and transportation

Typical Application

Ordering Information - [Back Page](#)

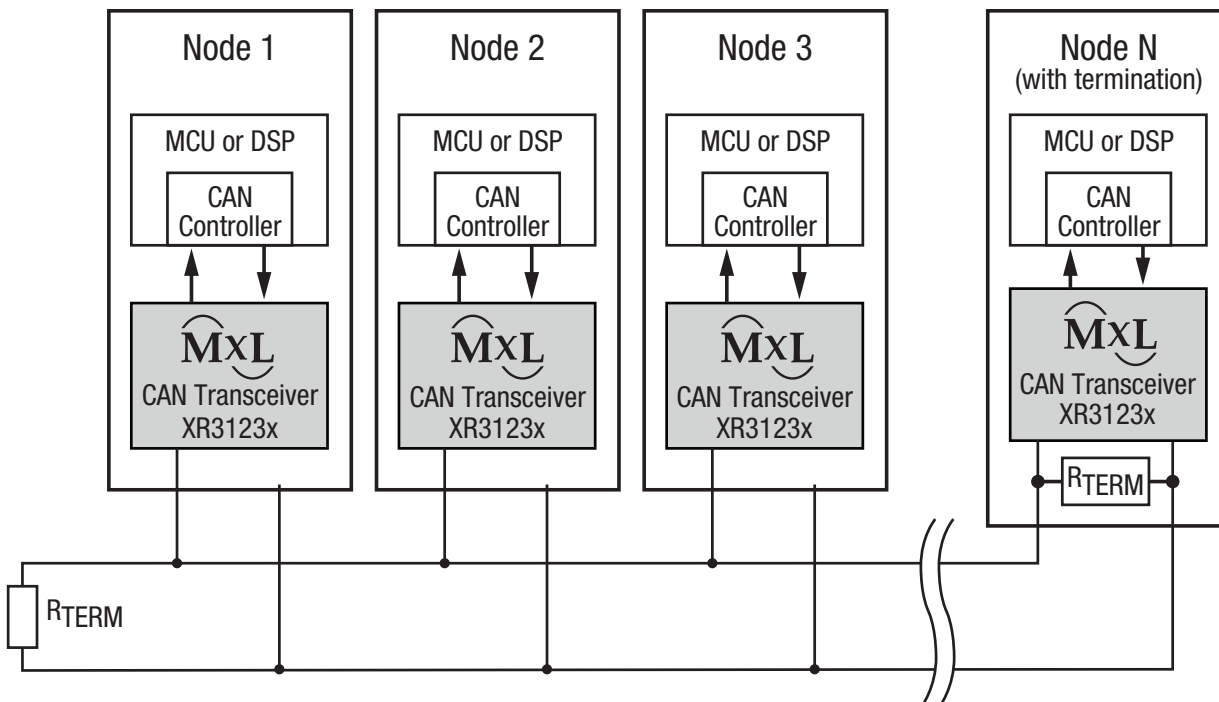

Figure 1: Typical CAN Bus

Absolute Maximum Ratings

Stresses beyond the limits listed below may cause permanent damage to the device. Exposure to any Absolute Maximum Rating condition may affect device reliability and lifetime.

V _{CC}	-0.3V to 7V
Voltage at any bus terminal (CANH or CANL)..	-36V to 36V
Voltage input, transient pulse, CANH and CANL, through 100Ω (Figure 9)	-100V to 100V
Input voltage (D, RS, EN, LBK, AB)	-0.5V to 7V
Output voltage	-0.5V to 7V
Receiver output current	-10mA to 10mA
Continuous total power dissipation.....	540mW
Operating junction temperature	150°C
Storage temperature.....	-65°C to 150°C
Lead temperature (soldering 10 seconds).....	300°C

Operating Conditions

V _{CC} supply range	3.0V to 3.6V
Operating temperature range	-40°C to 125°C
Package power dissipation, 8-pin NSOIC Θ_{JA}	128.4°C/W

ESD Ratings

Human Body Model (HBM), bus pins	±16kV
Human Body Model (HBM), non-bus pins	±3kV
IEC61000-4-2 (Contact Discharge), bus pins.....	±8kV

Electrical Characteristics

Unless otherwise noted: $V_{CC} = 3.0V$ to $3.6V$, $T_A = T_{MIN}$ to T_{MAX} . Typical values are at $V_{CC} = 3.3V$, $T_A = 25^\circ C$

Symbol	Parameter	Conditions	Min	Typ	Max	Units	
Driver DC Characteristics							
$V_{O(D)}$	Bus output voltage (Dominant)	CANH	D at 0V, RS at 0V, see Figure 3 and Figure 4	2.3		V_{CC}	V
		CANL		0.5		1.25	
V_O	Bus output voltage (Recessive)	CANH	D at 3V, RS at 0V, see Figure 3 and Figure 4		2.3		V
		CANL			2.3		
$V_{OD(D)}$	Differential output voltage (Dominant)		D at 0V, RS at 0V, see Figure 3 and Figure 4	1.5	2	3	V
			D at 0V, RS at 0V, see Figure 4 and Figure 5	1.2	2	3	
V_{OD}	Differential output voltage (Recessive)		D at 3V, RS at 0V, see Figure 3 and Figure 4	-120		12	mV
			D at 3V, RS at 0V, No Load	-0.5		0.05	V
$V_{OC(PP)}$	Peak-to-peak common-mode output voltage		See Figure 12		1		V
I_{IH}	High-level input current	D, EN, LBK, AB	D = 2V or EN = 2V or LBK = 2V or AB = 2V	-30		30	μA
I_{IL}	Low-level input current	D, EN, LBK, AB	D = 0.8V or EN = 0.8V or LBK = 0.8V or AB = 0.8V	-30		30	μA
I_{OS}	Short-circuit output current		VCANH = -25V, CANL Open, see Figure 17	-250			mA
			VCANH = 25V, CANL Open, see Figure 17			3	
			VCANH = -25V, CANH Open, see Figure 17	-3			
			VCANH = 25V, CANH Open, see Figure 17			250	
C_O	Output capacitance		See receiver input capacitance				
$I_{RS(S)}$	RS input current for standby		RS at 0.75 Vcc	-10			μA
I_{CC}	Supply current	Sleep	EN at 0V, D at V_{CC} , RS at 0V or VCC		0.05	2	μA
		Standby	RS at V_{CC} , D at V_{CC} , AB at 0V, LBK at 0V, EN at V_{CC}		200	600	
		Dominant	D at 0V, No Load, AB at 0V, LBK at 0V			6	mA
		Recessive	D at V_{CC} , No Load, AB at 0V, LBK at 0V, RS at 0V, EN at V_{CC}			6	

Electrical Characteristics, (Continued)

Unless otherwise noted: $V_{CC} = 3.0V$ to $3.6V$, $T_A = T_{MIN}$ to T_{MAX} . Typical values are at $V_{CC} = 3.3V$, $T_A = 25^{\circ}C$.

Symbol	Parameter	Conditions	Min	Typ	Max	Units	
Receiver DC Characteristics							
V_{IT+}	Positive-going input threshold voltage	AB at 0V, LBK at 0V, EN at V_{CC} , see Table 1		750	900	mV	
V_{IT-}	Negative-going input threshold voltage		500	650			
V_{HYS}	Hysteresis voltage (V_{IT+} to V_{IT-})			100			
V_{OH}	High-level output voltage	$V_{CC} < 3.3V$, $I_O = -4mA$, see Figure 8	2.0			V	
		$V_{CC} \geq 3.0V$, $I_O = -4mA$, see Figure 8	2.4				
V_{OL}	Low-level output voltage	$I_O = 4mA$, see Figure 8			0.4		
I_I	Bus input current	CANH or CANL at 25V	Other bus pin at 0V, D at 3V, AB at 0V, LBK at 0V, RS at 0V, EN at V_{CC}	400		1250	μA
		CANH or CANL at -25V		-1400		-500	
C_I	Input capacitance (CANH or CANL)	Pin-to-ground, $V_I = 0.4 \sin(4E6\pi t) + 0.5V$, D at 3V, AB at 0V, LBK at 0V, EN at V_{CC}		40		pF	
C_{ID}	Differential input capacitance	Pin-to-pin, $V_I = 0.4 \sin(4E6\pi t) + 0.5V$, D at 3V, AB at 0V, LBK at 0V, EN at V_{CC}		20		pF	
R_{ID}	Differential input resistance	D at 3V, AB at 0V, LBK at 0V, EN at V_{CC}	40		100	k Ω	
R_{IN}	Input resistance (CANH or CANL) to ground		20		50	k Ω	

Electrical Characteristics (Continued)

Unless otherwise noted: $V_{CC} = 3.0V$ to $3.6V$, $T_A = T_{MIN}$ to T_{MAX} . Typical values are at $V_{CC} = 3.3V$, $T_A = 25^{\circ}C$.

Symbol	Parameter	Conditions	Min	Typ	Max	Units
Driver AC Characteristics						
t_{PLH}	Propagation delay time, low-to-high-level output	RS at 0V, see Figure 6		35	85	ns
		RS with 10k Ω to ground, see Figure 6		70	125	
		RS with 100k Ω to ground, see Figure 6		500	870	
t_{PHL}	Propagation delay time, high-to-low-level output	RS at 0V, see Figure 6		70	120	ns
		RS with 10k Ω to ground, see Figure 6		130	180	
		RS with 100k Ω to ground, see Figure 6		870	1200	
$t_{sk(p)}$	Pulse skew ($ t_{PHL} - t_{PLH} $)	RS at 0V, see Figure 6		35		ns
		RS with 10k Ω to ground, see Figure 6		60		
		RS with 100k Ω to ground, see Figure 6		370		
t_r	Differential output signal rise time	RS at 0V, see Figure 6	5		70	ns
t_f	Differential output signal fall time		5		70	ns
t_r	Differential output signal rise time	RS with 10k Ω to ground, see Figure 6	30		135	ns
t_f	Differential output signal fall time		30		135	ns
t_r	Differential output signal rise time	RS with 100k Ω to ground, see Figure 6	350		1400	ns
t_f	Differential output signal fall time		350		1400	ns
$t_{en(s)}$	Enable time from standby to dominant	See Figure 10		0.6	1.5	μs
$t_{en(z)}$	Enable time from sleep to dominant	XR31234 See Figure 11		1	5	μs
Receiver AC Characteristics						
t_{PLH}	Propagation delay time, low-to-high-level output	See Figure 8		35	60	ns
t_{PHL}	Propagation delay time, high-to-low-level output			35	60	ns
$t_{sk(p)}$	Pulse skew ($ t_{PHL} - t_{PLH} $)			7		ns
t_r	Output signal rise time ⁽¹⁾				5	ns
t_f	Output signal fall time ⁽¹⁾				5	ns

NOTE:

1. This spec is guaranteed by design and bench characterization.

Electrical Characteristics, (Continued)

Unless otherwise noted: $V_{CC} = 3.0V$ to $3.6V$, $T_A = T_{MIN}$ to T_{MAX} . Typical values are at $V_{CC} = 3.3V$, $T_A = 25^{\circ}C$.

Symbol	Parameter	Conditions	Min	Typ	Max	Units
Device AC Characteristics						
$t_{(LBK)}$	Loopback delay, driver input to receiver output	XR31233	See Figure 14	7.5	12	ns
$t_{(AB1)}$	Loopback delay, driver input to receiver output	XR31235	See Figure 15	10	20	ns
$t_{(AB2)}$	Loopback delay, bus input to receiver output		See Figure 16	35	60	ns
$t_{(loop1)}$	Total loop delay, driver input to receiver output, recessive to dominant	RS at 0V, see Figure 13		70	135	ns
		RS with 10k Ω to ground, see Figure 13		105	190	
		RS with 100k Ω to ground, see Figure 13		535	1000	
$t_{(loop2)}$	Total loop delay, driver input to receiver output, dominant to recessive	RS at 0V, See Figure 13		70	135	ns
		RS with 10k Ω to ground, see Figure 13		105	190	
		RS with 100k Ω to ground, see Figure 13		535	1000	

Pin Configuration

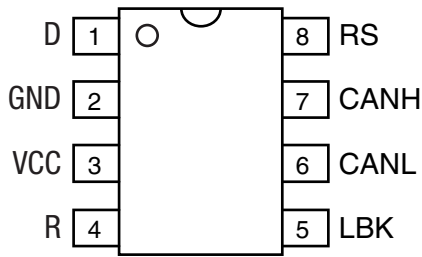

Top View, XR31233

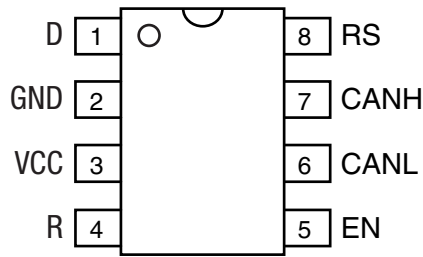

Top View, XR31234

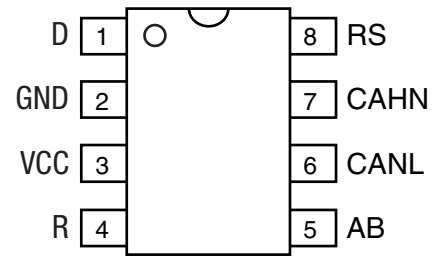

Top View, XR31235

Pin Functions

Pin Number	Pin Name	Type	Description			
1	D	Input	CAN transmit data input (LOW for dominant and HIGH for recessive bus states), also called TXD, driver input.			
2	GND	Power	Ground.			
3	VCC	Power	3.3V power supply input, bypass to ground with 0.1μF capacitor.			
4	R	Output	CAN receive data output (LOW for dominant and HIGH for recessive bus states), also called RXD, receiver output.			
5	LBK	Input	XR31233	Loopback mode input.	LBK = 1	Loopback mode. D input loops back to R output. D input does not drive or affect the activity of the CAN bus. Useful for checking connectivity and running diagnostics without disturbing the CAN bus.
					LBK = 0	Normal mode. D input drives CAN bus. If D = 0, the CAN bus is dominant. If D = 1 the CAN bus is recessive. See Figure 4.
	EN	Input	XR31234	Enable input.	EN = 1	Normal mode. D input drives CAN bus. If D = 0, the CAN bus is dominant. If D = 1 the CAN bus is recessive. See Figure 4.
					EN = 0	Sleep mode, low power.
	AB	Input	XR31235	Autobaud loopback mode input.	AB = 1	Autobaud loopback mode. Similar to loopback mode as the D input loops back to R output, except that the R output is a NOR function of the D input and the CAN bus activity. Useful for checking connectivity, running diagnostics and monitoring CAN bus activity, which allows local mode to detect and sync the baud rate up on the CAN bus.
					AB = 0	Normal mode. D input drives CAN bus. If D = 0, the CAN bus is dominant. If D = 1 the CAN bus is recessive. See Figure 4
6	CANL	I/O	Low level CAN bus line.			
7	CANH	I/O	High level CAN bus line.			
8	RS	Input	Mode select pin: strong pulldown to GND = high speed mode, strong pullup to VCC = low power mode, 10kΩ to 100kΩ pulldown to GND = slope control mode.			

Device Functional Modes

Driver (XR31233 or XR31235)

Inputs			Outputs		
D	LBK/AB	RS	CANH	CANL	Bus State
X	X	$> 0.75 V_{CC}$	Z	Z	Recessive
L	L or open	$\leq 0.33 V_{CC}$	H	L	Dominant
H or open	X		Z	Z	Recessive
X	H	$\leq 0.33 V_{CC}$	Z	Z	Recessive

Receiver (XR31233)

Inputs				Output
Bus State	$V_{ID} = V_{CANH} - V_{CANL}$	LBK	D	R
Dominant	$V_{ID} \geq 0.9V$	L or open	X	L
Recessive	$V_{ID} \leq 0.5V$ or open	L or open	H or open	H
?	$0.5V < V_{ID} < 0.9V$	L or open	H or open	?
X	X	H	L	L
X	X		H	H

Receiver (XR31235)

Inputs				Output
Bus State	$V_{ID} = V_{CANH} - V_{CANL}$	AB	D	R
Dominant	$V_{ID} \geq 0.9V$	L or open	X	L
Recessive	$V_{ID} \leq 0.5V$ or open	L or open	H or open	H
?	$0.5V < V_{ID} < 0.9V$	L or open	H or open	?
Dominant	$V_{ID} \geq 0.9V$	H	X	L
Recessive	$V_{ID} \leq 0.5V$ or open	H	H	H
Recessive	$V_{ID} \leq 0.5V$ or open	H	L	L
?	$0.5V < V_{ID} < 0.9V$	H	L	L

Driver (XR31234)

Inputs			Outputs		
D	EN	RS	CANH	CANL	Bus State
L	H	$\leq 0.33 V_{CC}$	H	L	Dominant
H	X	$\leq 0.33 V_{CC}$	Z	Z	Recessive
Open	X	X	Z	Z	Recessive
X	X	$> 0.75 V_{CC}$	Z	Z	Recessive
X	L or open	X	Z	Z	Recessive

Device Functional Modes (Continued)

Receiver (XR31234)

Inputs			Output
Bus State	$V_{ID} = V_{CANH} - V_{CANL}$	EN	R
Dominant	$V_{ID} \geq 0.9V$	H	L
Recessive	$V_{ID} \leq 0.5V$ or open	H	H
?	$0.5V < V_{ID} < 0.9V$	H	?
X	X	L or open	H

H = high level; L = low level; Z = high impedance; X = irrelevant; ? = indeterminate

Applications Information

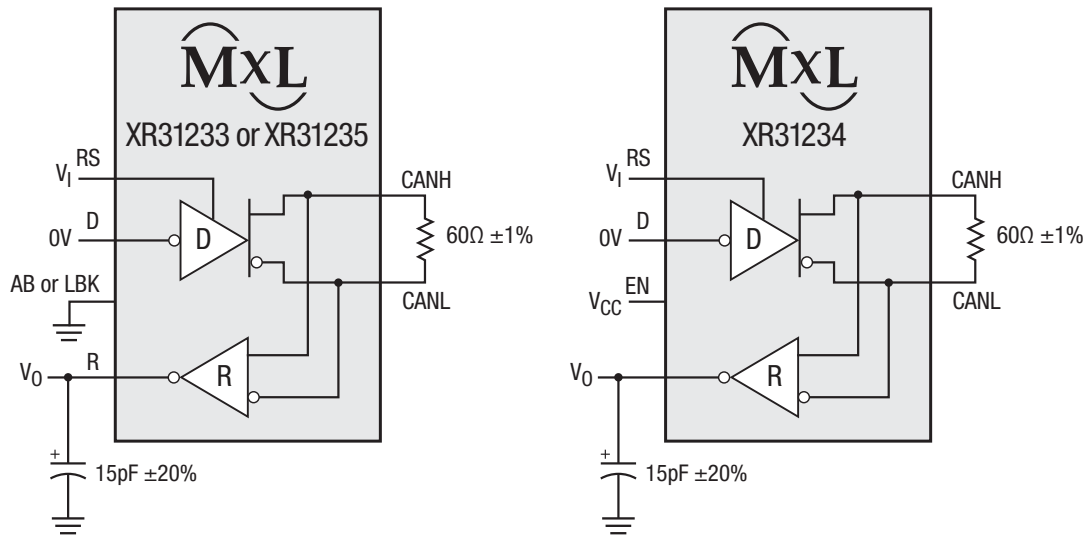

Figure 2: Functional Diagram

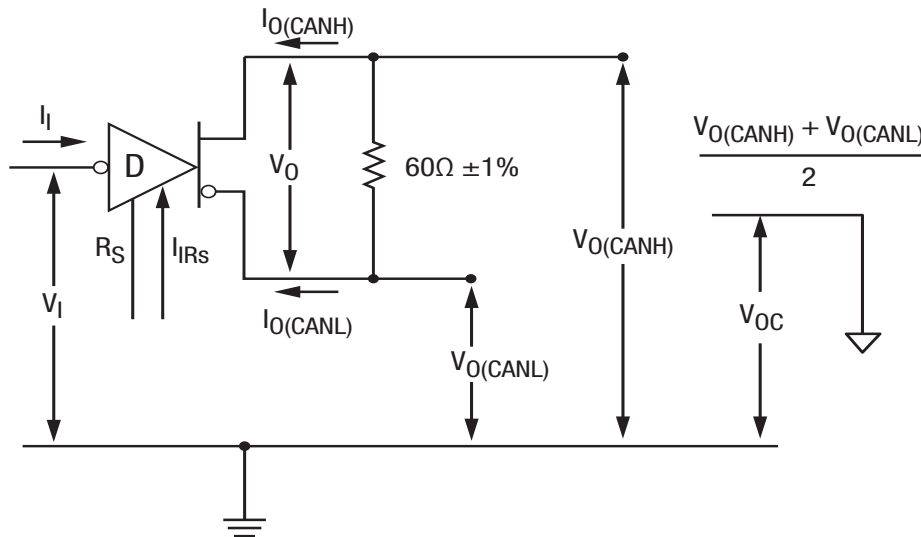

Figure 3: Driver Voltage, Current and Test Definition

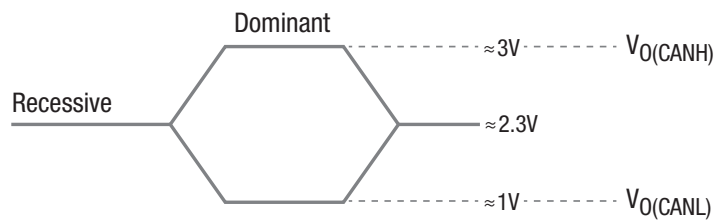

Figure 4: Bus Logic State Voltage Definitions

Applications Information (Continued)

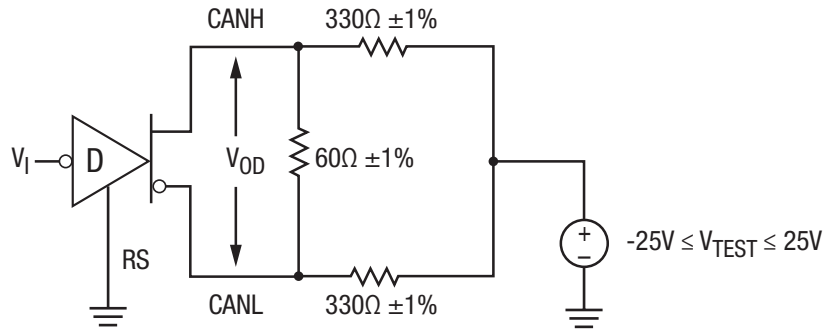
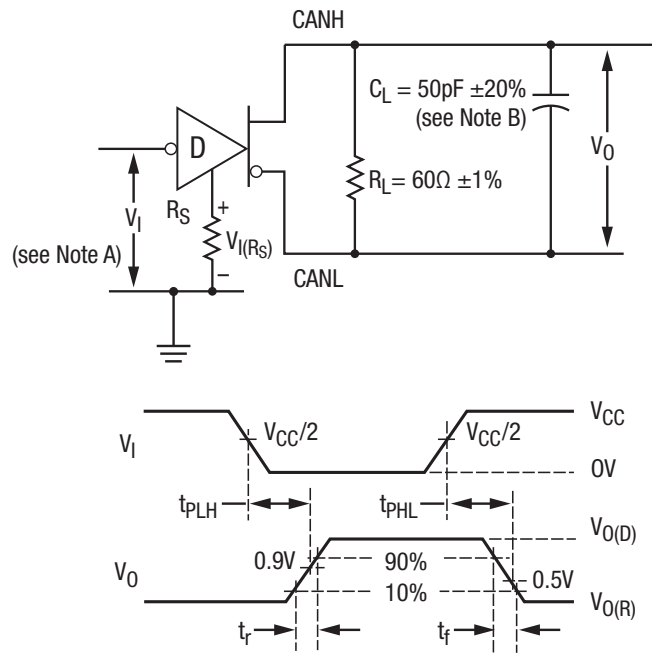

Figure 5: Driver V_{OD}



NOTES:

- A. Pulse input: $\leq 125\text{kHz}$, 50% duty cycle, $t_r \leq 6\text{ns}$, $t_f \leq 6\text{ns}$, $Z_0 = 50\Omega$
- B. C_L includes fixture and instrumentation capacitance

Figure 6: Driver Test Circuit and Voltage Waveforms

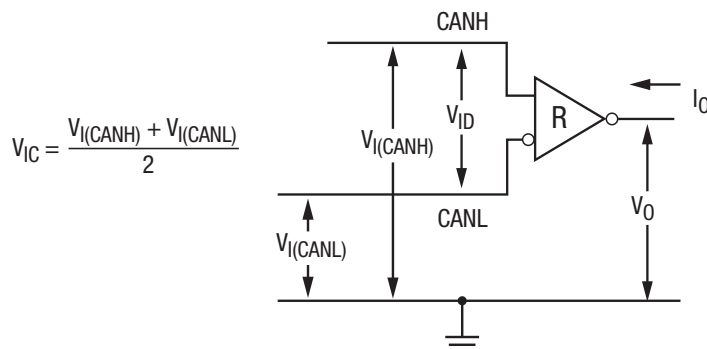
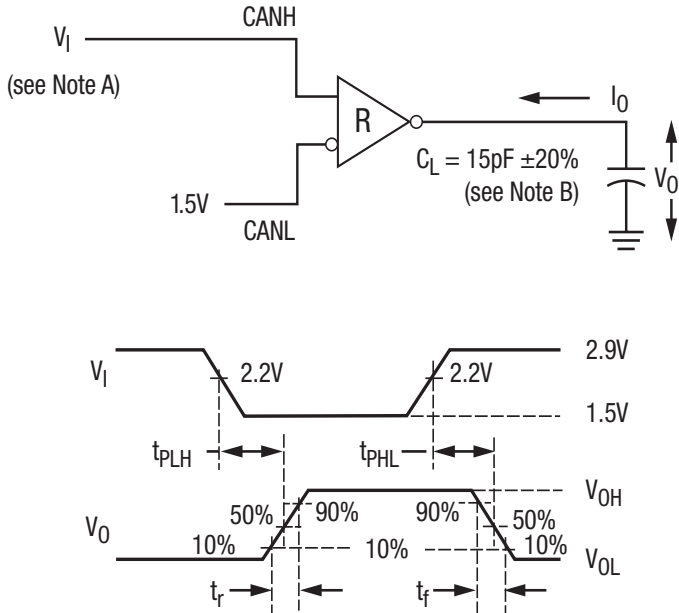

Figure 7: Receiver Voltage and Current Definitions

Applications Information (Continued)



NOTES:

- A. Pulse input: $\leq 125\text{kHz}$, 50% duty cycle, $t_r \leq 6\text{ns}$, $t_f \leq 6\text{ns}$, $Z_O = 50\Omega$
- B. C_L includes fixture and instrumentation capacitance

Figure 8: Receiver Test Circuit and Voltage Waveforms

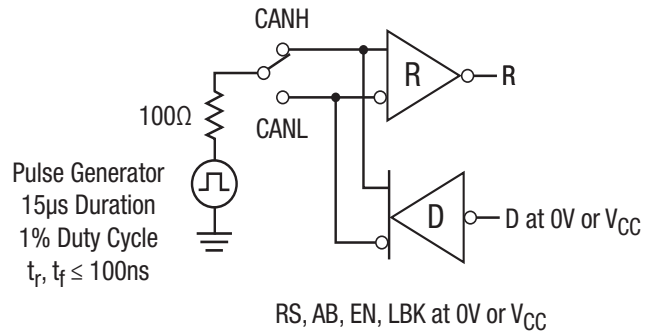

NOTE:

This test is conducted to test survivability only. Data stability at the R output is not specified.

Figure 9: Test Circuit, Transient Overvoltage Test

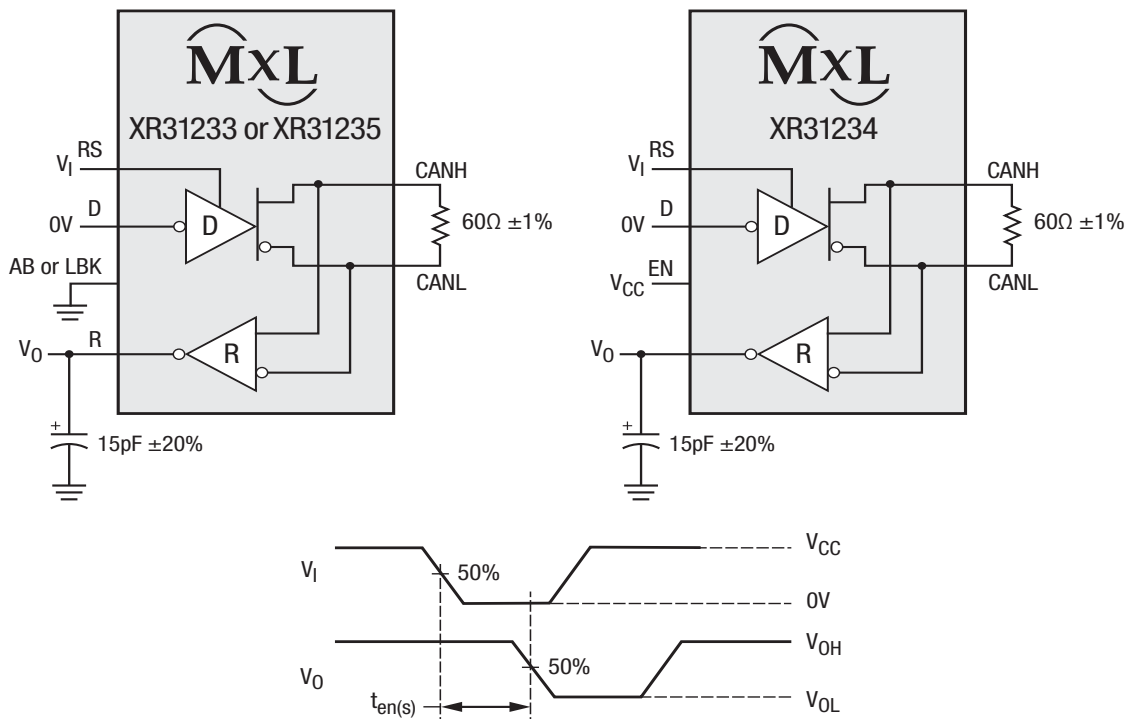

NOTES:

- V_I Pulse input: $\leq 125\text{kHz}$, 50% duty cycle, $t_r \leq 6\text{ns}$, $t_f \leq 6\text{ns}$, $Z_O = 50\Omega$

Figure 10: Ten(s) Test Circuit and Voltage Waveforms

Applications Information (Continued)

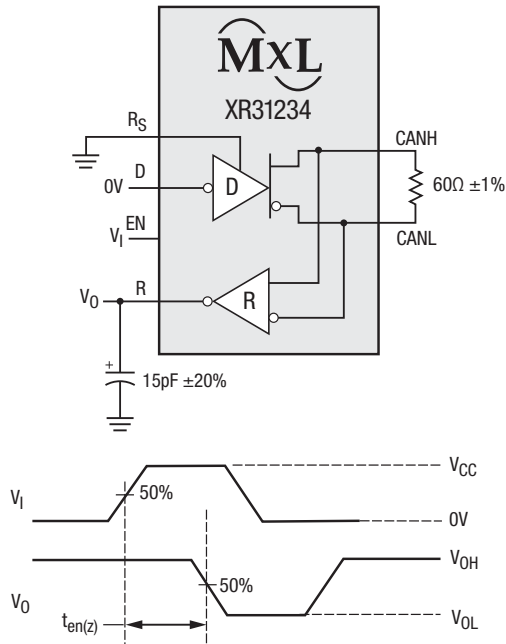

NOTES:
 V₁ Pulse input: ≤125kHz, 50% duty cycle, t_r ≤ 6ns, t_f ≤ 6ns, Z_O = 50Ω
 Figure 11: T_{en(z)} Test Circuit and Voltage Waveforms

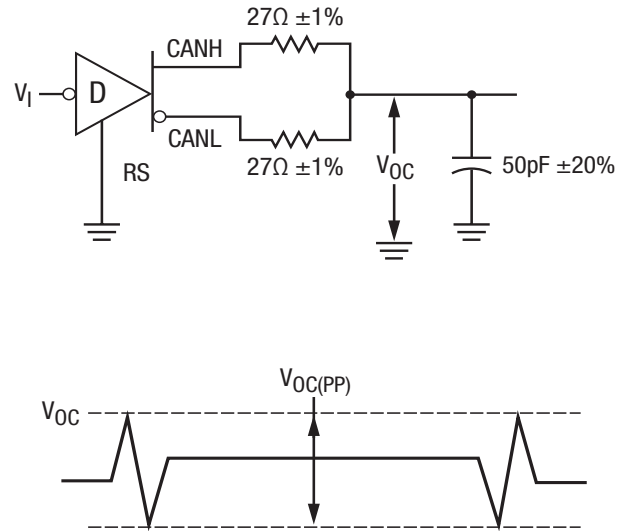

NOTES:
 V₁ Pulse input: ≤125kHz, 50% duty cycle, t_r ≤ 6ns, t_f ≤ 6ns, Z_O = 50Ω
 Figure 12: V_{OC(pp)} Test Circuit and Voltage Waveforms

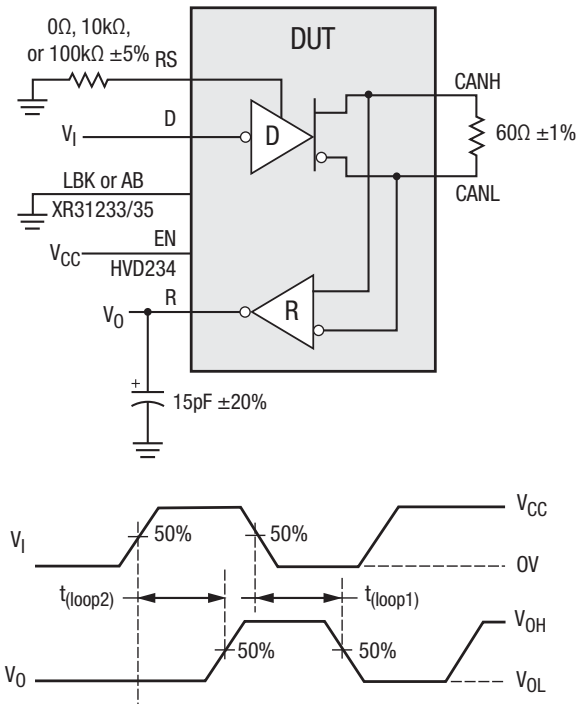

NOTES:
 V₁ Pulse input: ≤125kHz, 50% duty cycle, t_r ≤ 6ns, t_f ≤ 6ns, Z_O = 50Ω
 Figure 13: T_(loop) Test Circuit and Voltage Waveforms

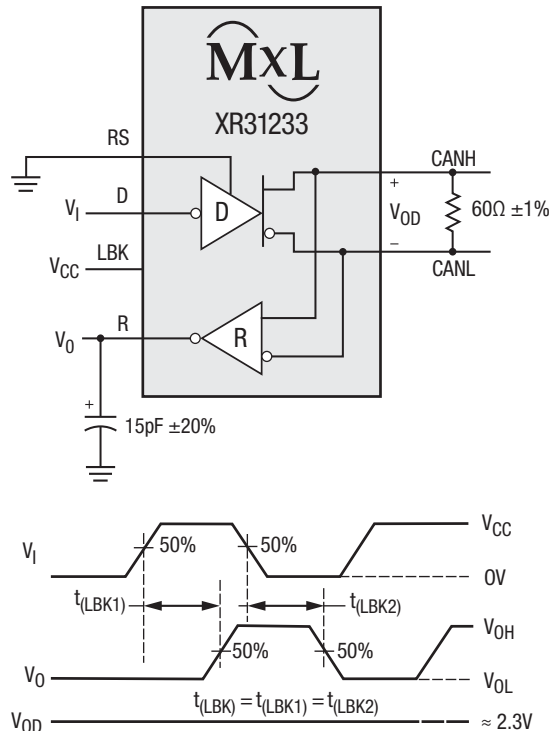

NOTES:
 V₁ Pulse input: ≤125kHz, 50% duty cycle, t_r ≤ 6ns, t_f ≤ 6ns, Z_O = 50Ω
 Figure 14: T_(LBK) Test Circuit and Voltage Waveforms

Applications Information (Continued)

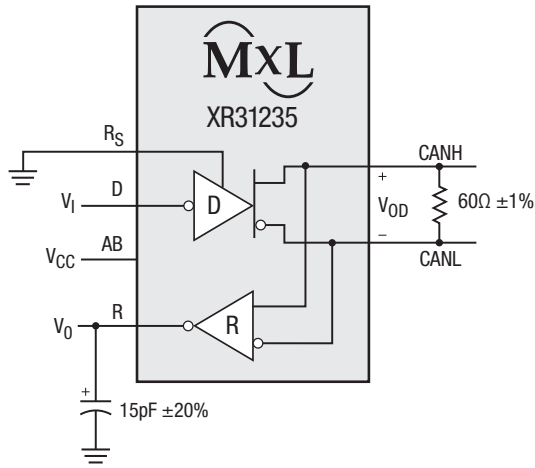

NOTES:
 V_I Pulse input: ≤125kHz, 50% duty cycle, t_r ≤ 6ns, t_f ≤ 6ns, Z_O = 50Ω

Figure 15: T_(AB1) Test Circuit and Voltage Waveforms

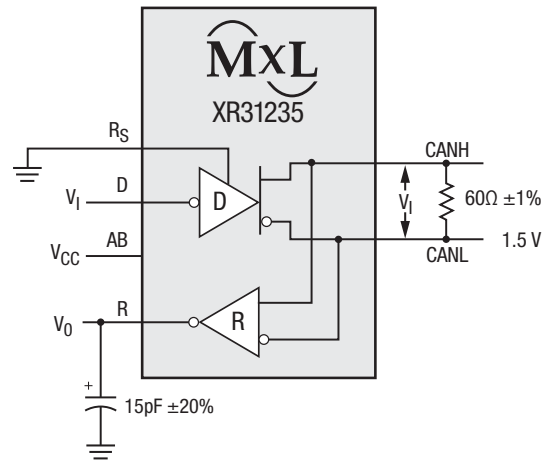

NOTES:
 V_I Pulse input: ≤125kHz, 50% duty cycle, t_r ≤ 6ns, t_f ≤ 6ns, Z_O = 50Ω

Figure 16: T_(AB2) Test Circuit and Voltage Waveforms

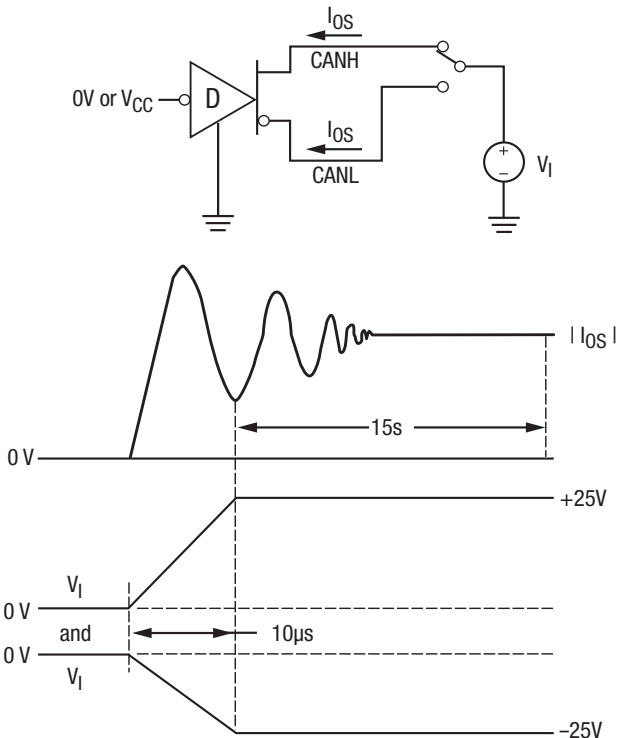
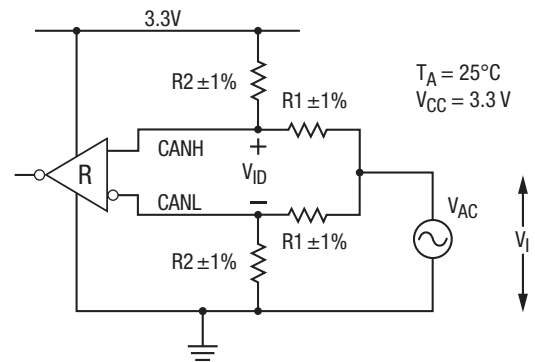

Figure 17: I_{OS} Test Circuit and Waveforms



The R output state does not change during application of the input waveform

V _{ID}	R1	R2
500mV	50Ω	280Ω
900mV	50Ω	130Ω

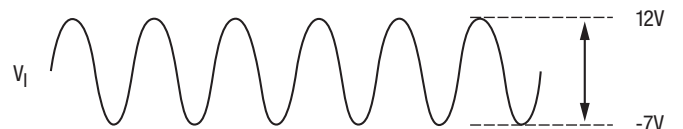
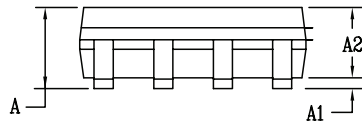
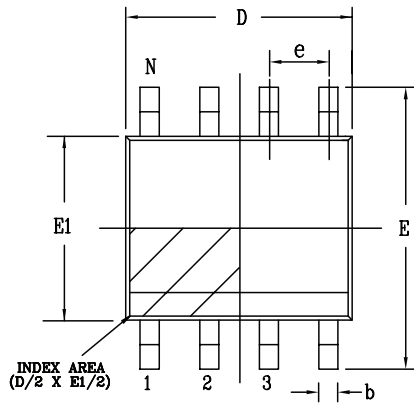

Figure 18: Common-Mode Voltage Rejection

Mechanical Dimensions

NSOIC-8

Top View



Side View

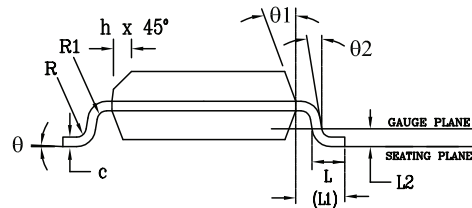

Front View

PACKAGE OUTLINE NSOIC .150" BODY JEDEC MS-012 VARIATION AA						
SYMBOLS	COMMON DIMENSIONS IN MM (Control Unit)			COMMON DIMENSIONS IN INCH (Reference Unit)		
	MIN	NOM	MAX	MIN	NOM	MAX
A	1.35	—	1.75	0.053	—	0.069
A1	0.10	—	0.25	0.004	—	0.010
A2	1.25	—	1.65	0.049	—	0.065
b	0.31	—	0.51	0.012	—	0.020
c	0.17	—	0.25	0.007	—	0.010
E	6.00 BSC			0.236 BSC		
E1	3.90 BSC			0.154 BSC		
e	1.27 BSC			0.050 BSC		
h	0.25	—	0.50	0.010	—	0.020
L	0.40	—	1.27	0.016	—	0.050
L1	1.04 REF			0.041 REF		
L2	0.25 BSC			0.010 BSC		
R	0.07	—	—	0.003	—	—
R1	0.07	—	—	0.003	—	—
q	0°	—	8°	0°	—	8°
q1	5°	—	15°	5°	—	15°
q2	0°	—	—	0°	—	—
D	4.90 BSC			0.193 BSC		
N	8					

Drawing No: POD-0000108

Revision: A

Ordering Information⁽¹⁾

Part Number	Operating Temperature Range	Lead-Free	Package	Packaging Method	Feature ⁽³⁾
XR31233ED	-40°C to +125°C	Yes ⁽²⁾	NSOIC-8	Tube	Loopback mode
XR31233EDTR				Tape and Reel	
XR31234ED				Tube	Sleep mode
XR31234EDTR				Tape and Reel	
XR31235ED				Tube	Autobaud loopback mode
XR31235EDTR				Tape and Reel	
XR31233EDEVB	XR31233 Evaluation Board				
XR31234EDEVB	XR31234 Evaluation Board				
XR31235EDEVB	XR31235 Evaluation Board				

NOTE:

1. Refer to www.exar.com/XR31233, www.exar.com/XR31234, www.exar.com/XR31235 for most up-to-date Ordering Information.
2. Visit www.exar.com for additional information on Environmental Rating.
3. See [pin 5 function](#) for selection between XR31233, XR31234 and XR31235.

Revision History

Revision	Date	Description
1A	August 2017	Initial Release



Corporate Headquarters:
 5966 La Place Court
 Suite 100
 Carlsbad, CA 92008
 Tel.: +1 (760) 692-0711
 Fax: +1 (760) 444-8598
www.maxlinear.com

High Performance Analog:
 48760 Kato Road
 Fremont, CA 94538
 Tel.: +1 (510) 668-7000
 Fax: +1 (510) 668-7001
 Email: Serialtechsupport@exar.com
www.exar.com

The content of this document is furnished for informational use only, is subject to change without notice, and should not be construed as a commitment by MaxLinear, Inc.. MaxLinear, Inc. assumes no responsibility or liability for any errors or inaccuracies that may appear in the informational content contained in this guide. Complying with all applicable copyright laws is the responsibility of the user. Without limiting the rights under copyright, no part of this document may be reproduced into, stored in, or introduced into a retrieval system, or transmitted in any form or by any means (electronic, mechanical, photocopying, recording, or otherwise), or for any purpose, without the express written permission of MaxLinear, Inc.

MaxLinear, Inc. does not recommend the use of any of its products in life support applications where the failure or malfunction of the product can reasonably be expected to cause failure of the life support system or to significantly affect its safety or effectiveness. Products are not authorized for use in such applications unless MaxLinear, Inc. receives, in writing, assurances to its satisfaction that: (a) the risk of injury or damage has been minimized; (b) the user assumes all such risks; (c) potential liability of MaxLinear, Inc. is adequately protected under the circumstances.

MaxLinear, Inc. may have patents, patent applications, trademarks, copyrights, or other intellectual property rights covering subject matter in this document. Except as expressly provided in any written license agreement from MaxLinear, Inc., the furnishing of this document does not give you any license to these patents, trademarks, copyrights, or other intellectual property.

Company and product names may be registered trademarks or trademarks of the respective owners with which they are associated.

Mouser Electronics

Authorized Distributor

Click to View Pricing, Inventory, Delivery & Lifecycle Information:

[MaxLinear:](#)

[XR31234EDTR](#) [XR31233EDTR](#) [XR31235EDTR](#) [XR31235ED](#) [XR31234ED](#) [XR31233ED](#)