

THIS DOCUMENT IS THE PROPERTY OF KEYSTONE ELECTRONICS CORP. AND SHALL NOT BE REPRODUCED, DISTRIBUTED OR USED AS A BASIS FOR MANUFACTURE WITHOUT PRIOR WRITTEN PERMISSION FROM KEYSTONE ELECTRONICS CORP.

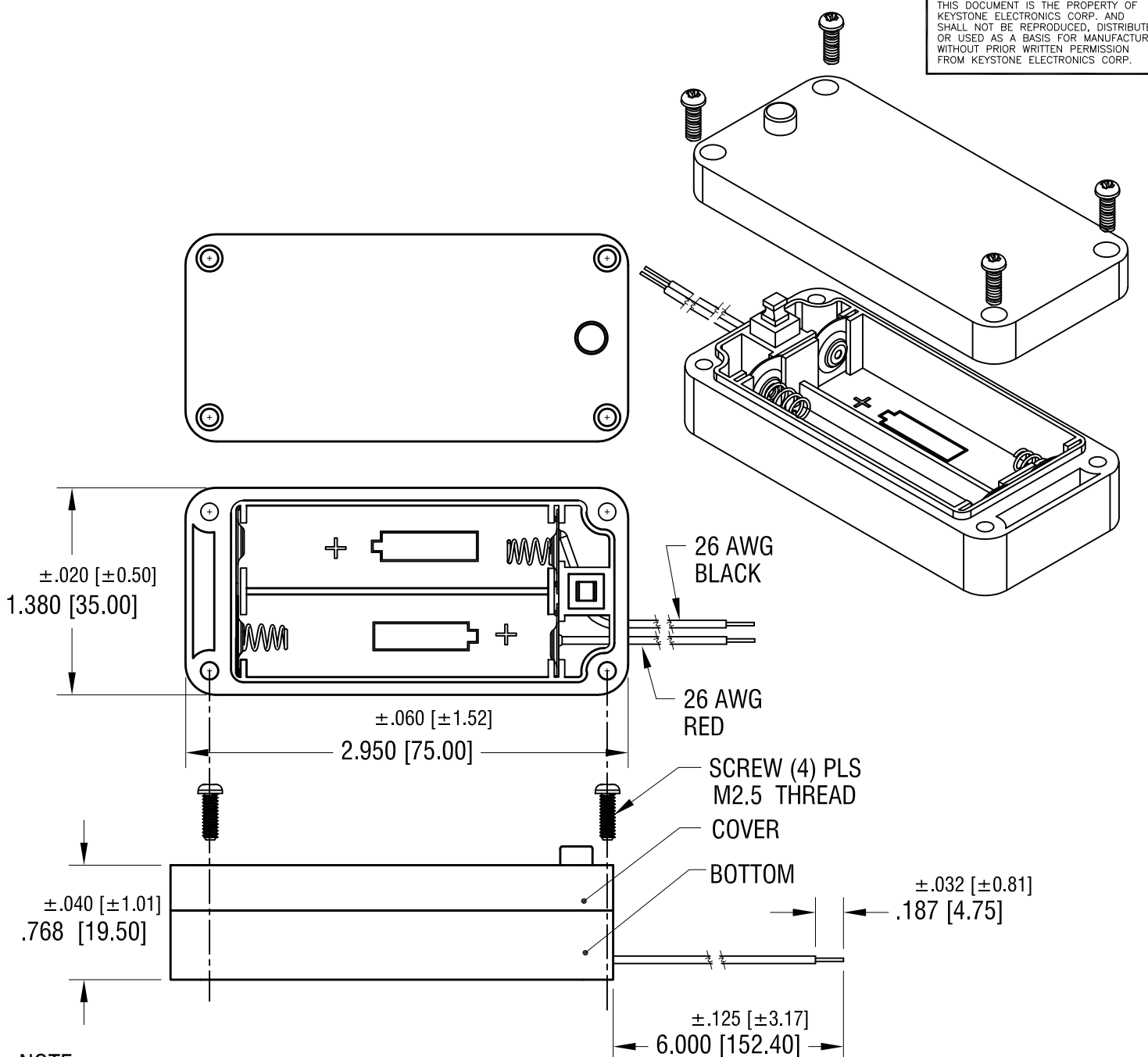

NOTE:

1. HOLDER: MAT'L: ABS
2. SPRING: MAT'L: MUSIC WIRE, .020 [0.50] DIA.
FINISH: NICKEL PLATE
3. SCREW: MAT'L- STEEL, ZINC PLATED
4. IP65 RATED FOR WATER, DUST AND HARSH ENVIRONMENTS

KEYSTONE ELECTRONICS CORP.			
www.keyelco.com • NEW HYDE PARK, NY 11040 • Tel (516) 328-7500			
PART NAME			
WATER RESISTANT BATTERY HOLDER (2) 'AA'			
MATERIAL			
AS NOTED			
FINISH		DRN BY	DATE
AS NOTED		NT	5.09.18
		APP'D	SCALE
		LN	1X
TOLERANCES	INCH	[MM]	CODE
DECIMAL	± .010	[± 0.25]	C
ANGULAR	± 1°		DWG NO.
UNLESS OTHERWISE SPECIFIED			2438

DATE	DESCRIPTION	REV.

Mouser Electronics

Authorized Distributor

Click to View Pricing, Inventory, Delivery & Lifecycle Information:

[Keystone Electronics:](#)

[2438](#)