

# 440H\*120

## REVISIONS

SYM.	DESCRIPTION	DATE	APPROVED
A	RELEASED	11/02/07	T. L.
B	REVISED PER DCN 29177	03/13/08	T. L.

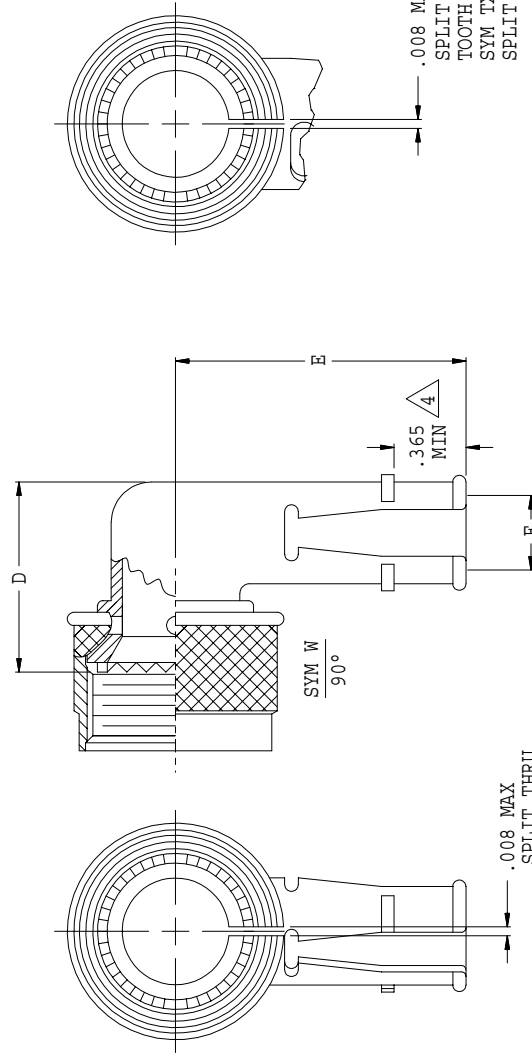
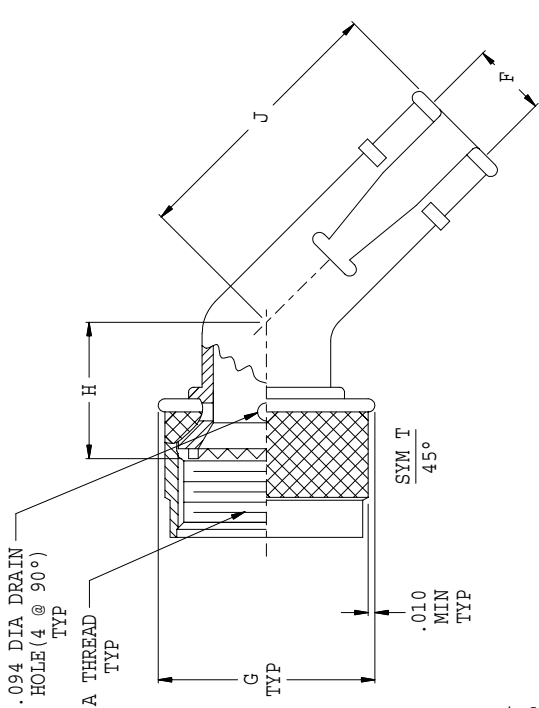
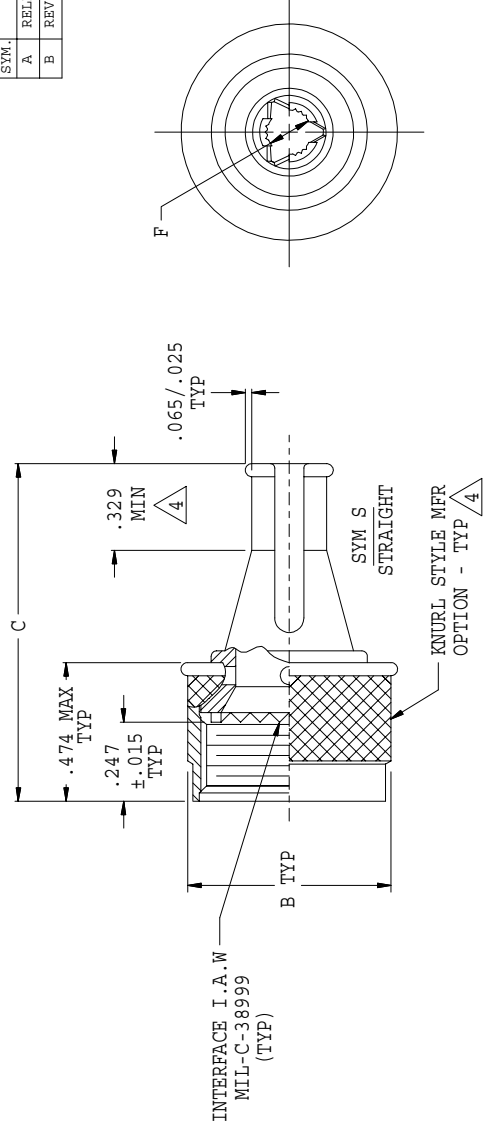

THIS COPYRIGHTED DOCUMENT IS THE PROPERTY OF GLENAIR, INC. AND IS FURNISHED ON THE CONDITION THAT IT IS NOT TO BE DISCLOSED, REPRODUCED IN WHOLE OR IN PART, OR USED TO SOLICIT QUOTATIONS FROM COMPETITIVE SOURCES, OR USED FOR MANUFACTURE BY ANYONE OTHER THAN GLENAIR, INC. WITHOUT WRITTEN PERMISSION FROM GLENAIR, INC. THE INFORMATION HEREIN HAS BEEN DEVELOPED AT GLENAIR'S EXPENSE AND MAY BE USED FOR ENGINEERING EVALUATION AND INCORPORATION INTO TECHNICAL SPECIFICATIONS AND OTHER DOCUMENTS WHICH SPECIFY PROCUREMENT OF PRODUCTS FROM GLENAIR, INC.

DRAWN	T. LE	04/21/03	CAD 2003
CHECK	R. PAINTER	04/21/03	
ENGR	T. YOUNG	04/21/03	
<b>GLENAIR, INC.</b>			
1211 AIR WAY - GLENDALE - CALIFORNIA 91201			
ADAPTER, BANDING, RFI/EMI, STRAIN RELIEF FOR MIL-DTL-38999 SERIES III & IV CONNECTORS			
DO NOT SCALE THIS DRAWING	RELEASE DATE	APPROVED	REV.
B/F 98-5746 P/C 44	11/02/07	<i>R. Parks</i>	C 440H*120 B
NON REPAIRABLE COMMERCIAL ITEM	SCALE N/A	WEIGHT N/A	SHEET 1 OF 2

BOEING ONLY  
5M2919, 5M2920, 5M2953

REVISIONS	
SYM.	DESCRIPTION
SEE SHEET 1	
	DATE
	APPROVED

SHELL SIZE	A THREAD ISO METRIC	B MAX	C MAX DIM	D +.03 -.06 DIM	E MAX DIM	F CABLE DIA		G MAX	H MAX	J MAX
						MAX	MIN			
09	M12 X 1.0 - 6H	.594	1.46	.66	1.02	.203	.094	.65	.470	1.02
11	M15 X 1.0 - 6H	.718	1.46	.69	1.07	.250	.141	.76	.482	1.07
13	M18 X 1.0 - 6H	.844	1.46	.75	1.13	.323	.172	.89	.494	1.13
15	M22 X 1.0 - 6H	1.000	1.46	.86	1.33	.422	.203	1.04	.530	1.33
17	M25 X 1.0 - 6H	1.188	1.46	.94	1.40	.500	.234	1.14	.557	1.40
19	M28 X 1.0 - 6H	1.218	1.46	1.00	1.46	.562	.265	1.28	.576	1.46
21	M31 X 1.0 - 6H	1.344	1.54	1.07	1.61	.625	.297	1.40	.600	1.61
23	M34 X 1.0 - 6H	1.469	1.54	1.15	1.66	.703	.328	1.51	.627	1.66
25	M37 X 1.0 - 6H	1.594	1.54	1.21	1.72	.765	.359	1.63	.653	1.72

TABLE I

PART NUMBER DEVELOPMENT

EXAMPLE: 440 H S 120 NF 21

PRODUCT SERIES

CONNECTOR DESIGNATOR,  
H = MIL-DTL-38999  
SER, III & IV

ANGULAR FUNCTION,  
S = STRAIGHT  
W = 90°  
T = 45°  
WX = 90°, SPLIT OPTION  
TX = 45°, SPLIT OPTION

BASIC NO

FINISH SYM, TABLE II

SHELL SIZE, TABLE I

TABLE II

SYM	FINISH DESCRIPTION
B	CADMIUM PLATE/OLIVE DRAB
J	GOLD IRIDIUM OVER CADMIUM PLATE OVER NICKEL
M	ELECTROLESS NICKEL
N	CADMIUM PLATE/OLIVE DRAB OVER NICKEL
NF	CAD/O. D. OVER ELECTROLESS NICKEL (500 HOUR SALT SPRAY)
T	CADMIUM PLATE/BRIGHT DIP OVER NICKEL
Z1	300 SERIES STAINLESS STEEL, PASSIVATE, QQ-P-35
XM	ELECTROLESS NICKEL

BOEING ONLY  
5M2919, 5M2920, 5M2953

- NOTES:
- ASSEMBLY IDENTIFIED WITH MANUFACTURER'S NAME AND P/N, SPACE PERMITTING.
  - FOR EFFECTIVE GROUNDING, CONNECTOR WITH CONDUCTIVE FINISH SHOULD BE USED.
  - GLENRAIR 600 SERIES BACKSHELL ASSEMBLY TOOLS ARE RECOMMENDED FOR ASSEMBLY AND INSTALLATION.  
ACCOMMODATES 600-083 MICRO BAND.
  - MATERIAL/FINISH:  
COUPLING NUT - AL ALLOY, QQ-A-225/B ASTM B221 OR STAINLESS STEEL, QQ-S-763/ASTM B484 OR COMPOSITE/SEE TABLE II.  
STRAIN RELIEF - THERMOPLASTIC, PPS (RADEL-R5100, COLOR BLACK)

DRAWN	T. LE	04/21/03
ENGR	R. PAINTER	04/21/03
	T. YOUNG	04/21/03

UNLESS OTHERWISE SPECIFIED  
DIMENSIONS ARE IN INCHES  
TOLERANCES:

FRACTIONS ± 1/16  
DECIMALS .XX ± .03  
.XXX ± .015  
ANGLES ± 2°

DO NOT SCALE THIS DRAWING  
ORIGINAL DATE 11/02/07

NON REPARABLE COMMERCIAL ITEM

B/F 98-5746 P/C 44

SCALE N/A WEIGHT N/A SHEET 2 OF 2

REV. 06324 C 440H\*120 B

GLENRAIR, INC.  
1211 AIR WAY - GLENDALE - CALIFORNIA 91201

ADAPTER, BANDING, RFI/EMI,  
STRAIN RELIEF FOR MIL-DTL-38999  
SERIES III & IV CONNECTORS

CAD 2003

THIS COPYRIGHTED DOCUMENT IS THE PROPERTY OF GLENRAIR, INC. AND IS FURNISHED ON THE CONDITION THAT IT IS NOT TO BE DISCLOSED, REPRODUCED IN WHOLE OR IN PART, OR USED TO SOLICIT QUOTATIONS FROM COMPETITIVE SOURCES, OR USED FOR MANUFACTURE BY ANYONE OTHER THAN GLENRAIR, INC. WITHOUT WRITTEN PERMISSION FROM GLENRAIR, INC. THE INFORMATION HEREIN HAS BEEN DEVELOPED AT GLENRAIR'S EXPENSE AND MAY BE USED FOR ENGINEERING EVALUATION AND INCORPORATION INTO TECHNICAL SPECIFICATIONS AND OTHER DOCUMENTS WHICH SPECIFY PROCUREMENT OF PRODUCTS FROM GLENRAIR, INC.

# Mouser Electronics

Authorized Distributor

Click to View Pricing, Inventory, Delivery & Lifecycle Information:

## Glenair:

[440HS120NF19](#) [440HT120NF13](#) [440HT120NF25](#) [440HWX120NF15](#) [440HWX120NF23](#) [5M2919-1BW](#) [5M2919-3FW](#) [5M2919-3JW](#) [5M2920-3DW](#) [5M2920-3HW](#) [5M2953-3CW](#) [5M2953-3JW](#) [440HS120NF25](#) [440MS134NF0604K](#) [440MS134Z10705](#) [440MS134Z11411](#) [440FS120NF10](#) [440AS002NF1609-3N-X](#) [440HJ069NF1132](#) [440FS073M1608-2](#) [440FS030NF1604-3K](#) [440AJ086NF3220-AI](#) [440HWX120NF09](#) [440AA002NF1605-N-X](#) [440AD002NF0803-N-X](#) [440HJ069N0902](#) [440HS030M1706-2](#) [440HS002NF1108-3N-X](#) [440HS075NF1506-2B](#) [440HS120NF23](#) [440AS002NF2208-3N-X](#) [440HS039NF2106-2](#) [440HS039NF2107-2](#) [440FS002NF1210-3N-X](#) [440HS039NF1505-2](#) [440AS002NF2211-3N-X](#) [440HWX120NF17](#) [440AS030Z11002-2-157](#) [440HWX120NF19](#) [440AS002NF2010-3N-X](#) [440FJ030NF1402-K](#) [440HS002NF1904-3N-X](#) [440HT120NF19](#) [440AA002NF1611-N-X](#) [440HS045M1504-3](#) [440HT120NF23](#) [440AS002NF1409-3N-X](#) [440DJ031NF1404-B](#) [440HA002NF1105-N-X](#) [440AS002NF2411-3N-X](#) [440AJ031NF1433-B](#) [440AJ086NF1808-AI](#) [440AS039NF0801-2](#) [440FS031NF1632-3K](#) [440HS039M1304-2](#) [440AA002NF2211-N-X](#) [440FS120NF14](#) [440HS045M2308-3](#) [440HD002NF1710-N-X](#) [440HS045M1103-3](#) [440FS044M08](#)