

- 注記 :
NOTES :
- ① 材料及び仕上げ(めっき仕様) : TABLE 1, TABLE2 参照
MATERIAL AND FINISHES (PLATING SPECIFICATION) : SEE TABLE 1, TABLE2.
 - ② 製品仕様書、コネクタ取扱説明書、適合嵌合相手はSHEET 5をご参照下さい。
PLEASE REFER TO SHEET 5 FOR PRODUCT SPECIFICATION, APPLICATION SPECIFICATION AND MATE WITH.
 3. 端子テール部 及び ネイルの平坦度 : 0.12 MAXIMUM
TAIL AND NAIL COPLANARITY TO BE 0.12 MAXIMUM
 - ④ 極数 / 2 = 偶数に適合
APPLY TO CIRCUIT SIZE / 2 = EVEN.
 - ⑤ 発注番号 : 製品一覧参照
ORDER NUMBER : PLEASE REFER TO ORDER NUMBER LIST

505433****

番号 NO.	カバーテープ COVER TAPE	極数 CIRCUIT SIZE	ハウジングカラー HOUSING COLOR
0	無 WITHOUT	2	ナチュラル(ベージュ) NATURAL(BEIGE)
1	有 WITH	4	黒 BLACK
2	有 WITH	6	赤 RED
4	有 WITH	8	青 BLUE
6	有 WITH	10	緑 GREEN

29.4	25	30.85	42
28.15	23.75	29.6	40
26.9	22.5	28.35	38
25.65	21.25	27.1	36
24.4	20	25.85	34
23.15	18.75	24.6	32
21.9	17.5	23.35	30
20.65	16.25	22.1	28
19.4	15	20.85	26
18.15	13.75	19.6	24
16.9	12.5	18.35	22
15.65	11.25	17.1	20
14.4	10	15.85	18
13.15	8.75	14.6	16
11.9	7.5	13.35	14
10.65	6.25	12.1	12
9.4	5	10.85	10
8.15	3.75	9.6	8
C	B	A	極数 CIRCUIT SIZE

① TABLE 1

番号 NO.	部品 PART	材質 MATERIAL
①	ハウジング HOUSING	ポリアミド(PA) UL94V-0 色 : 注記6参照 POLY AMIDE(PA) UL94V-0 COLOR : SEE NOTE 6
②	ターミナル及びネイル TERMINAL AND NAIL	黄銅 BRASS 錫ビスマスめっき : 1.0 MICROMETER MINIMUM TIN-BISMUTH PLATING ニッケルめっき(下地) : 1.0 MICROMETER MINIMUM NICKEL (UNDER PLATING)
④	カバーテープ COVER TAPE	ポリイミド POLYIMIDE

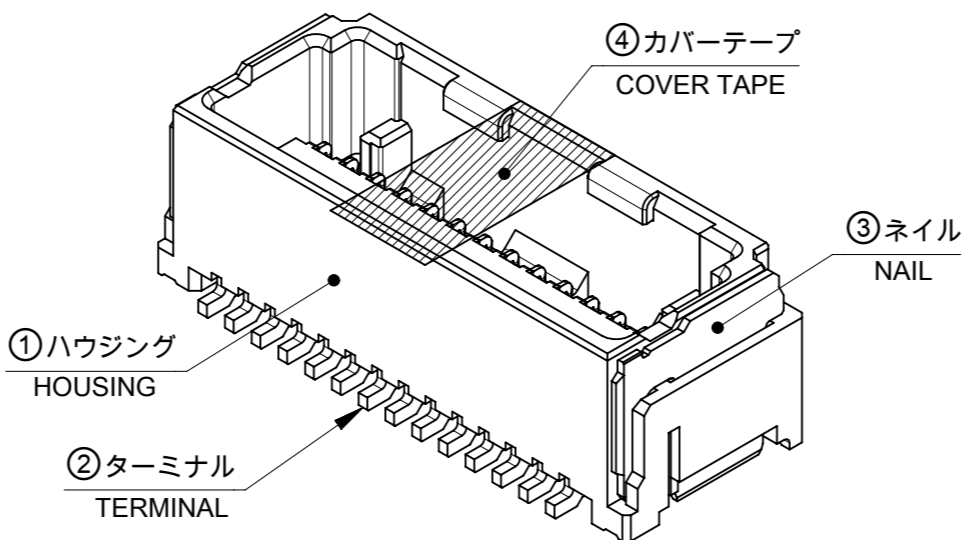

THIS DRAWING CONTAINS INFORMATION THAT IS PROPRIETARY TO MOLEX ELECTRONIC TECHNOLOGIES, LLC AND SHOULD NOT BE USED WITHOUT WRITTEN PERMISSION		CURRENT REV DESC:			
DIMENSION UNITS	SCALE	EC NO: 720259			
mm	NTS	DRWN: SOKUMURA01 2022/11/09		MICRO-LOCK PLUS 1.25 W/B DUAL ROW VERTICAL SMT PLUG ASSEMBLY TIN-BISMUTH PLATING	
GENERAL TOLERANCES (UNLESS SPECIFIED)		CHK'D: SAKIYAMA 2022/11/28			
ANGULAR TOL ± 3.0°		APPR: AIDA 2022/11/30		PRODUCT CUSTOMER DRAWING	
4 PLACES	± 0.2	INITIAL REVISION:		DOCUMENT NUMBER	
3 PLACES	± 0.2	DRWN: TAKAIKE 2016/12/26		5054330000	
2 PLACES	± 0.2	APPR: TKANEKO 2016/12/28		PSD 000 D	
1 PLACE	± 0.2	DRAFT WHERE APPLICABLE MUST REMAIN WITHIN DIMENSIONS		DOC TYPE DOC PART REVISION	
0 PLACES	± 0.2	THIRD ANGLE PROJECTION		MATERIAL NUMBER CUSTOMER SHEET NUMBER	
DRAWING		SERIES		SEE SHEET 5 GENERAL 1 OF 5	
A3-SIZE		505433			

製品形状
PRODUCT SHAPE

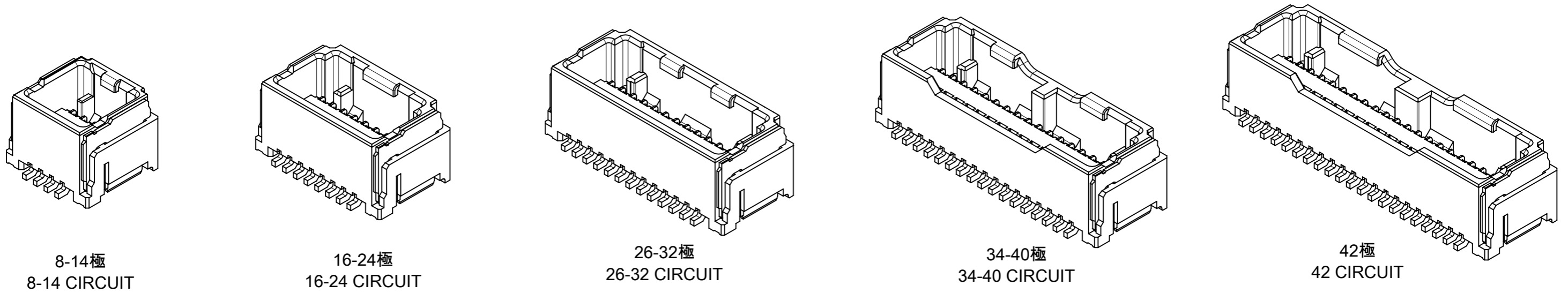

基板パターンレイアウト
PCB PATTERN LAYOUT

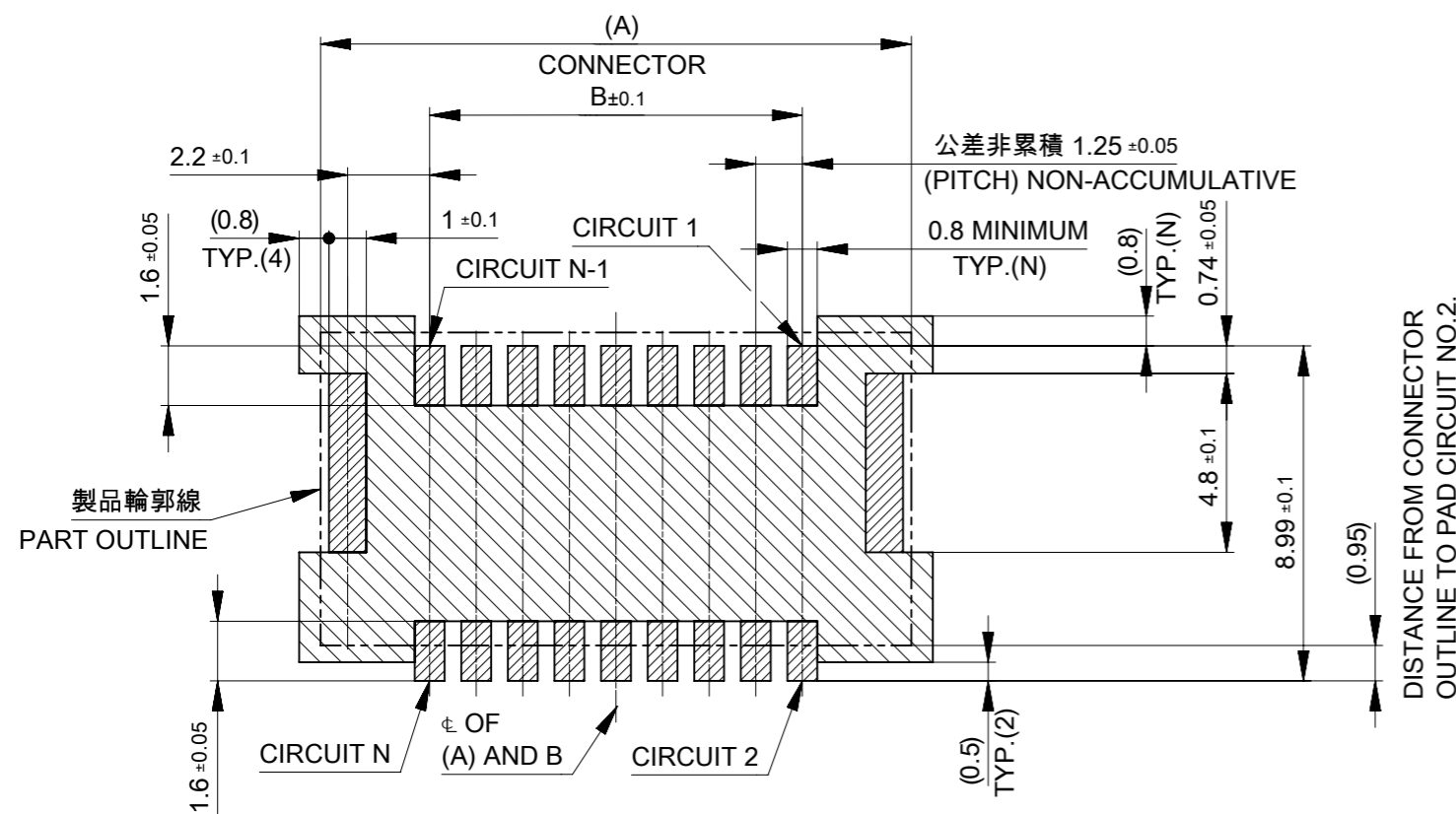

基板パターンレイアウト (参考)
(参考: 基板厚 1.6mm, メタルマスク厚さ 0.15mm, マスク開口率 100%)
RECOMMEND PCB LAYOUT : COMPONENT SIDE
(REFERENCE : PCB THICKNESS 1.6mm, STENCIL THICKNESS 0.15mm, APERTURE RATIO 100%)

パターン非推奨エリア
パターンを引き回す際は、製品機能に影響がないことをご確認ください。
PATTERN IS NOT RECOMMENDED ON THE HATCHING AREA
PLEASE CHECK NOT TO HAVE PROBLEM FOR PRODUCT FUNCTION
WHEN SETTING PATTERN ON THE HATCHING AREA.

THIS DRAWING CONTAINS INFORMATION THAT IS PROPRIETARY TO MOLEX ELECTRONIC TECHNOLOGIES, LLC AND SHOULD NOT BE USED WITHOUT WRITTEN PERMISSION		CURRENT REV DESC:		molex	
DIMENSION UNITS	SCALE				
mm	NTS			MICRO-LOCK PLUS 1.25 W/B DUAL ROW VERTICAL SMT PLUG ASSEMBLY TIN-BISMUTH PLATING	
GENERAL TOLERANCES (UNLESS SPECIFIED)				PRODUCT CUSTOMER DRAWING	
ANGULAR TOL	± 3.0 °			DOCUMENT NUMBER	
4 PLACES	± 0.2	EC NO: 720259	2022/11/09	5054330000	
3 PLACES	± 0.2	DRWN: SOKUMURA01	2022/11/28	DOC TYPE	DOC PART
2 PLACES	± 0.2	CHK'D: SAKIYAMA	2022/11/30	PSD	000
1 PLACE	± 0.2	APPR: AIDA		REVISION	D
0 PLACES	± 0.2	INITIAL REVISION:		SHEET NUMBER	
DRAFT WHERE APPLICABLE MUST REMAIN WITHIN DIMENSIONS		DRWN: TAKAIKE	2016/12/26	2 OF 5	
THIRD ANGLE PROJECTION		APPR: TKANEKO	2016/12/28		
DRAWING		SERIES	MATERIAL NUMBER	CUSTOMER	
A3-SIZE		505433	SEE SHEET 5	GENERAL	

吸着エリア違い
SUCTION AREA DIFFERNECE

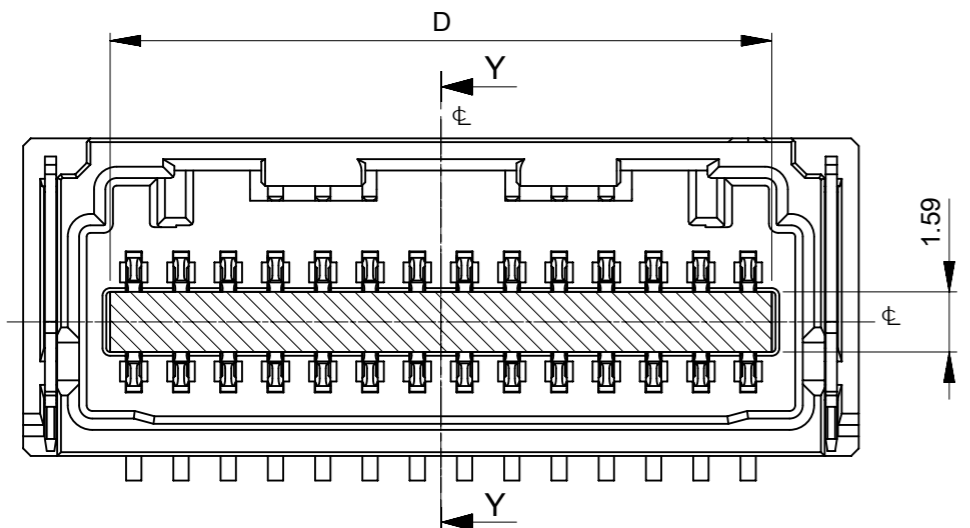

505433 **7*
カバーテープ無し
WITHOUT COVER TAPE

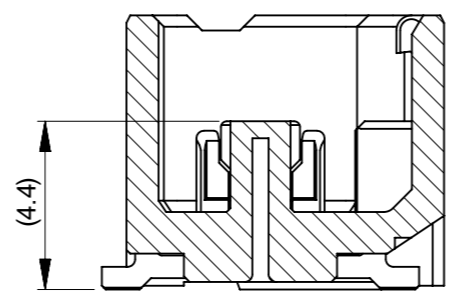

SECTION Y-Y
吸着高さ SUCTION HEIGHT

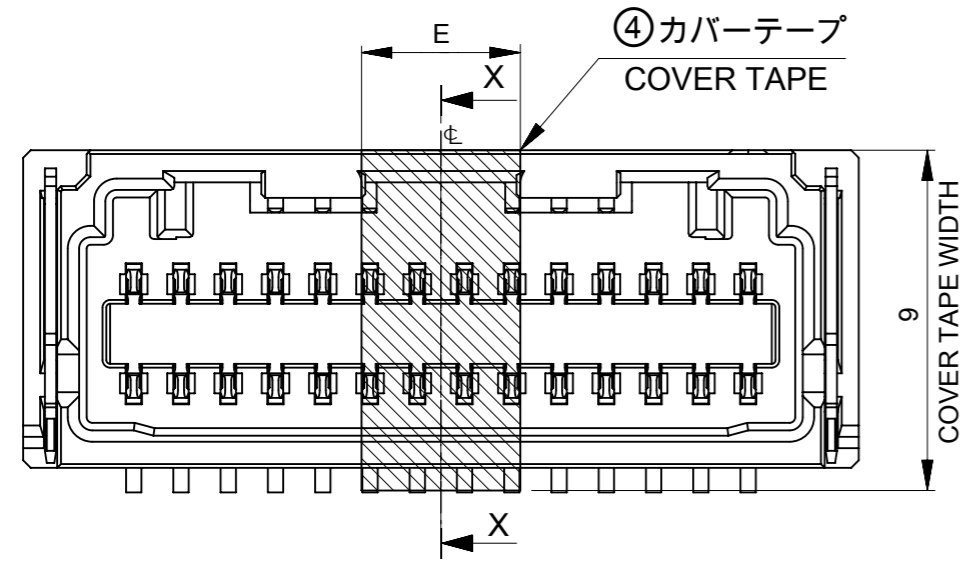

505433 **8*
カバーテープ有り
WITH COVER TAPE

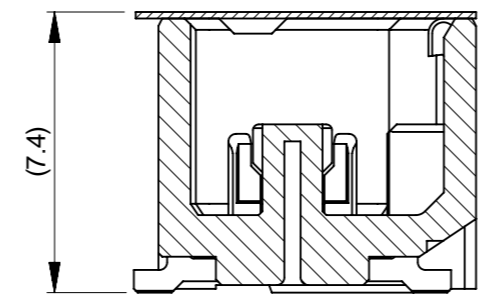

8-32極
8-32 CIRCUIT

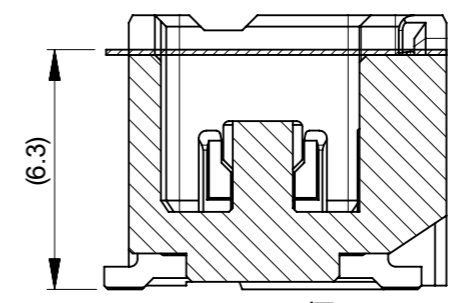

34-42極
34-42 CIRCUIT

SECTION X-X
吸着テープ高さ COVER TAPE HEIGHT

4.2	5	26.25	42
		25	40
		23.75	38
		22.5	36
		21.25	34
		20	32
		18.75	30
		17.5	28
		16.25	26
		15	24
		13.75	22
		12.5	20
		11.25	18
		10	16
	8.75	14	
	7.5	12	
	6.25	10	
	5	8	
E	D	極数 CIRCUIT SIZE	

THIS DRAWING CONTAINS INFORMATION THAT IS PROPRIETARY TO MOLEX ELECTRONIC TECHNOLOGIES, LLC AND SHOULD NOT BE USED WITHOUT WRITTEN PERMISSION									
DIMENSION UNITS mm		SCALE NTS		CURRENT REV DESC:				molex	
GENERAL TOLERANCES (UNLESS SPECIFIED)		ANGULAR TOL ± 3.0°		EC NO: 720259 DRWN: SOKUMURA01 2022/11/09 CHK'D: SAKIYAMA 2022/11/28 APPR: AIDA 2022/11/30					
4 PLACES ± 0.2		3 PLACES ± 0.2		INITIAL REVISION:				DOCUMENT NUMBER	
2 PLACES ± 0.2		1 PLACE ± 0.2		DRWN: TAKAIKE 2016/12/26 APPR: TKANEKO 2016/12/28				5054330000	
0 PLACES ± 0.2		DRAFT WHERE APPLICABLE MUST REMAIN WITHIN DIMENSIONS		THIRD ANGLE PROJECTION		DRAWING A3-SIZE		SERIES 505433	
MATERIAL NUMBER SEE SHEET 5		CUSTOMER GENERAL		SHEET NUMBER 3 OF 5		DOC TYPE PSD		DOC PART 000	
REVISION D		DATE 2022/11/30		DRAWN TAKAIKE		CHECKED SAKIYAMA		APPROVED AIDA	

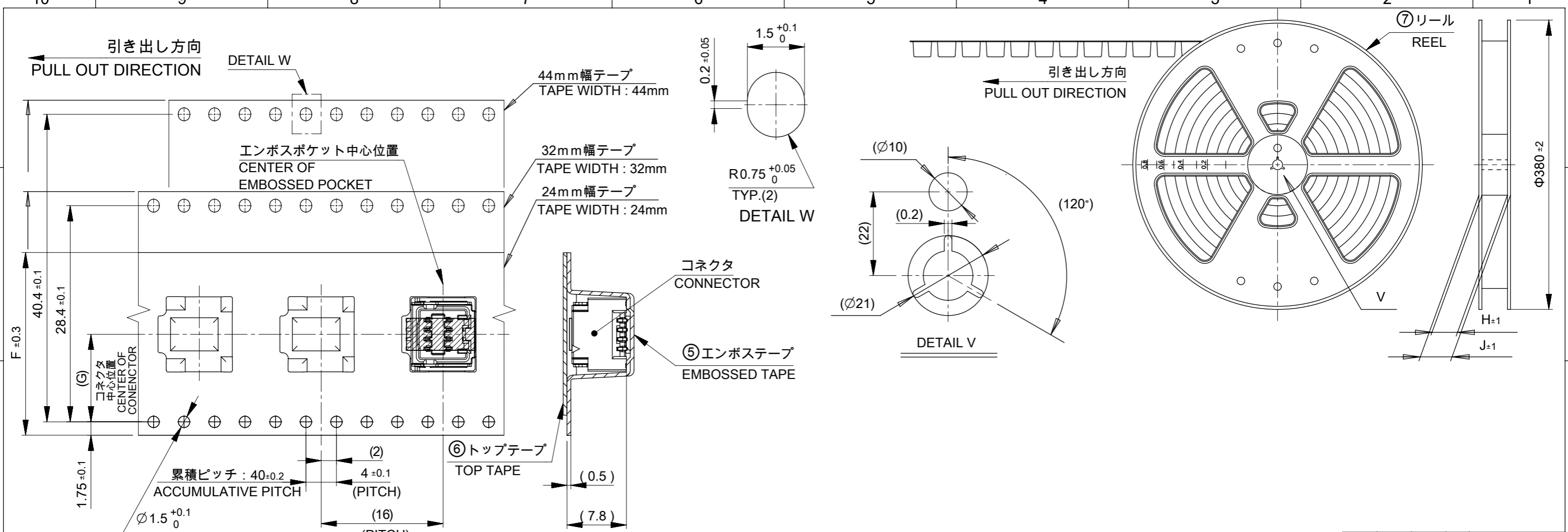

NOTES

- 6. 梱包数量 : 500個
NUMBER OF CONNECTORS : 500 PIECES/REEL.
- 7. リードテープ長さ
LEAD TAPE LENGTH

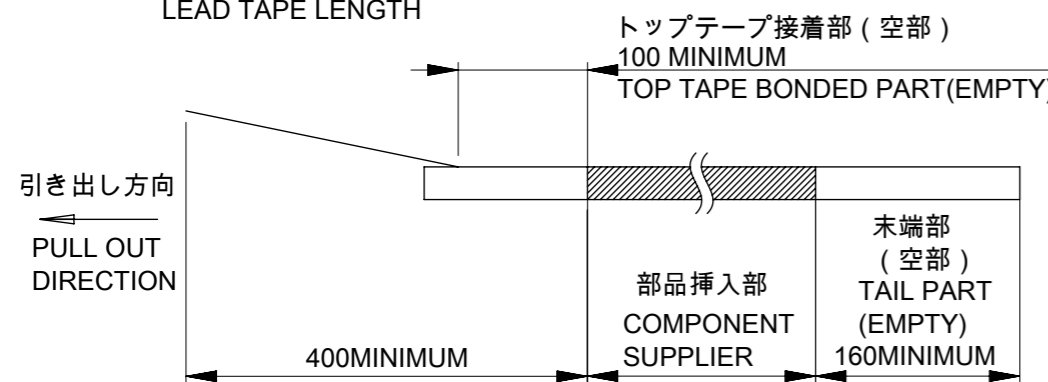

8. トップテープの剥離強度については、IEC60286-3に準拠
TOP TAPE PEEL FORCE IS DEFINED BY IEC 60286-3.

TABLE 2

番号 NO.	部品 PART	材質 MATERIAL
⑤	エンボステープ EMBOSSED TAPE	ポリスチレン(PS) POLYSTYRENE(PS)
⑥	トップテープ TOP TAPE	ポリエチレン(PE)、その他 POLYETHYLENE(PE), OTHER
⑦	リール REEL	ポリスチレン(PS) <リサイクル材を含む> POLYSTYRENE(PS) <RECYCLE MATERIAL CONTAINED >

DOCUMENT STATUS	P1	RELEASE DATE	2022/11/30	03:03:16
-----------------	----	--------------	------------	----------

49.4	45.4	20.2	44	42
				40
				38
				36
37.4	33.4	14.2	32	34
				32
				30
				28
29.4	25.4	11.5	24	26
				24
				22
				20
J	H	G	F	18
				16
				14
				12
				10
				8
				極数 CIRCUIT SIZE

THIS DRAWING CONTAINS INFORMATION THAT IS PROPRIETARY TO MOLEX ELECTRONIC TECHNOLOGIES, LLC AND SHOULD NOT BE USED WITHOUT WRITTEN PERMISSION

DIMENSION UNITS mm	SCALE NTS	CURRENT REV DESC:	
GENERAL TOLERANCES (UNLESS SPECIFIED)		<p>molex</p> <p>MICRO-LOCK PLUS 1.25 W/B DUAL ROW VERTICAL SMT PLUG ASSEMBLY TIN-BISMUTH PLATING</p> <p>PRODUCT CUSTOMER DRAWING</p>	
ANGULAR TOL	± 3.0 °		
4 PLACES	± 0.2		
3 PLACES	± 0.2		
2 PLACES	± 0.2		
1 PLACE	± 0.2	EC NO: 720259 DRWN: SOKUMURA01 2022/11/09 CHK'D: SAKIYAMA 2022/11/28 APPR: AIDA 2022/11/30	
0 PLACES	± 0.2	INITIAL REVISION: DRWN: TAKAIKE 2016/12/26 APPR: TKANEKO 2016/12/28	
DRAFT WHERE APPLICABLE MUST REMAIN WITHIN DIMENSIONS		THIRD ANGLE PROJECTION	DRAWING
		SERIES	MATERIAL NUMBER
		A3-SIZE	505433
		CUSTOMER	SEE SHEET 5
		DOCUMENT NUMBER	5054330000
		DOC TYPE	PSD
		DOC PART	000
		REVISION	D
		SHEET NUMBER	4 OF 5

△ 適合製品及び各種仕様書 APPLICABLE PRODUCTS AND VARIOUS SPECIFICATIONS

梱包仕様書 PACKAGING SPECIFICATION		5054339200 PS 200	
適合嵌合相手 MATE WITH	シリーズ番号 SERIES NUMBER	505432	214527
	リテーナー対応 RETAINER COMPLIANT	NOT COMPLIANT	COMPLIANT (NATURAL, BLACK, RED, BLUE)
製品仕様書 PRODUCT SPECIFICATION		5054320000 PS 002	2145270000-PS PS 000
コネクタ取扱説明書 APPLICATION SPECIFICATION		5054320000-AS PS 000	

嵌合状態図
MATED CONNECTORS

△ 嵌合相手 : 505432シリーズ
MATE WITH : 505432 SERIES

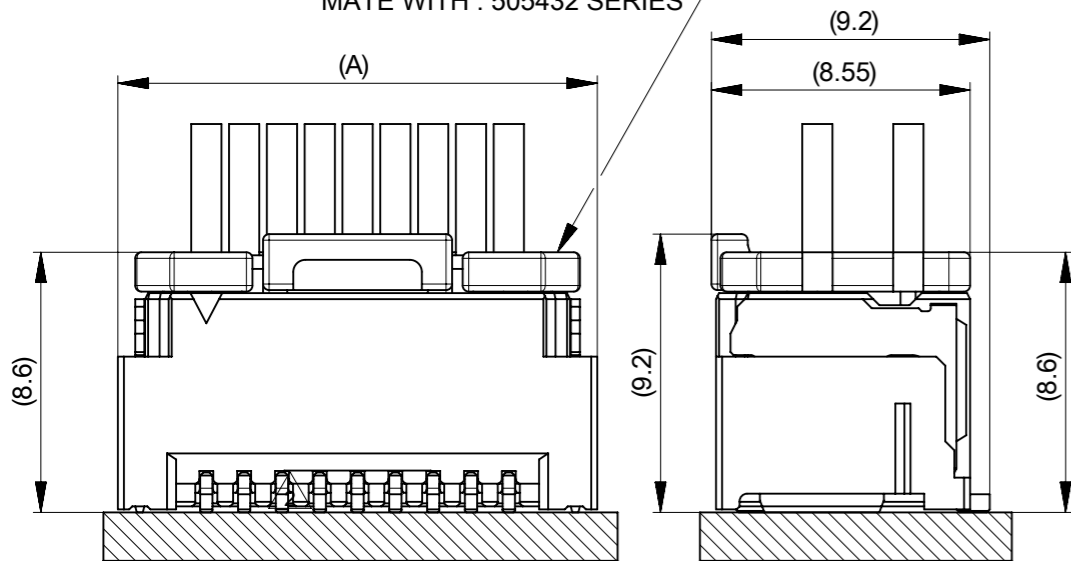

△ 嵌合相手 : 214527シリーズ
MATE WITH : 214527 SERIES

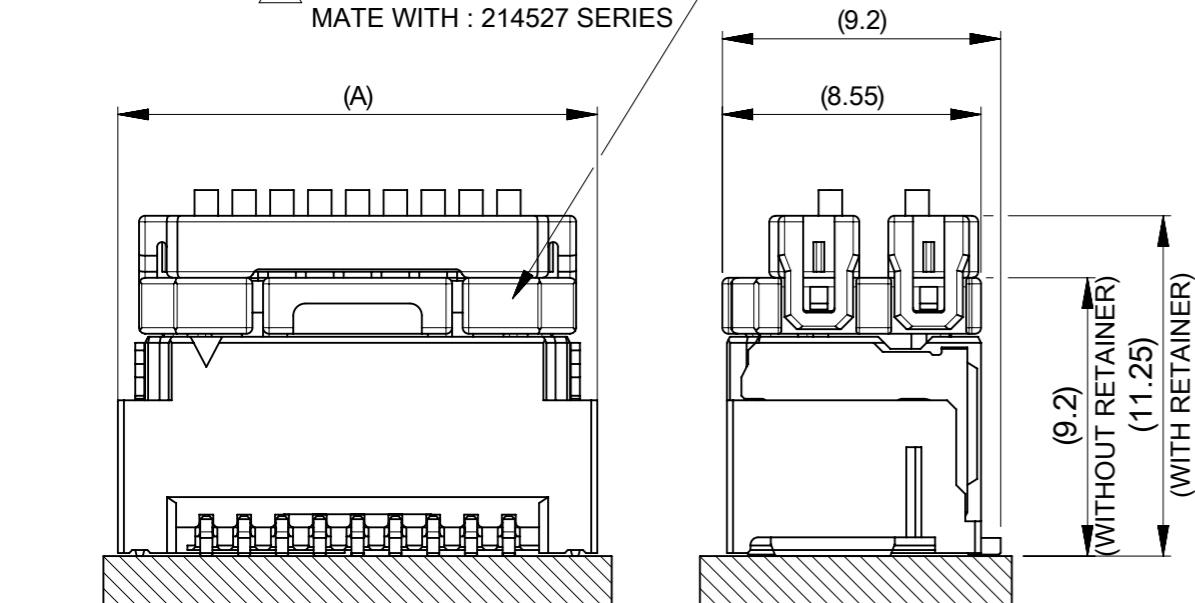

△ 製品一覧 PRODUCT LIST

WITHOUT					WITH					COVER TAPE
GREEN	BLUE	RED	BLACK	NATURAL (BEIGE)	GREEN	BLUE	RED	BLACK	NATURAL (BEIGE)	HOUSING COLOR
5054334276	5054334274	5054334272	5054334271	5054334270	5054334286	5054334284	5054334282	5054334281	5054334280	42
5054334076	5054334074	5054334072	5054334071	5054334070	5054334086	5054334084	5054334082	5054334081	5054334080	40
5054333876	5054333874	5054333872	5054333871	5054333870	5054333886	5054333884	5054333882	5054333881	5054333880	38
5054333676	5054333674	5054333672	5054333671	5054333670	5054333686	5054333684	5054333682	5054333681	5054333680	36
5054333476	5054333474	5054333472	5054333471	5054333470	5054333486	5054333484	5054333482	5054333481	5054333480	34
5054333276	5054333274	5054333272	5054333271	5054333270	5054333286	5054333284	5054333282	5054333281	5054333280	32
5054333076	5054333074	5054333072	5054333071	5054333070	5054333086	5054333084	5054333082	5054333081	5054333080	30
5054332876	5054332874	5054332872	5054332871	5054332870	5054332886	5054332884	5054332882	5054332881	5054332880	28
5054332676	5054332674	5054332672	5054332671	5054332670	5054332686	5054332684	5054332682	5054332681	5054332680	26
5054332476	5054332474	5054332472	5054332471	5054332470	5054332486	5054332484	5054332482	5054332481	5054332480	24
5054332276	5054332274	5054332272	5054332271	5054332270	5054332286	5054332284	5054332282	5054332281	5054332280	22
5054332076	5054332074	5054332072	5054332071	5054332070	5054332086	5054332084	5054332082	5054332081	5054332080	20
5054331876	5054331874	5054331872	5054331871	5054331870	5054331886	5054331884	5054331882	5054331881	5054331880	18
5054331676	5054331674	5054331672	5054331671	5054331670	5054331686	5054331684	5054331682	5054331681	5054331680	16
5054331476	5054331474	5054331472	5054331471	5054331470	5054331486	5054331484	5054331482	5054331481	5054331480	14
5054331276	5054331274	5054331272	5054331271	5054331270	5054331286	5054331284	5054331282	5054331281	5054331280	12
5054331076	5054331074	5054331072	5054331071	5054331070	5054331086	5054331084	5054331082	5054331081	5054331080	10
5054330876	5054330874	5054330872	5054330871	5054330870	5054330886	5054330884	5054330882	5054330881	5054330880	8

発注番号 ORDER NUMBER

エンボステープ梱包
PACKAGING STYLE : EMBOSSED TAPE AND REEL

極数
CIRCUIT SIZE

THIS DRAWING CONTAINS INFORMATION THAT IS PROPRIETARY TO MOLEX ELECTRONIC TECHNOLOGIES, LLC AND SHOULD NOT BE USED WITHOUT WRITTEN PERMISSION

DIMENSION UNITS mm	SCALE NTS	CURRENT REV DESC:		molex		
GENERAL TOLERANCES (UNLESS SPECIFIED)		EC NO: 720259				
ANGULAR TOL ± 3.0°	4 PLACES ± 0.2	DRWN: SOKUMURA01 2022/11/09		PRODUCT CUSTOMER DRAWING		
2 PLACES ± 0.2	3 PLACES ± 0.2	CHK'D: SAKIYAMA 2022/11/28		DOCUMENT NUMBER		
1 PLACE ± 0.2	2 PLACES ± 0.2	APPR: AIDA 2022/11/30		5054330000		
0 PLACES ± 0.2	1 PLACE ± 0.2	INITIAL REVISION:		DOC TYPE DOC PART REVISION		
DRAFT WHERE APPLICABLE MUST REMAIN WITHIN DIMENSIONS	DRWN: TAKAIKE 2016/12/26	APPR: TKANEKO 2016/12/28		PSD 000 D		
THIRD ANGLE PROJECTION	DRAWING	SERIES	MATERIAL NUMBER	CUSTOMER		SHEET NUMBER
	A3-SIZE	505433	SEE CHART	GENERAL		5 OF 5