

BTX-208

Fume Extraction System



System User Guide

	page
For Your Safety	2
Items Supplied	2
Description	2
Installation	2
Operation and Maintenance	2
Maintenance	2
Troubleshooting	3
Technical Data	3
Part Numbers	4
Warranty	4
Contact Information	4



For Your Safety

For safe and successful operation of the unit, read these instructions completely. If the instructions are not observed, the manufacturer can assume no responsibility. Retain this manual for future reference.

Always disconnect the power supply before servicing the unit.

Do not operate the Unit without filter inserts. Contaminants in the extracted air will damage the blower. Use only original equipment filters.

The BVX-208 is designed for the removal of solder fumes. Use filter unit only for this purpose. Consult your "safety department" when using the unit on flammable gases. This unit is not explosion safe and can only be used for the extraction of vapors, which have concentration levels well below the lower explosive limits.

This system is equipped with automatic reset overload protection, which may cause the unit to restart automatically.

While under warranty, the unit may be repaired only by an authorized Metcal Service Representative.

Items Supplied

- 1 Filter Unit with filters installed
- 1 32mm hose adapter
- 1 air inlet cover installed on second air inlet port
- 1 Power Cord
- 1 Operating Manual

Description

- (1) ON/OFF switch
- (2) Power Output
- (3) 32mm hose adapter
- (4) air inlet cover with bypass valve
- (5) latch (front and back)

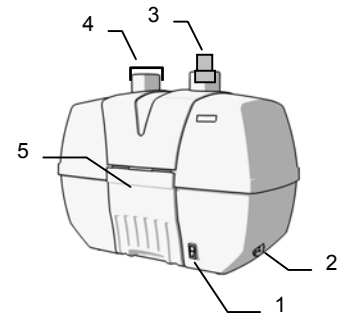

Installation

- Place filter unit (1) at a location which minimizes length of ducting
- Screw supplied hose adapter into open air inlet port (2)
- Install ducting (3) as per *duct installation instructions*
- Install iron adapter kits (4)
- Connect filter unit to power supply (5)

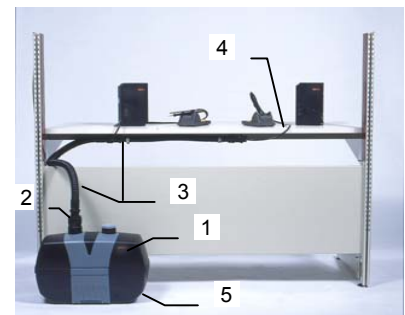

Operation and Maintenance

- Turn unit ON.
- Check if the motor pump indicates an acoustical "fluttering" effect. If yes, open air by-pass valve on air inlet cover until "fluttering" sound disappears. Do not open too much as this will reduce the airflow performance. The "fluttering" does not cause any damage to the system.

Air inlet cover
with bypass
valve

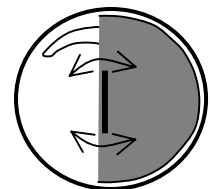

Maintenance

The airflow of the filter unit decreases during operation due to several reasons:

- Clogging of vacuum tubes and hoses attached to solder iron
- Saturation of pre and main-filter inside filter unit

Tip Extraction Accessories:

Clean stainless steel vacuum tubes (1) periodically and frequently. Cleaning brushes are supplied with the iron adapter kits. Inspect vacuum hoses (2) visually and clean if needed.



Replacement of filters:

If, after cleaning of accessories, the fumes are not extracted efficiently, replace filter(s) inside filter unit. Initially replace the pre-filter only. If this step does not sufficiently improve the airflow, then replace the main filter (HEPA/Carbon).

1. Turn unit off.
2. Disconnect the power cord.
3. Unlatch the filter cover (1).
4. Remove filter cover.
5. Replace the filters. (Pre-filter/main filter). Make sure to place main filter inside the alignment pins (2) so that interlock switch (3) is depressed.
6. Replace filter cover and ensure proper fit on bottom housing. Hook both latches into filter cover and press down carefully.
7. Reconnect power cord and turn system on.
8. If unit does not operate, refer to troubleshooting section.

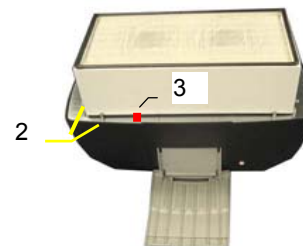

⚠ Caution! Do not use force. If latches do not close, check proper seating of filter cover on bottom housing.

Notice: Always use new replacement filters!

For disposal of used filters follow local environmental and safety requirements.

Troubleshooting

Problem	Possibly Cause	Solution
No air flow	No Power Interlock switch open	Check On/Off Switch Check power outlet Check power cord Check filter Check safety interlock switch
Little air flow	Clogged tubes / hoses Air leak	Clean extraction tube at solder iron Clean vacuum hoses Check duct connections for leaks Housing not closed correctly

Technical Data

Max. number of stations	8
Flow rate per station	> 28 lit/min
Noise Level:	< 55 dBA
Dimensions (WxDxH)	508 x 254 x 388 mm
Weight:	9 kg (20 lbs)
Voltage	100-240 VAC
Frequency	50 – 60 Hz
Power	85 Watt
Certification	UL / CSA / CE

Part Numbers

BTX-208 Filter Unit tip extraction for 8 stations, 100-240V / 50-60Hz

Replacement Filters

FP-BVX200 Pre-filter (Pack of 5)

FM-BVX200 Main filter, HEPA 99.95% / Carbon

Duct Connection Kits

BTX-CK2-25 Hose connection kit 2-4 stations 2.5m (8') long

BTX-CK4-50 Hose connection kit 4-8 stations 5m (16') long

BTX-CK4-75 Hose connection kit 2-4 stations 7.5m (25) long

For Iron Adapter Kits contact your OK International Sales Representative.

Warranty

OK International warrants the BTX-208 system against any defects in materials or workmanship for one (1) year from the date of purchase by the original owner. This Warranty excludes normal maintenance and shall not apply to any opened, misused, abused, altered or damaged items. If the product should become defective within the warranty period, OK International will repair or replace it free of charge at its sole option. The repaired or replacement item(s) will be shipped, freight prepaid, to the original purchaser. The warranty period will start from the date of purchase. If the date of purchase cannot be substantiated the date of manufacture will be used as the start of the warranty period.

For the repair or return of a unit, a Return Material Authorization Number (RMA #) needs to be obtained.

Contact Information

For Sales & Customer Care

<p>North America OK International 12151 Monarch Street Garden Grove, CA 92841 USA Tel: +1 714-799-9910 Fax: +1 714-799-9533</p>	<p>France OK International SA Rue de la Saone Zac De Follieuses-Les Echets 01706 Miribel Cedex France Tel: +33 (0) 4 72 26 20 30 Fax: +33 (0) 4 72 26 20 35</p>	<p>Singapore OK International (Sales Support Office) 10 Ang Mo Kio St.65 #03-18/19 Techpoint Singapore 569059 Tel: +65-62810991 Fax: +65-62853473</p>
<p>United Kingdom OK International Ltd. Eagle Close, Chandlers Ford Hampshire, SO53 4NF U.K. Tel: +44 (0) 23 8048 9100 Fax: +44 (0) 23 8048 9109</p>	<p>Germany OK International GmbH Frankfurter Strasse 74 D-64521 Gross-Gerau Germany Tel: +49 (0) 61 52-71 12-0 Fax: +49 (0) 61 52-71 12-22</p>	<p>China OK Electronics (Beijing) Co., Ltd No. 1 Bldi, A-10 Long Qing Street Beijing Econ. & Tech. Developing Zone Beijing, 100176 P.R. China Tel: +86-10-67878490 Fax: +86-10-67878491</p>
	<p>Italy OK International Strada Statale 11 – No. 28, 20010 Vittuone (Milano) Italy Tel: +39 02 9025161 Fax: +39 02 90111147</p>	<p>Japan OK International Japan Co. 5-3-1 Heiwajima, Ota-ku Tokyo 143-0006 Japan Tel: +81-3-5753-0085 Fax: +81-3-3765-8855</p>