

REVISIONS						
ZONE	REV.	ECN	DESCRIPTION	BY	DATE	APPROVED
	A	DDYR-A3AQU6.VER01	NEW RELEASE		10/15/2015	DC
	B	DDYR-A8KPVD.VER01	REVISED TITLE BLOCK	DC	3/31/2016	DC
	C	DDYR-18092102	ADDED -C104 TO TABLE 1. HCL-SH		09/27/2018	JM

AHSP P/N	LENGTH "A"	CUSTOMER P/N
NDAAFF-C101	1000 ±20	SF-NDAAFF100G-001M
NDAAFF-C102	2000 ±40	SF-NDAAFF100G-002M
NDAAFF-C103	3000 ±60	SF-NDAAFF100G-003M
NDAAFF-C104	500 ±20	SF-NDAAFF100G-000.5M

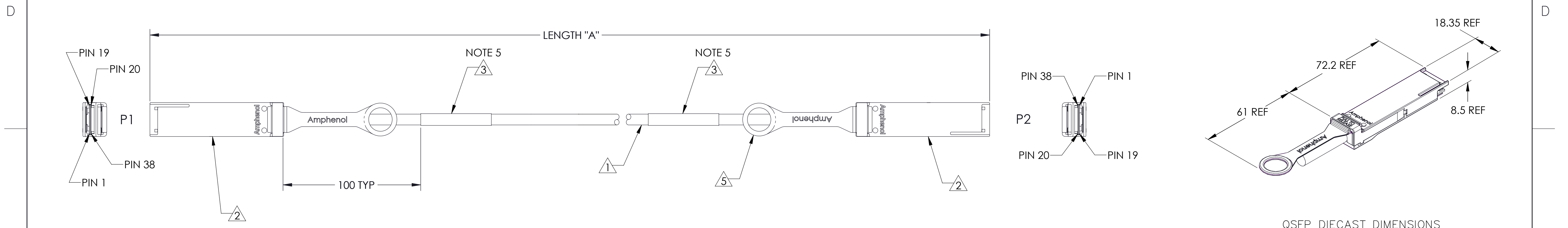

ITEM No.	DESCRIPTION
①	30 AWG, 8-PR, PVC BLACK, UL AWM STYLE 20276, 80°C, VW1
②	PLUG, QSFP+, REFERENCE SFF-8661
③	LABEL, WRAPPED - AHSP P/N, REV, DATE CODE, LENGTH, COO & SERIAL NUMBER
⑤	LANYARD - PANTONE 347C (GREEN)

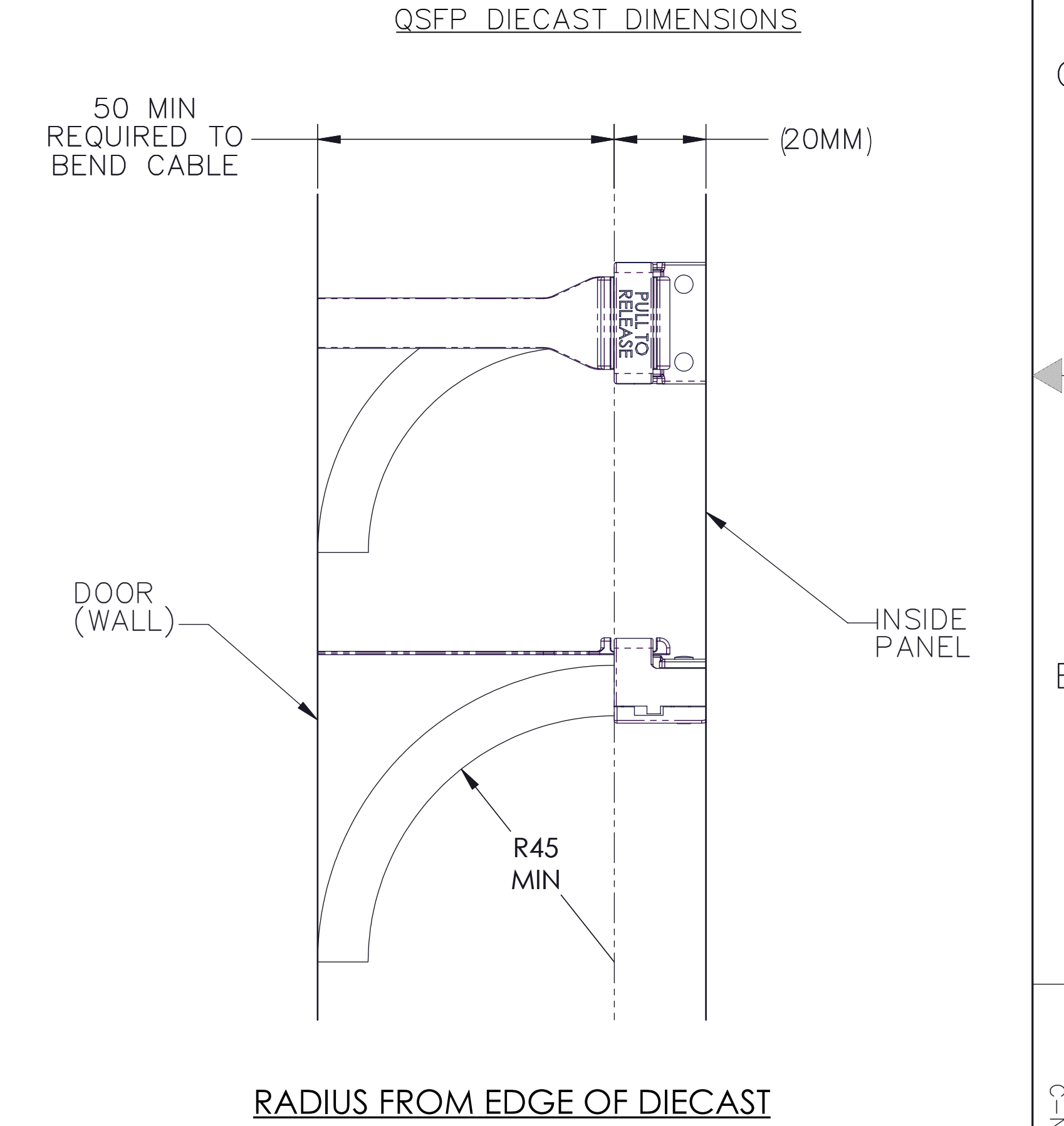
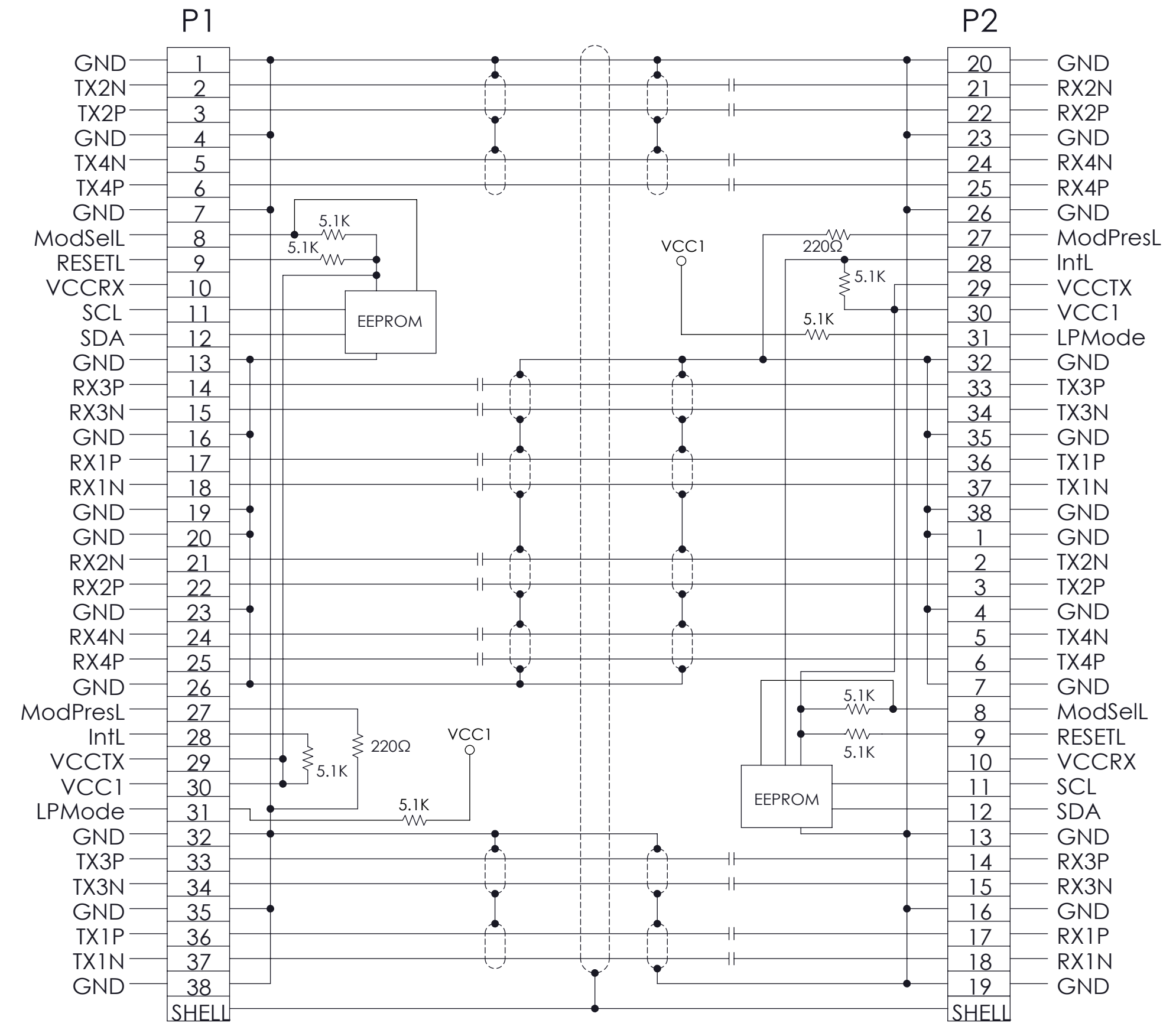

- UL LABEL MUST BE ON THE SHIPPING CARTON PER SUBJECT 764 OF THE UL COMPONENT WIRING HARNESS (ZPFW2) FILE #E86140. CSA LABEL MUST BE ON SHIPPING CARTON.
  - PACKAGE COMPLETED ASSY IN AN APPROPRIATELY SIZED ESD BAG.
  - EPROM CONTENT SHALL BE COMPLIANT WITH SFF-8636 SPECIFICATIONS FOR 100GBASE-CR4. EPROM REVISION IS EQUAL TO AHSP PART NUMBER REVISION.
  - ASSEMBLIES LESS THAN ONE METER REQUIRE ONLY ONE LABEL PLACED ON P1 END.
  - CABLE ASSEMBLIES MUST MEET SHIELDING EFFECTIVENESS REQUIREMENTS OF 35dB FROM 1-10GHz AND 30dB FROM 10-18GHz.
  - COMPLIANT TO EU DIRECTIVE 2011/65/EU - RoHS2.
  - ASSEMBLIES SHALL BE COMPLIANT TO 100GBASE-CR4 SPECIFICATION (EXCEPT NDAAFF-0005).
  - THIS DRAWING IS RESERVED FOR AMPHENOL CABLES ON DEMAND.
- NOTES: UNLESS OTHERWISE SPECIFIED

NOTE: DC BLOCKING CAP VALUE IS 0.1 μF  
EPROM CONNECTED TO VCCTX

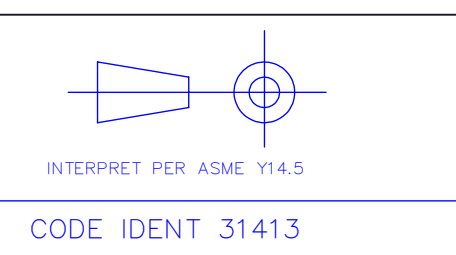

TOLERANCES	DWN	CHK	APVD	EM	Amphenol AHSP	
0.0	± 0.25	DC	10/13/2015		A Division of Amphenol Corporation	
0.00	± 0.08	DD	10/13/2015		200 Innovative Way, Suite 201, Nashua, N.H. 03062 (603) 879-3000	
0.000	-		10/13/2015		TITLE CABLE ASSEMBLY, QSFP/QSFP, PSV, 100Ω, 100 GbE, 30 AWG EXD	
ANGLES	± 1.0°				UNLESS OTHERWISE SPECIFIED DIMENSIONS ARE IN MM	
CUSTOMER USE DRAWING					PART NO.	SEE TABLE 1
					DRAWING NO.	C-NDAAFF-C199
					REV	N/A
					REV	C
SIZE	D	SCALE	1:1	SHEET	1	OF 1

# Mouser Electronics

Authorized Distributor

Click to View Pricing, Inventory, Delivery & Lifecycle Information:

[Amphenol:](#)

[SF-NDAAFF100G-003M](#) [SF-NDAAFF100G-002M](#) [SF-NDAAFF100G-001M](#)