

REVISION		
REV	DESCRIPTION	APPROVED
A1	REVISED DWG PER ECO-17-004936	A.REY
A2	REVISED NOTE 7 PER ECO-17-008496	A.REY

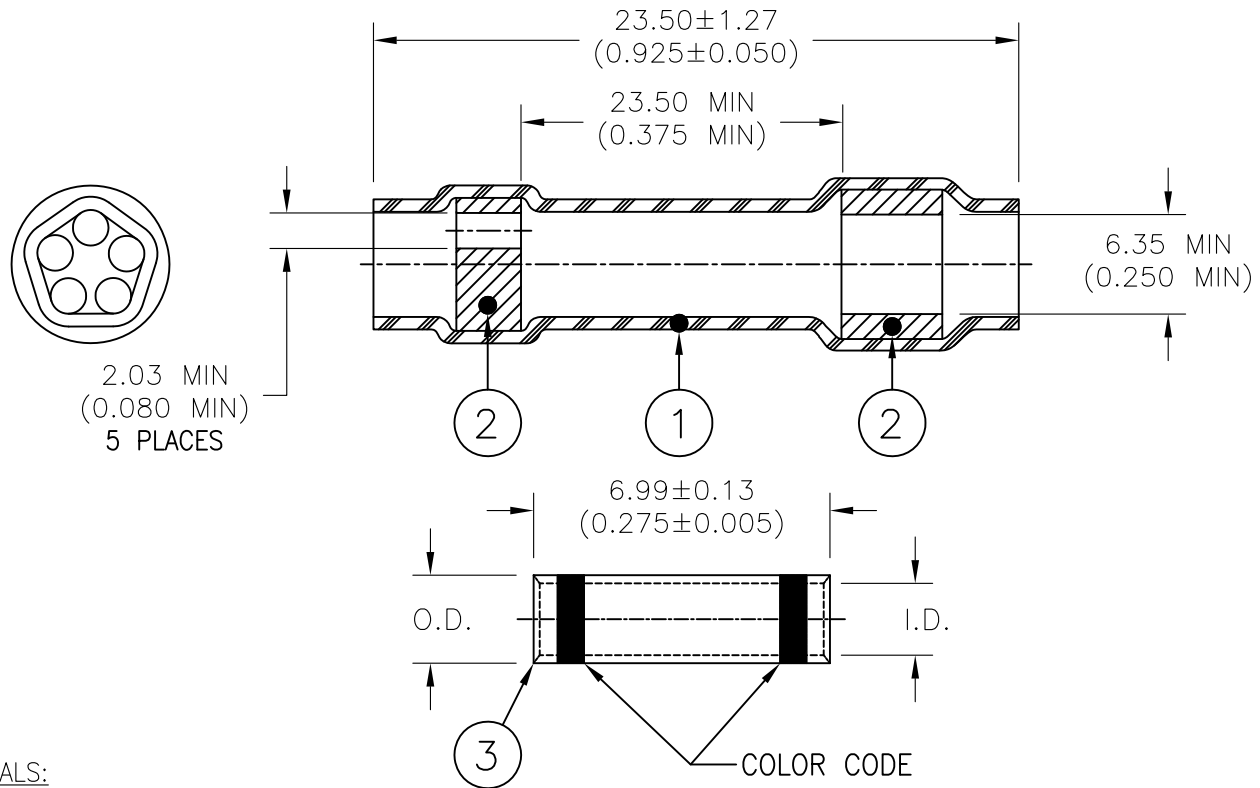

MATERIALS:

1. INSULATION SLEEVE: HEAT-SHRINKABLE, TRANSPARENT BLUE, RADIATION CROSS-LINKED, MODIFIED POLYVINYLIDENE FLOURIDE.
2. MELTABLE SEALING RINGS: MODIFIED THERMOPLASTIC.
3. SEAMLESS STUB SPLICER: BASE METAL: COPPER ALLOY 101 OR 102 PER ASTM B-75.
PLATING: NICKEL PER QQ-N-290. / COLOR CODE: SEE TABLE BELOW.

PART NAME	PROD. REV.	CMA Range*	I.D.	O.D.	MAX WEIGHT	COLOR CODE
D-436-77	D	779-2680	1.75 (0.069) 1.65 (0.065)	2.67 (0.105) 2.57 (0.101)	1.65 Lbs/Mpc	BLUE
D-436-78	D	1900-6775	2.60 (0.102) 2.49 (0.098)	3.89 (0.153) 3.73 (0.147)	2.15 Lbs/Mpc	YELLOW

* NOT ALL WIRE COMBINATIONS FALLING WITH IN THE CMA RANGE CAN BE ACCOMMODATED WITHIN THE SPLICER BARREL. FOR A LIST OF SOME OF THE USABLE WIRE COMBINATIONS WHICH CAN BE SPLICED AND SEALED, SEE THE THERMOFIT SPLICING TABLE D-436-60/-61.

© 2017 TE CONNECTIVITY Corporation. All Rights Reserved.

CUSTOMER DRAWING

			TE Connectivity			TITLE: STUB SPLICE SEALING SYSTEM, MULTI-WIRE	
Unless otherwise specified, dimensions are in millimeters. [Inches dimensions are shown in brackets]			Raychem Devices			DOCUMENT NUMBER: D-436-77/-78	
TOLERANCES: 0.00 N/A 0.0 N/A 0 N/A	ANGLES: N/A ROUGHNESS IN MICRON	Tyco Electronics reserves the right to amend this drawing at any time. Users should evaluate the suitability of the product for their application.			REV: A2		DATE: June 16, 2017
DRAWN BY: M. FORONDA	DRAWN DATE: 12/5/2000	CAGE CODE: 09090	ECO NUMBER: ECO-17-008496	SCALE: NTS		SIZE: A	SHEET: 1 of 2

1. APPLICATION

1. These parts are designed to provide an immersion resistant stub splice made with wires having insulations rated for at least 135°C.
2. Part will seal assemblies which require insertion of not more than two wires per hole of the inserts. If two wires are inserted through one hole, they must be of the same gauge size.
3. Recovered dimensions of the insulation sleeve: I.D: 3.18 (0.125) Max. / Wall: 0.33 (0.013) Min.

INSTALLATION PROCEDURE:

1. Pass wires to be crimped through the holes of the multi-holed insert (NOT MORE THE TWO WIRES THROUGH ANY HOLE). Care must be taken to avoid twisting of the wires as this will prevent proper positioning of the sleeve.
2. Strip wires 7.94 to 8.73 (5/16" to 11/32")
3. Insert wires into crimp splicer leaving a gap of 0.79 (1/32") between the wire insulation and the barrel.
4. Crimp using a Raychem AD-1377 Crimp Tool or equivalent.
5. Slide sleeve as close as possible to the crimp barrel. Hold sleeve in this position by squeezing the wires directly behind it.
6. Apply heat as follows using TE Connectivity recommended heating tools listed in Table 1 below:
 - a. Center assembly in the reflector well long enough to cause the center section of the sleeve to recover and lock itself in place.
 - b. Move assembly to position the top (major wire entry end) in the hot air stream. Hold in this position until insert has completely melted and flowed axially along the wires.
 - c. Apply heat to bottom of the sleeve until insert melts and flows.
 - d. The total time required to install the sealing sleeve is dependant upon the air-stream temperature and mass of the crimped assembly being encapsulated.

7. TE Connectivity RECOMMENDED HEATING TOOLS:

HEATER	REFLECTOR	RECOMMENDED TEMPERATURE
STEINEL HL-2010E	832011-000	316°C-371°C (600°F-700°F)
THERMOGUN #500A	TG-14	316°C-371°C (600°F-700°F)
TABLE 1		

©2017 TE CONNECTIVITY Corporation. All Rights Reserved.

CUSTOMER DRAWING

		TE Connectivity		TITLE: STUB SPLICE SEALING SYSTEM, MULTI-WIRE	
Unless otherwise specified, dimensions are in millimeters. [Inches dimensions are shown in brackets]			Raychem Devices		DOCUMENT NUMBER: D-436-77/-78
TOLERANCES: 0.00 N/A 0.0 N/A 0 N/A	ANGLES: N/A ROUGHNESS IN MICRON	Tyco Electronics reserves the right to amend this drawing at any time. Users should evaluate the suitability of the product for their application.		REV: A2	DATE: June 16, 2017
DRAWN BY: M. FORONDA	DRAWN DATE: 12/5/2000	CAGE CODE: 09090	ECO NUMBER: ECO-17-008496	SCALE: NTS	SIZE: A SHEET: 2 of 2

Mouser Electronics

Authorized Distributor

Click to View Pricing, Inventory, Delivery & Lifecycle Information:

[TE Connectivity:](#)

[D-436-77](#)