



D38999/22 Dummy Storage Receptacle Threaded Coupling

MATING CONNECTOR

MIL-DTL-38999 Series III

Shell Size Code

(For shell size codes A, A1 and A2, see notes)

D38999/22

B

W

Basic
Part No.

Class per Spec

G = Aluminum, Electroless Nickel
J = Composite, Cadmium Plated, Olive Drab
K = Corrosion-Resistant Steel Passivate
M = Composite, Electroless Nickel Plated
W = Aluminum, Cadmium Plated, Olive Drab

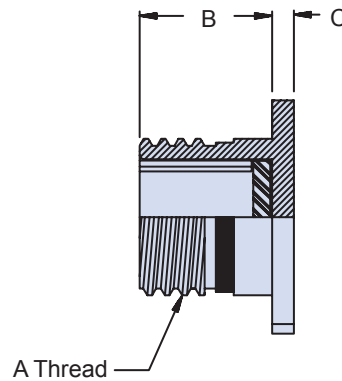
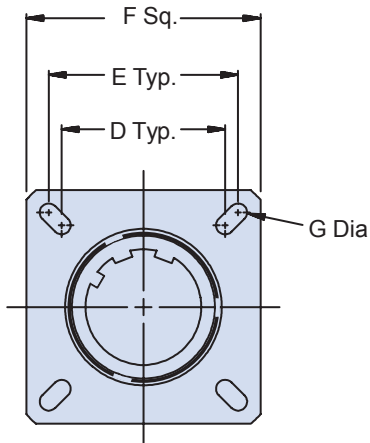

TABLE I: Shell Size Code and Dimensions

Shell Size Code	Shell Size Ref.	A Thread	B -0.0		C		D	
				Max	+0.012	(0.3)		
A (See Note 6)	9	.625-.1P-3LTS	.820	(20.83)	.098	(2.5)	.594	(15.09)
A1 (See Note 4)	9	.625-.1P-3LTS	.820	(20.83)	.098	(2.5)	.594	(15.09)
A2 (See Note 5)	9	.625-.1P-3LTS	.820	(20.83)	.098	(2.5)	.594	(15.09)
B	11	.750-.1P-3LTS	.820	(20.83)	.098	(2.5)	.719	(18.26)
C	13	.875-.1P-3LTS	.820	(20.83)	.098	(2.5)	.812	(20.62)
D	15	1.000-.1P-3LTS	.820	(20.83)	.098	(2.5)	.906	(23.01)
E	17	1.187-.1P-3LTS	.820	(20.83)	.098	(2.5)	.969	(24.61)
F	19	1.250-.1P-3LTS	.820	(20.83)	.098	(2.5)	1.062	(26.97)
G	21	1.375-.1P-3LTS	.790	(20.07)	.126	(3.2)	1.156	(29.36)
H	23	1.500-.1P-3LTS	.790	(20.07)	.126	(3.2)	1.250	(31.75)
J	25	1.625-.1P-3LTS	.790	(20.07)	.126	(3.2)	1.375	(34.93)

TABLE I: Shell Size Code and Dimensions

Shell Size Code	Shell Size Ref.	E	F -0.0		Ø G	
			+0.012	(0.3)	+0.008	(0.2)
A	9	.719 (18.26)	.937 (23.8)	.128 (3.25)		
B	11	.812 (20.62)	1.031 (26.2)	.128 (3.25)		
C	13	.906 (23.01)	1.126 (28.6)	.128 (3.25)		
D	15	.969 (24.61)	1.220 (31.0)	.128 (3.25)		
E	17	1.062 (26.97)	1.311 (33.3)	.128 (3.25)		
F	19	1.156 (29.36)	1.437 (36.5)	.128 (3.25)		
G	21	1.250 (31.75)	1.563 (39.7)	.128 (3.25)		
H	23	1.375 (34.93)	1.689 (42.9)	.154 (3.91)		
J	25	1.500 (38.10)	1.811 (46.0)	.154 (3.91)		

APPLICATION NOTES

1. Assembly to be identified with manufacturer's name and part number, space permitting.
2. For complete dimensions, see the applicable Military Specification.
3. Metric dimensions (mm) are in parentheses.
4. Shell size code "A1" is for polarization C, E and N only.
5. Shell size code "A2" is for polarization A, B and D only.
6. Shell size code "A" is universal polarization

Dimensions in inches (millimeters) and are subject to change without notice.

Mouser Electronics

Authorized Distributor

Click to View Pricing, Inventory, Delivery & Lifecycle Information:

Glenair:

[D38999/22AW](#) [D38999/22BW](#) [D38999/22CW](#) [D38999/22DW](#) [D38999/22EW](#) [D38999/22GW](#) [D38999/22HW](#)
[D38999/22JW](#) [M38999/9-15B](#) [M38999/10-8B](#) [D38999/22FW](#) [M38999/10-18B](#) [M38999/9-21B](#) [M38999/10-10B](#)
[M38999/10-14B](#) [D38999/22CM](#) [D38999/22BM](#) [D38999/22DM](#)