

XM7

USB Connectors

Small Interface Connectors That Conform to USB Standards

- Compliant with the USB 2.0 standard.
- Insertion durability of 1,500 times.
- USB A-type sockets for mounting on personal computers and USB hubs. USB B-type sockets for mounting on printers, scanners, mice, and other peripheral devices for computers.
- See the "Standards certification / conformity list" for information on conformity to certification standards.

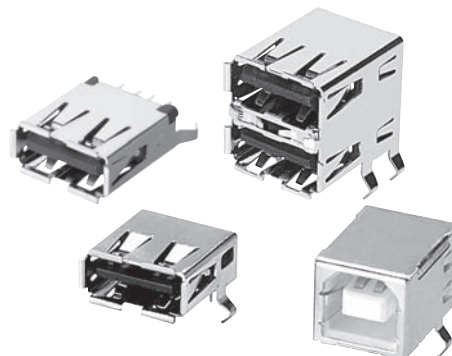

RoHS Compliant

Model Number Legend

XM7 \square -04 4 \square - \square
1 2 3 4 5

1 Type

- A: A-type socket
- B: B-type socket

2 No. of Contacts

- 04: 4 contacts

3 Plating Specification

- 4: Gold plating

4 Terminal Shape



- 1: Straight DIP terminals
- 2: Right-angle DIP terminals

5 Special Specification (A-type Sockets Only)

- Blank: Single socket
- A: Double stacked sockets

Ordering Information

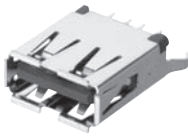
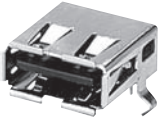
●Sockets

Item	Type	Single A-type Socket	Single A-type Socket	Double Stacked A-type Sockets	Single B-type Socket
Appearance		Straight DIP Terminals 	Right-angle DIP Terminals 	Right-angle DIP Terminals 	Right-angle DIP Terminals 
Model		XM7A-0441	XM7A-0442	XM7A-0442-A	XM7B-0442
Minimum ordering quantity (pieces)		120	150	120	150

XM7

■ Ratings and Characteristics

Rated current	1 A
Rated voltage	30 VAC
Contact resistance	30 mΩ max. (at 20 mV, 100 mA max.)
Insulation resistance	1,000 MΩ min. (at 500 VDC)
Dielectric strength	750 VAC for 1 min (leakage current: 0.5 mA max.)
Insertion durability	1,500 times
Ambient operating temperature	-40 to 60°C (with no icing or condensation)

■ Materials and Finish

Housing	PBT A-type Sockets: Black B-type Sockets: White	
Contacts	Mating end	Copper alloy/gold plating
	Terminals	Copper alloy/tin alloy plating
Shell	Copper alloy/tin plating	

■ Dimensions

(Unit: mm)

XM7A-0441 Single A-type Socket

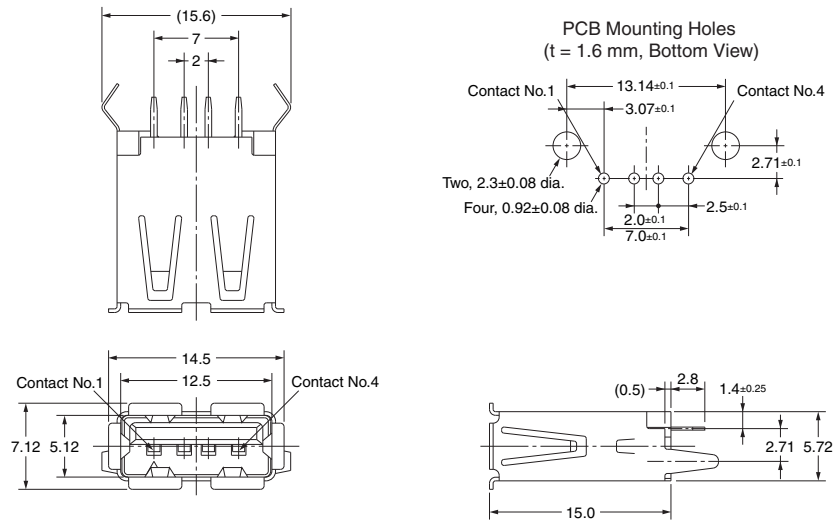

XM7A-0442 Single A-type Socket

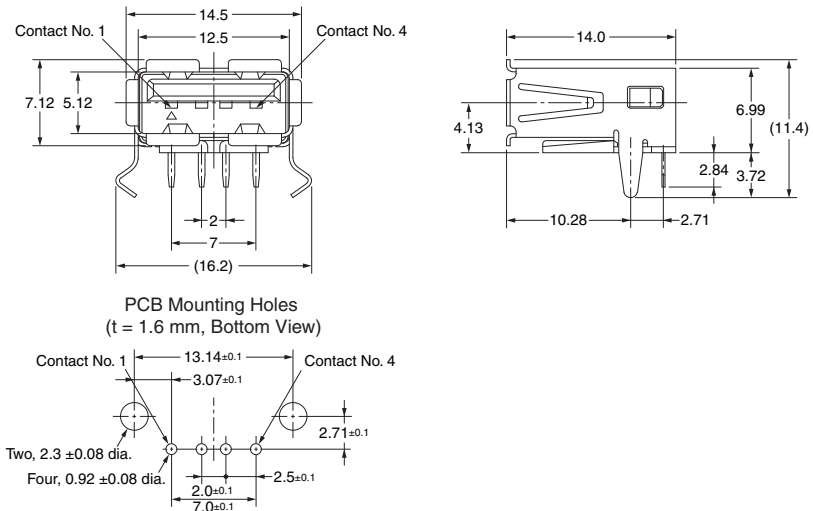
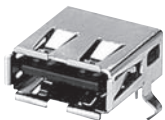

■Precautions

Precautions for Correct Use

●Automatic Soldering

Reference Information: Automated Soldering Conditions (Jet Flow)

- (1) Soldering temperature: $250 \pm 5^{\circ}\text{C}$
- (2) Continuous soldering time: 5 ± 1 s max.

●Terminal Shapes

The terminals will deform if they are subjected to an excessive load, which will in turn reduce solderability when mounting. Do not drop the Connectors or handle them carelessly. Do not connect anything when the Connectors are not mounted to a board. Doing so may deform the terminals.

●Application Precautions

- Do not connect the connectors in the wrong direction.
Doing so will damage the connectors.
- Confirm that there is no excessive misalignment or inclination in the mating contact portion between the plug and socket before mating the Connector. Make sure that the Connector is mated all the way to the back. If the Connector is not mated all the way to the back, contact reliability may be lost.
- Do not apply an extreme load during Connector insertion or removal. The Connector may be damaged, and contact failure may result. Twist the plug and socket as little as possible when mating the Connector. Not doing so may deform the terminals or housing or crack the housing.
- Do not insert a foreign object, such as tweezers, into the Connector mating contact portion. Doing so may cause the plating to peel off or deform the terminals.

●Precautions for Board Mounting

Be careful of the amount of board warping. If the board is excessively warped, soldering faults may occur.

●Storage

Do not store the Connectors in locations subject to dust or high humidity. Do not store the Connectors in locations close to sources of gasses such ammonia gas or sulfide gas.

Please check each region's Terms & Conditions by region website.

OMRON Corporation

Electronic and Mechanical Components Company

Regional Contact

Americas

<https://www.components.omron.com/>

Asia-Pacific

<https://ecb.omron.com.sg/>

Korea

<https://www.omron-ecb.co.kr/>

Europe

<http://components.omron.eu/>

China

<https://www.ecb.omron.com.cn/>

Japan

<https://www.omron.co.jp/ecb/>