

Product Overview

NCP1532: Buck Converter, DC-DC, Dual, Low Iq, High Efficiency, 2.25 MHz, 1.6 A



For complete documentation, see the data sheet.

The NCP1532 dual step down DCDC converter is a monolithic integrated circuit dedicated to supply core and I/O voltages of new multimedia design in portable applications powered from 1-cell Li-ion or 3 cell Alkaline/NiCd/NiMH batteries. Both channels are externally adjustable from 0.9V to 3.3V and can source totally up to 1.6A, 1.0A maximum per channel. Converters are running at 2.25MHz switching frequency which reduces component size by allowing the use of small inductor (down to 1uH) and capacitors and operates 180 degrees out of phase to reduce large amount of current demand on the battery. Automatic switching PWM/PFM mode and synchronous rectification offer improved system efficiency. The device can also operate into fixed frequency PWM mode for low noise applications where low ripple and good load transients are required. Additional features include integrated soft-start, cycle-by-cycle current limit and thermal shutdown protection. The device can also be synchronized to an external clock signal in the range of 2.25 MHz. The NCP1532 is available in a space saving, ultra low profile 3x3 x 0.55 mm 10 pin uDFN package.

Features

- 97% efficiency, 50uA quiescent current, 0.3 uA shutdown current
- 2.25MHz switching frequency
- Mode pin operation : Auto-switching PWM/PFM mode at light loading or PWM mode only
- Adjustable outputs voltage from 0.9V to 3.3V
- POR on reset output pin
- Can source up to 1.6A, 1.0A max per channel (800mA/800mA or 1.0A/600mA)

Benefits

- Extends battery life and 'play-time'
- Allows use of smaller inductor and capacitor
- Allow user select between low power consumption at light loading or noise and ripple performance

Applications

- Power supply for application processor
- Power supply for processor with low core voltage

End Products

- Cellular phones, smart phones, and PDAs
- MP3 players and portable audio systems

Part Electrical Specifications

Product	Compliance	Status	Topology	Control Mode	V _{CC} Min (V)	V _{CC} Max (V)	V _o Typ (V)	I _o Typ (A)	Efficiency (%)	f _{sw} Typ (kHz)	Package Type
NCP1532MUAATXG	Pb-free Halide free	Active	Step-Down	Current Mode	2.7	5.5	0.9 to 3.3	1.6	97	2250	UDFN-10

Application Diagram

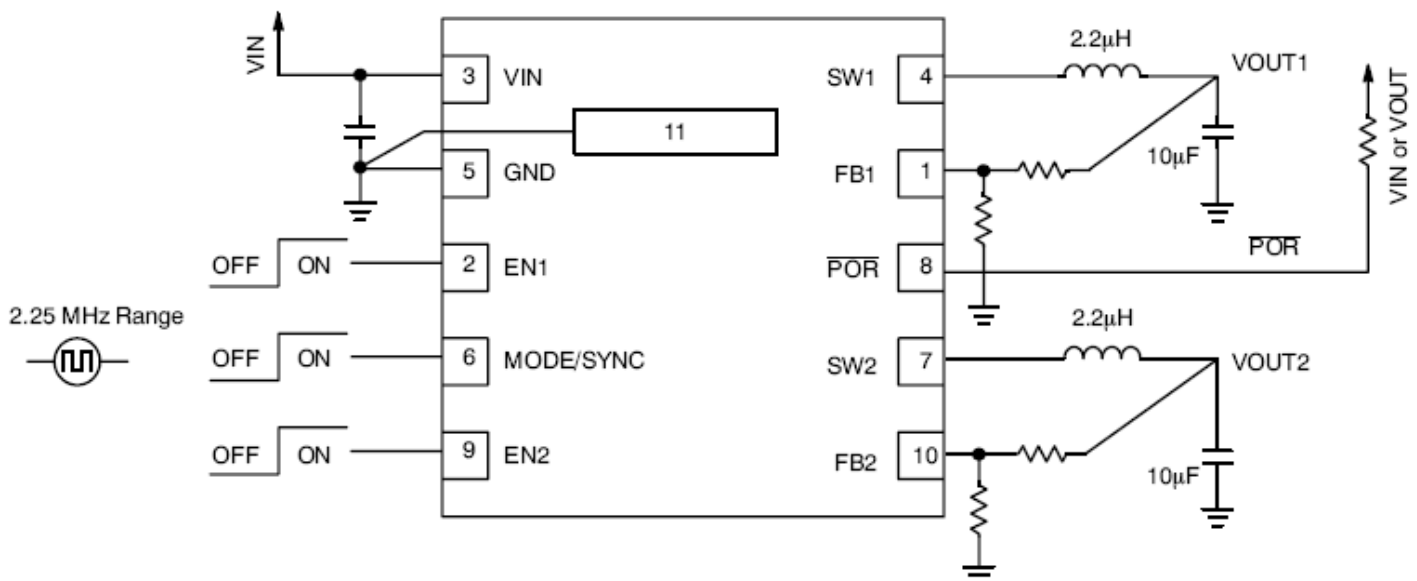

For more information please contact your local sales support at www.onsemi.com.

Created on: 11/6/2017