

PTSLR1206

Low resistance SMD PTC fuses



Product features

- Positive temperature coefficient (PTC)
- Surface mount resettable fuse
- Low resistance
- Compact 1206 (3216 metric) footprint
- Voltage rating 6 V
- Current rating from 0.75 A to 5.00 A
- Fast time-to-trip

Applications

- Data ports
- Micromotors and fans
- Low voltage test and measurement
- Low voltage hand held equipment
- PC-based medical equipment
- USB protection
- Secondary Li-ion battery protection
- Game consoles, set top boxes
- Battery charging & charging connections

Agency information

- cURus Recognized file no. E343021
- TUV: File R 50455924

Part number system/ordering:

PTSLR1206V075

- PT= PTC resettable fuse
- S= Surface mount
- LR = Low resistance
- 1206= Dimension code
- 6V= Maximum voltage
- 075= Ihold current rating (075= 0.75 A)

Product specifications

Part number	Vmax ¹	I _{max} ²	I _{hold} ³	I _{trip} ⁴	P _d ⁵	Time-to-trip (maximum)		Resistance ⁶		Part marking	Safety approvals	
	(V _{dc})	(A)	(A)	(A)	typical (W)	(A)	(seconds)	Initial (R _i) minimum (Ω)	Post trip (R ₁) maximum (Ω)		cURus	TÜV
PTSLR12066V075	6	50	0.75	1.5	0.8	8.0	0.3	0.017	0.18	La	√	√
PTSLR12066V110	6	50	1.1	2.2	0.8	8.0	0.3	0.015	0.13	Lb	√	√
PTSLR12066V150	6	50	1.5	3.0	0.8	8.0	0.3	0.010	0.080	Lc	√	√
PTSLR12066V175	6	50	1.75	3.5	0.8	8.0	0.4	0.005	0.045	L3	√	√
PTSLR12066V200	6	50	2.0	4.0	0.8	8.0	0.5	0.005	0.040	L7	√	√
PTSLR12066V260	6	50	2.6	5.0	0.8	8.0	4.0	0.003	0.030	L8	√	√
PTSLR12066V300	6	50	3.0	6.0	0.8	8.0	4.0	0.003	0.026	L9	√	√
PTSLR12066V350	6	50	3.5	7.0	0.8	8.0	5.0	0.003	0.018	L1	√	√
PTSLR12066V380	6	50	3.8	8.0	0.8	8.0	5.0	0.002	0.014	L2	√	√
PTSLR12066V400	6	50	4.0	8.0	0.8	20	2.0	0.001	0.014	L5	√	√
PTSLR12066V450	6	50	4.5	9.0	0.8	22	2.0	0.001	0.014	L6	√	√
PTSLR12066V500	6	50	5.0	10	0.8	25	2.0	0.001	0.013	Le	√	√

- V_{max}: Maximum continuous voltage the device can withstand without damage at rated current
- I_{max}: Maximum fault current the device can withstand without damage at rated voltage
- I_{hold}: Maximum current the device will pass without interruption at +23 °C still air unless otherwise specified
- I_{trip}: Minimum current that will transition the device from low resistance to high resistance at +23 °C still air, unless otherwise specified

- P_d: Power dissipated from the device when in tripped state at +23 °C still air, unless otherwise specified
- R_i: Minimum resistance of the device prior to tripping at +23 °C
R₁: Maximum resistance of the device one hour after tripping at +23 °C

Dimensions—mm

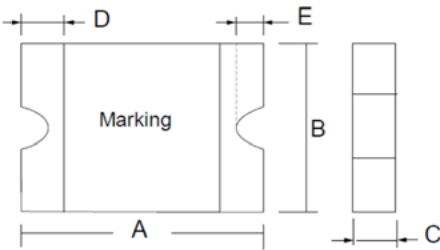

Recommended pad layout

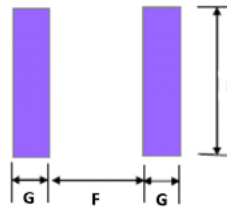

A min	A max	B min	B max	C min	C max	D min	D max	E min	E max	F	G	H
3.00	3.50	1.50	1.80	0.40*	0.70*	0.125	0.75	0.08	0.45	2.0	1.0	1.9
				0.60**	1.20**							

* PTSLR12066V075, PTSLR12066V110, PTSLR12066V150,

** PTSLR12066V175, PTSLR12066V200, PTSLR12066V260, PTSLR12066V300, PTSLR12066V350, PTSLR12066V380, PTSLR12066V400, PTSLR12066V450, PTSLR12066V500

Thermal derating curve

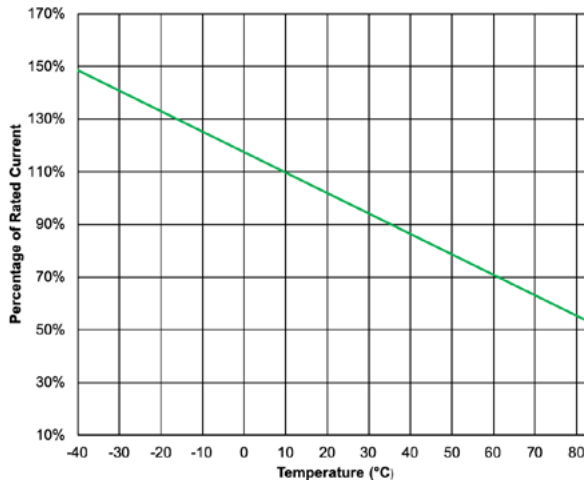

General specifications

Operating temperature: -40 °C to + 85 °C (with derating)
Storage temperature: -10 °C to + 40 °C
Storage relative humidity: ≤75%
Storage condition: Keep away from corrosive atmosphere and sunlight
Passive aging: IEC60738-1, +85 ± 5 °C, 1000 ± 24 hours
Humidity aging: +85 °C, 80 to 85% relative humidity, 100 ± 5 hours
Rapid change of temperature: IEC60738-1, +85 ± 5/-40 ± 5 °C , 20 cycles, 30 minutes
Overload endurance: UL1434, Vmax, 120% Imax, 50 cycles Vmax, 300% Itrip, 6000 cycles
Trip endurance: UL1434, Vmax, Itrip 1+ Imax, 1000 ± 24 hours
Solderability: IEC60068-2-58, +245 + 5 °C, 3 ± 0.3 seconds
Moisture sensitivity test: J-STD-020, MSL=2a

Packaging information

PTSLR12066V075, PTSLR12066V110, PTSLR12066V150,
Supplied in tape and reel packaging, 5000 parts per 7.0" (178 mm) diameter reel

PTSLR12066V175, PTSLR12066V200, PTSLR12066V260, PTSLR12066V300, PTSLR12066V350, PTSLR12066V380, PTSLR12066V400,
PTSLR12066V450, PTSLR12066V500

Supplied in tape and reel packaging, 2500 parts per 7.0" (178 mm) diameter reel

Taping specification

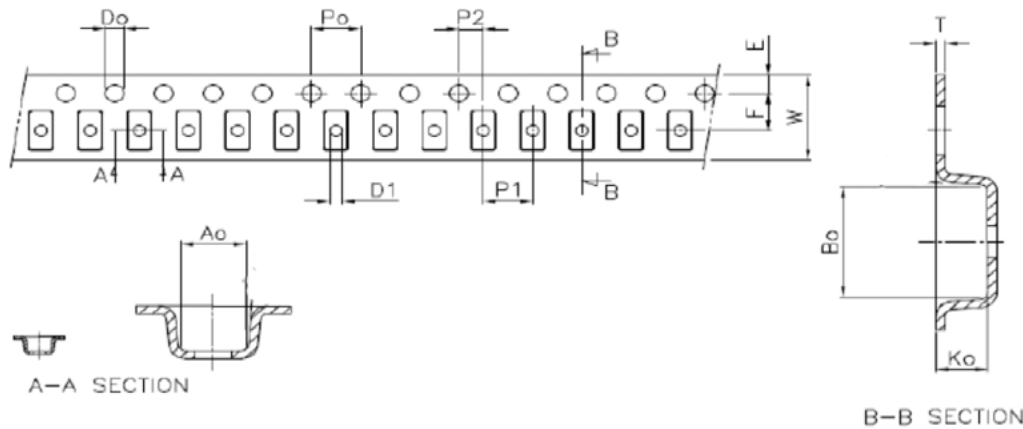

PTSLR12066V075, PTSLR12066V110, PTSLR12066V150,

A ₀	B ₀	K ₀	P ₀	P ₁	P ₂	T	E	F	D ₀	D ₁	W	10P ₀
± 0.10	± 0.10	± 0.05	± 0.10	± 0.10	± 0.10	± 0.05	± 0.10	± 0.10	± 0.05	min	± 0.30	± 0.20
1.85	3.45	0.85	4.0	4.0	2.0	0.23	1.75	3.50	1.55	1.0	8.0	40

PTSLR12066V175, PTSLR12066V200, PTSLR12066V260, PTSLR12066V300, PTSLR12066V350, PTSLR12066V380, PTSLR12066V400,
PTSLR12066V450, PTSLR12066V500

A ₀	B ₀	K ₀	P ₀	P ₁	P ₂	T	E	F	D ₀	D ₁	W	10P ₀
± 0.10	± 0.10	± 0.05	± 0.10	± 0.10	± 0.10	± 0.05	± 0.10	± 0.10	± 0.05	min	± 0.30	± 0.20
1.95	3.55	1.40	4.0	4.0	2.0	0.23	1.75	3.50	1.55	1.0	8.0	40

Wave solder profile

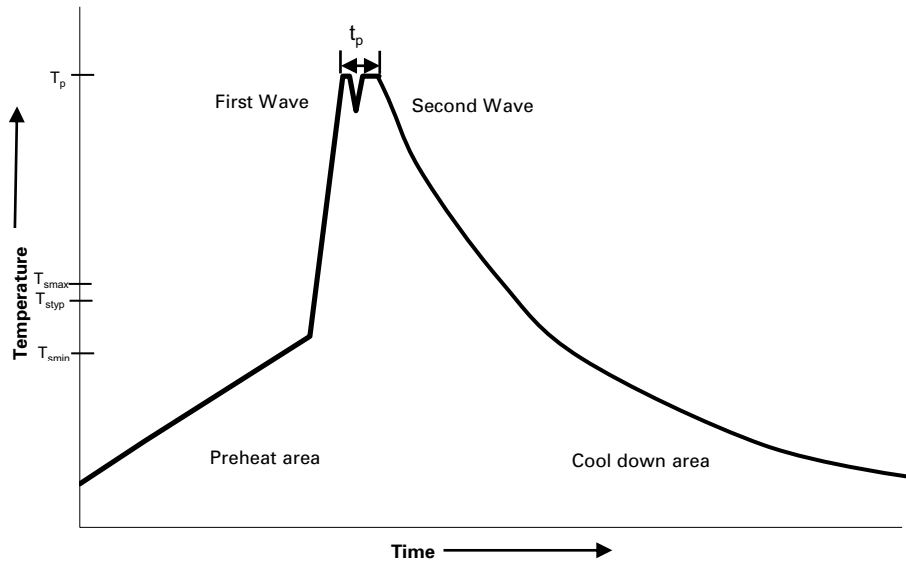

Reference EN 61760-1:2006

Profile feature	Standard SnPb solder	Lead (Pb) free solder
Preheat		
• Temperature min. (T_{smin})	100 °C	100 °C
• Temperature typ. (T_{styp})	120 °C	120 °C
• Temperature max. (T_{smax})	130 °C	130 °C
• Time (T_{smin} to T_{smax}) (t_s)	70 seconds	70 seconds
Δ preheat to max Temperature	150 °C max.	150 °C max.
Peak temperature (T_p)*	235 °C – 260 °C	250 °C – 260 °C
Time at peak temperature (t_p)	10 seconds max 5 seconds max each wave	10 seconds max 5 seconds max each wave
Ramp-down rate	~ 2 K/s min ~3.5 K/s typ ~5 K/s max	~ 2 K/s min ~3.5 K/s typ ~5 K/s max
Time 25°C to 25°C	4 minutes	4 minutes

Manual solder

+350 °C (4-5 seconds by soldering iron), generally manual/hand soldering is not recommended

Solder reflow profile

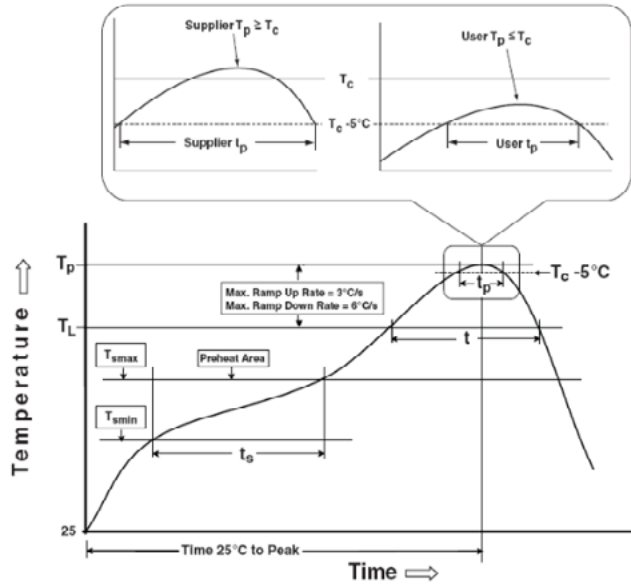

Table 1 - Standard SnPb solder (T_C)

Package thickness	Volume mm^3 <350	Volume mm^3 \geq 350
<2.5 mm)	235 °C	220 °C
\geq 2.5 mm	220 °C	220 °C

Table 2 - Lead (Pb) free solder (T_C)

Package thickness	Volume mm^3 <350	Volume mm^3 350 - 2000	Volume mm^3 >2000
<1.6 mm	260 °C	260 °C	260 °C
1.6 – 2.5 mm	260 °C	250 °C	245 °C
>2.5 mm	250 °C	245 °C	245 °C

Reference J-STD-020

Profile feature	Standard SnPb solder	Lead (Pb) free solder
Preheat and soak		
• Temperature min. (T_{smin})	100 °C	150 °C
• Temperature max. (T_{smax})	150 °C	200 °C
• Time (T_{smin} to T_{smax}) (t_s)	60-120 seconds	60-120 seconds
Ramp up rate T_L to T_P	3 °C/ second max.	3 °C/ second max.
Liquidous temperature (T_L)	183 °C	217 °C
Time (t_L) maintained above T_L	60-150 seconds	60-150 seconds
Peak package body temperature (T_P)*	235 °C	260 °C
Time (t_p)* within 5 °C of the specified classification temperature (T_C)	20 seconds*	30 seconds*
Ramp-down rate (T_P to T_L)	6 °C/ second max.	6 °C/ second max.
Time 25 °C to peak temperature	6 minutes max.	8 minutes max.

* Tolerance for peak profile temperature (T_P) is defined as a supplier minimum and a user maximum.

Life Support Policy: Eaton does not authorize the use of any of its products for use in life support devices or systems without the express written approval of an officer of the Company. Life support systems are devices which support or sustain life, and whose failure to perform, when properly used in accordance with instructions for use provided in the labeling, can be reasonably expected to result in significant injury to the user.

Eaton reserves the right, without notice, to change design or construction of any products and to discontinue or limit distribution of any products. Eaton also reserves the right to change or update, without notice, any technical information contained in this bulletin.

Eaton
Electronics Division
1000 Eaton Boulevard
Cleveland, OH 44122
United States
Eaton.com/electronics

© 2020 Eaton
All Rights Reserved
Printed in USA
Publication No. 11048 BU-MC20025
March 2020

Eaton is a registered trademark.

All other trademarks are property of their respective owners.

Follow us on social media to get the latest product and support information.



Mouser Electronics

Authorized Distributor

Click to View Pricing, Inventory, Delivery & Lifecycle Information:

Eaton:

[PTSLR12066V075](#) [PTSLR12066V110](#) [PTSLR12066V150](#) [PTSLR12066V175](#) [PTSLR12066V200](#)
[PTSLR12066V260](#) [PTSLR12066V300](#) [PTSLR12066V350](#) [PTSLR12066V380](#) [PTSLR12066V400](#) [PTSLR12066V450](#)
[PTSLR12066V500](#)