

# GBJ20005 - GBJ2010/G

Single Phase 20Amp Glass passivated Bridge Rectifiers

## Features

- Glass passivated die construction
- Low forward voltage drop
- High current capability
- High surge current capability
- Plastic material-UL flammability 94V-0
- The G suffix is uses for photoresist chip, otherwise it is a knife scraping chip

## MECHANICAL DATA

- Case: Molded plastic, GBJ
- Terminals: Plated Leads Solderable perMIL-STD-202, Method 208
- Polarity: As Marked on Case
- Mounting Position: Any
- Marking: Type Number
- Lead Free: For RoHS / Lead Free Version

## Mechanical Data

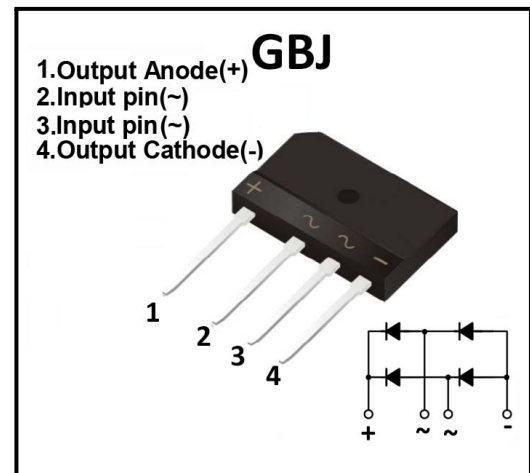

## Maximum Ratings And Electrical Characteristics (@T<sub>A</sub>=25°C unless otherwise noted)

Symbol	Parameter	GBJ 20005	GBJ 2001	GBJ 2002	GBJ 2004	GBJ 2006	GBJ 2008	GBJ 2010	Unit
V <sub>RRM</sub>	repetitive peak reverse voltage	50	100	200	400	600	800	1000	V
V <sub>RWM</sub>	Working Peak Reverse Voltage	50	100	200	400	600	800	1000	
V <sub>RMS</sub>	RMS voltage	35	70	140	280	420	560	700	
V <sub>DC</sub>	DC blocking voltage	50	100	200	400	600	800	1000	
I <sub>FAV</sub>	Average Rectified Output Current (Note 1)@T <sub>C</sub> =90°C	20.0							A
I <sub>FSM</sub>	Peak forward surge current, 8.3ms single half sine-wave	240							A
I <sub>t</sub> <sup>2</sup>	I <sub>t</sub> <sup>2</sup> Rating for fusing (t<8.3ms)	239.04							A <sub>S</sub> <sup>2</sup>
V <sub>FM</sub>	Forward Voltage @IF=10A per element @IF=20A	1.0 1.10							V
I <sub>R</sub>	Peak Reverse Current@T <sub>A</sub> =25°C at rated DC blocking voltage @T <sub>A</sub> =125°C	5.0 500							uA
C <sub>J</sub>	Typical junction capacitance	65							pF
R <sub>θJA</sub>	Between junction and ambient, Without heatsink	22							°C/W
R <sub>θJC</sub>	Between junction and case, With heatsink	1.1							
T <sub>J</sub>	Operation Temperature Range	-55 to +150							°C
T <sub>STG</sub>	Storage Temperature Range	-55 to +150							

Note:(1)Thermal resistance from junction to case per element. Unit mounted on 75x75x1.6mm aluminum plate heat sink.

**BORN SEMICONDUCTOR, INC. ALL RIGHT RESERVED**

Specifications are subject to change without notice.

Please refer to <http://www.born-tw.com> for current information.

Revision: 2022-Jan-1



**Ratings And Characteristic Curves**

**Figure 1: Output Current Derating Curve**

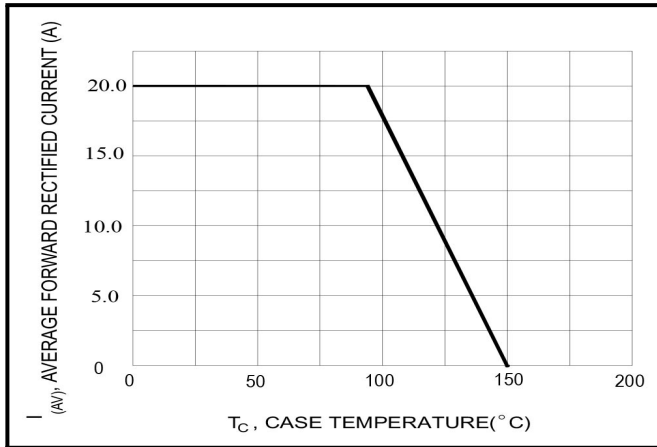

**Figure 2: Typical Forward Characteristics (per leg)**

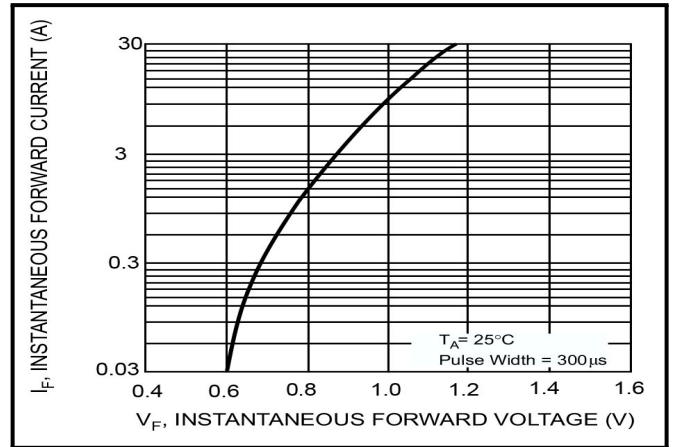

**Figure 3: Maximum Peak Forward Surge Current (per leg)**

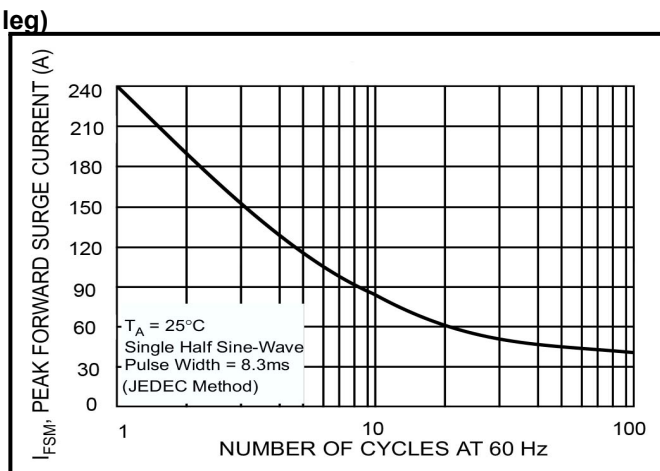

**Figure 4: Typical Junction Capacitance**

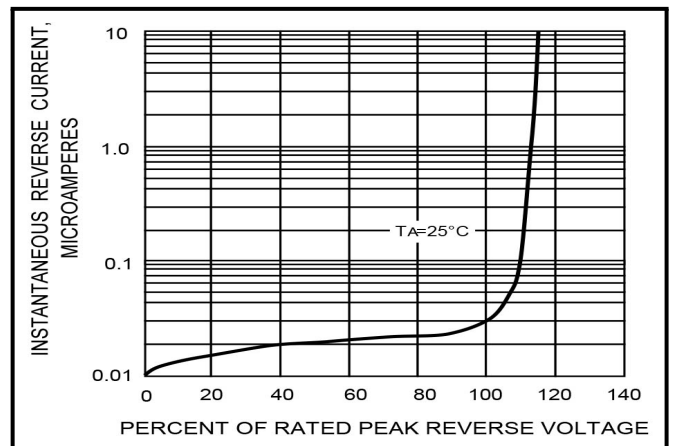

**Figure 5: TYPICAL REVERSE CHARACTERISTICS**

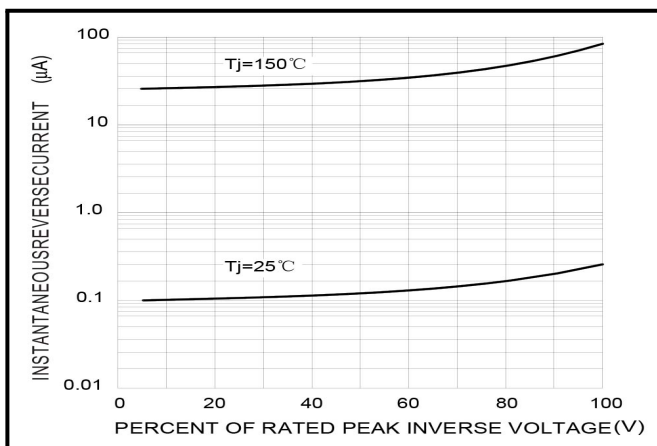

Outline Drawing -GBJ

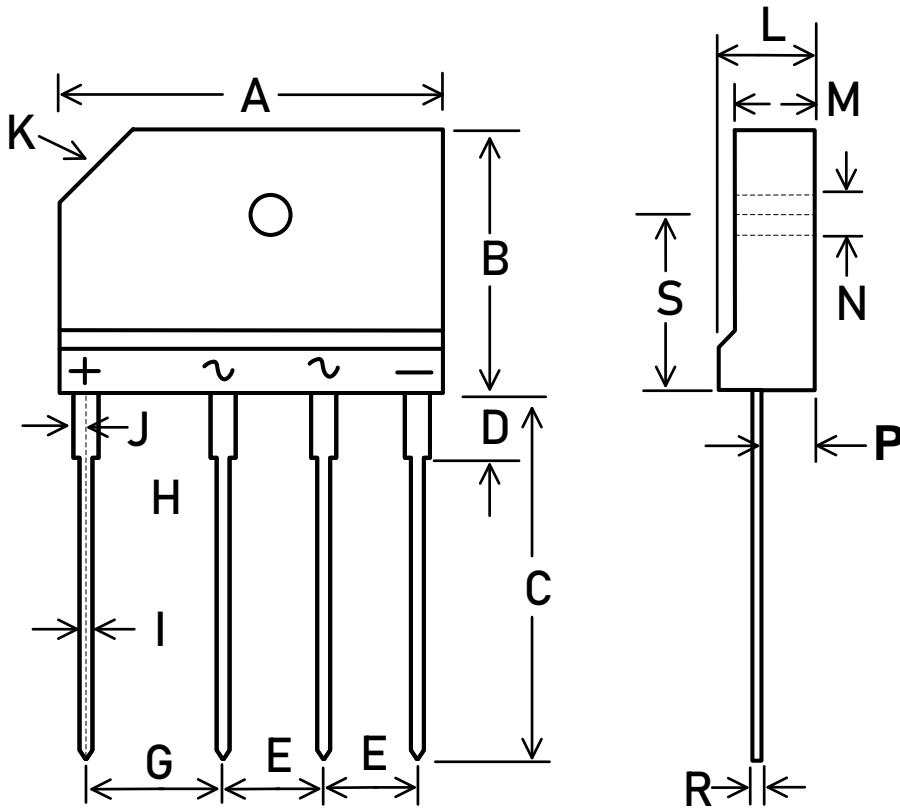

SYMBOL	MILLIMETER	
	MIN.	MAX.
A	29.70	30.3
B	19.70	20.3
C	17.00	18.00
D	3.80	4.20
E	7.30	7.70
G	9.80	10.20
H	2.00	2.40
I	0.90	1.10
J	2.30	2.70
K	3.0x45°	
L	4.40	4.80
M	3.40	3.80
N	3.10	3.40
P	2.50	2.90
R	0.60	0.80
S	10.80	11.20

