

Levelling Feet



Applications

- Gensets
- Engines
- Tooling Machinery
- Pumps
- HVAC
- Special Equipment
- General Machinery

The "ZAL" product is quite unique within the Levelling Feet market, as it can accommodate significant loads - and is therefore useful for large equipment installation. It can accept loads up to 1,000Kg each.

Material Breakdown: Plates - Steel DC04 (UNI EN 10130)
 Washers - Steel DD12 (UNI EN 10111)
 Nuts - Resistance Class 4 Bolts - Resistance Class 4.8
 Other Metal Components - 11SMnPb 37 (UNI EN 10087)
 Natural Rubber NR
 Finish - Zinc plated in accordance with CE standards CHROME VI free, white
 Stiffness Tolerance +/- 20%

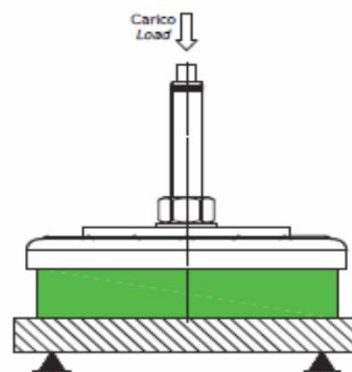
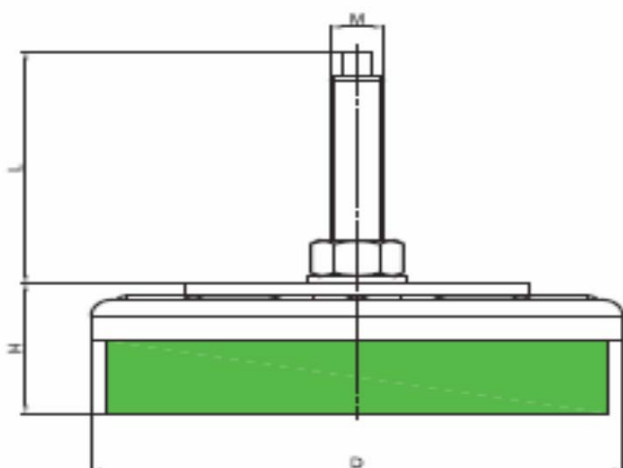

RS Ref:	Fibet Ref:	Hardness (IRHD)	D	H (Min.)	H (Max.)	M	L (Min.)	L (Max.)	Average Stiffness (daN/mm)	Max. Load (daN)	Max. Deflection (mm)
742-6840	ZAL12040V120	80	120	40	51	M16 x 1.5	93	104	400	1000	2.5