

# Photo-electric detectors

Osiris® universal detectors, design 18  
Plastic or metal case, cylindrical, M18 x 1 threaded  
Solid state output

## Presentation

Plastic case

With sensitivity adjustment and stability LED

CE

d.c. supply

Pre-cabled or plug-in connector  
Line of sight along case axis (1)



Page 2/34

Metal case

With sensitivity adjustment and stability LED

CE

d.c. supply

Pre-cabled or plug-in connector  
Line of sight along case axis (1)

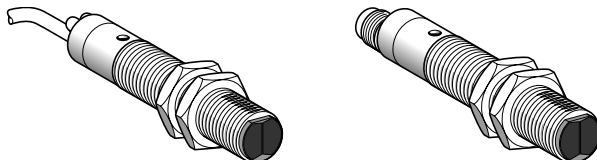

Page 2/36

a.c. or d.c. supply

Pre-cabled or plug-in connector  
Line of sight along case axis (1)

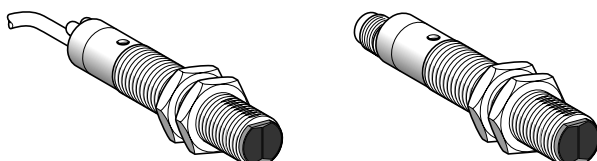

Page 2/38

(1) Line of sight 90° to case axis possible using mirror adaptor accessory.

# Photo-electric detectors

Osiris® universal detectors, design 18  
 Plastic or metal case, cylindrical, M18 x 1 threaded  
 Solid state output

Common general characteristics, schemes

## Detection characteristics

Nominal sensing distance	<b>Thru-beam system : 15 m</b> <b>Reflex system : 4 m</b> <b>Polarised reflex system : 2 m</b> <b>Diffuse system : 10 and 40 cm</b>
--------------------------	--

## Environment

Product certifications	CE, UL, CSA
Ambient air temperature	Operation : - 25...+ 55 °C. Storage : - 40...+ 70 °C
Vibration resistance	25 gn, amplitude ± 2 mm (f = 10...55 Hz), conforming to IEC 68-2-6
Shock resistance	30 gn, duration 11 ms, conforming to IEC 68-2-27
Degree of protection	<b>IP 67 conforming to IEC 529</b>

## Function table

	Function	Thru-beam and reflex systems		Diffuse system	
		No object present in the beam	Object present in the beam	No object present in the beam	Object present in the beam
Output state (PNP or NPN) indicator (illuminated when detector output is ON)	Light switching				
	Dark switching				

## Schemes

### Wiring schemes (3-wire ~)

#### Pre-cabled versions

Transmitter

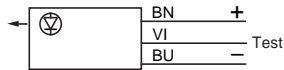

#### Light switching (no object present)

Thru-beam receiver & reflex  
PNP output

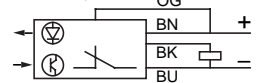

Diffuse  
PNP output

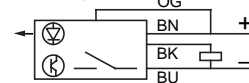

#### Dark switching (no object present)

Thru-beam receiver & reflex  
PNP output

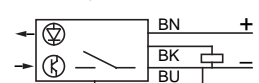

Diffuse  
PNP output

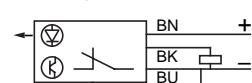

NPN output

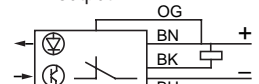

NPN output

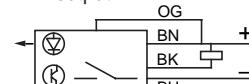

NPN output

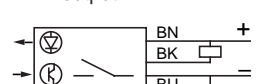

NPN output

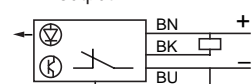

#### Plug-in connector versions

Transmitter

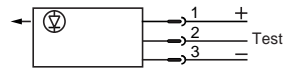

#### Light switching (no object present)

Thru-beam receiver & reflex  
PNP output

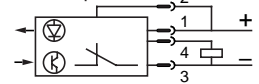

Diffuse  
PNP output

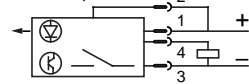

#### Dark switching (no object present)

Thru-beam receiver & reflex  
PNP output

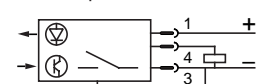

Diffuse  
PNP output

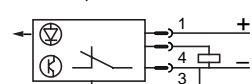

NPN output

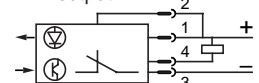

NPN output

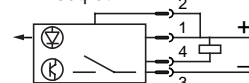

NPN output

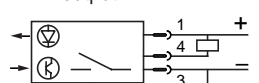

NPN output

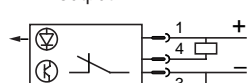

### Wiring schemes (2-wire ~)

#### Pre-cabled versions

Transmitter

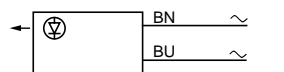

#### Light switching (no object present)

Thru-beam receiver & reflex  
Diffuse



Diffuse

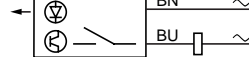

#### Dark switching (no object present)

Thru-beam receiver & reflex  
Diffuse

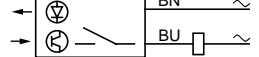

Diffuse

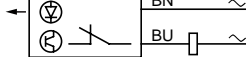

#### Plug-in connector versions

Transmitter

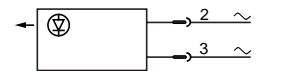

#### Light switching (no object present)

Thru-beam receiver & reflex  
Diffuse

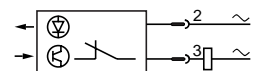

Diffuse

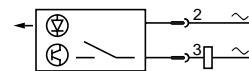

#### Dark switching (no object present)

Thru-beam receiver & reflex  
Diffuse

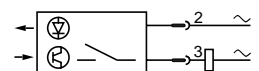

Diffuse

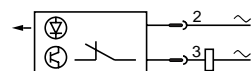

**Attention :** It is essential that a load be connected in series with the detector.

# Photo-electric detectors

Osiris® universal detectors. Plastic case, cylindrical, M18 x 1 threaded  
d.c. supply. Solid state output  
With sensitivity adjustment and stability LED

Accessories :  
pages 2/118 to 2/123

References, characteristics

Design 18

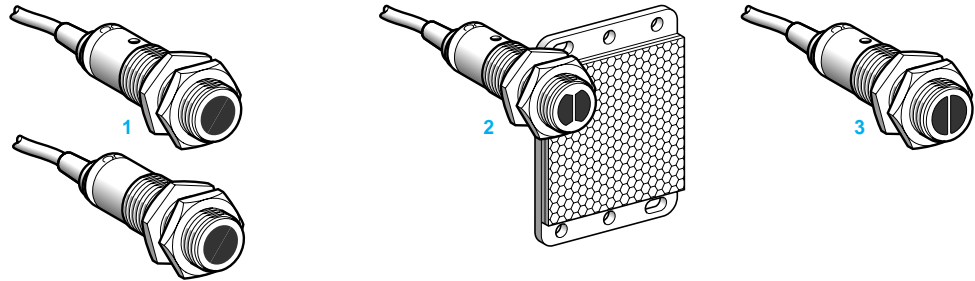

System	Thru-beam 1	Reflex 2	Polarised reflex 2	Diffuse 3	
Type of transmission	Infra-red	Infra-red	Red	Red	Infra-red
Nominal sensing distance (Sn)	15 m (transmitter + receiver)	4 m (with 50 x 50 mm reflector)	2 m (with 50 x 50 mm reflector)	0.10 m	0.40 m

References of pre-cabled versions

3-wire, PNP	Light or dark programmable switching	XU2-B18PP340 (1)	XU1-B18PP340 (2)	XU9-B18PP340 (2)	XU8-B18PP340	XU5-B18PP340
3-wire, NPN	Light or dark programmable switching	XU2-B18NP340 (1)	XU1-B18NP340 (2)	XU9-B18NP340 (2)	XU8-B18NP340	XU5-B18NP340
Weight (kg)		0.150	0.095	0.095	0.075	0.075

References of plug-in connector versions

3-wire, PNP	Light or dark programmable switching	XU2-B18PP340D (1)	XU1-B18PP340D (2)	XU9-B18PP340D (2)	XU8-B18PP340D	XU5-B18PP340D
3-wire, NPN	Light or dark programmable switching	XU2-B18NP340D (1)	XU1-B18NP340D (2)	XU9-B18NP340D (2)	XU8-B18NP340D	XU5-B18NP340D
Weight (kg)		0.040	0.040	0.040	0.020	0.020

Complementary characteristics not shown under general characteristics (page 2/33)

Connection	Pre-cabled	Diameter 4 mm cable, length 2 m, wire c.s.a. : 4 x 0.22 mm <sup>2</sup> (3 x 0.22 mm <sup>2</sup> for thru-beam transmitter)
	Connector	M12 male connector, 4-pin (suitable extension cables and female connectors types 3, 4 and 5, see page 2/124)
Materials	Case : PC/ABS ; lens : PMMA ; cable : PVC	
Rated supply voltage	= 12...24 V with protection against reverse polarity	
Voltage limits	= 10...30 V (including ripple)	
Switching capacity (sealed)	≤ 100 mA with overload and short-circuit protection	
Voltage drop, closed state	≤ 1.5 V	
Current consumption, no-load	< 35 mA (reflex and diffuse) ; ≤ 50 mA (thru-beam)	
Maximum switching frequency	500 Hz (thru-beam system : 400 Hz)	
Delays	First-up : ≤ 30 ms ; response : ≤ 1 ms ; recovery : ≤ 1 ms (thru-beam system : 1.5 ms)	

(1) Reference for both transmitter and receiver for thru-beam system detectors.

(2) 50 x 50 mm reflector included with reflex system and polarised reflex system detectors.

**Note** : These products are equivalent to the discontinued XUB short case detectors. See cross-reference tables, pages 2/126 and 2/127.

# Photo-electric detectors

Osiris® universal detectors. Plastic case, cylindrical, M18 x 1 threaded  
 d.c. supply. Solid state output  
With sensitivity adjustment and stability LED indicator

Accessories :  
 pages 2/118 to 2/123

## Curves, dimensions, schemes

### Detection curves

Thru-beam system

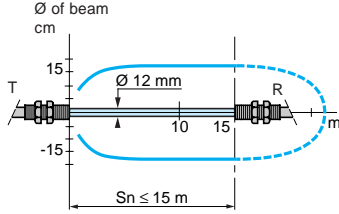

Reflex system

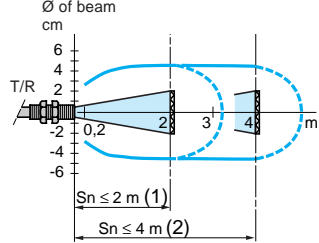

Diffuse system (Sn = 10 cm)

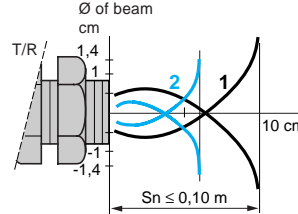

Diffuse system (Sn = 40 cm)

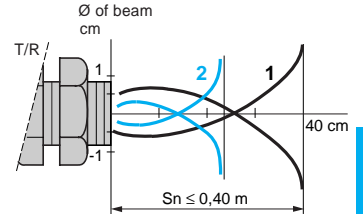

With reflector XUZ-C50  
 (1) Polarised reflex XU9-B18●P340  
 (2) Reflex XU1-B18●P340

Object 10 x 10 cm  
 1 White 90%  
 2 Grey 18%

Object 20 x 20 cm  
 1 White 90%  
 2 Grey 18%

### Excess gain curves (ambient temperature : + 25 °C)

Thru-beam system

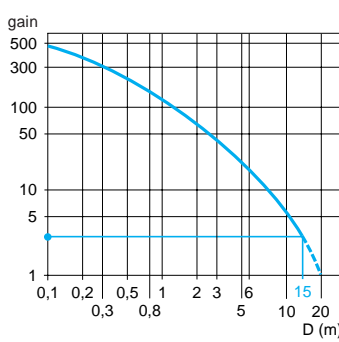

Reflex system

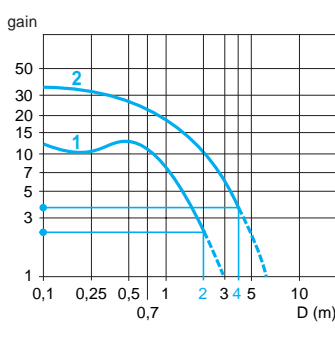

Diffuse system (Sn = 10 cm)

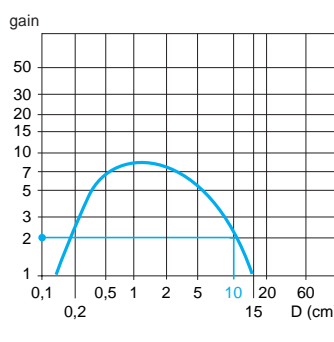

Diffuse system (Sn = 40 cm)

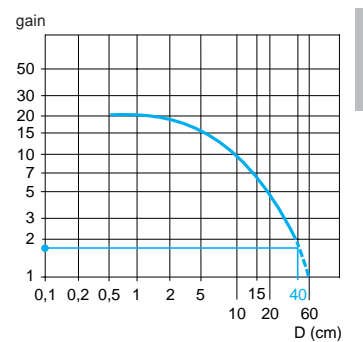

With reflector XUZ-C50  
 1 Polarised reflex XU9-B18●P340  
 2 Reflex XU1-B18●P340

Object 10 x 10 cm  
 White 90%

Object 20 x 20 cm  
 White 90%

### Dimensions

XU●-B18●P340

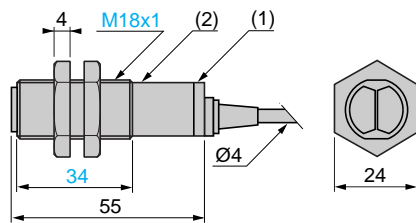

XU●-B18●P340 + XUB-Z0● (3)

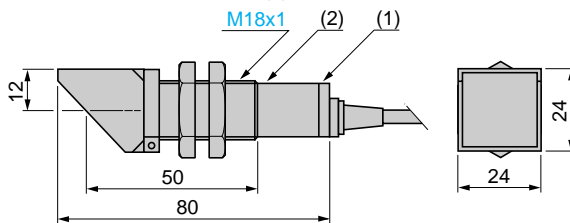

XU●-B18●P340D

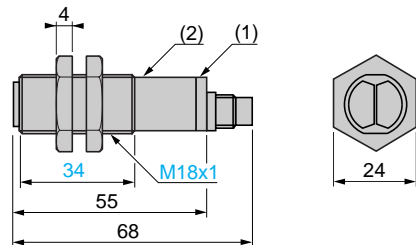

XU●-B18●P340D + XUB-Z0● (3)

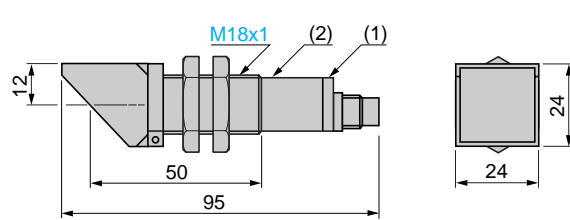

### Cable connections

(-) BU	(Blue)
(+) BN	(Brown)
(OUT) BK	(Black)
(Prog.) OG	(Orange)
(Test) VI	(Violet) for thru-beam transmitter only

### Connector schemes

Connector pin view

Transmitter Thru-beam receiver, reflex and diffuse

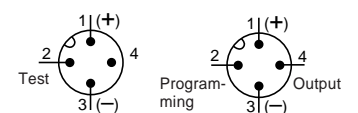

- (1) LED
- (2) Adjustment potentiometer
- (3) XUB-Z0● : mirror adaptor for reflecting beam through 90°, see page 2/118

Fixing nut tightening torque : < 4 N.m  
 Connector tightening torque : 2 N.m

**Beam break test (for thru-beam transmitter only)**  
 Beam made

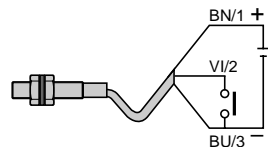

Beam broken

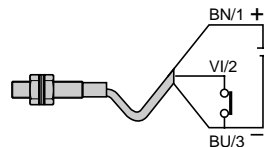

### Verification of correct operation Thru-beam and reflex systems

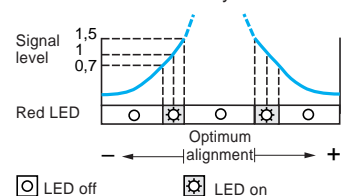

# Photo-electric detectors

Osiris® universal detectors. Metal case, cylindrical, M18 x 1 threaded  
d.c. supply. Solid state output  
With sensitivity adjustment and stability LED

Accessories :  
pages 2/118 to 2/123

References, characteristics

## Design 18

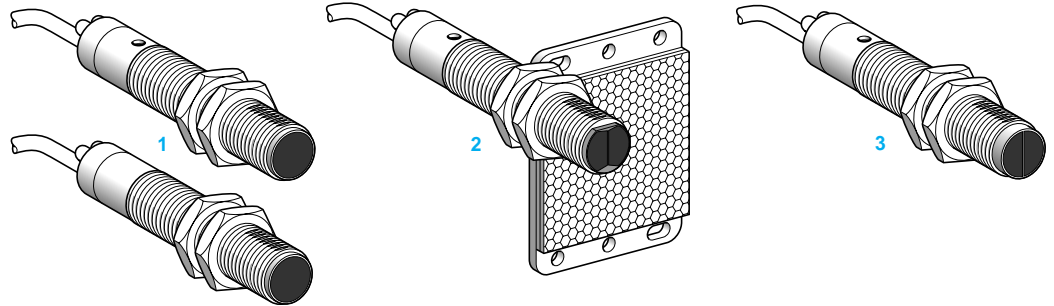

System	Thru-beam 1	Polarised reflex 2	Diffuse 3	Diffuse with adjustable background suppression 3
Type of transmission	Infra-red	Red	Infra-red	Infra-red
Nominal sensing distance (Sn)	15 m (transmitter + receiver)	2 m (with 50 x 50 mm reflector)	0.4 m	0.1 m (0.08...0.12 m)

## References of pre-cabled versions

3-wire, PNP	Light or dark programmable switching	XU2-M18PP340 (1)	XU9-M18PP340 (2)	XU5-M18PP340	XU8-M18PP340 (4)
3-wire, NPN	Light or dark programmable switching	XU2-M18NP340 (1)	XU9-M18NP340 (2)	XU5-M18NP340	XU8-M18NP340 (4)
Weight (kg)		0.285	0.170	0.150	0.150

## References of plug-in connector versions

3-wire, PNP	Light or dark programmable switching	XU2-M18PP340D (1)	XU9-M18PP340D (2)	XU5-M18PP340D	XU8-M18PP340D (4)
3-wire, NPN	Light or dark programmable switching	XU2-M18NP340D (1)	XU9-M18NP340D (2)	XU5-M18NP340D	XU8-M18NP340D (4)
Weight (kg)		0.155	0.095	0.075	0.075

## Complementary characteristics not shown under general characteristics (page 2/33)

Connection	Pre-cabled	Diameter 5 mm cable, length 2 m (3), wire c.s.a. : 4 x 0.34 mm <sup>2</sup> (3 x 0.34 mm <sup>2</sup> for thru-beam transmitter)
	Connector	M12 male connector, 4-pin (suitable extension cables and female connectors types 3, 4 and 5, see page 2/124)
Materials	Case : nickel plated brass, lens : PMMA, cable : PVC	
Rated supply voltage	= 12...24 V with protection against reverse polarity	
Voltage limits	= 10...30 V (including ripple)	
Switching capacity (sealed)	≤ 100 mA with overload and short-circuit protection	
Voltage drop, closed state	≤ 1.5 V	
Current consumption, no-load	≤ 35 mA (reflex and diffuse) ; ≤ 50 mA (thru-beam)	
Maximum switching frequency	500 Hz	
Delays	First-up : ≤ 15 ms ; response : ≤ 1 ms ; recovery : ≤ 1 ms	

- (1) Reference for both transmitter and receiver for thru-beam system detectors.  
 (2) 50 x 50 mm reflector included with polarised reflex system detectors.  
 (3) Detectors available with 5 m cable. To order, add the suffix L5 to the reference selected from above.  
 Example : detector XU9-M18PP340 with 5 m cable becomes XU9-M18PP340L5.  
 (4) These detectors do not have stability LED.

# Photo-electric detectors

Osiris® universal detectors. Metal case, cylindrical, M18 x 1 threaded  
 d.c. supply. Solid state output  
With sensitivity adjustment and stability LED

Accessories :  
 pages 2/118 to 2/123

## Curves, dimensions, schemes

### Detection curves

Thru-beam system

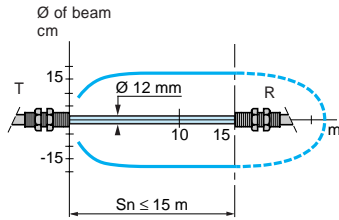

### Polarised reflex system

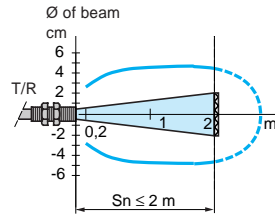

With reflector XUZ-C50

### Diffuse system (Sn = 40 cm)

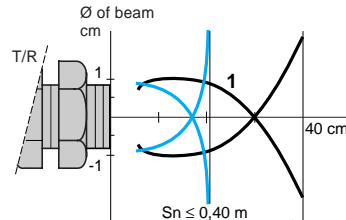

Object 10 x 10 cm  
 1 White 90%  
 2 Grey 18%

### Diffuse system with background suppression (Sn = 10 cm)

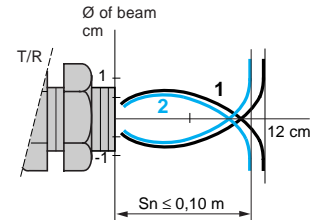

Object 10 x 10 cm  
 1 White 90%  
 2 Grey 18%

### Excess gain curves (ambient temperature : +25 °C)

#### Thru-beam system

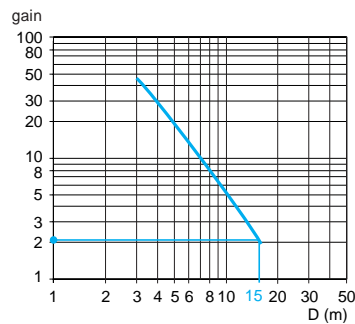

#### Polarised reflex system

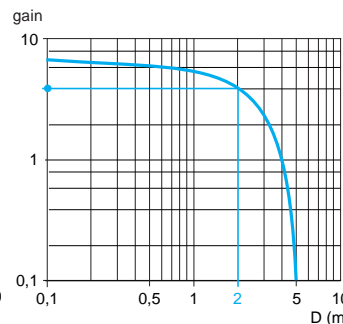

With reflector XUZ-C50

#### Diffuse system (Sn = 40 cm)

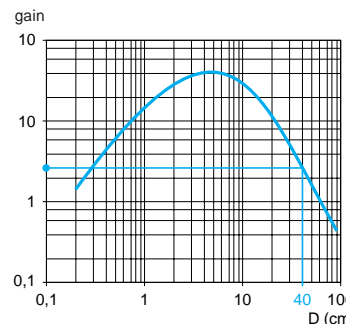

Object 10 x 10 cm  
 White 90%

### Variation of usable sensing distance S

Diffuse system with adjustable background suppression  
 Potentiometer at minimum

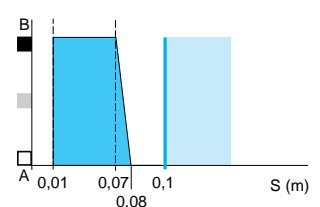

Diffuse system with adjustable background suppression  
 Potentiometer at maximum

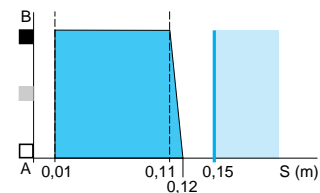

### Dimensions

#### XU-M18P340

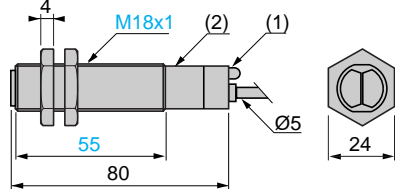

#### XU-M18P340 + XUB-Z0 (3)

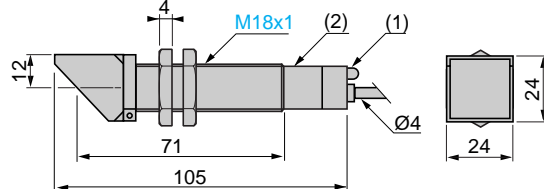

#### XU-M18P340D

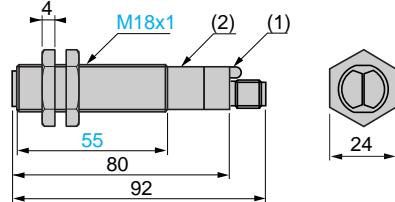

#### XU-M18P340D + XUB-Z0 (3)

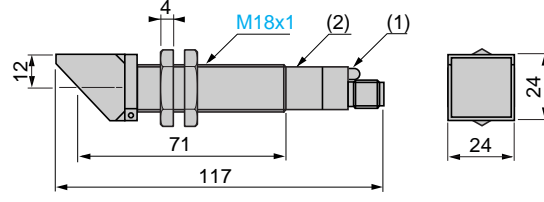

A-B : Object reflection coefficient  
 ■ Black 6 %  
 ■ Grey 18 %  
 ■ White 90 %  
 ■ Sensing range  
 ■ Non sensing zone (Matt surfaces)

(1) LED

(2) Potentiometer

Fixing nut tightening torque : 15 N.m

(3) XUB-Z0 : mirror adaptor for reflecting beam through 90°, see page 2/118

Connector tightening torque : 2 N.m

### Cable connections

- (-) BU (Blue)
- (+) BN (Brown)
- (OUT) BK (Black)
- (Prog.) OG (Orange)
- (Test) VI (Violet) only applicable to thru-beam transmitter

### Connector schemes

Connector pin view

Transmitter

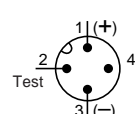

Thru-beam receiver, reflex and diffuse

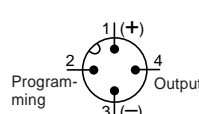

### Verification of correct operation

Thru-beam and reflex systems

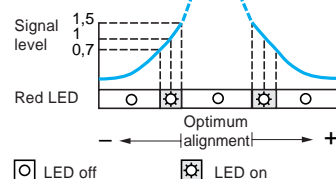

### Beam break test (for thru-beam transmitter only)

Beam made

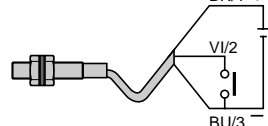

Beam broken

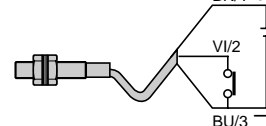

# Photo-electric detectors

Osiris® universal detectors. Metal case, cylindrical, M18 x 1 threaded  
a.c. or d.c. supply. Solid state output  
 With sensitivity adjustment

Accessories :  
 pages 2/118 to 2/123

References, characteristics

## Design 18

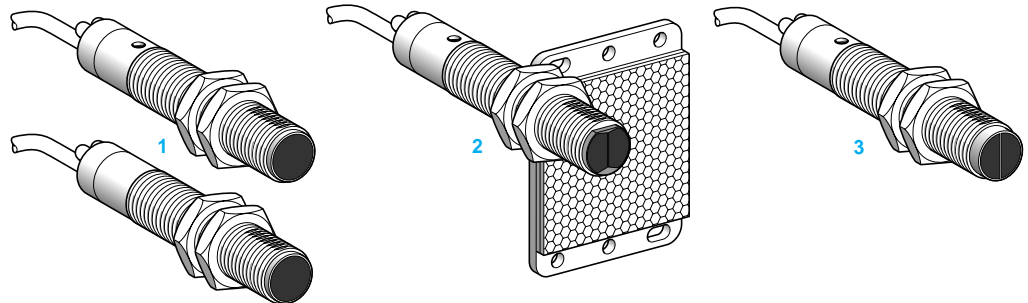

System	Thru-beam 1	Polarised reflex 2	Diffuse 3	Diffuse with adjustable background suppression 3
Type of transmission	Infra-red	Red	Infra-red	Infra-red
Nominal sensing distance (Sn)	15 m (transmitter + receiver)	2 m (with 50 x 50 mm reflector)	0.4 m	0.1 m (0.08...0.12 m)

## References of pre-cabled versions

2-wire, 24...240 V	Light switching	XU2-M18MB230 (1)	XU9-M18MB230 (2)	XU5-M18MA230	XU8-M18MA230
	Dark switching	XU2-M18MA230 (1)	XU9-M18MA230 (2)	XU5-M18MB230	XU8-M18MB230
Weight (kg)		0.285	0.170	0.150	0.150

## References of plug-in connector versions

2-wire, 24...240 V	Light switching	XU2-M18MB230K (1)	XU9-M18MB230K (2)	XU5-M18MA230K	XU8-M18MA230K
	Dark switching	XU2-M18MA230K (1)	XU9-M18MA230K (2)	XU5-M18MB230K	XU8-M18MB230K
Weight (kg)		0.155	0.095	0.075	0.075

## Complementary characteristics not shown under general characteristics (page 2/33)

Connection	Pre-cabled	Diameter 5 mm cable, length 2 m (3), wire c.s.a. : 2 x 0.5 mm <sup>2</sup>
	Connector	Ø 12 male connector, 3-pin (suitable female extension cables types 6 and 7, see pages 2/124 and 2/125)
Materials	Case : nickel plated brass, lens : PMMA, cable : PVC	
Rated supply voltage	==/~ 24...240 V	
Voltage limits	==/~ 20...264 V (including ripple on ==)	
Switching capacity (sealed)	10...200 mA (4)	
Voltage drop, closed state	< 6 V	
Residual current, open state	< 1.5 mA	
Maximum switching frequency	25 Hz	
Delays	First-up : ≤ 300 ms ; response : ≤ 20 ms ; recovery : ≤ 20 ms	

1) Reference for both transmitter and receiver for thru-beam system detectors.

(2) 50 x 50 mm reflector included with polarised reflex system detectors.

(3) Detectors available with 5 m cable. To order, add the suffix L5 to the reference selected from above.

Example : detector XU9-M18MA230 with 5 m cable becomes XU9-M18MA230L5.

(4) These detectors do not incorporate overload or short-circuit protection and therefore, it is recommended that a 0.8 A "quick-blow" fuse be connected in series with the load. See page 2/120.



# Photo-electric detectors

Osiris® universal detectors. Metal case, cylindrical, M18 x 1 threaded  
a.c. or d.c. supply. Solid state output  
 With sensitivity adjustment

Accessories :  
 pages 2/118 to 2/123

Curves, dimensions, schemes

## Detection curves

Thru-beam system

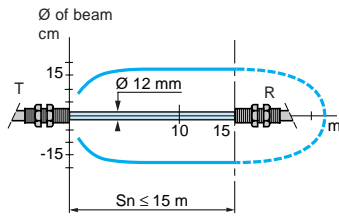

## Polarised reflex system

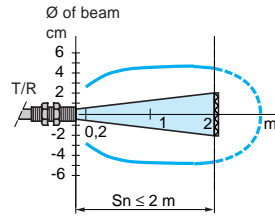

## Diffuse system (Sn = 40 cm)

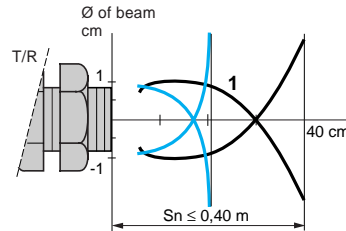

## Diffuse system with background suppression (Sn = 10 cm)

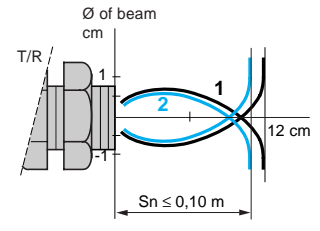

Object 10 x 10 cm  
 1 White 90%  
 2 Grey 18%

Object 10 x 10 cm  
 1 White 90%  
 2 Grey 18%

## Excess gain curves (ambient temperature : + 25 °C)

### Thru-beam system

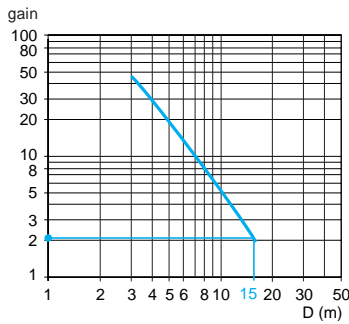

### Polarised reflex system

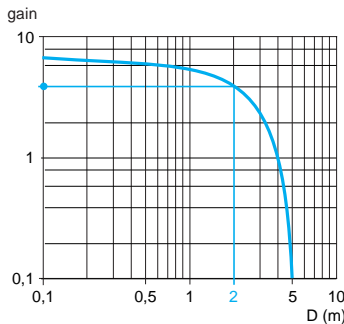

### Diffuse system (Sn = 40 cm)

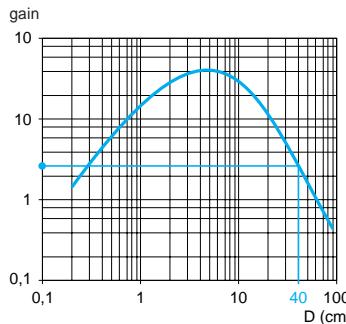

## Variation of usable sensing distance S

Diffuse system with adjustable background suppression  
 Potentiometer at minimum

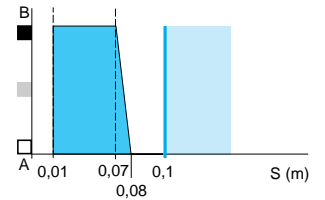

Diffuse system with adjustable background suppression  
 Potentiometer at maximum

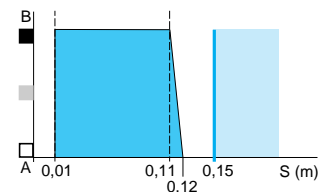

A-B : Object reflection coefficient  
 Black 6 %  
 Grey 18 %  
 White 90 %  
 Sensing range  
 Non sensing zone (Matt surfaces)

## Dimensions

### XU-M18M230

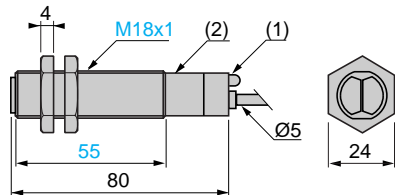

### XU-M18M230 + XUB-Z0 (3)

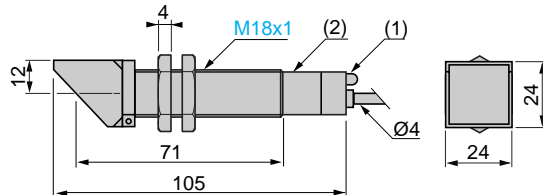

### XU-M18M230K

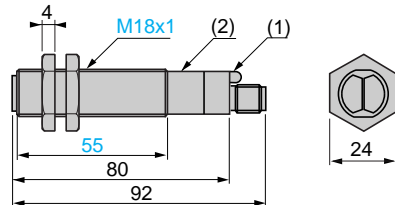

### XU-M18M230K + ZUB-Z0 (3)

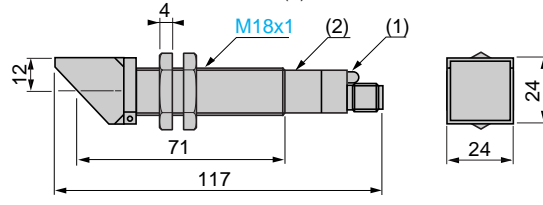

(1) LED

(2) Potentiometer

Fixing nut tightening torque : 15 N.m

## Cable connections

- (~) BU (Blue)
- (~) BN (Brown)

(3) XUB-Z0 : mirror adaptor for reflecting beam through 90°, see page 2/118

Connector tightening torque : 2 N.m

## Connector scheme

Connector pin view

Thru-beam, reflex and diffuse

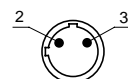

**Attention** : It is essential that a load be connected in series with the detector.