

**T SERIES**  
**IP 68 PUSH-PULL CONNECTORS**



## Precision modular connectors to suit your application

Since its creation in Switzerland in 1946 the LEMO Group has been recognized as a global leader of circular Push-Pull connectors and connector solutions. Today LEMO and its affiliated companies, REDEL and COELVER, are active in more than 80 countries with the help of over 40 subsidiaries and distributors.

## Over 75000 connectors

The modular design of the LEMO range provides over 75000 connectors from miniature  $\varnothing$  3 mm to  $\varnothing$  50 mm, capable of handling cable diameters up to 30 mm and for up to 114 contacts. This vast portfolio enables you to select the ideal connector configuration to suit almost any specific requirement in most markets, including medical devices, test and measurement instruments, machinery, audio video broadcast, telecommunications and military.

## LEMO's Push-Pull Self-Latching Connection System

This self-latching system is renowned worldwide for its easy and quick mating and unmating features. It provides absolute security against vibration, shock or pull on the cable, and facilitates operation in a very limited space.

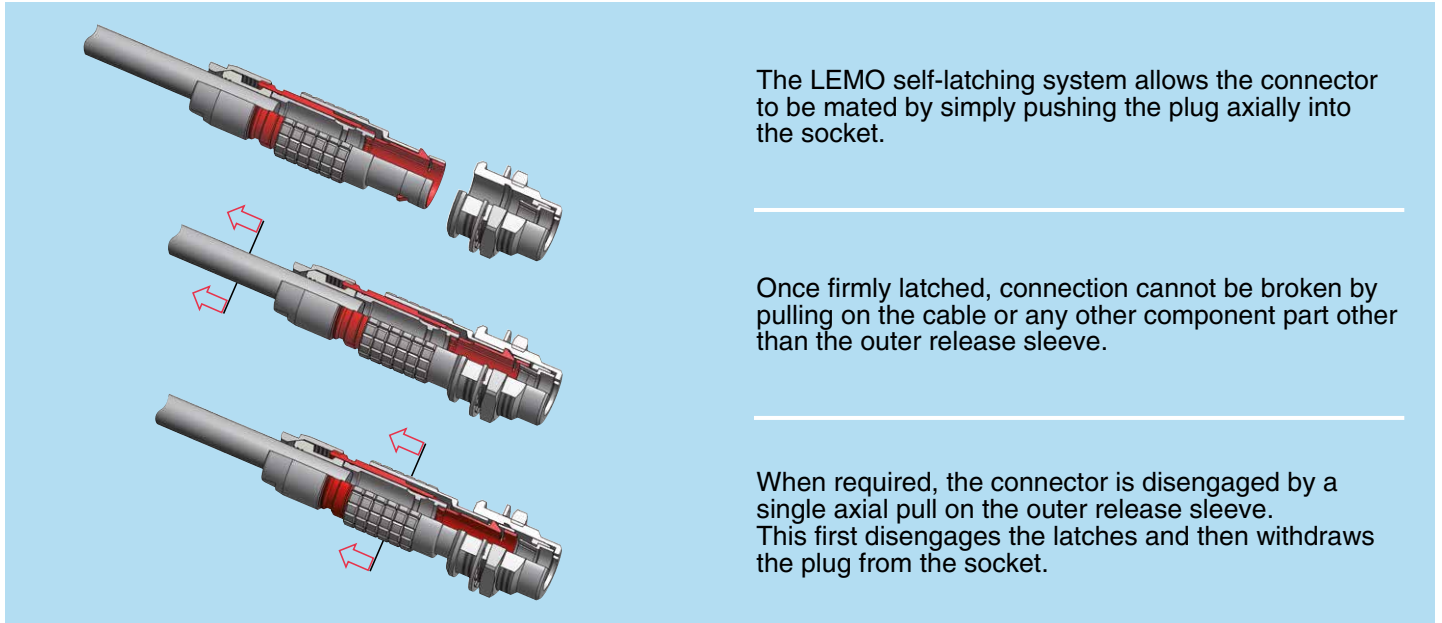

The LEMO self-latching system allows the connector to be mated by simply pushing the plug axially into the socket.



Once firmly latched, connection cannot be broken by pulling on the cable or any other component part other than the outer release sleeve.

When required, the connector is disengaged by a single axial pull on the outer release sleeve. This first disengages the latches and then withdraws the plug from the socket.

## UL Recognition

LEMO connectors are recognized by the Underwriters Laboratories (UL). The approval of the complete system (LEMO connector, cable and your equipment) will be easier because LEMO connectors are recognized.

## CE marking

CE marking  means that the appliance or equipment bearing it complies with the protection requirements of one or several European safety directives. CE marking  applies to complete products or equipment, **but not to electromechanical components, such as connectors.**

## RoHS

LEMO connector specifications conforms the requirements of the RoHS directive (2011/65/EU) of the European Parliament and the latest amendments. This directive specifies the restrictions of the use of hazardous substances in electrical and electronic equipment marketed in Europe.

## Product safety notice & disclaimers

Please read and follow all instructions specified on the last page or on our [website](#) carefully and consult all relevant national and international safety regulations for your application. Improper handling, cable assembly, or wrong use of connectors can result in hazardous situations.

LEMO products and services are provided "as is." LEMO makes no warranties or representations with regard to LEMO product & services or use of them, express, implied or statutory, including for accuracy, completeness, or security.

In no event shall LEMO be liable for any direct, indirect, punitive, incidental, special consequential damages, to property or life, whatsoever arising out of or connected with the use or misuse of LEMO's products.

# T series

T series connectors have been specifically designed for outdoor applications. They include an inner sleeve and seals to prevent penetration of solids or liquids. This series is watertight when mated to give a protection index of IP68 as per IEC 60529 standard and have the following main features:

- IP68 mated
- Push-Pull self-latching system
- Mechanical key (FGG) with multiple keys to avoid cross-mating
- High packing density for space savings
- 360° shielding for full EMC shielding
- Compatible with existing B sockets
- Same mounting hole as B sockets
- Black-chrome plated brass and plastic outershell available
- Multipole types 2 to 32 contacts
- For cables 1.0 up to 10.5 mm
- Solder, crimp or print contacts

## Chrome-plated housing models (page 3)

**Straight plug**

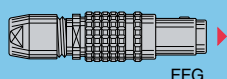

FFG

**Straight plugs**

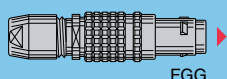

FGG

**Fixed sockets**

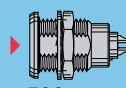

EGG

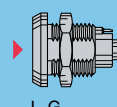

L.G

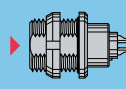

EEG

**Free sockets**

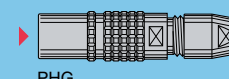

PHG

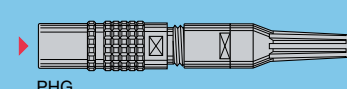

PHG

**Elbow plug**

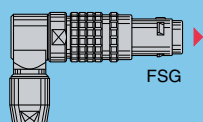

FSG

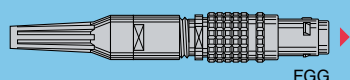

FGG

## Plastic housing models (page 7)

**Straight plug**

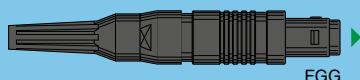

FGG

**Fixed socket**

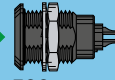

EGG

## Watertight or vacuumtight models (page 6)

**Fixed sockets**

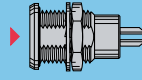

HGG

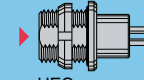

HEG

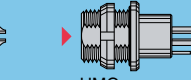

HMG

## Part Section Showing Internal Components

**Fixed socket**

- 1 outer shell
- 2 earthing crown
- 3 hexagonal nut
- 4 insulator
- 5 female contact
- 6 o-ring
- 7 locking washer

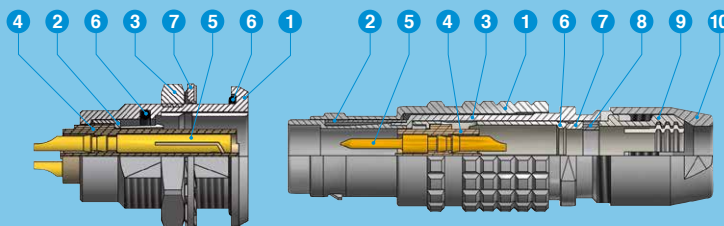

**Straight plug**

- 1 outer shell
- 2 latch sleeve
- 3 inner shell
- 4 insulator
- 5 male contact
- 6 split insert carrier
- 7 earthing cone
- 8 gasket
- 9 collet
- 10 collet nut



## Part Numbering System

### Plug and free socket

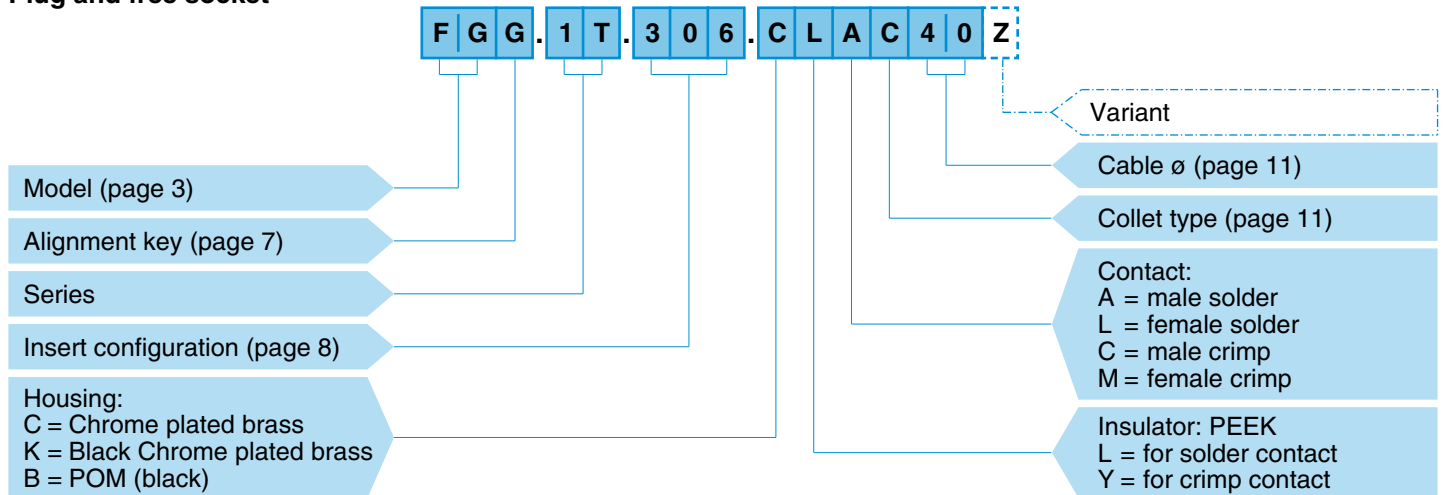

**FGG.1T.306.CLAC40Z** = Straight plug with key (G) and cable collet for bend relief, 1T series, multipole type with 6 contacts, outer shell in chrome-plated brass, PEEK insulator, male solder contacts, C type collet for 4.0 mm diameter cable and nut for fitting a bend relief.

### Fixed socket

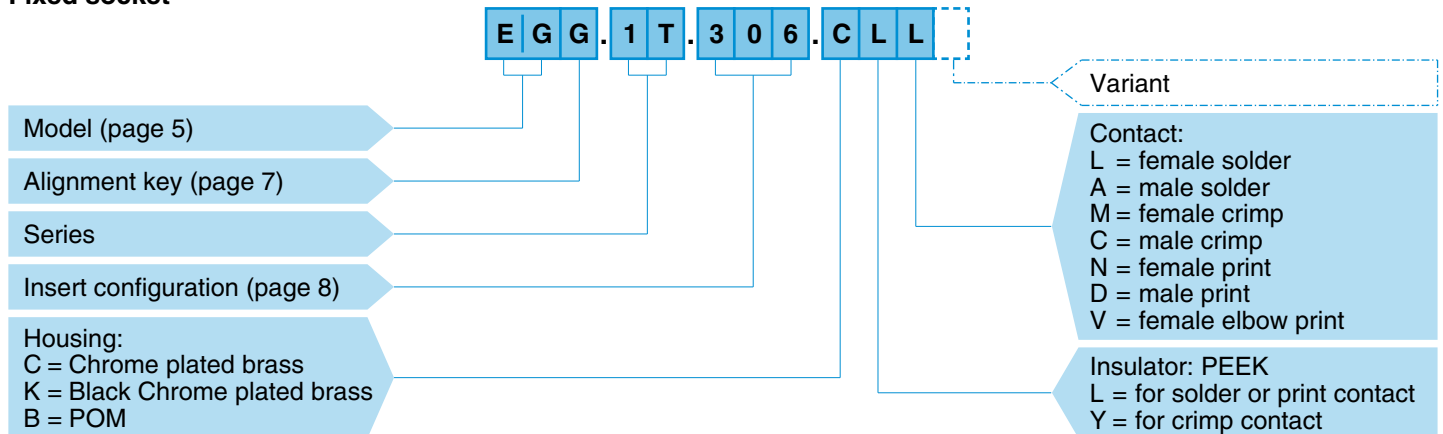

**EGG.1T.306.CLL** = fixed socket, nut fixing, with key (G), 1T series, multipole type with 6 contacts, outer shell in chrome-plated brass, PEEK insulator, female solder contacts.

## Mechanical latching characteristics

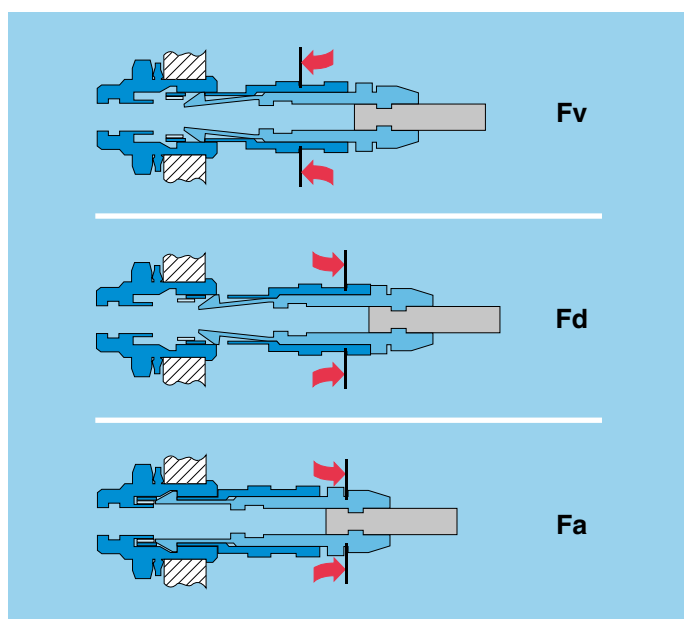

### Keyed watertight series

Force (N)	Series				
	TT	0T	1T	2T	3T
<b>Fv</b>	14	15	16	20	28
<b>Fd</b>	12	13	14	15	24
<b>Fa</b>	80	130	250	250	400

**Notes:** forces were measured on outer shells **not fitted with contacts**.  
**Mechanical endurance:** 3000 cycles. Average pull force (Fa) with axial pull on the collet nut is about 50% of Fa values after 3000 cycles.  
 The values were measured according to the standard IEC 60512-7 test 13a.

1N = 0.102 kg.

Fv: average latching force.

Fd: average unmatting force with axial pull on the outer shell.

Fa: average pull force with axial pull on the collet nut





## Chrome-plated housing models

### Technical Characteristics

#### Contacts

Material	Contact type
Brass (UNS C 34500)	Male contact
Bronze (UNS C 54400)	Female contact

#### Mechanical and Climatical

Characteristics	Value	Standard
Endurance	> 3000 cycles	IEC 60512-5 test 9a
Humidity	up to 95% at 60° C	
Temperature range <sup>1)</sup>	- 55° C, + 200° C / (-20° C, +80° C)	
Resistance to vibration	10-2000 Hz, 15g	IEC 60512-4 test 6d
Shock resistance	100 g, 6 ms	IEC 60512-4 test 6c
Salt spray corrosion test <sup>5)</sup>	> 1000h	IEC 60512-6 test 11f
Protection index (mated) <sup>2)</sup>	IP 68/IP 66	IEC 60529
Latching retention force <sup>3) 4)</sup>	From 85 N up to 300 N	
Climatical category	50/175/21	IEC 60068-1

**Note:** <sup>1)</sup> operating temperature is -20°C, +80°C for watertight or vacuumtight models fitted with an FPM (Viton®) o-ring and Epoxy.  
<sup>2)</sup> IP68 achieved providing that the cable is perfectly circular and that assembly process ensures a high integrity seal.  
<sup>3)</sup> average value.  
<sup>4)</sup> depending of the size.  
<sup>5)</sup> for chrome plated product («C» material code).

#### Electrical

Characteristics	Value	Standard
Shielding efficiency	at 10 MHz	> 75 dB
	at 1 GHz	> 40 dB
		IEC 60169-1-3
		IEC 60169-1-3

**Note:** the various tests have been carried out with FGG and EGG connector pairs, with chrome-plated brass shell and PEEK insulator.

#### Material and treatments

Component	Material	Surface treatment
Outershell and collet nut	Brass	Chrome
	Brass	Black chrome <sup>6)</sup>
	POM	-
Latch sleeve/earthing crown	Brass/Bronze	Nickel
Other metallic components	Brass	Nickel

**Note:** <sup>6)</sup> Surface not conductive use socket with earthing tag (HMG).

### FGG Straight plug, cable collet

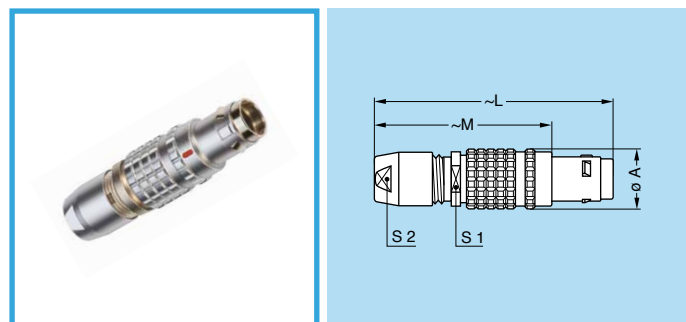

Reference		Dimensions (mm)					Cable ø	
Model	Series	A	L	M	S1	S2	min.	max.
FGG	TT	7.0	33.2	25.2	5.5	5	2.4	3.0
FGG	0T	9.5	39.0	29.0	7.5	7	1.0	5.0
FGG	1T	12.0	46.0	35.0	11.0	9	1.3	6.5
FGG	2T	15.0	55.0	43.0	14.0	12	1.3	8.5
FGG	3T	18.8	64.0	49.0	16.0	14	2.6	10.5

### FGG Straight plug, cable collet and nut for fitting a bend relief

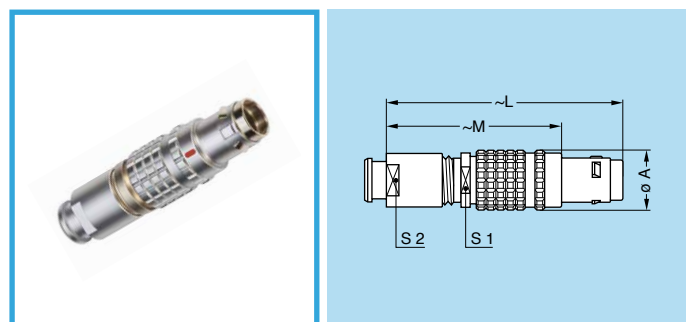

Reference		Dimensions (mm)					Cable ø	
Model	Series	A	L	M	S1	S2	min.	max.
FGG	TT	7.0	32.7	24.7	5.5	6	2.4	3.0
FGG	0T	9.5	38.0	28.0	7.5	7	1.0	5.0
FGG	1T	12.0	45.0	34.0	11.0	9	1.3	6.5
FGG	2T	15.0	54.0	42.0	14.0	12	1.3	8.5
FGG	3T	18.8	62.0	47.0	16.0	15	2.6	10.5

### FFG Straight plug, non latching, cable collet

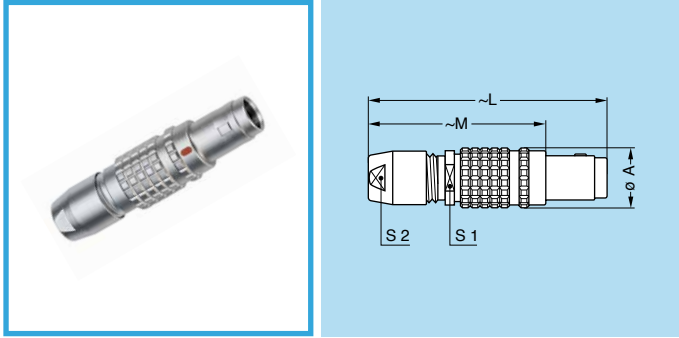

Reference		Dimensions (mm)					Cable ø	
Model	Series	A	L	M	S1	S2	min.	max.
FFG	TT	7.0	33.2	25.2	5.5	5	2.4	3.0
FFG	0T	9.5	39.0	29.0	8.0	7	1.0	5.0
FFG	1T	12.0	46.0	35.0	10.0	9	1.3	6.5
FFG	2T	15.0	55.0	43.0	13.0	12	1.3	8.5
FFG	3T	18.8	64.0	49.0	16.0	14	2.6	10.5

### FSG Adjustable right angle plug

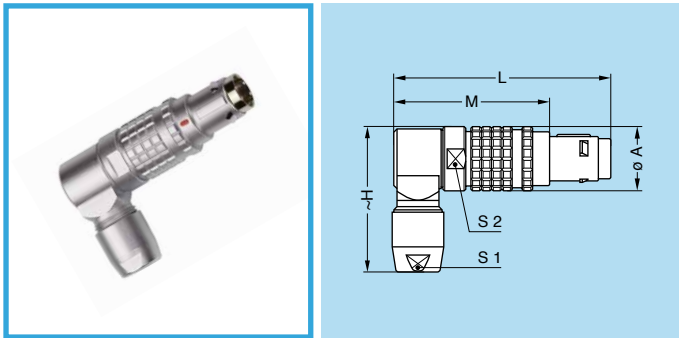

Reference		Dimensions (mm)						Cable ø	
Model	Series	A	H	L	M	S1	S2	min.	max.
FSG	TT	8	20.0	28.5	20.5	5	7.5	2.4	3.0
FSG	0T	10	23.0	36.0	26.0	7	9.5	1.0	5.0
FSG	1T	13	30.0	43.5	32.5	9	12.0	1.3	6.5
FSG	2T	17	37.5	54.0	42.0	12	16.0	1.3	8.5

### PHG Free socket, cable collet

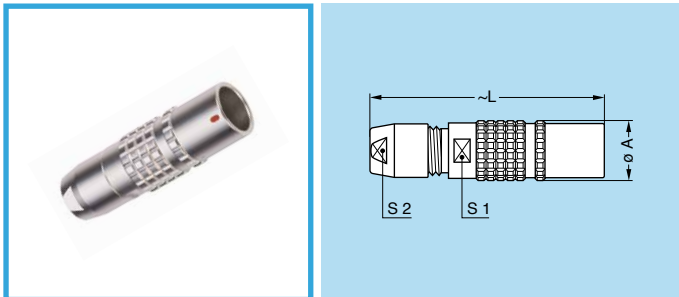

Reference		Dimensions (mm)				Cable ø	
Model	Series	A	L	S1	S2	min.	max.
PHG	TT	7.0	32.0	5.5	5	2.4	3.0
PHG	0T	9.5	38.0	8.0	7	1.0	5.0
PHG	1T	12.0	43.5	10.0	9	1.3	6.5
PHG	2T	15.0	52.0	14.0	12	1.3	8.5
PHG	3T	18.8	61.5	16.0	14	2.6	10.5

### PHG Free socket, cable collet and nut for fitting a bend relief

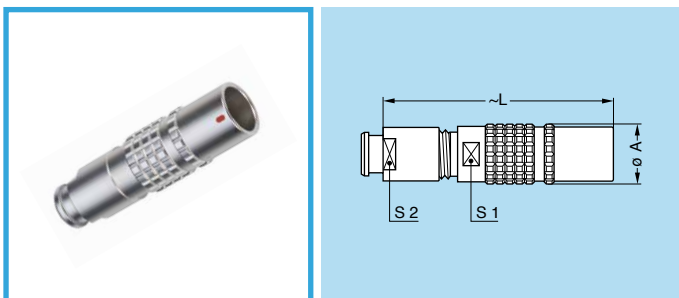

Reference		Dimensions (mm)				Cable ø	
Model	Series	A	L	S1	S2	min.	max.
PHG	TT	7.0	31.5	5.5	6	2.4	3.0
PHG	0T	9.5	37.0	8.0	7	1.0	5.0
PHG	1T	12.0	42.5	10.0	9	1.3	6.5
PHG	2T	15.0	51.0	14.0	12	1.3	8.5
PHG	3T	18.8	60.0	16.0	15	2.6	10.5



### EGG Fixed socket, nut fixing

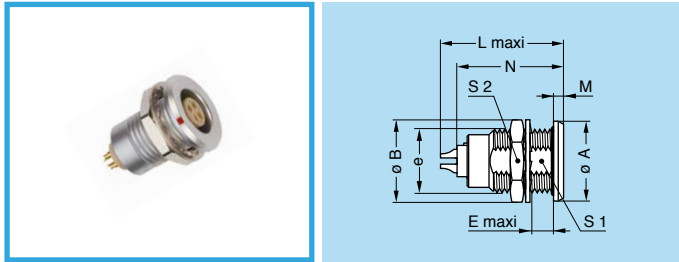

Note: <sup>1)</sup> maximum length with crimp contacts.

Reference		Dimensions (mm)								
Model	Series	A	B	e	E	L	M	N <sup>1)</sup>	S1	S2
EGG	TT	10.0	10.2	M7x0.5	5.5	16.0	1.2	13.5	6.3	9
EGG	0T	12.0	12.5	M9x0.6	6.0	21.0	1.5	19.1	8.2	11
EGG	1T	15.5	16.0	M12x1.0	6.0	23.0	1.8	21.5	10.5	14
EGG	2T	18.5	19.6	M15x1.0	7.5	26.5	1.8	24.6	13.5	17
EGG	3T	23.5	25.1	M18x1.0	9.6	30.1	2.5	25.0	16.5	22

### EEG Fixed socket, nut fixing, back panel mounting

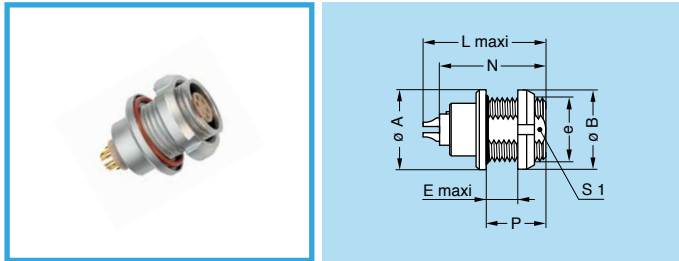

Note: <sup>1)</sup> maximum length with crimp contacts.

Reference		Dimensions (mm)								
Model	Series	A	B	e	E	L	N <sup>1)</sup>	P	S1	
EEG	TT	10.0	10.0	M7x0.5	4.5	16.0	13.5	7	6.3	
EEG	0T	12.0	12.0	M9x0.6	6.5	21.0	19.1	9	8.2	
EEG	1T	15.5	16.0	M12x1.0	6.5	23.0	21.5	10	10.5	
EEG	2T	18.5	20.0	M15x1.0	7.5	26.5	24.6	11	13.5	
EEG	3T	23.5	24.0	M18x1.0	7.5	30.1	25.0	12	16.5	

### Panel cut-out

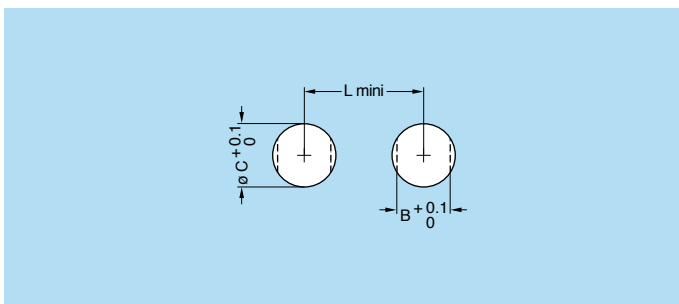

Reference		Panel cut-out			Mounting nut torque (Nm)	
Model	Series	B	C	L	Metal shell	Plastic shell
E●●	TT	6.4	7.1	12.5	1.0	0.4
E●●	0T	8.3	9.1	14.5	2.5	0.4
E●●	1T	10.6	12.1	18.5	4.5	0.7
E●●	2T	13.6	15.1	22.5	6.0	0.8
E●●	3T	16.6	18.1	27.0	9.0	1.0

### LoG Fixed socket, nut fixing, key (G) or keys (A...L)

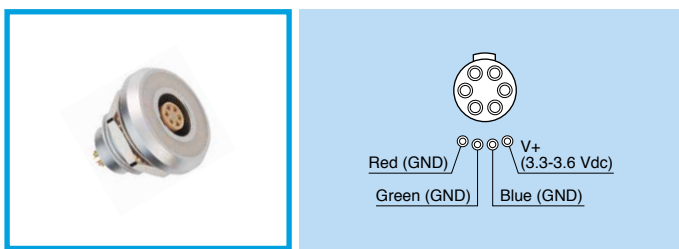

Reference		Dimensions (mm)								
Model	Series	A	B	e	E	L	M	N	S1	S2
LoG	0T	19	18.2	M13x0.75	4.0	18.5	5	16.0	11.5	16
LoG	1T	21	19.2	M15x1.00	5.8	21.0	5	18.5	13.5	17
LoG	2T	25	27.0	M20x1.00	6.5	24.1	5	21.5	18.5	24

Note: Only available with solder or crimp contacts.  
LEG model is with LED flange, LNG model is with narrow LED flange and LMG model is with single standby LED flange.

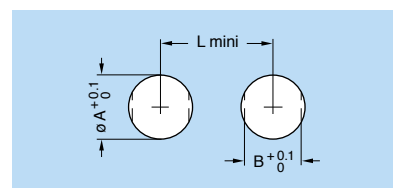
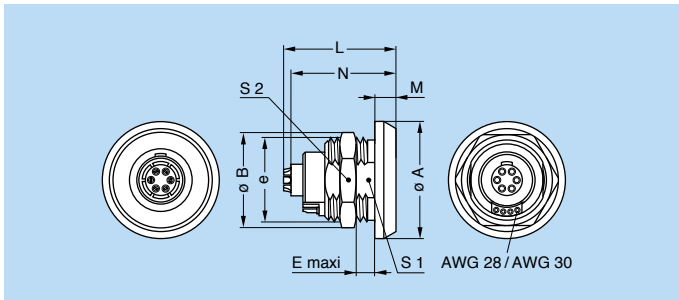

Series	Dim. (mm)		
	A	B	L
0T	13.1	11.6	24
1T	15.1	13.6	26
2T	20.1	18.6	29



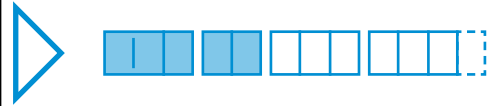

## Watertight or vacuumtight models

These models are identified by a letter «P» at the end of the reference. Most of these models are also available in a vacuumtight version. Such models are identified by an additional letter «V» at the end of the part number (certificate on request). Epoxy resin is used to seal these models. The temperature range is  $-20^{\circ}\text{C} / +80^{\circ}\text{C}$ .

### Part Number Example

HGG.0T.305.CLLP (5 contacts, resin potted)

HGG.0T.305.CLLPV (5 contacts, resin potted and vacuumtight tested)

### HGG Fixed socket, nut fixing, watertight or vacuumtight

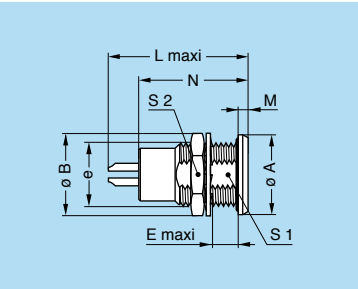

Reference		Dimensions (mm)								
Model	Series	A	B	e	E	L	M	N <sup>1)</sup>	S1	S2
HGG	TT	10.0	10.2	M7x0.5	5.5	18.0	1.2	15.0	6.3	9
HGG	0T	12.0	12.5	M9x0.6	6.5	22.0	1.5	18.5	8.2	11
HGG	1T	15.5	16.0	M12x1.0	6.0	26.0	1.8	21.5	10.5	14
HGG	2T	18.5	19.6	M15x1.0	8.0	30.5	1.8	25.0	13.5	17

### HEG Fixed socket, nut fixing, watertight or vacuumtight, back panel mounting

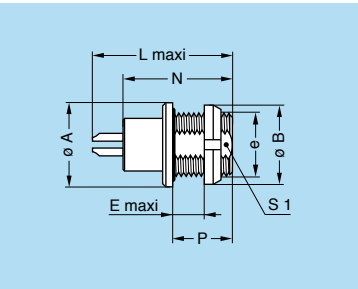

Reference		Dimensions (mm)							
Model	Series	A	B	e	E	L	N	P	S1
HEG	TT	10.0	10.0	M7x0.5	4.5	18.0	15.0	7	6.3
HEG	0T	12.0	12.0	M9x0.6	6.5	22.0	18.5	9	8.2
HEG	1T	15.5	16.0	M12x1.0	6.5	26.0	21.5	10	10.5
HEG	2T	18.5	20.0	M15x1.0	7.5	30.5	25.0	11	13.5

### HMG Fixed socket with earthing tag, nut fixing, watertight or vacuumtight, back panel mounting

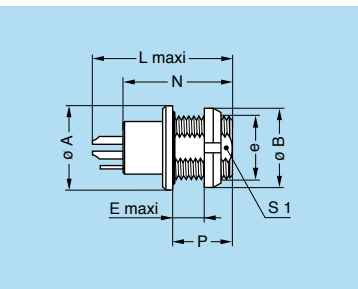

Reference		Dimensions (mm)							
Model	Series	A	B	e	E	L	N	P	S1
HMG	TT	10.0	10.0	M7x0.5	4.5	18.0	15.0	7	6.3
HMG	0T	12.0	12.0	M9x0.6	6.5	22.0	18.5	9	8.2
HMG	1T	15.5	16.0	M12x1.0	6.5	26.0	21.5	10	10.5
HMG	2T	18.5	20.0	M15x1.0	7.5	30.5	25.0	11	13.5

### Panel cut-out

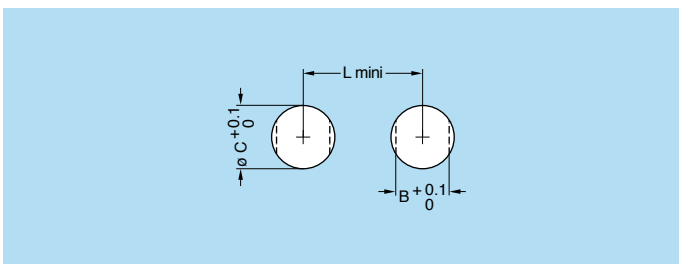

Reference		Panel cut-out			Mounting nut torque (Nm)	
Model	Series	B	C	L	Metal shell	Plastic shell
H●●	TT	6.4	7.1	12.5	1.0	0.4
H●●	0T	8.3	9.1	14.5	2.5	0.4
H●●	1T	10.6	12.1	18.5	4.5	0.7
H●●	2T	13.6	15.1	22.5	6.0	0.8

## Plastic housing models

### FGG Straight plug, cable collet and nut for fitting a bend relief, POM outer shell

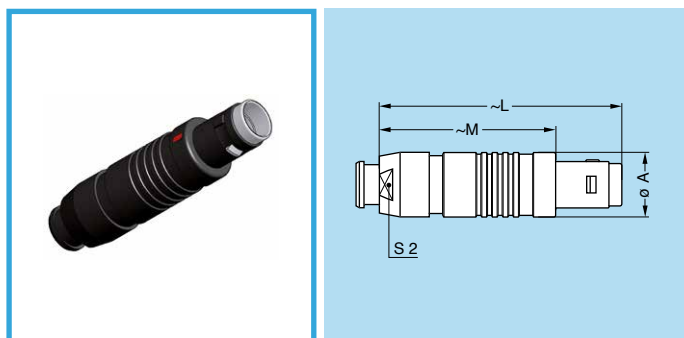

Reference		Dimensions (mm)				Cable $\varnothing$	
Model	Series	A	L	M	S2	min.	max.
FGG	0T	9.7	38.5	28.5	8	1.0	5.0
FGG	1T	13.0	45.0	34.0	10	1.3	6.5

### EGG Fixed socket, nut fixing, POM outer shell

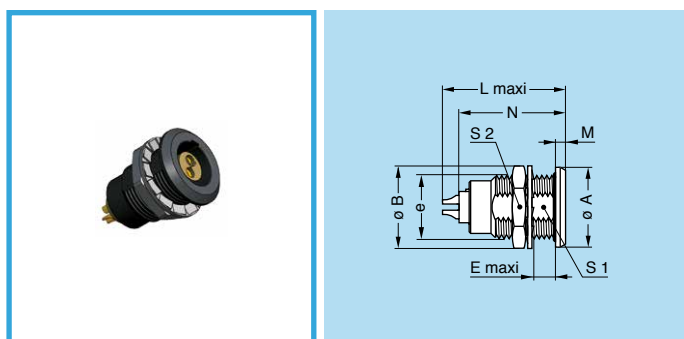

Reference		Dimensions (mm)								
Model	Series	A	B	e	E	L	M	N <sup>1)</sup>	S1	S2
EGG	0T	12.0	12.5	M9x0.6	6.0	21.0	1.5	19.1	8.2	11
EGG	1T	15.5	16.0	M12x1.0	6.0	23.0	1.8	21.5	10.5	14

Note: <sup>1)</sup> maximum length with crimp contacts.

### Panel cut-out

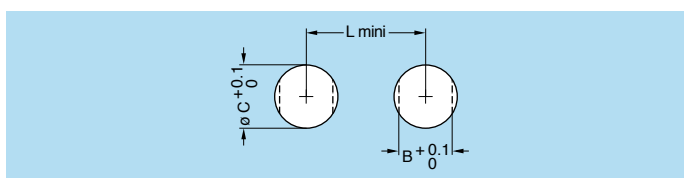

Reference		Panel cut-out		
Model	Series	B	C	L
E●●	0T	8.3	9.1	14.5
E●●	1T	10.6	12.1	18.5

## Alignment Key

	Key	Contact type	
		Plug	Socket
	G	male	female
	A	male	female
	D	male	female
	L	female	male
	J	female	male

Note: <sup>1)</sup> for 2T and 3T series.

# Insert configurations

## Multipole

	Solder contacts		Reference	Series	Contact ø (mm)	Contact type				AWG			Solder contact		Rated current (A)
	Crimp contacts					Solder	Crimp	Print (straight)	Print (elbow)	Solder (max.)	Crimp		Test voltage (kV rms) Contact-contact	Test voltage (kV rms) Contact-shell	
	min.	max.													
2			302	TT	0.5	●	●	●	●	30	32	28	1.00	0.95	3.5
				0T	0.9	●	●	●	●	20	32	20	1.00	1.05	10.0
				1T	1.3	●	●	●	●	20	26	18	1.50	1.35	15.0
				2T	2.0	●	●	●	●	16	18	12	2.10	1.75	25.0
				3T	3.0	●	●	○	–	12	14	10	2.10	1.55	35.0
3			303	TT	0.5	●	●	●	●	30	32	28	0.80	0.95	3.0
				0T	0.9	●	●	●	●	20	32	20	1.20	0.90	8.0
				1T	1.3	●	●	●	●	20	26	18	1.30	1.55	12.0
				2T	1.6	●	●	●	●	18	22	14	2.40	1.85	17.0
				3T	2.0	●	●	●	○	16	18	12	1.90	1.50	25.0
4			304	TT	0.5	●	●	●	●	30	32	28	0.80	0.65	2.0
				0T	0.7	●	●	●	●	22	32	22	0.85	0.70	7.0
				1T	0.9	●	●	●	●	22	32	20	1.35	1.45	10.0
				2T	1.3	●	●	●	●	20	26	18	1.85	1.85	15.0
				3T	2.0	●	●	●	●	16	18	12	1.45	1.25	19.0
5			305	TT	0.35	●	–	●	–	30	–	–	0.70	1.00	1.7
5						305	0T	0.7	●	●	●	●	22	32	22
1T	0.9	●	●				●	●	22	32	20	1.25	1.15	9.0	
2T	1.3	●	●				●	●	20	26	18	1.75	1.60	14.0	
3T	1.6	●	●				●	●	18	22	14	1.90	1.25	19.0	
6			306	0T	0.5	●	○ <sup>1)</sup>	●	●	28	32	28	0.85	0.65	2.5
				1T	0.7	●	●	●	●	22	32	22	1.05	1.20	7.0

Note: 1) available only for connectors fitted with male contacts.

● First choice alternative ○ Special order alternative





## Multipole

			Reference	Series	Contact ø (mm)	Contact type				AWG		Solder contact		Rated current (A)	
						Solder	Crimp	Print (straight)	Print (elbow)	Solder (max.)	Crimp		Test voltage (kV rms) Contact-contact		Test voltage (kV rms) Contact-shell
											min.	max.			
6			306	TT	0.35	●	-	-	-	30	-	-	0.60	0.75	1.5
				2T	1.3	●	●	●	●	20	26	18	1.35	1.45	12.0
				3T	1.6	●	●	●	●	18	22	14	1.60	1.15	17.0
7			307	0T	0.5	●	○ <sup>1)</sup>	●	●	28	32	28	0.80	0.70	2.5
				1T	0.7	●	●	●	●	22	32	22	0.95	1.05	7.0
				2T	1.3	●	●	●	●	20	26	18	1.75	1.60	11.0
				3T	1.6	●	●	●	○	18	22	14	1.70	1.25	15.0
8			308	1T	0.7	●	●	●	●	22	32	22	0.95	1.15	5.0
				2T	0.9	●	●	●	●	22	32	20	1.50	1.25	10.0
8			308	3T	1.3	●	●	●	●	20	26	18	1.65	1.15	13.0
				9			309	0T	0.5	●	○ <sup>1)</sup>	●	●	28	32
3T	8x1.3 1x2.0	●	●	●				-	20 16	26 18	18 12	1.35	1.05	6.0 15.0	
10			310	1T	0.5	●	● <sup>1)</sup>	●	●	28	32	28	0.90	1.50	2.5
				2T	0.9	●	●	●	●	22	32	20	1.45	1.30	8.0
				3T	1.3	●	●	●	●	20	26	18	1.25	0.90	12.0
12			312	0T	0.35	●	-	●	-	30	-	-	0.80	1.00	1.5
				2T	0.7	●	●	●	●	22	32	22	1.25	1.35	7.0
12			312	3T	0.9	●	●	●	●	22	32	20	1.45	1.00	9.0
				14			314	1T	0.5	●	● <sup>1)</sup>	●	●	28	32
2T	0.7	●	●					●	●	22	32	22	1.15	1.35	6.5
3T	0.9	●	●					●	●	22	32	20	1.20	1.20	9.0

Note: <sup>1)</sup> available only for connectors fitted with male contacts.

● First choice alternative ○ Special order alternative

## Multipole

	Solder contacts		Crimp contacts		Reference	Series	Contact ø (mm)	Contact type				AWG		Solder contact		Rated current (A)	
								Solder	Crimp	Print (straight)	Print (elbow)	Solder (max.)	Crimp		Test voltage (kV rms) Contact-contact		Test voltage (kV rms) Contact-shell
													min.	max.			
16			316	1T	0.5	●	● <sup>1)</sup>	●	○	28	32	28	0.80	1.25	1.5		
				2T	0.7	●	●	●	●	22	32	22	0.95	1.25	6.0		
16			316	3T	0.9	●	●	●	●	22	32	20	1.20	0.85	8.0		
				2T	0.7	●	●	●	●	22	32	22	0.85	1.20	5.5		
18			318	3T	0.9	●	●	●	●	22	32	20	1.20	1.05	7.0		
				2T	0.7	●	●	●	●	22	32	22	0.95	1.25	5.0		
19			319	2T	0.7	●	●	●	●	22	32	22	0.95	1.25	5.0		
20			320	3T	0.7	●	●	●	●	22	32	22	1.00	0.90	6.0		
22			322	3T	0.7	●	●	●	○	22	32	22	1.00	0.90	5.5		
24			324	3T	0.7	●	●	●	●	22	32	22	0.95	0.80	4.0		
26			326	2T	0.5	●	-	●	●	28	-	-	0.95	1.30	2.0		
				3T	0.7	●	●	●	●	22	32	22	0.95	0.70	4.0		
30			330	3T	0.7	●	●	●	●	22	32	22	0.80	0.70	3.5		
32			332	2T	0.5	●	-	●	●	28	-	-	0.80	1.20	1.5		

Note: <sup>1)</sup> available only for connectors fitted with male contacts.

● First choice alternative ○ Special order alternative

# Collets

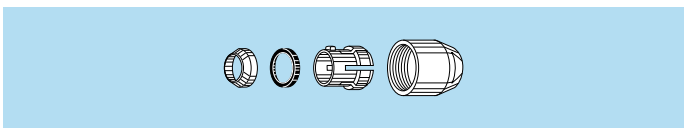

	Type	Cable $\phi$ (mm)		Note
		min.	max.	
<b>TT</b>	<b>C27</b>	2.4	2.6	
	<b>C31</b>	2.7	3.0	
<b>OT</b>	<b>C10</b>	1.0	1.2	1)
	<b>C15</b>	1.3	1.5	1)
	<b>C20</b>	1.6	2.0	1)
	<b>C25</b>	2.1	2.5	
	<b>C30</b>	2.6	3.0	
	<b>C35</b>	3.1	3.5	
	<b>C40</b>	3.6	4.0	
	<b>C45</b>	4.1	4.5	
	<b>K50</b>	4.6	5.0	2)
	<b>K55</b>	5.1	5.5	2)
	<b>K60</b>	5.6	6.0	2)
<b>1T</b>	<b>C15</b>	1.3	1.5	
	<b>C20</b>	1.6	2.0	
	<b>C25</b>	2.1	2.5	
	<b>C30</b>	2.6	3.0	
	<b>C35</b>	3.1	3.5	
	<b>C40</b>	3.6	4.0	
	<b>C45</b>	4.1	4.5	
	<b>C50</b>	4.6	5.0	
	<b>C55</b>	5.1	5.5	
	<b>C60</b>	5.6	6.0	
	<b>C65</b>	6.1	6.5	
<b>K70</b>	6.6	7.0	3)	
<b>K75</b>	7.1	7.5	3)	
<b>K80</b>	7.6	8.0	3)	
<b>K85</b>	8.1	8.5	3)	

	Type	Cable $\phi$ (mm)		Note
		min.	max.	
<b>2T</b>	<b>C15</b>	1.3	1.5	
	<b>C20</b>	1.6	2.0	
	<b>C25</b>	2.1	2.5	
	<b>C30</b>	2.6	3.0	
	<b>C35</b>	3.1	3.5	
	<b>C40</b>	3.6	4.0	
	<b>C45</b>	4.1	4.5	
	<b>C50</b>	4.6	5.0	
	<b>C55</b>	5.1	5.5	
	<b>C60</b>	5.6	6.0	
	<b>C65</b>	6.1	6.5	
	<b>C70</b>	6.6	7.0	
	<b>C75</b>	7.1	7.5	
	<b>C80</b>	7.6	8.0	
	<b>C85</b>	8.1	8.5	
	<b>K90</b>	8.6	9.0	4)
<b>K95</b>	9.1	9.5	4)	
<b>K10</b>	9.6	10.0	4)	
<b>K11</b>	10.1	10.5	4)	

	Type	Cable $\phi$ (mm)		Note
		min.	max.	
<b>3T</b>	<b>C30</b>	2.6	3.0	
	<b>C35</b>	3.1	3.5	
	<b>C40</b>	3.6	4.0	
	<b>C45</b>	4.1	4.5	
	<b>C50</b>	4.6	5.0	
	<b>C55</b>	5.1	5.5	
	<b>C60</b>	5.6	6.0	
	<b>C65</b>	6.1	6.5	
	<b>C70</b>	6.6	7.0	
	<b>C75</b>	7.1	7.5	
	<b>C80</b>	7.6	8.0	
	<b>C85</b>	8.1	8.5	
	<b>C90</b>	8.6	9.0	
	<b>C95</b>	9.1	9.5	
	<b>C10</b>	9.6	10.0	
<b>C11</b>	10.1	10.5		
<b>K11</b>	10.6	12.0		
<b>K12</b>	12.1	12.8		
<b>K13</b>	12.9	13.5		
<b>K14</b>	13.6	14.0		
<b>K15</b>	14.1	15.0	5)	

**Note:** all dimensions are in millimetres.  
 1) the inner diameter of the smallest bend relief available is 2.5 mm (in TPU) / 1.7 mm (in silicone).  
 2) for 1B bend relief.  
 3) for 2B bend relief.  
 4) for 3B bend relief.  
 5) the inner diameter of the largest bend relief available is 14.5 mm.



## Spare parts for crimp contacts

	Types	Insulator part number		ø (mm)		F <sub>0</sub>	Cond. AWG		Contact part number		
		Male contact	Female contact	A	C		min.	max.	Male	Female	
<b>TT</b>	<b>302/303/304</b>	FGG.00.30●.YL	EGG.00.40●.YL	0.5	0.45	1	32	28	FGG.00.554.ZZC	EGG.00.654.ZZM	
<b>OT</b>	<b>302/303</b>	FGG.0B.30●.YL	EGG.0B.40●.YL	0.9		1.10	1	24	20	FGG.0B.560.ZZC	EGG.0B.660.ZZM
						0.80	2	26	22	FGG.0B.561.ZZC	EGG.0B.661.ZZM
						0.45	2	32	28	FGG.0B.562.ZZC	EGG.0B.662.ZZM
	<b>304/305</b>	FGG.0B.30●.YL	EGG.0B.40●.YL	0.7		0.80	1	26	22	FGG.0B.555.ZZC	EGG.0B.655.ZZM
					0.45	2	32	28	FGG.0B.556.ZZC	EGG.0B.656.ZZM	
<b>306/307/309</b>	FGG.0B.30●.YL	–	0.5	0.45	1	32	28	FGG.0B.554.ZZC	–		
<b>1T</b>	<b>302/303</b>	FGG.1B.30●.YL	EGG.1B.40●.YL	1.3		1.40	1	20	18	FGG.1B.565.ZZC	EGG.1B.665.ZZM
						1.10	2	24	20	FGG.1B.566.ZZC	EGG.1B.666.ZZM
	<b>304/305</b>	FGG.1B.30●.YL	EGG.1B.40●.YL	0.9		1.10	1	24	20	FGG.1B.560.ZZC	EGG.1B.660.ZZM
						0.80	2	26	22	FGG.1B.561.ZZC	EGG.1B.661.ZZM
	<b>306/307/308</b>	FGG.1B.30●.YL	EGG.1B.40●.YL	0.7		0.80	1	26	22	FGG.1B.555.ZZC	EGG.1B.655.ZZM
						0.45	2	32	28	FGG.1B.556.ZZC	EGG.1B.656.ZZM
	<b>310/314/316</b>	FGG.1B.3●●.YL	–	0.5	0.45	1	32	28	FGG.1B.554.ZZC	–	
	<b>2T</b>	<b>302</b>	FGG.2B.302.YL	EGG.2B.402.YL	2.0		2.40	1	16	12	FGG.2B.575.ZZC
1.90							2	18	14	FGG.2B.576.ZZC	EGG.2B.676.ZZM
<b>303</b>		FGG.2B.303.YL	EGG.2B.403.YL	1.6		1.90	1	18	14	FGG.2B.570.ZZC	EGG.2B.670.ZZM
						1.40	2	22	18	FGG.2B.571.ZZC	EGG.2B.671.ZZM
<b>304/305 306/307</b>		FGG.2B.30●.YL	EGG.2B.40●.YL	1.3		1.40	1	20	18	FGG.2B.565.ZZC	EGG.2B.665.ZZM
						1.10	2	24	20	FGG.2B.566.ZZC	EGG.2B.666.ZZM
						0.80	2	26	22	FGG.2B.567.ZZC	EGG.2B.667.ZZM
<b>308/310</b>		FGG.2B.3●●.YL	EGG.2B.4●●.YL	0.9		1.10	1	24	20	FGG.2B.560.ZZC	EGG.2B.660.ZZM
						0.80	2	26	22	FGG.2B.561.ZZC	EGG.2B.661.ZZM
						0.45	2	32	28	FGG.2B.562.ZZC	EGG.2B.662.ZZM
<b>312/314/316 318/319</b>		FGG.2B.3●●.YL	EGG.2B.4●●.YL	0.7		0.80	1	26	22	FGG.2B.555.ZZC	EGG.2B.655.ZZM
						0.45	2	32	28	FGG.2B.556.ZZC	EGG.2B.656.ZZM
<b>3T</b>	<b>302</b>	FGG.3B.302.YL	EGG.3B.402.YL	3.0	3.20	1	14	10	FGG.3B.580.ZZC	EGG.3B.680.ZZM	
	<b>303/304/309</b>	FGG.3B.30●.YL <sup>1)</sup>	EGG.3B.40●.YL <sup>1)</sup>	2.0		2.40	1	16	12	FGG.3B.575.ZZC	EGG.3B.675.ZZM
						1.90	2	18	14	FGG.3B.576.ZZC	EGG.3B.676.ZZM
	<b>305/306/307</b>	FGG.3B.30●.YL	EGG.3B.40●.YL	1.6		1.90	1	18	14	FGG.3B.570.ZZC	EGG.3B.670.ZZM
						1.40	2	22	18	FGG.3B.571.ZZC	EGG.3B.671.ZZM
	<b>308/309/310</b>	FGG.3B.3●●.YL <sup>1)</sup>	EGG.3B.4●●.YL <sup>1)</sup>	1.3		1.40	1	20	18	FGG.3B.565.ZZC	EGG.3B.665.ZZM
						1.10	2	24	20	FGG.3B.566.ZZC	EGG.3B.666.ZZM
						0.80	2	26	22	FGG.3B.567.ZZC	EGG.3B.667.ZZM
	<b>312/314 316/318</b>	FGG.3B.3●●.YL	EGG.3B.4●●.YL	0.9		1.10	1	24	20	FGG.3B.560.ZZC	EGG.3B.660.ZZM
						0.80	2	26	22	FGG.3B.561.ZZC	EGG.3B.661.ZZM
						0.45	2	32	28	FGG.3B.562.ZZC	EGG.3B.662.ZZM
	<b>320/322/324 326/330</b>	FGG.3B.3●●.YL	EGG.3B.4●●.YL	0.7		0.80	1	26	22	FGG.3B.555.ZZC	EGG.3B.655.ZZM
0.45						2	32	28	FGG.3B.556.ZZC	EGG.3B.656.ZZM	

**Note:** <sup>1)</sup> for 309 type the insulator part number is FGG.3B.309.ML (male contact) and EGG.3B.409.ML (female contact).

## Tools for crimp contacts

	Types	Positioners part number		Extractors part number for male/female contacts
		Male contact	Female contact	
<b>TT</b>	<b>302/303/304</b>	DCE.91.050.0VC	DCE.91.050.0VM	DCF.91.050.2LT
<b>OT</b>	<b>302/303</b>	DCE.91.090.BVC	DCE.91.090.BVM	DCF.91.090.2LT
		DCE.91.090.AVC	DCE.91.090.AVM	
	<b>304/305</b>	DCE.91.070.BVC	DCE.91.070.BVM	DCF.92.070.3LT
	<b>306/307/309</b>	DCE.91.050.BVC	DCE.91.050.BVM	DCF.91.050.2LT
<b>1T</b>	<b>302/303</b>	DCE.91.131.BVC	DCE.91.131.BVM	DCF.91.131.2LT
	<b>304/305</b>	DCE.91.091.BVC	DCE.91.091.BVM	DCF.91.090.2LT
	<b>306/307/308</b>	DCE.91.071.BVC	DCE.91.071.BVM	DCF.91.070.2LT
	<b>310/314/316</b>	DCE.91.051.BVC	DCE.91.051.BVM	DCF.91.050.2LT
<b>2T</b>	<b>302</b>	DCE.91.202.BVCM		DCC.91.202.5LA <sup>2)</sup>
	<b>303</b>	DCE.91.162.BVCM		DCF.91.162.2LT
	<b>304/305 306/307</b>	DCE.91.132.BVC	DCE.91.132.BVM	DCF.91.131.2LT
		DCE.91.132.CVC	DCE.91.132.CVM	
	<b>308/310</b>	DCE.91.092.BVC	DCE.91.092.BVM	DCF.91.090.2LT
		DCE.91.092.AVC	DCE.91.092.AVM	
<b>312/314/316 318/319</b>	DCE.91.072.BVC	DCE.91.072.BVM	DCF.91.070.2LT	
<b>3T</b>	<b>302</b>	DCE.91.303.BVCM		DCF.91.303.5LT
	<b>303/304/309</b>	DCE.91.203.BVCM		DCC.91.202.5LA <sup>2)</sup>
	<b>305/306/307</b>	DCE.91.163.BVCM		DCF.91.163.5LT
	<b>308/309/310</b>	DCE.91.133.BVC	DCE.91.133.BVM	DCF.91.133.5LT
	<b>312/314 316/318</b>	DCE.91.093.BVC	DCE.91.093.BVM	DCF.91.093.5LT
		DCE.91.093.BVG	DCE.91.093.BVU	
<b>320/322/324 326/330</b>	DCE.91.073.BVC	DCE.91.073.BVM	DCF.92.070.3LT	

**Note:** <sup>2)</sup> this model is thumb-operated.

### FGG-EGG Crimp contacts

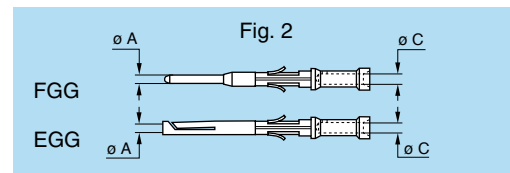
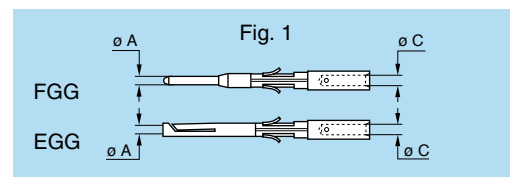

**Note:** a wide variation of strand number and diameter combinations are quoted as being AWG, some of which do not have a large enough cross section to guarantee a crimp as per either MIL-C-22520/1-01 or /7-01.

### FGG-EGG Insulators



**Note:** each insulator can be used both for crimp contacts of normal shape (fig. 1) or with reduced solder cups (fig. 2).

### DCE Positioners ø 0.5, 0.7, 0.9, 1.3 mm



These positioners are suitable for use with both manual and pneumatic crimping tools according to the MIL-C-22520/7-01 standard.

### DCE Turret for ø 1.6, 2.0, 3.0, 4.0 mm



**Note:** these turrets can be used with manual crimping tool according to MIL-C-22520/1-01 standard.

### DCF Automatic extraction tools

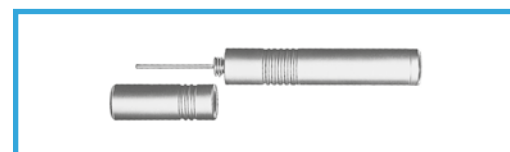

## Spare parts

### GBA Locking washers

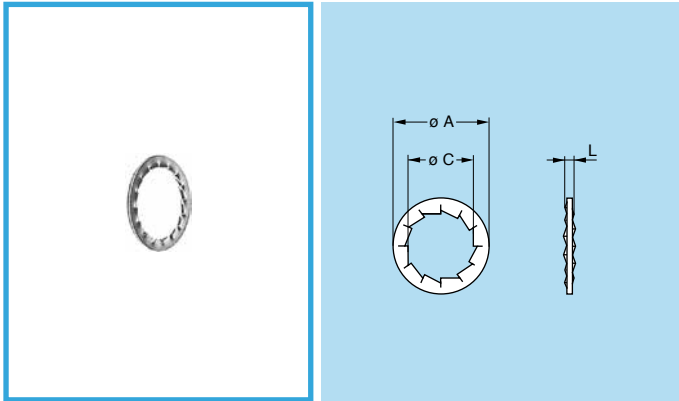

Part number	Series	Dimensions (mm)		
		A	C	L
<b>GBA.00.250.FN</b>	TT	9.5	7.1	1.0
<b>GBA.0S.250.FN</b>	0T	12.5	9.1	1.0
<b>GBA.1S.250.FN</b>	1T	16.0	12.1	1.0
<b>GBA.2S.250.FN</b>	2T	19.5	15.1	1.2
<b>GBA.3S.250.FN</b>	3T	25.0	18.1	1.4

**Note:** to order this accessory separately, use the above part numbers.

- Material: Nickel-plated bronze (3  $\mu$ m)

### GEA Hexagonal nuts

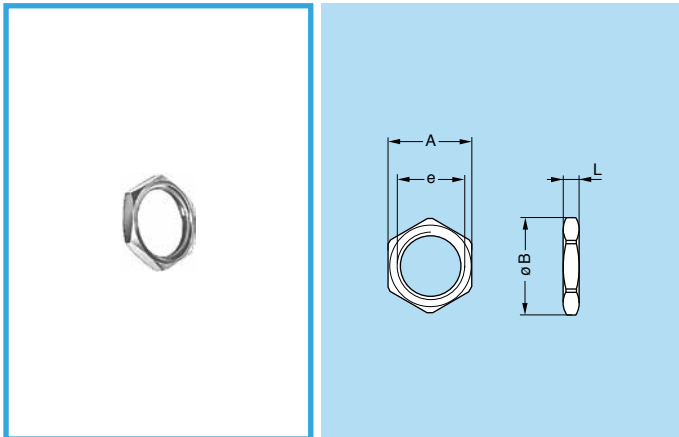

Part number	Series	Dimensions (mm)			
		A	B	e	L
<b>GEA.00.240.LN</b>	TT	9	10.2	M7 x 0.5	2.0
<b>GEA.0S.240.LN</b>	0T	11	12.4	M9 x 0.6	2.0
<b>GEA.1S.240.LN</b>	1T	14	15.8	M12 x 1.0	2.5
<b>GEA.2S.240.LN</b>	2T	17	19.2	M15 x 1.0	2.7
<b>GEA.3S.240.LN</b>	3T	22	25.0	M18 x 1.0	3.0

**Note:** to order this part separately, use the above part numbers. The last letters «LN» of the part number refer to the nut material and treatment. If a nut in aluminium alloy or stainless steel is desired, replace the last letters of the part number by «PT» or «AZ» respectively. See page 18 for the tooling.

- Material: Nickel-plated brass (3  $\mu$ m), Natural anodized aluminium alloy, Stainless steel

### GEC Conical nuts

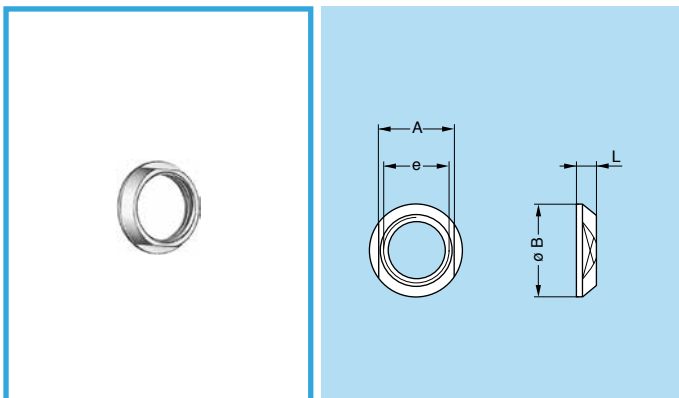

Part number	Series	Dimensions (mm)			
		A	B	e	L
<b>GEC.00.240.LC</b>	TT	8	10	M7 x 0.5	2.5
<b>GEC.0S.240.LC</b>	0T	10	12	M9 x 0.6	2.5
<b>GEC.1S.240.LC</b>	1T	13	16	M12 x 1.0	3.2
<b>GEC.2S.240.LC</b>	2T	17	20	M15 x 1.0	3.8
<b>GEC.3S.240.LC</b>	3T	20	24	M18 x 1.0	4.5

**Note:** 3T series fixed and free sockets for back panel mounting are always delivered with a conical nut. To order this accessory separately, use the above part numbers. See page 18 for the tooling.

- Material: Chrome-plated brass (Ni 3  $\mu$ m + Cr 0.3  $\mu$ m)

## GEG Notched nuts

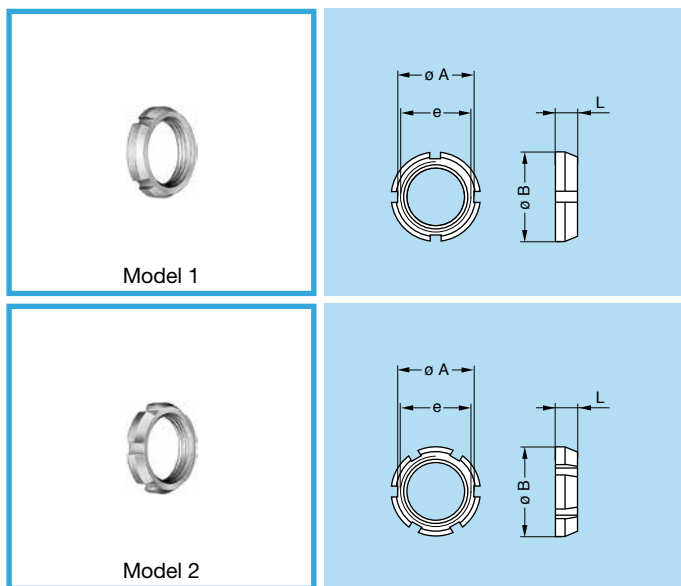

Part number	Series	Dimensions (mm)				Model
		A	B	e	L	
<b>GEG.00.240.LC</b>	TT	8.6	10	M7 x 0.5	2.5	1
<b>GEG.0S.240.LC</b>	0T	10.5	12	M9 x 0.6	2.5	1
<b>GEG.1S.240.LC</b>	1T	14.0	16	M12 x 1.0	3.5	1
<b>GEG.2S.240.LC</b>	2T	17.5	20	M15 x 1.0	3.5	2

**Note:** TT, 0T, 1T and 2T series fixed and free sockets for back panel mounting are always delivered with this notched nut. To order this accessory separately, use the above part numbers. See page 19 for the tooling.

- Material: Chrome-plated brass (Ni 3 µm + Cr 0.3 µm)

# Accessories

## BFG Blanking caps for plugs

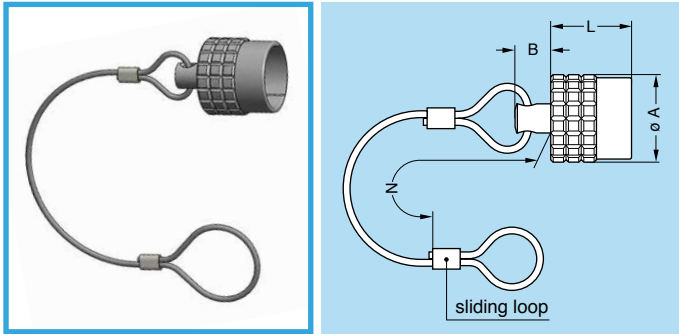

## BHG Blanking caps for fixed plugs

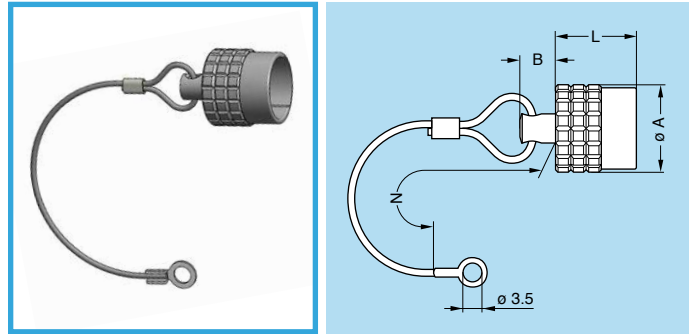

Part number	Dimensions (mm)				Part number
	A	B	L	N <sup>1)</sup>	
<b>BFG.TT.100.CAS</b>	7.0	4.3	9.0	60	<b>BHG.TT.100.CAS</b>
<b>BFG.0T.100.CAS</b>	9.5	5.0	11.0	85	<b>BHG.0T.100.CAS</b>
<b>BFG.1T.100.CAS</b>	12.0	6.3	12.4	85	<b>BHG.1T.100.CAS</b>
<b>BFG.2T.100.CAS</b>	15.0	6.4	13.8	85	<b>BHG.2T.100.CAS</b>
<b>BFG.3T.100.CAS</b>	18.8	6.4	17.6	120	<b>BHG.3T.100.CAS</b>

- Body material: Chrome-plated brass (Ni 3 µm)
- Lanyard material: Stainless steel
- Crimp ferrule material: Nickel-plated brass + polyolefin
- O-ring material: Silicone
- Operating temperature: -50°/135°C (Silicone rubber & Polyolefine)
- Watertightness: IP68 according to IEC 60529

**Note:** 1) the tolerance on this dimension is ± 5 mm.

## BRF Blanking caps for free sockets

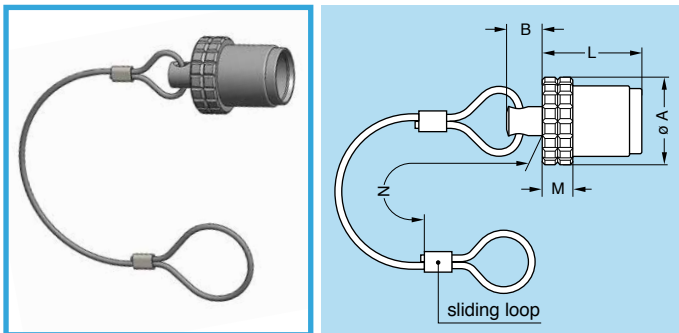

## BRE Blanking caps for sockets

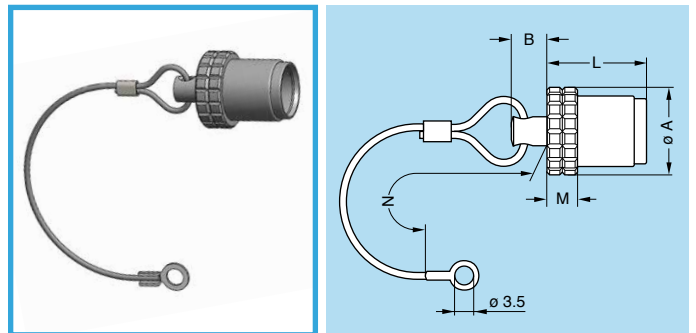

Part number	Dimensions (mm)					Part number
	A	B	L	M	N <sup>1)</sup>	
<b>BRF.TT.200.CAZ</b>	7.0	4.3	10.4	2.4	60	<b>BRE.TT.200.CAZ</b>
<b>BRF.0T.200.CAZ</b>	9.5	5.0	13.2	3.2	85	<b>BRE.0T.200.CAZ</b>
<b>BRF.1T.200.CAZ</b>	12.0	6.3	15.1	4.2	85	<b>BRE.1T.200.CAZ</b>
<b>BRF.2T.200.CAZ</b>	15.0	6.4	17.1	5.2	85	<b>BRE.2T.200.CAZ</b>
<b>BRF.3T.200.CAZ</b>	18.8	6.4	21.2	6.4	120	<b>BRE.3T.200.CAZ</b>

- Body material: Chrome-plated brass (Ni 3 µm)
- Lanyard material: Stainless steel
- Crimp ferrule material: Nickel-plated brass + polyolefin
- Operating temperature: -50°/135°C (Silicone rubber & Polyolefine)
- Watertightness: IP68 according to IEC 60529

**Note:** 1) the tolerance on this dimension is ± 5 mm.

## GCA Earthing washers

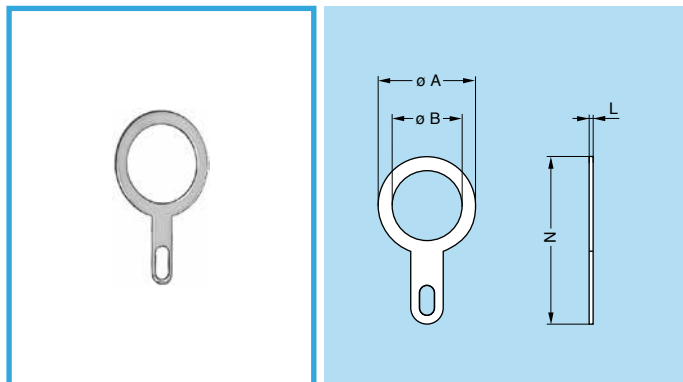

Part number	Series	Dimensions (mm)			
		A	B	L	N
<b>GCA.00.255.LT</b>	TT	9.5	7.1	0.4	18.2
<b>GCA.0S.255.LT</b>	0T	13.0	9.1	0.4	22.0
<b>GCA.1S.255.LT</b>	1T	17.0	12.2	0.5	27.5
<b>GCA.2S.255.LT</b>	2T	20.0	15.2	0.5	32.0
<b>GCA.3S.255.LT</b>	3T	25.0	18.2	0.5	39.0

● Material: CuSnZn plated brass (2 µm)

## Bend relief (TPU)

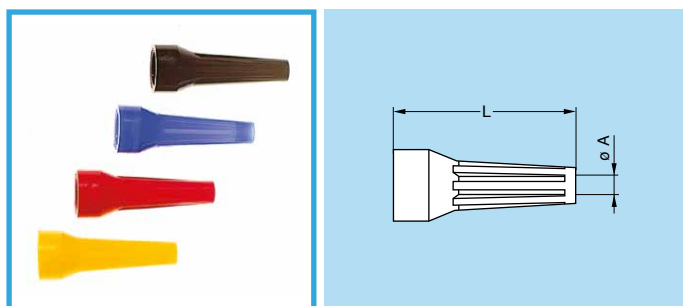

A bend relief made from thermoplastic polyurethane elastomer can be fitted over LEMO plugs and sockets that are supplied with nut for fitting such bend relief. They are available in nine different colours match with the GRA insulating washers. Use the part numbers shown below to order this accessory separately.

	Part number	Bend relief		Cable $\phi$	
		A	L	min.	max.
<b>TT</b>	<b>GMB.00.025.DG</b> <sup>1)</sup>	2.5	22	2.5	2.8
	<b>GMB.00.028.DG</b> <sup>1)</sup>	2.8	22	2.8	3.1
	<b>GMB.00.032.DG</b> <sup>1)</sup>	3.2	22	3.2	3.5
	<b>GMD.00.025.DG</b> <sup>1)</sup>	2.5	22	2.5	2.8
	<b>GMD.00.028.DG</b> <sup>1)</sup>	2.8	22	2.8	3.1
	<b>GMD.00.032.DG</b> <sup>1)</sup>	3.2	22	3.2	3.5
<b>0T</b>	<b>GMA.0B.025.DG</b>	2.5	24	2.5	2.9
	<b>GMA.0B.030.DG</b>	3.0	24	3.0	3.4
	<b>GMA.0B.035.DG</b>	3.5	24	3.5	3.9
	<b>GMA.0B.040.DG</b> <sup>1)</sup>	4.0	24	4.0	4.4
	<b>GMA.0B.045.DG</b> <sup>1)</sup>	4.5	24	4.5	5.2
<b>1T</b>	<b>GMA.1B.025.DG</b>	2.5	30	2.5	2.9
	<b>GMA.1B.030.DG</b>	3.0	30	3.0	3.4
	<b>GMA.1B.035.DG</b>	3.5	30	3.5	3.9
	<b>GMA.1B.040.DG</b>	4.0	30	4.0	4.4
	<b>GMA.1B.045.DG</b>	4.5	30	4.5	4.9
	<b>GMA.1B.054.DG</b>	5.4	30	5.4	6.0
	<b>GMA.1B.065.DG</b> <sup>1)</sup>	6.5	30	6.5	7.0

	Part number	Bend relief		Cable $\phi$	
		A	L	min.	max.
<b>2T</b>	<b>GMA.2B.040.DG</b>	4.0	36	4.0	4.5
	<b>GMA.2B.045.DG</b>	4.5	36	4.5	5.0
	<b>GMA.2B.050.DG</b>	5.0	36	5.0	5.5
	<b>GMA.2B.060.DG</b>	6.0	36	6.0	6.5
	<b>GMA.2B.070.DG</b>	7.0	36	7.0	7.7
	<b>GMA.2B.080.DG</b> <sup>1)</sup>	7.8	36	7.8	8.8
<b>3T</b>	<b>GMA.3B.050.DG</b> <sup>1)</sup>	4.5	42	4.5	5.2
	<b>GMA.3B.060.DG</b>	6.0	42	6.0	6.9
	<b>GMA.3B.070.DG</b>	7.0	42	7.0	7.9
	<b>GMA.3B.080.DG</b>	8.0	42	8.0	8.9
	<b>GMA.3B.090.DG</b>	9.0	42	9.0	10.0

**Note:** all dimensions are in millimetres.

Ref.	Colour	Ref.	Colour	Ref.	Colour
<b>A</b>	blue	<b>J</b>	yellow	<b>R</b>	red
<b>B</b>	white	<b>M</b>	brown	<b>S</b>	orange
<b>G</b>	grey	<b>N</b>	black	<b>V</b>	green

**Note:** <sup>1)</sup> Design may differ from other bend relief, model without stripes. The «GMD» are thin bend reliefs (for very flexible cables). The last letter «G» of the part number indicates the grey colour of the bend relief. For ordering a bend relief with another colour, see table above and replace the letter «G» by the letter of the required colour.



# Tooling

## DCG Spanners for hexagonal nuts

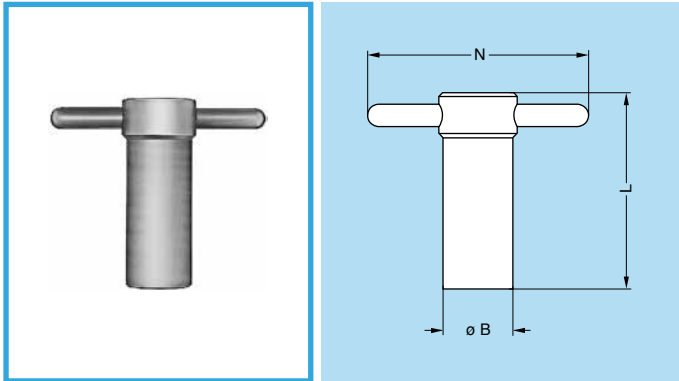

Part number	Series	Dimensions (mm)			Part number of the nut
		B	L	N	
<b>DCG.91.149.0TN</b>	TT	14	40	50	GEA.00.240.LN
<b>DCG.91.161.1TN</b>	0T	16	45	52	GEA.0S.240.LN
<b>DCG.91.201.4TN</b>	1T	20	52	65	GEA.1S.240.LN
<b>DCG.91.231.7TN</b>	2T	23	62	68	GEA.2S.240.LN
<b>DCG.91.282.2TN</b>	3T	28	76	73	GEA.3S.240.LN

● Material: blackened steel

## DCA Spanners for hexagonal nuts with locator for flats on socket thread

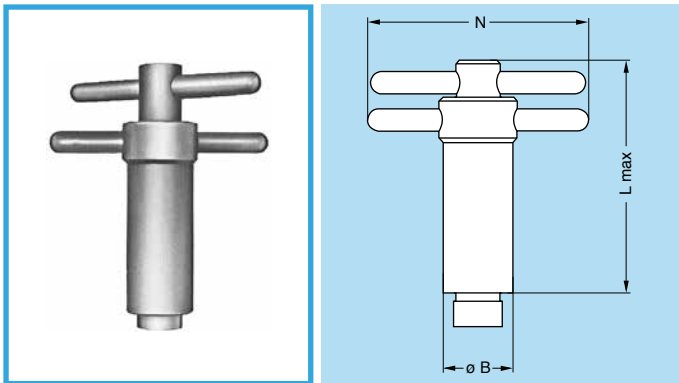

Part number	Series	Dimensions (mm)			Part number of the nut
		B	L	N	
<b>DCA.91.149.0TN</b>	TT	14	65	50	GEA.00.240.LN
<b>DCA.91.161.1TN</b>	0T	16	73	52	GEA.0S.240.LN
<b>DCA.91.201.4TN</b>	1T	20	85	65	GEA.1S.240.LN
<b>DCA.91.231.7TN</b>	2T	23	100	68	GEA.2S.240.LN
<b>DCA.91.282.2TN</b>	3T	28	120	73	GEA.3S.240.LN

● Material: blackened steel

## DCH Spanners for conical nuts

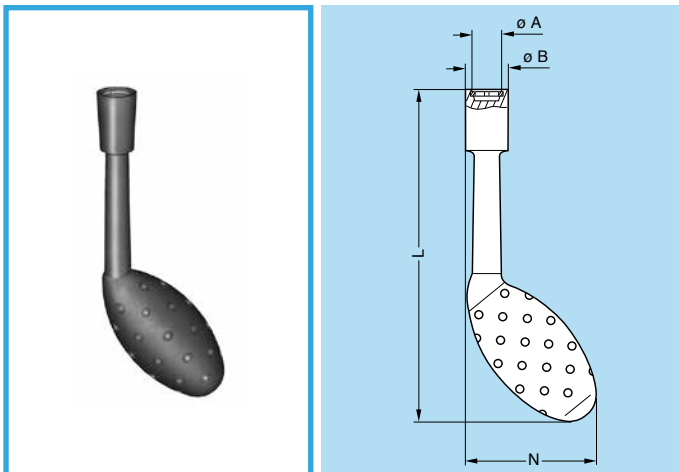

Part number	Series	Dimensions (mm)				Part number of the nut
		A	B	L	N	
<b>DCH.91.101.PN</b>	TT	10.1	12.8	124	48.3	GEC.00.240.LC
<b>DCH.91.121.PN</b>	0T	12.1	14.8	124	49.3	GEC.0S.240.LC
<b>DCH.91.161.PN</b>	1T	16.1	21.0	124	51.9	GEC.1S.240.LC
<b>DCH.91.201.PN</b>	2T	20.1	22.8	129	53.5	GEC.2S.240.LC

● Material: dark grey polyurethane

## DCH Spanners for notched nuts

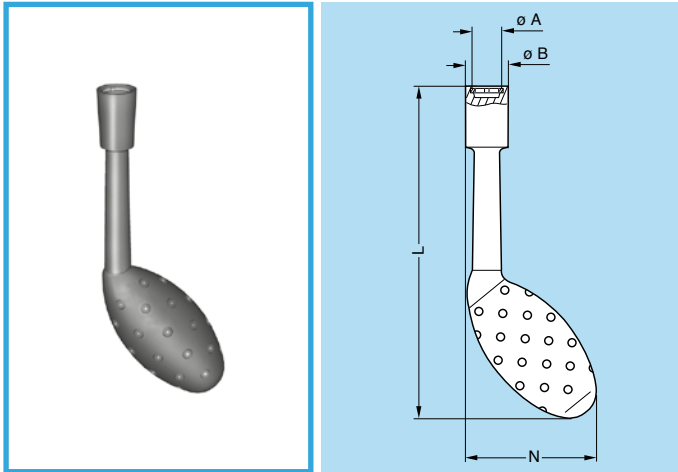

Part number	Series	Dimensions (mm)				Part number of the nut
		A	B	L	N	
<b>DCH.91.101.PA</b>	TT	10.1	12.8	124	48.3	GEG.00.240.LC
<b>DCH.91.121.PA</b>	0T	12.1	14.8	124	49.3	GEG.0S.240.LC
<b>DCH.91.161.PA</b>	1T	16.1	21.0	124	51.9	GEG.1S.240.LC
<b>DCH.91.201.PA</b>	2T	20.1	22.8	129	53.5	GEG.2S.240.LC

● Material: blue polyurethane

## DCP Flat spanners for collet nut

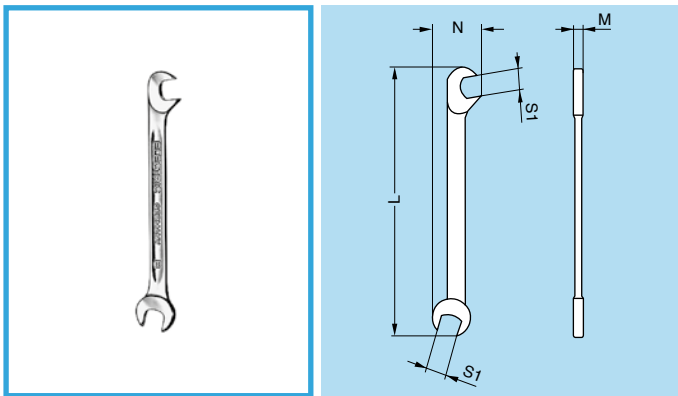

Part number	Series	Dimensions (mm)			
		L	M	N	S1
<b>DCP.99.050.TC</b>	TT	78	2	12.6	5.0
<b>DCP.99.055.TC</b>	TT	78	2	12.6	5.5
<b>DCP.99.060.TC</b>	TT	78	2	12.6	6.0

● Material: chrome-plated steel

## DCP Set of flat spanners for collet nuts

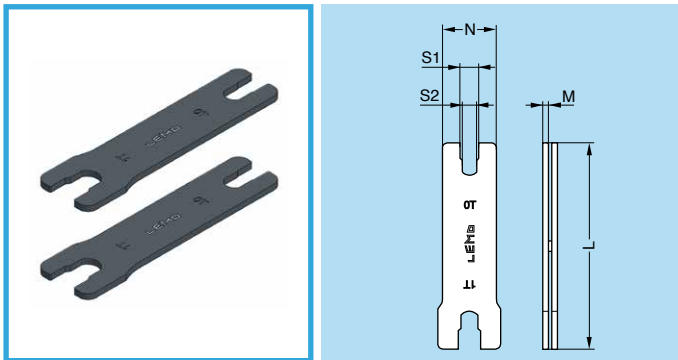

Part number	Series	Dimensions (mm)				
		L	M	N	S1	S2
<b>DCP.0T.110.TN</b>	0T	95	2.5	21	7.55	7.05
<b>DCP.0T.110.TN</b>	1T	95	2.5	25	11.05	9.05
<b>DCP.2T.110.TN</b>	2T	115	3.0	30	14.05	12.05
<b>DCP.2T.110.TN</b>	3T	115	3.0	35	16.05	14.05

● Material: blackened steel

## DCP Set of flat spanners for FS● retaining ring & collet nuts

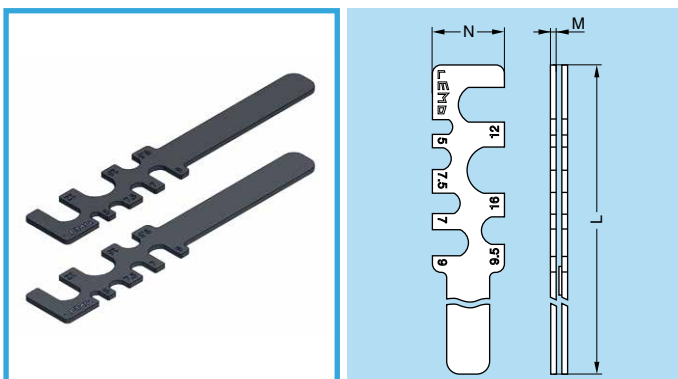

Part number	Series	Dimensions (mm)		
		L	M	N
<b>DCP.TT.FSG.TN</b>	TT-0T-1T-2T	152	2	25

● Material: blackened steel

# Crimping tools for electrical contacts

## Manual crimping tools

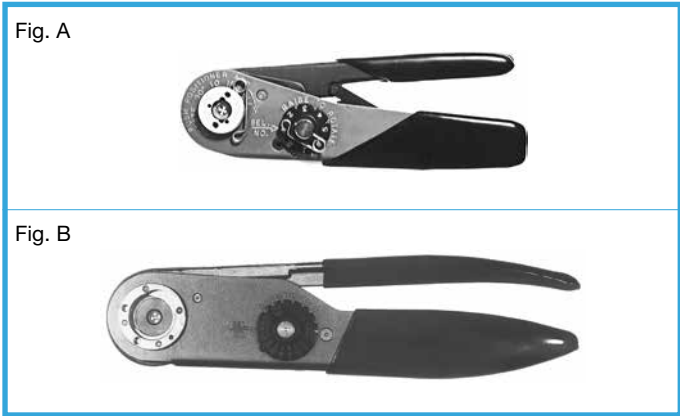

Part number		Supplier
contact ø 0.5-0.7 0.9-1.3 (Fig. A)	contact ø 1.6-2.0 (Fig. B)	
<b>DPC.91.701.V<sup>1)</sup></b>	<b>DPC.91.101.A<sup>2)</sup></b>	LEMO
<b>MH860<sup>1)</sup></b>	<b>AF8<sup>2)</sup></b>	DANIELS
<b>616336<sup>1)</sup></b>	<b>615708<sup>2)</sup></b>	ASTRO

<sup>1)</sup> According to specification MIL-C-22520/7-01.  
<sup>2)</sup> According to specification MIL-C-22520/1-01.

## Pneumatic crimping tools



Part number	Supplier
<b>DPC.91.701.C</b>	LEMO
<b>85230</b>	BALMAR
<b>621101</b>	BUCHANAN

According to specification MIL-C-22520/7-01.  
 For LEMO contacts ø 0.5-0.7-0.9-1.3 mm

# PCB drilling pattern

## Fixed socket with straight print contact

302

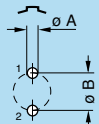

Series	Dimensions	
	A	B
<b>TT</b>	0.6	1.2
<b>0T</b>	0.8	2.2
<b>1T</b>	0.8	2.8
<b>2T</b>	0.8	4.4

303

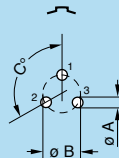

Series	Dimensions		
	A	B	C
<b>TT</b>	0.6	1.35	120°
<b>0T</b>	0.8	2.30	120°
<b>1T</b>	0.8	3.00	120°
<b>2T</b>	0.8	4.60	120°
<b>3T</b>	0.8	5.60	120°

304

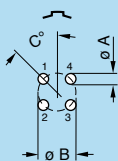

Series	Dimensions		
	A	B	C
<b>TT</b>	0.6	1.6	45°
<b>0T</b>	0.6	2.5	45°
<b>1T</b>	0.8	3.1	45°
<b>2T</b>	0.8	5.0	45°
<b>3T</b>	0.8	6.2	45°

305

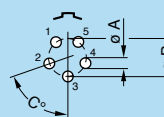

Series	Dimensions		
	A	B	C
<b>TT</b>	0.5	1.7	72°

305

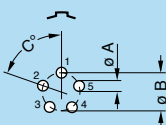

Series	Dimensions		
	A	B	C
<b>0T</b>	0.6	2.8	72°
<b>1T</b>	0.8	3.4	72°
<b>2T</b>	0.8	5.2	72°
<b>3T</b>	0.8	6.7	72°

306

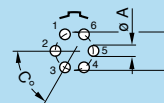

Series	Dimensions		
	A	B	C
<b>0T</b>	0.6	3.0	60°
<b>1T</b>	0.8	3.7	60°

306

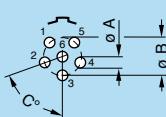

Series	Dimensions		
	A	B	C
<b>2T</b>	0.8	5.6	72°
<b>3T</b>	0.8	7.1	72°

307

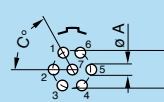

Series	Dimensions		
	A	B	C
<b>0T</b>	0.6	3.00	60°
<b>1T</b>	0.8	3.70	60°
<b>2T</b>	0.8	5.80	60°
<b>3T</b>	0.8	7.08	60°

308

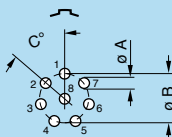

Series	Dimensions		
	A	B	C
<b>1T</b>	0.8	3.8	51°26'

308

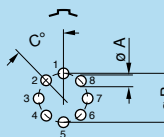

Series	Dimensions		
	A	B	C
<b>2T</b>	0.8	6.4	45°
<b>3T</b>	0.8	7.5	45°

309

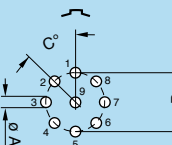

Series	Dimensions		
	A	B	C
<b>0T</b>	0.6	3.2	45°
<b>3T</b>	0.8	7.5	45°

310

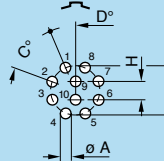

Series	Dimensions				
	A	B	C	D	H
<b>1T</b>	0.6	3.95	45°	22°30'	1.40
<b>2T</b>	0.8	6.30	45°	22°30'	2.15
<b>3T</b>	0.8	7.90	45°	22°30'	2.80

**Note:** all views are from the side of the socket.

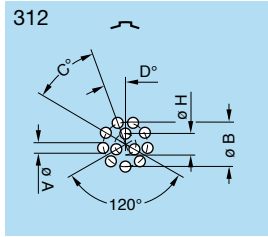

Series	Dimensions				
	A	B	C	D	H
<b>0T</b>	0.5	3.3	40°	20°	1.25

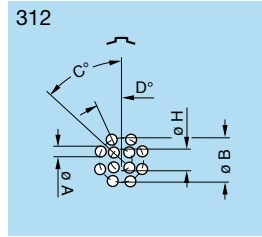

Series	Dimensions				
	A	B	C	D	H
<b>2T</b>	0.8	6.50	45°	22°30'	2.80
<b>3T</b>	0.8	8.20	45°	22°30'	3.40

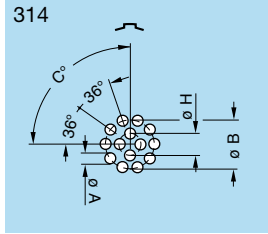

Series	Dimensions			
	A	B	C	H
<b>1T</b>	0.6	4.4	90°	1.90
<b>2T</b>	0.8	6.5	90°	2.65
<b>3T</b>	0.8	8.2	90°	3.40

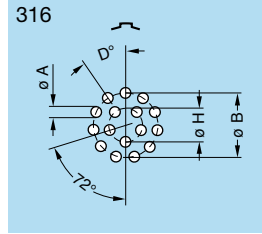

Series	Dimensions			
	A	B	D	H
<b>1T</b>	0.6	4.4	32°44'	2.0

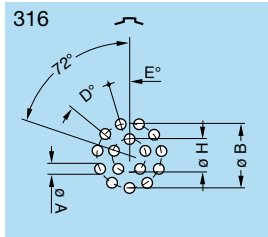

Series	Dimensions				
	A	B	D	E	H
<b>2T</b>	0.8	6.6	32°44'	16°22'	3.10
<b>3T</b>	0.8	8.4	32°44'	16°22'	3.86

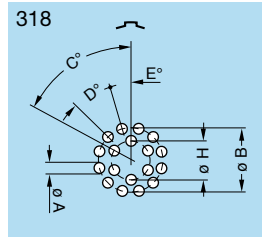

Series	Dimensions					
	A	B	C	D	E	H
<b>2T</b>	0.8	6.7	60°	30°	15°	3.50
<b>3T</b>	0.8	8.4	60°	30°	15°	4.34

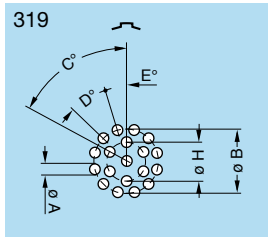

Series	Dimensions					
	A	B	C	D	E	H
<b>2T</b>	0.8	6.7	60°	30°	15°	3.5

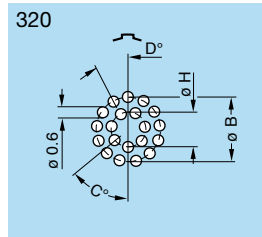

Series	Dimensions			
	B	C	D	H
<b>3T</b>	8.62	51°26'	27°42'	4.78

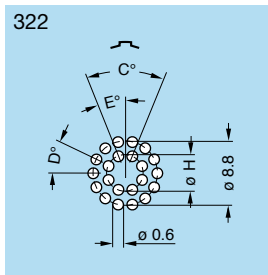

Series	Dimensions			
	C	D	E	H
<b>3T</b>	45°	25°43'	22°30'	5

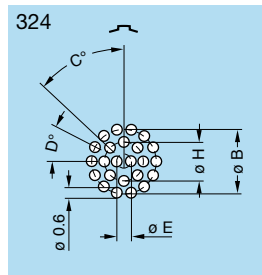

Series	Dimensions				
	B	C	D	E	H
<b>3T</b>	8.8	45°	25°43'	1.8	5.30

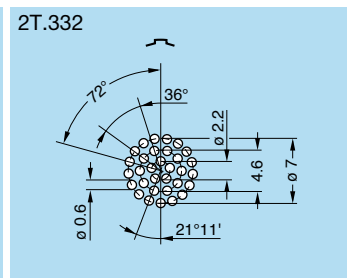
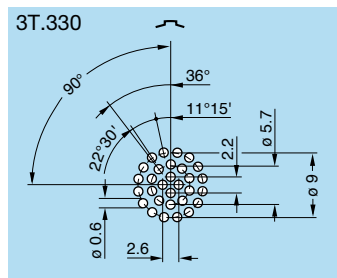
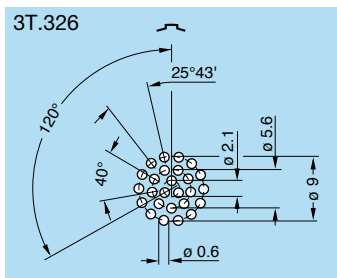
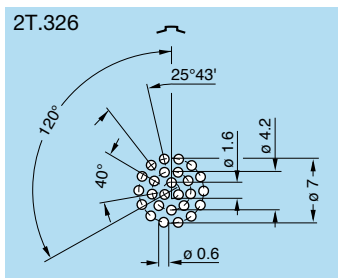

**Note:** all views are from the side of the socket.

### Metal collet nut tightening torque

Series	Maximum metal collet nut tightening torque (Nm)
<b>TT</b>	0.25
<b>0T</b>	0.70

Series	Maximum metal collet nut tightening torque (Nm)
<b>1T</b>	0.80
<b>2T</b>	2.00

Series	Maximum metal collet nut tightening torque (Nm)
<b>3T</b>	3.00

## Cable assembly

### Straight plugs and sockets with cable collet

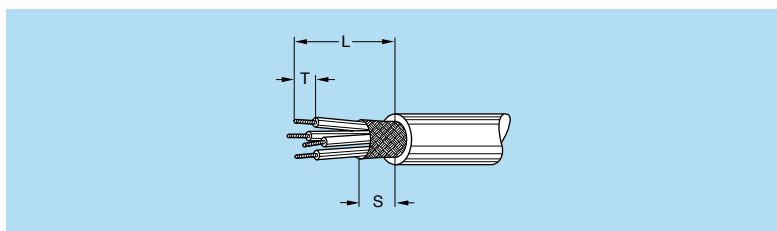

	Type	ø contact A (mm)	Cable stripping lengths (mm)					
			Solder			Crimp		
			L	S	T	L	S	T
<b>TT</b>	<b>302/303/304</b>	0.5	7.0	4	2.5	10.0	4	3.0
	<b>305/306</b>	0.35	7.0	4	2.5	-	-	-
<b>OT</b>	<b>302/303</b>	0.9	9.5	6	3.5	12.0	6	4.0
	<b>304/305</b>	0.7	9.5	6	3.5	12.0	6	4.0
	<b>306/307/309<sup>1)</sup></b>	0.5	9.0	6	2.5	13.0	6	3.0
	<b>312</b>	0.35	9.0	6	2.5	-	-	-
<b>1T</b>	<b>302/303</b>	1.3	11.0	7	3.5	14.5	7	4.0
	<b>304/305</b>	0.9	11.0	7	3.0	14.5	7	4.0
	<b>306/307/308</b>	0.7	11.0	7	3.0	14.5	7	4.0
	<b>310/314/316</b>	0.5	13.0	7	2.5	14.0	7	3.0
<b>2T</b>	<b>302</b>	2.0	16.5	8	4.0	19.5	8	5.5
	<b>303</b>	1.6	16.5	8	3.5	19.5	8	5.5
	<b>304/305/306/307</b>	1.3	15.5	8	3.5	17.5	8	4.0
	<b>308/310</b>	0.9	14.5	8	3.0	17.5	8	4.0
	<b>312/314/316/318/319</b>	0.7	14.5	8	3.0	17.5	8	4.0
	<b>326/332</b>	0.5	14.5	8	2.5	-	-	-
<b>3T</b>	<b>302</b>	3.0	19.0	10	4.5	23.0	10	5.5
	<b>303/304</b>	2.0	18.0	10	4.0	22.0	10	5.5
	<b>305/306/307</b>	1.6	18.0	10	3.5	22.0	10	5.5
	<b>308/310</b>	1.3	17.0	10	3.5	20.0	10	4.0
	<b>309</b>	1.3 2.0	17.0	10	3.5 4.0	20.0	10	4.0 5.5
	<b>312/314/316/318</b>	0.9	16.0	10	3.0	20.0	10	4.0
	<b>320/322/324/326/330</b>	0.7	16.0	10	3.0	20.0	10	4.0

**Note:**

<sup>1)</sup> crimp contacts are available only for connectors fitted with male contacts. The tolerances on these dim. are: L: ± 0.5 mm; S: ± 0.5 mm; T: ± 0.2 mm.



## Terminating plugs with solder contacts and cable collet

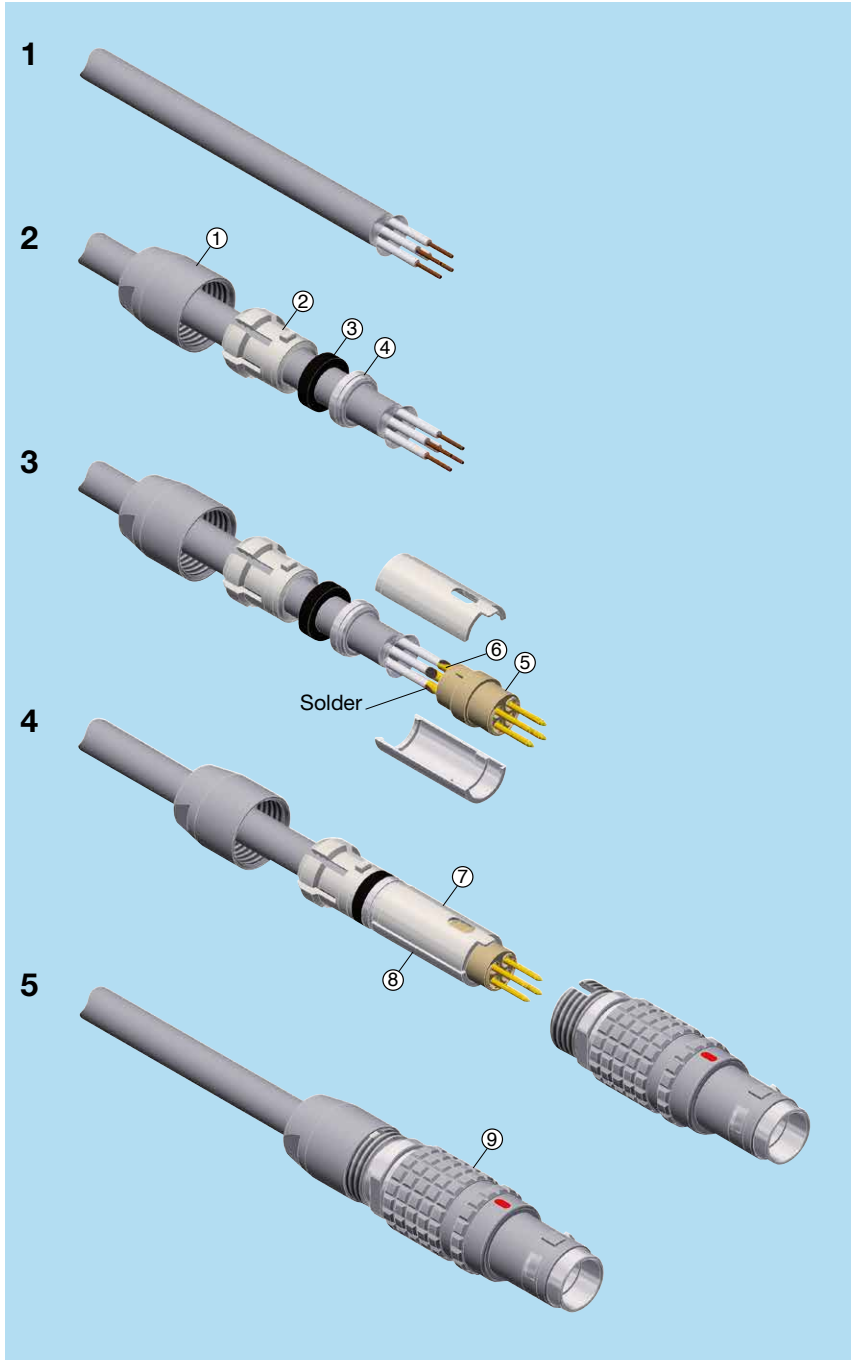

### Cable preparation

1. Strip the cable according to the given dimensions. (The end of the cable jacket must be cut properly).

### Cable termination

2. Slide it into the collet nut ①, the collet ②, the gland ③ and the earthing cone ④.
3. In case of a screened cable, fold screen back over the extremity of the earthing cone. Arrange the conductors according to the insulator ⑤ marking by avoiding to twist them. Fit conductor into the contacts ⑥ and solder. Verify that insulator and insulation remain clean.
4. Locate the slotted upper half ⑦ of the split insert carrier over the shoulder and key on the insulator then align and press together the other half ⑧ to form a complete cylinder. Push the earthing cone against the insert carriers whilst checking that the screen is being clamped around the whole circumference and cut, if necessary, the excess screen. Push the gland, and collet against the earthing cone. Push the cable forward and verify that cable jacket is located under the gland.
5. Next slide the plug shell ⑨ over the insulator assembly making sure that the key on the insert carrier goes into the keyway (under the color point) inside the shell. Locate the key of the collet into the slot of the shell. Finally screw the collet nut with the appropriate tool and tighten to the maximum torque value (see page 22).

## Product safety notice

**PLEASE READ AND FOLLOW ALL INSTRUCTIONS CAREFULLY AND CONSULT ALL RELEVANT NATIONAL AND INTERNATIONAL SAFETY REGULATIONS FOR YOUR APPLICATION. IMPROPER HANDLING, CABLE ASSEMBLY, OR WRONG USE OF CONNECTORS CAN RESULT IN HAZARDOUS SITUATIONS.**

### 1. SHOCK AND FIRE HAZARD

Incorrect wiring, the use of damaged components, presence of foreign objects (such as metal debris), and / or residue (such as cleaning fluids), can result in short circuits, overheating, and / or risk of electric shock. Mated components should never be disconnected while live as this may result in an exposed electric arc and local overheating, resulting in possible damage to components.

### 2. HANDLING

Connectors and their components should be visually inspected for damage prior to installation and assembly. Suspect components should be rejected or returned to the factory for verification. Connector assembly and installation should only be carried out by properly trained personnel. Proper tools must be used during installation and / or assembly in order to obtain safe and reliable performance.

### 3. USE

Connectors with exposed contacts should never be live (or on the current supply side of a circuit). Under general conditions voltages above 30 VAC and 42 VDC are considered hazardous and proper measures should be taken to eliminate all risk of transmission of such voltages to any exposed metal part of the connector.

### 4. TEST AND OPERATING VOLTAGES

The maximum admissible operating voltage depends upon the national or international standards in force for the application in question. Air and creepage distances impact the operating voltage; reference values are indicated in the catalog however these may be influenced by PC board design and / or wiring harnesses. The test voltage indicated in the catalog is 75% of the mean breakdown voltage; the test is applied at 500 V/s and the test duration is 1 minute.

### 5. CE MARKING

CE marking  means that the appliance or equipment bearing it complies with the protection requirements of one or several European safety directives.

CE marking  applies to complete products or equipment, **but not to electromechanical components, such as connectors.**

### 6. PRODUCT IMPROVEMENTS

The LEMO Group reserves the right to modify and improve to our products or specifications without providing prior notification.

### 7. **WARNING (Prop 65 State of California)**

Proposition 65 requires businesses to provide warnings to Californians about significant exposures to chemicals that cause cancer, birth defects or other reproductive harm. LEMO products are exempt from proposition 65 warnings because they are manufactured, marketed, and sold solely for commercial and industrial use. For further information, please visit <https://www.lemo.com/quality/LEMO-Prop-65-compliance-declaration.pdf>.

## Disclaimers

LEMO works constantly to improve the quality of its products; the information and illustrations figuring in this document may therefore vary and are not binding. In any case, LEMO makes no specific warranty of merchantability, fitness for a particular purpose, third party components as such or included in assembly, non-infringement, title, accuracy, completeness, or security. The user is fully responsible for his products and applications using LEMO component.

In no event shall LEMO, its affiliates, officers, agents or employees be liable for any incidental, indirect, special or consequential damages in connection with the products or services provided by LEMO, including (without limitation) loss of profits or revenues, interruption of business, loss of use of the products or any associated equipment, materials, components or products, damages to associated equipment or in combination with other components, materials.

Reproduction of significant portions of LEMO information in LEMO data books or data sheets is permissible only if reproduction is without alteration and is accompanied by all associated warranties, conditions, limitations, and notices. LEMO is not responsible or liable for such altered documentation. Information of third parties may be subject to additional restrictions.

## LEMO HEADQUARTERS

### SWITZERLAND

**LEMO SA**  
Chemin des Champs-Courbes 28 - P.O. Box 194 - CH-1024 Ecublens  
Tel. +41 21 695 16 00 - e-mail: info@lemo.com

## LEMO SUBSIDIARIES

### AUSTRIA

**LEMO Elektronik GesmbH**  
Lemböckgasse 49/E6-3  
1230 Wien  
Tel: +43 1 914 23 20 0  
Fax: +43 1 914 23 20 11  
salesAT@lemo.com

### BRAZIL

**LEMO Latin America Ltda**  
Av. Dr. Adhemar de Barros,  
566 – Sala 1407, Vila Adyana  
CEP: 12245-011  
São José dos Campos - SP - Brazil  
Tel: +55 11 94242 4293  
info-la@lemo.com

### CANADA

**LEMO Canada Inc**  
44 East Beaver Creek Road, unit 20  
Richmond Hill, Ontario L4B 1G8  
Tel: +1 905 889 56 78  
Fax: +1 905 889 49 70  
info-canada@lemo.com

### CHINA / HONG KONG

**LEMO Electronics (Shanghai) Co., Ltd**  
First Floor, Block E,  
18 Jindian Road, Pudong  
Shanghai, China, 201206  
Tel: +86 21 5899 7721  
Fax: +86 21 5899 7727  
cn.sales@lemo.com

### DENMARK

**LEMO Denmark A/S**  
Mandal Allé 16A  
5500 Middelfart  
Tel: +45 45 20 44 00  
Fax: +45 45 20 44 01  
info-dk@lemo.com

### FRANCE

**LEMO France Sàrl**  
24/28 Avenue Graham Bell  
Bâtiment Balthus 4  
Bussy Saint Georges  
77607 Marne la Vallée Cedex 3  
Tel: +33 1 60 94 60 94  
Fax: +33 1 60 94 60 90  
info-fr@lemo.com

### GERMANY

**LEMO Elektronik GmbH**  
Hanns-Schwindt-Str. 6  
81829 München  
Tel: +49 89 42 77 03  
Fax: +49 89 420 21 92  
info@lemo.de

### HUNGARY

**REDEL Elektronika Kft**  
Nagysándor József u. 6-12  
1201 Budapest  
Tel: +36 1 421 47 10  
Fax: +36 1 421 47 57  
info-hu@lemo.com

### ITALY

**LEMO Italia srl**  
Viale Lunigiana 25  
20125 Milano  
Tel: +39 02 66 71 10 46  
Fax: +39 02 37 90 80 46  
sales.it@lemo.com

### JAPAN

**LEMO Japan Ltd**  
2-7-22, Mita,  
Minato-ku, Tokyo, 108-0073  
Tel: +81 3 54 46 55 10  
Fax: +81 3 54 46 55 11  
info-jp@lemo.com

### NETHERLANDS / BELGIUM

**LEMO Connectors Nederland B.V.**  
Jacques Meuwissenweg 6  
2031 AD Haarlem  
Tel. +31 23 206 07 01  
info-nl@lemo.com

### NORWAY / ICELAND

**LEMO Norway A/S**  
Soerumsandvegen 69,  
1920 Soerumsand  
Tel: +47 22 91 70 40  
Fax: +47 22 91 70 41  
info-no@lemo.com

### SINGAPORE

**LEMO Asia Pte Ltd**  
4 Leng Kee Road,  
#06-09 SiS Building  
Singapore 159088  
Tel: +65 6476 0672  
Fax: +65 6474 0672  
sg.sales@lemo.com

### SPAIN / PORTUGAL

**IBERLEMO SAU**  
Brasil, 45, 08402 Granollers  
Barcelona  
Tel: +34 93 860 44 20  
Fax: +34 93 879 10 77  
info-es@lemo.com

### SWEDEN / FINLAND

**LEMO Nordic AB**  
Gunnébogatan 30, Box 8201  
163 08 Spånga  
Tel: +46 8 635 60 60  
Fax: +46 8 635 60 61  
info-se@lemo.com

### SWITZERLAND

**LEMO Verkauf AG**  
Grundstrasse 22 B,  
6343 Rotkreuz  
Tel: +41 41 790 49 40  
ch.sales@lemo.com

### TAIWAN

**TAOYUAN TAIWAN**  
Tel: +886 967 132 824  
speng@lemo.com

### UNITED ARAB EMIRATES

**LEMO Middle East Connectors LLC**  
Concorde Tower 11th Floor,  
Office 1102, Dubai Media City,  
P.O. Box 449849  
Dubai, United Arab Emirates  
Tel: +971 4 568 1904  
info-me@lemo.com

### UNITED KINGDOM

**LEMO UK Ltd**  
12-20 North Street, Worthing,  
West Sussex, BN11 1DU  
Tel: +44 1903 23 45 43  
lemouk@lemo.com

### USA

**LEMO USA Inc**  
P.O. Box 2408  
Rohnert Park, CA 94927-2408  
Tel: +1 707 578 88 11  
+1 800 444 53 66  
Fax: +1 707 578 08 69  
info-US@lemo.com

## LEMO DISTRIBUTORS

ARGENTINA, AUSTRALIA, BRAZIL, CHILE, COLOMBIA, CZECH REPUBLIC,  
GREECE, INDIA, ISRAEL, NEW ZEALAND, PERU, POLAND, RUSSIA,  
SOUTH AFRICA, SOUTH KOREA, TURKEY, UKRAINE

www.lemo.com

CAT-MT-LEN-P0115, © LEMO / Data subject to change, printed in Switzerland, updated September 2021

U.S. Air Force photo/Tech. Sgt. Shane A.

