

# LT3652HVEDD 17.7V to 34V Input SLA 2A Battery Charger For Solar Power

## DESCRIPTION

Demonstration circuit 1688A is a sealed-lead acid 2A battery charger for solar power applications featuring the LT3652HVEDD. The LT3652HV is a complete mid-power battery charger that can operate over a wide input voltage range. The charger employs a 3.3V battery voltage feedback reference that allows the voltage for charging to be adjusted up to 18V. The LT3652HV has an input voltage regulation loop which reduces charge current if the input falls below a programmed level, set with a resistor divider. The circuit provides constant-current/constant-voltage charging with a maximum charge current of 2A that is

programmed by a current sense resistor. A precondition feature trickle charges a low voltage battery, and bad battery detection provides a signal if the battery doesn't respond to preconditioning.

The LT3652HVEDD is available in a 12-lead (3mm × 3mm) DFN surface mount package with an exposed pad.

**Design files for this circuit board are available at <http://www.linear.com/demo>**

LT, LT, LTC, LTM, Linear Technology and the Linear logo are registered trademarks of Linear Technology Corporation. All other trademarks are the property of their respective owners.

## PERFORMANCE SUMMARY

**Table 1. Typical Specifications (T<sub>A</sub> = 25°C)**

PARAMETER	CONDITIONS	VALUE
Input Voltage Range		17.7V to 34V
V <sub>BAT</sub> Charge/V <sub>BAT</sub> Float		14.3V to 14.5V/13.4V to 13.6V
Output Charge/Float Voltage	Constant Voltage Mode	14.4V/13.5V
Output Current Limit I <sub>LIM</sub>	V <sub>IN_REG</sub> Greater Than 2.7V	2A

## OPERATING PRINCIPLE

LT3652HV is a complete monolithic mid-power battery charger, addressing high input voltage applications with solutions that require a minimum number of external components. The IC uses a 1MHz constant frequency, average current mode step-down architecture.

The LT3652HV maximizes efficiency during charging cycles by using a bootstrapped supply to drive the internal power switch. Figures 1 and 2 display charger efficiency and input current for various input voltages and battery voltages. A precision threshold shutdown pin allows the incorporation of UVLO functionality using a simple resistor divider. The IC can also be put into a low-current shutdown mode, in which the input supply bias is reduced to only 15µA.

The LT3652HV incorporates several degrees of charge current control freedom. The overall maximum charge current is set using an external inductor current sense resistor. The LT3652HV employs an input voltage regulation loop which reduces charge current if the input voltage falls below a programmed level, set with a voltage divider. This can be seen in Figure 3. When the LT3652HV is powered by a solar panel, the input regulation loop is used to maintain the panel at peak output power.

The LT3652HV automatically enters a battery precondition mode if the sensed battery voltage is very low. In this mode, the charging current is reduced to 15% of the programmed maximum, as set by the inductor sense

## OPERATING PRINCIPLE

resistor,  $R_{SENSE}$ . Once the battery voltage increases to the precondition threshold, the IC automatically increases maximum charging current to the full programmed value. DC1688A programs the output voltage to be 14.4V during charging and the 9.5V precondition threshold is internally set as a fraction of the programmed output voltage.

The LT3652HV can use a charge current based 'C/10' termination scheme, which ends a charge cycle when the battery charge current falls to 1/10th the programmed maximum charge current. The LT3652HV also contains an internal charge cycle control timer, for timer-based termination. When using the internal timer, the IC combines C/10 detection with a programmable time constraint, during which the charging cycle can continue beyond the C/10 level. DC1688A programs a lower 13.5V float output voltage at the time the C/10 condition occurs. Use of the internal timer allows DC1688A to provide a float voltage to the battery until the charge cycle terminates because time elapses. The timer on DC1688A is programmed so the circuit can provide a float voltage all day, as may be needed by a solar panel application. When the timer-based scheme is used, the IC also supports "bad battery" detection, which

triggers a system fault if a battery stays in precondition mode for more than 1/8th of the total charge cycle time.

Once charging is terminated and the LT3652HV is not actively charging, the IC automatically enters a low current standby mode where supply bias currents are reduced to  $< 100\mu A$ . If the battery voltage drops 2.5% from the full-charge float voltage, the LT3652HV engages an automatic charge cycle restart. The IC also automatically restarts a new charge cycle after a bad battery fault once the failed battery is removed and replaced with another battery.

The LT3652HV includes provisions for a battery temperature monitoring circuit. This feature monitors battery temperature during the charging cycle using a thermistor, and suspends charging and signals a fault condition if the battery temperature moves outside a safe charging range of  $0^{\circ}C$  to  $50^{\circ}C$ .

The LT3652HV contains two digital open-collector outputs, which provide charger status and signal fault conditions. These binary-coded pins signal battery charging, standby or shutdown modes, battery temperature faults, and bad battery faults.

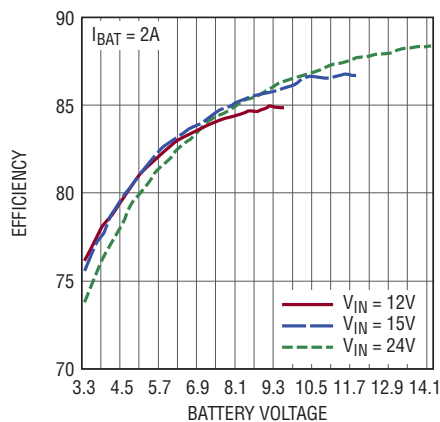

Figure 1. LT3652HV Efficiency

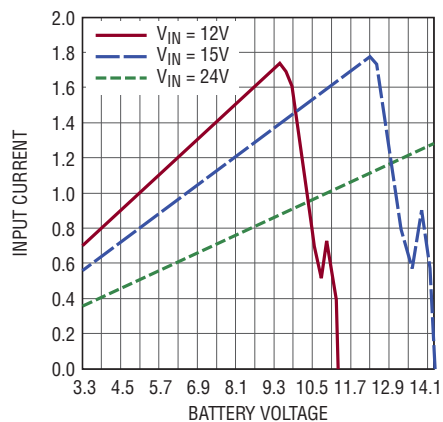

Figure 2. 2A Charge Current

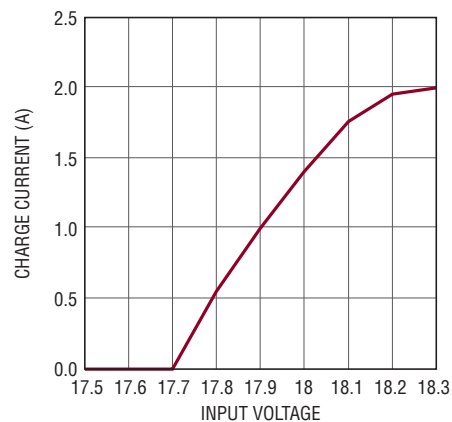

Figure 3. Charge Current vs Input Voltage

## QUICK START PROCEDURE

Demonstration circuit 1688A is easy to set up to evaluate the performance of the LT3652HV EDD.

Using short twisted pair leads for any power connections, with all loads and power supplies off, refer to Figure 4 for the proper measurement and equipment setup.

## QUICK START PROCEDURE

Follow the procedure below:

### 1. Jumper and Power Supply Setting:

JP1 = 1                      JP4 = 1  
 JP2 = 0                      PS1 = OFF  
 JP3 = C/10                  PS2 = OFF

2. Turn on PS2 and slowly increase the voltage until  $V_{BAT}$  is 7.5V while monitoring the current into the BAT pin. If the current is less than 5mA, turn on PS1. Increase PS1 until  $V_{IN}$  is 18V while monitoring the input current.
3. Verify the battery charging current is between 250mA and 350mA. The CHRG LED should be on and the FAULT LED should be off.
4. Increase PS2 until  $V_{BAT}$  is 12.0V. Verify the input current is between 1.3A and 1.7A, the battery current is between 1.775A and 2.225A and that the CHRG LED is on.
5. Increase PS2 until  $V_{BAT}$  is 14.8V. Verify the battery charging current is less than 5mA and that the CHRG LED is off.
6. Decrease PS2 until  $V_{BAT}$  is 13.8V. Verify the battery charging current is less than 5mA and that the CHRG LED is off.
7. Decrease PS2 until  $V_{BAT}$  is 12.0V. Verify the battery current is between 1.775A and 2.225A and that the CHRG LED is on.

8. Set JP1 to 0. Verify the charging current is less than 5mA and that the FAULT LED and the CHRG LED are off.
9. Set JP1 to 1. Connect a jumper from the NTC pin to ground. Verify the charging current is less than 5mA and that the FAULT LED and the CHRG LED are on.
10. Remove the jumper from NTC to ground. Verify the charging current is between 1.775A and 2.225A and that the FAULT LED is off and the CHRG LED is on.
11. Turn on LOAD1 and set to 1A. Verify the voltage,  $V_{system}$ , on the System Load terminal is approximately equal to  $V_{IN}$ . Turn off LOAD1. Decrease PS1 to 14.0V.
12. Verify the battery charging current is less than 5mA and that the CHRG LED is off.
13. Increase PS1 to 18.5V. Verify the charging current is between 1.775A and 2.225A and that the CHRG LED is on. Set JP2 to 1. Decrease PS1 to 17.0V.
14. Set JP4 to 0. Setting JP4 to 0 turns off the charge current when  $V_{IN}$  is less than 17.7V. Verify the battery charging current is less than 5mA and that the CHRG LED is off.
15. Increase PS1 to 19.0V. Verify the charging current is between 1.775A and 2.225A and that the CHRG LED is on. Set JP4 to 1. Set JP2 to 0.
16. Turn off PS1 and PS2.

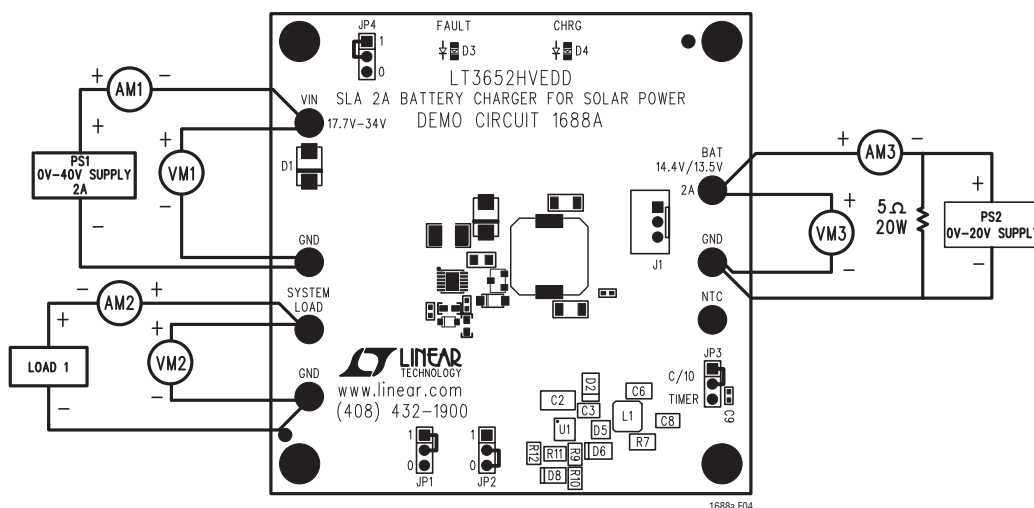

Note: All Connections from Equipment Should Be Kelvin Connected Directly to the Board Pins Which They Are Connected to on This Diagram and Any Input, or Output, Leads Should Be Twisted Pair.

Figure 4. Proper Measurement Equipment Setup for DC1688A

# DEMO MANUAL DC1688A

## PARTS LIST

ITEM	QTY	REFERENCE-DESCRIPTION	DESCRIPTION	MANUFACTURER'S PART NUMBER
<b>Required Circuit Components:</b>				
1	1	C2	CAP., X7R, 10 $\mu$ F, 50V, 10%, 1210	MURATA, GRM32ER71H106KA88L
2	1	C3	CAP., X7R, 1 $\mu$ F, 50V, 10%, 0805	MURATA, GRM21BR71H105KA12B
3	1	C5	CAP., SMT, 100 $\mu$ F, 20V, 20%	SANYO, 20SVP100M
4	1	C6	CAP., X7R, 10 $\mu$ F, 25V, 10%, 1206	MURATA, GRM31CR71E106KA12L
5	1	C9	CAP., X5R, 4.7 $\mu$ F, 4V, 20%, 0402	MURATA, GRM155R60G475M
6	2	D1, D2	SMD, SCHOTTKY BARRIER RECTIFIER	CENTRAL SEMI, CMSH3-40MA
7	1	D5	SMD, SCHOTTKY DIODE, SOT-23F	CENTRAL SEMI, CMPSH1-4
8	1	D6	SMD, ZENER DIODE, 6.2V, SOT-23	CENTRAL SEMI, CMHZ4691TR
9	1	D8	SMD, SWITCHING DIODE, SOD323	VISHAY, 1N4148WS-V-GS08
10	1	L1	POWER INDUCTOR, 15 $\mu$ H, 20%, 3.5A	COILCRAFT, MSS1038-153ML
11	1	R1	RES., CHIP, 1.33MEG, 1/16W, 1%, 0402	VISHAY, CRCW04021M33FKED
12	1	R4	RES., CHIP, 562K, 1/16W, 1%, 0402	VISHAY, CRCW0402562KFKED
13	2	R5, R6	RES., CHIP, 100K, 1/16W, 1%, 0402	VISHAY, CRCW0402100KFKED
14	1	R7	RES., CHIP, 0.05 OHM, 1/2W, 1%, 1206	SUSUMU, RL1632R-R050-F
15	1	R9	RES., CHIP, 174K, 1/16W, 1%, 0402	VISHAY, CRCW0402174KFKED
16	1	R10	RES., CHIP, 309K, 1/16W, 0.1%, 0603	SUSUMU, RG1608P-3093-B-T5
17	1	R11	RES., CHIP, 100K, 1/16W, 0.1%, 0603	SUSUMU, RG1608P-104-B-T5
18	1	R12	RES., CHIP, 1.00MEG, 1/16W, 1%, 0402	VISHAY, CRCW04021M00FKED
19	1	U1	SLA 2A BATTERY CHARGER FOR SOLAR POWER	LINEAR TECHNOLOGY, LT3652HVEDD
<b>Additional Demo Board Circuit Components:</b>				
1	1	C1	CAP., SMT, 390 $\mu$ F, 50V, 20	SANYO, 50CE390BS
2	2	C7, C8	CAP., CHIP, X7R, 0.022 $\mu$ F, $\pm$ 10%, 16V, 0402	AVX, 0402YC223KAT2A
3	1	D3	LED, RED	PANASONIC, LN208R8ARA
4	1	D4	LED, GREEN	LITE-ON, LTST-C190KGKT
5	2	R2, R3	RES., CHIP, 5.1K, 1/4W, 1%, 1206	VISHAY, CRCW12065K10FKEA
6	1	R8	RES., CHIP, 20, 1/16W, 5%, 0402	VISHAY, CRCW040220R0JNED
<b>Optional Demo Board Circuit Components:</b>				
1	0	C4(OPT)	CAP., OPT, 0402	CUSTOMER SELECTABLE
2	0	D7(OPT)	SMD, SCHOTTKY BARRIER RECTIFIER	CENTRAL SEMI, CMSH3-40MA
3	0	D9(OPT)	SMD, ZENER DIODE, 10V, SOT-23	CENTRAL SEMI, CMHZ4697
4	0	J1(OPT)	HEADER, 3 PINS	HIROSE ELECTRIC, DF3A-3P-2DSA
5	0	R13(OPT)	RES., CHIP, 10K, 1/16W, 1%, 0402	VISHAY, CRCW040210K0FKED
6	0	R14(OPT)	RES., CHIP, 100K, 1/16W, 1%, 0402	VISHAY, CRCW0402100KFKED
7	0	Q1(OPT)	SMD, P-CHANNEL MOSFET, 40V, 82m $\Omega$	VISHAY, SI2319DS
<b>Hardware For Demo Board Only:</b>				
1	7	E1-E7	TESTPOINT, TURRET, .095"	MILL-MAX, 2501-2-00-80-00-00-07-0
2	1	J1	HEADER, 3 PINS	HIROSE ELECTRIC, DF3A-3P-2DSA
3	4	JP1-JP4	2mm SINGLE ROW HEADER, 3 PIN	SAMTEC, TMM-103-02-L-S
4	4	JP1-JP4	SHUNT	SAMTEC, 2SN-BK-G
5	4		STAND-OFF, NYLON, 0.625" TALL (SNAP ON)	KEYSTONE, 8834 (SNAP ON)

**SCHEMATIC DIAGRAM**

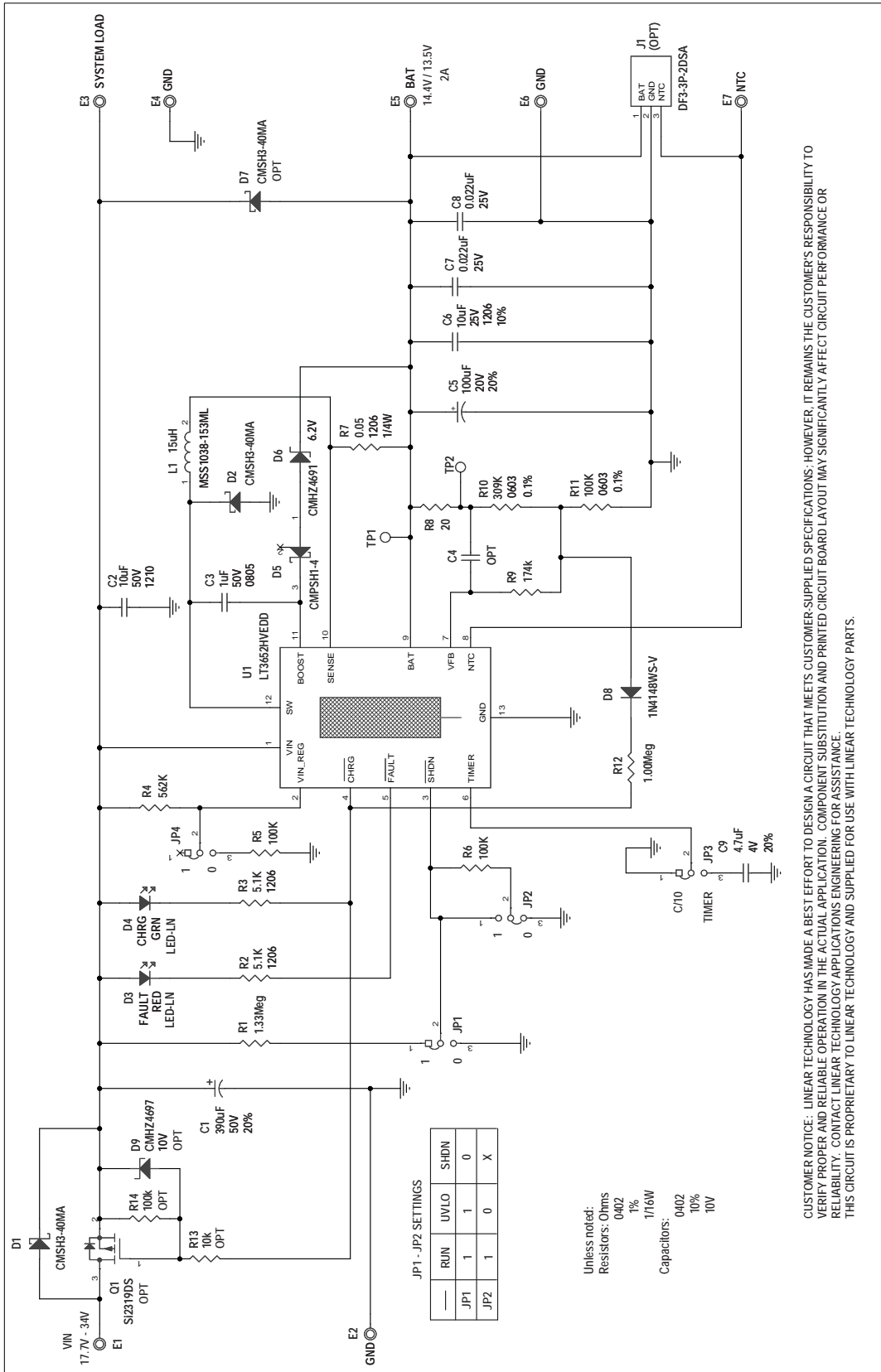

CUSTOMER NOTICE: LINEAR TECHNOLOGY HAS MADE A BEST EFFORT TO DESIGN A CIRCUIT THAT MEETS CUSTOMER-SUPPLIED SPECIFICATIONS; HOWEVER, IT REMAINS THE CUSTOMER'S RESPONSIBILITY TO VERIFY PROPER AND RELIABLE OPERATION IN THE ACTUAL APPLICATION. COMPONENT SUBSTITUTION AND PRINTED CIRCUIT BOARD LAYOUT MAY SIGNIFICANTLY AFFECT CIRCUIT PERFORMANCE OR RELIABILITY. CONTACT LINEAR TECHNOLOGY APPLICATIONS ENGINEERING FOR ASSISTANCE. THIS CIRCUIT IS PROPRIETARY TO LINEAR TECHNOLOGY AND SUPPLIED FOR USE WITH LINEAR TECHNOLOGY PARTS.

# DEMO MANUAL DC1688A

---

## DEMONSTRATION BOARD IMPORTANT NOTICE

Linear Technology Corporation (LTC) provides the enclosed product(s) under the following **AS IS** conditions:

This demonstration board (DEMO BOARD) kit being sold or provided by Linear Technology is intended for use for **ENGINEERING DEVELOPMENT OR EVALUATION PURPOSES ONLY** and is not provided by LTC for commercial use. As such, the DEMO BOARD herein may not be complete in terms of required design-, marketing-, and/or manufacturing-related protective considerations, including but not limited to product safety measures typically found in finished commercial goods. As a prototype, this product does not fall within the scope of the European Union directive on electromagnetic compatibility and therefore may or may not meet the technical requirements of the directive, or other regulations.

If this evaluation kit does not meet the specifications recited in the DEMO BOARD manual the kit may be returned within 30 days from the date of delivery for a full refund. **THE FOREGOING WARRANTY IS THE EXCLUSIVE WARRANTY MADE BY THE SELLER TO BUYER AND IS IN LIEU OF ALL OTHER WARRANTIES, EXPRESSED, IMPLIED, OR STATUTORY, INCLUDING ANY WARRANTY OF MERCHANTABILITY OR FITNESS FOR ANY PARTICULAR PURPOSE. EXCEPT TO THE EXTENT OF THIS INDEMNITY, NEITHER PARTY SHALL BE LIABLE TO THE OTHER FOR ANY INDIRECT, SPECIAL, INCIDENTAL, OR CONSEQUENTIAL DAMAGES.**

The user assumes all responsibility and liability for proper and safe handling of the goods. Further, the user releases LTC from all claims arising from the handling or use of the goods. Due to the open construction of the product, it is the user's responsibility to take any and all appropriate precautions with regard to electrostatic discharge. Also be aware that the products herein may not be regulatory compliant or agency certified (FCC, UL, CE, etc.).

No License is granted under any patent right or other intellectual property whatsoever. **LTC assumes no liability for applications assistance, customer product design, software performance, or infringement of patents or any other intellectual property rights of any kind.**

LTC currently services a variety of customers for products around the world, and therefore this transaction **is not exclusive**.

**Please read the DEMO BOARD manual prior to handling the product.** Persons handling this product must have electronics training and observe good laboratory practice standards. **Common sense is encouraged.**

This notice contains important safety information about temperatures and voltages. For further safety concerns, please contact a LTC application engineer.

Mailing Address:

Linear Technology  
1630 McCarthy Blvd.  
Milpitas, CA 95035

Copyright © 2004, Linear Technology Corporation