

Evaluation kit for the LED1202 12-channel low quiescent current LED driver

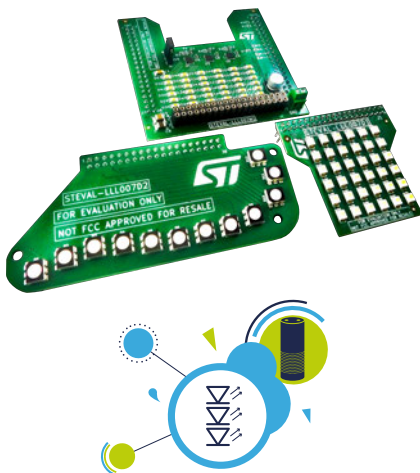

Features

- 3x LED1202 12-channel low quiescent current LED drivers embedded on main board
- Can immediately drive 36 white LEDs available on main board, to help you get started
- Includes additional panel boards to let you expand your development:
 - 1 with 36 white LEDs
 - 1 with 12 RGB LEDs
- Designed for use with NUCLEO-L073RZ development platform running the STSW-LLL007FW firmware.
- E5V connector to supply STM32 Nucleo board and additional panels
- Supplied with a range of default patterns
- GUI for advanced driver configuration and customized pattern generation
- CE Certified
- RoHS and China RoHS compliant
- WEEE compliant (2012/19/UE RAEE II)

Description

The STEVAL-LLL007V1 kit consists of the STEVAL-LLL007M1 main board and the STEVAL-LLL007D1 and STEVAL-LLL007D2 panel boards.

To help you evaluate all the features of the [LED1202](#) driver, you can connect the main board to a NUCLEO-L073RZ development platform running the STSW-LLL007FW firmware, which comes with pre-configured random and wave patterns for use in standalone mode.

You can even develop your own pattern sequences by connecting the Nucleo platform to a PC running a dedicated GUI program, which also gives you access to all the LED driver settings.

To achieve the maximum luminosity, you need to supply the STEVAL-LLL007D1 panel board and the STEVAL-LLL007D2 panel board with an external power source via the J13 connector on the STEVAL-LLL007M1 board.

| Product summary | |
|--|--|
| 12-channel low quiescent current LED driver | LED1202 |
| Main board with LED1202 driver and 36 white LEDs | STEVAL-LLL007M1 (not available separately) |
| Panel board with 36 white LEDs | STEVAL-LLL007D1 (not available separately) |
| Panel board with 12 RGB LEDs | STEVAL-LLL007D2 (not available separately) |

1 Block diagrams

Figure 1. STEVAL-LLL007V1 block diagram

Kit consists of:

- STEVAL-LLL007M1 main board
- STEVAL-LLL007D1 panel board with 36 white LEDs
- STEVAL-LLL007D2 panel board with 12 RGB LEDs

The STEVAL-LLL007V1 can be connected to an STM32 Nucleo board for programming and debugging purposes

You can connect your own custom LED board through the same connector used to connect the panel boards with the main board

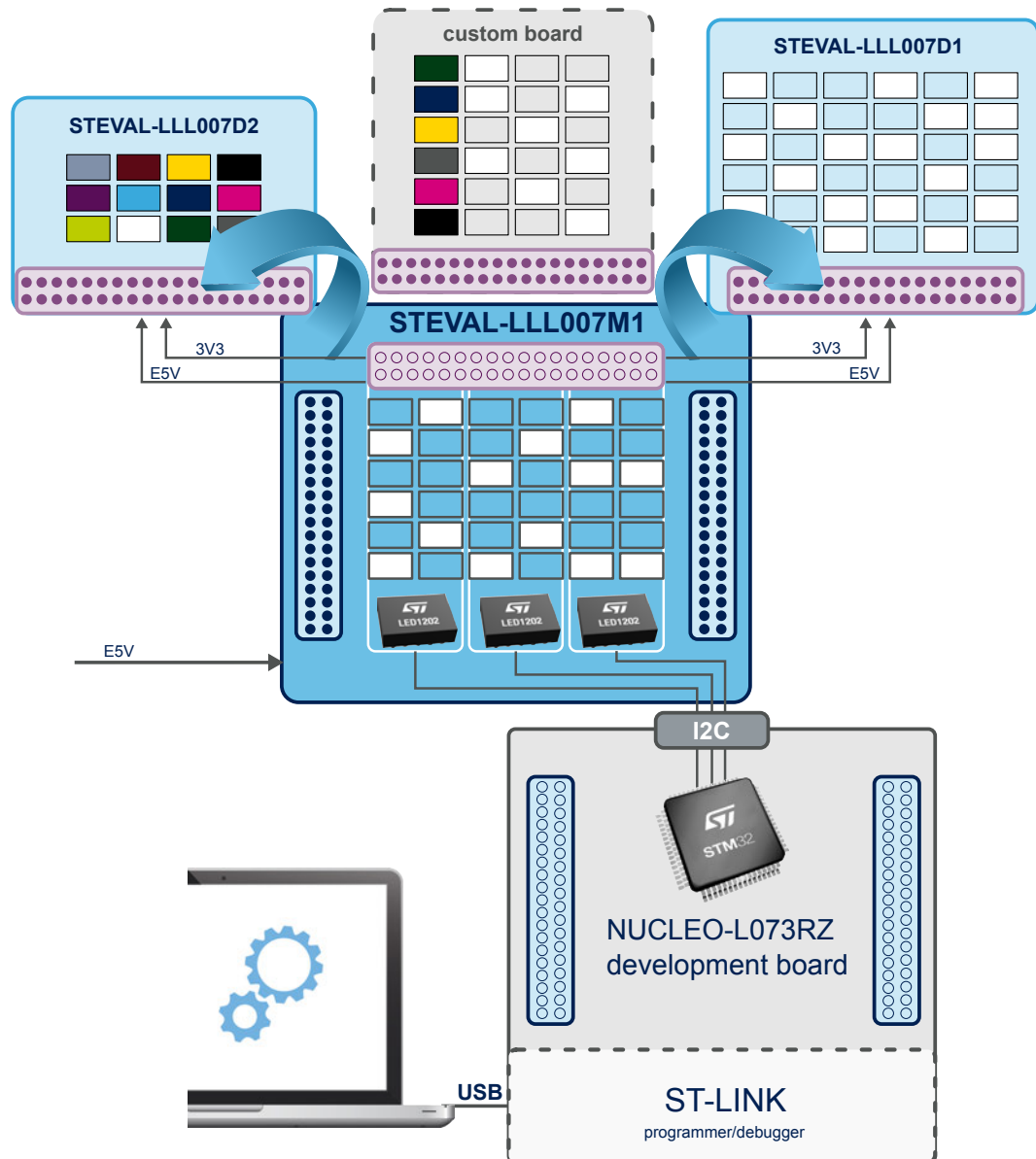

2 Schematic diagrams

Figure 2. STEVAL-LLL007M1 circuit schematic

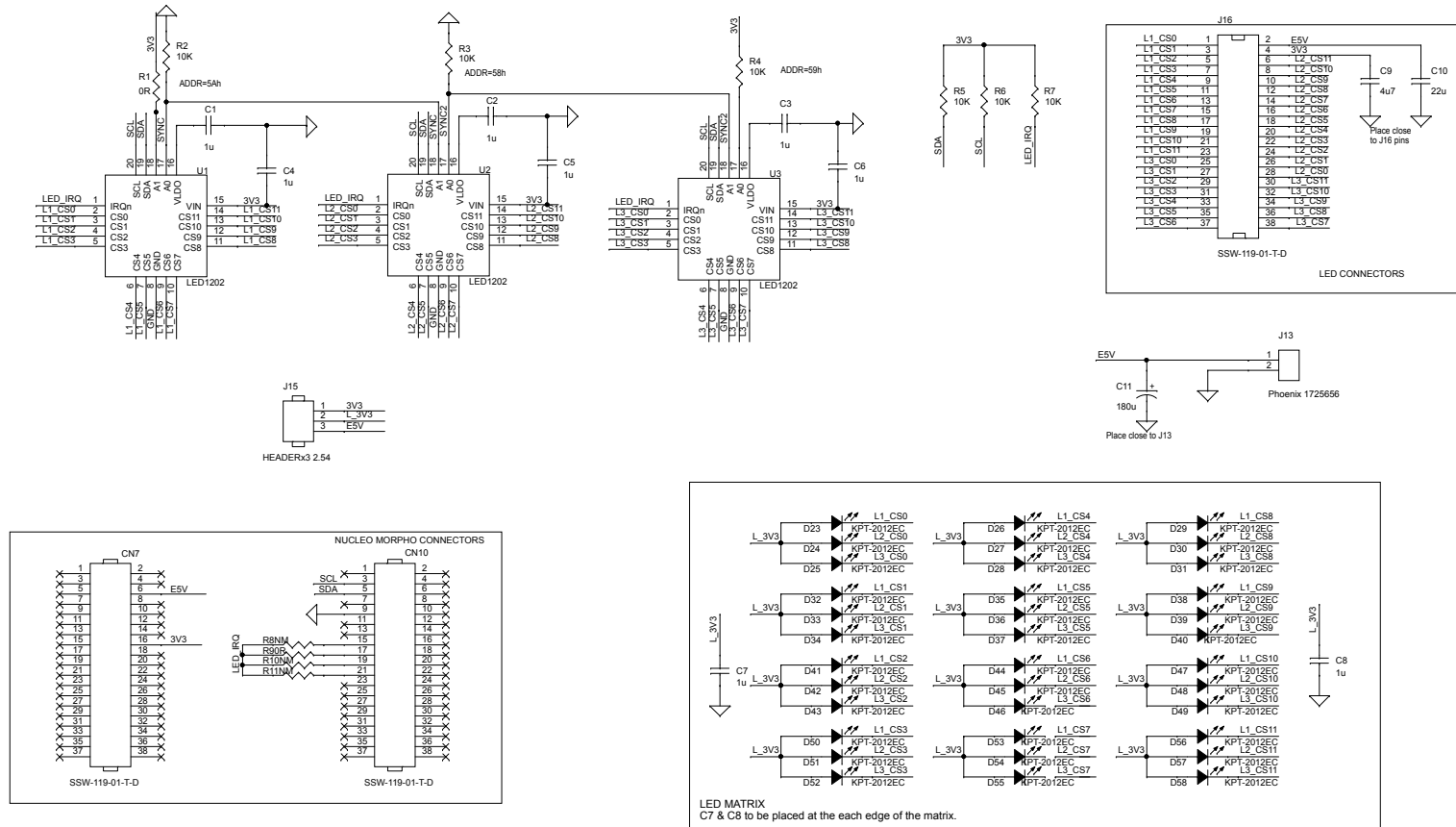
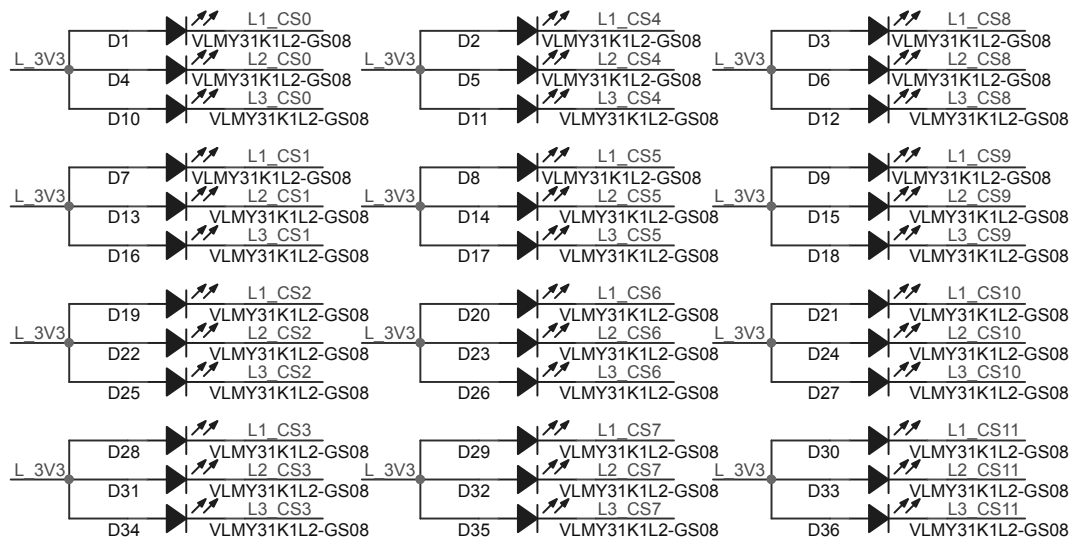

Figure 3. STEVAL-LLL007D1 circuit schematic



J1

| | | | |
|---------|----|----|-----------|
| L1_CS0 | 1 | 2 | L_3V3 |
| L1_CS1 | 3 | 4 | |
| L1_CS2 | 5 | 6 | × L3_CS11 |
| L1_CS3 | 7 | 8 | L3_CS10 |
| L1_CS4 | 9 | 10 | L3_CS9 |
| L1_CS5 | 11 | 12 | L3_CS8 |
| L1_CS6 | 13 | 14 | L3_CS7 |
| L1_CS7 | 15 | 16 | L3_CS6 |
| L1_CS8 | 17 | 18 | L3_CS5 |
| L1_CS9 | 19 | 20 | L3_CS4 |
| L1_CS10 | 21 | 22 | L3_CS3 |
| L1_CS11 | 23 | 24 | L3_CS2 |
| L2_CS0 | 25 | 26 | L3_CS1 |
| L2_CS1 | 27 | 28 | L3_CS0 |
| L2_CS2 | 29 | 30 | L2_CS11 |
| L2_CS3 | 31 | 32 | L2_CS10 |
| L2_CS4 | 33 | 34 | L2_CS9 |
| L2_CS5 | 35 | 36 | L2_CS8 |
| L2_CS6 | 37 | 38 | L2_CS7 |

header 2 rows - pitch 2.54



Figure 4. STEVAL-LLL007D2 circuit schematic

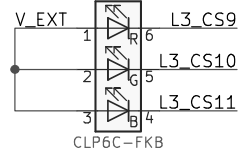
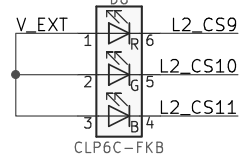
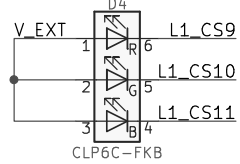
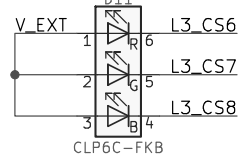
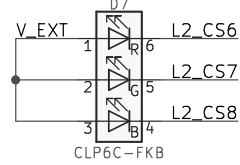
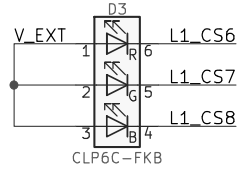
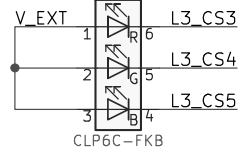
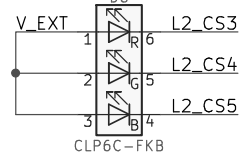
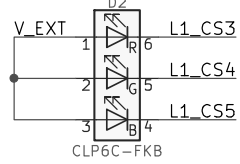
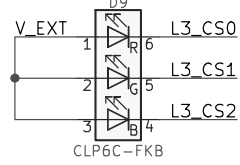
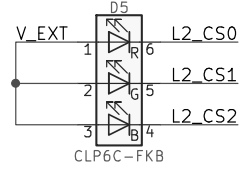
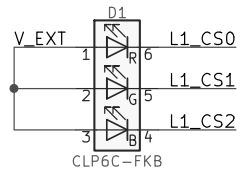

| | | | | |
|---------|----|----|----|---------|
| L1_CS0 | 1 | J1 | 2 | V_EXT |
| L1_CS1 | 3 | J1 | 4 | |
| L1_CS2 | 5 | J1 | 6 | L3_CS11 |
| L1_CS3 | 7 | J1 | 8 | L3_CS10 |
| L1_CS4 | 9 | J1 | 10 | L3_CS9 |
| L1_CS5 | 11 | J1 | 12 | L3_CS8 |
| L1_CS6 | 13 | J1 | 14 | L3_CS7 |
| L1_CS7 | 15 | J1 | 16 | L3_CS6 |
| L1_CS8 | 17 | J1 | 18 | L3_CS5 |
| L1_CS9 | 19 | J1 | 20 | L3_CS4 |
| L1_CS10 | 21 | J1 | 22 | L3_CS3 |
| L1_CS11 | 23 | J1 | 24 | L3_CS2 |
| L2_CS0 | 25 | J1 | 26 | L3_CS1 |
| L2_CS1 | 27 | J1 | 28 | L3_CS0 |
| L2_CS2 | 29 | J1 | 30 | L2_CS11 |
| L2_CS3 | 31 | J1 | 32 | L2_CS10 |
| L2_CS4 | 33 | J1 | 34 | L2_CS9 |
| L2_CS5 | 35 | J1 | 36 | L2_CS8 |
| L2_CS6 | 37 | J1 | 38 | L2_CS7 |

TSW-119-14-T-D



Revision history

Table 1. Document revision history

| Date | Version | Changes |
|-------------|---------|------------------|
| 07-Mar-2019 | 1 | Initial release. |

IMPORTANT NOTICE – PLEASE READ CAREFULLY

STMicroelectronics NV and its subsidiaries (“ST”) reserve the right to make changes, corrections, enhancements, modifications, and improvements to ST products and/or to this document at any time without notice. Purchasers should obtain the latest relevant information on ST products before placing orders. ST products are sold pursuant to ST’s terms and conditions of sale in place at the time of order acknowledgement.

Purchasers are solely responsible for the choice, selection, and use of ST products and ST assumes no liability for application assistance or the design of Purchasers’ products.

No license, express or implied, to any intellectual property right is granted by ST herein.

Resale of ST products with provisions different from the information set forth herein shall void any warranty granted by ST for such product.

ST and the ST logo are trademarks of ST. All other product or service names are the property of their respective owners.

Information in this document supersedes and replaces information previously supplied in any prior versions of this document.

© 2019 STMicroelectronics – All rights reserved

Mouser Electronics

Authorized Distributor

Click to View Pricing, Inventory, Delivery & Lifecycle Information:

[STMicroelectronics:](#)

[STEVAL-LLL007V1](#)