

Check-choke valve, Series CC04

- $Q_n 2 \rightarrow 1 = 470 \text{ l/min}$
- direction of throttle $2 \rightarrow 1$
- exhaust air throttling
- push-in fitting / External thread



Working pressure min./max.	0,5 ... 10 bar
Ambient temperature min./max.	-10 ... 60 °C
Medium temperature min./max.	-10 ... 60 °C
Medium	Compressed air

Technical data

Part No.	Port 1	Port 2	Throttle bore	Flow	Fig.
			Ø	$Q_n 2 \rightarrow 1$	
R412010564	Ø 4	M5	2 mm	70 l/min	Fig. 1
R412010565	Ø 6	M5	2 mm	110 l/min	Fig. 1
R412010568	Ø 4	G 1/8	3,5 mm	150 l/min	Fig. 2
R412010569	Ø 6	G 1/8	3,5 mm	390 l/min	Fig. 2
R412010570	Ø 8	G 1/8	3,5 mm	470 l/min	Fig. 2

Technical information

Material	
Housing	Polyamide
Seals	Acrylonitrile butadiene rubber
Port	Brass, nickel-plated

Dimensions

Dimensions

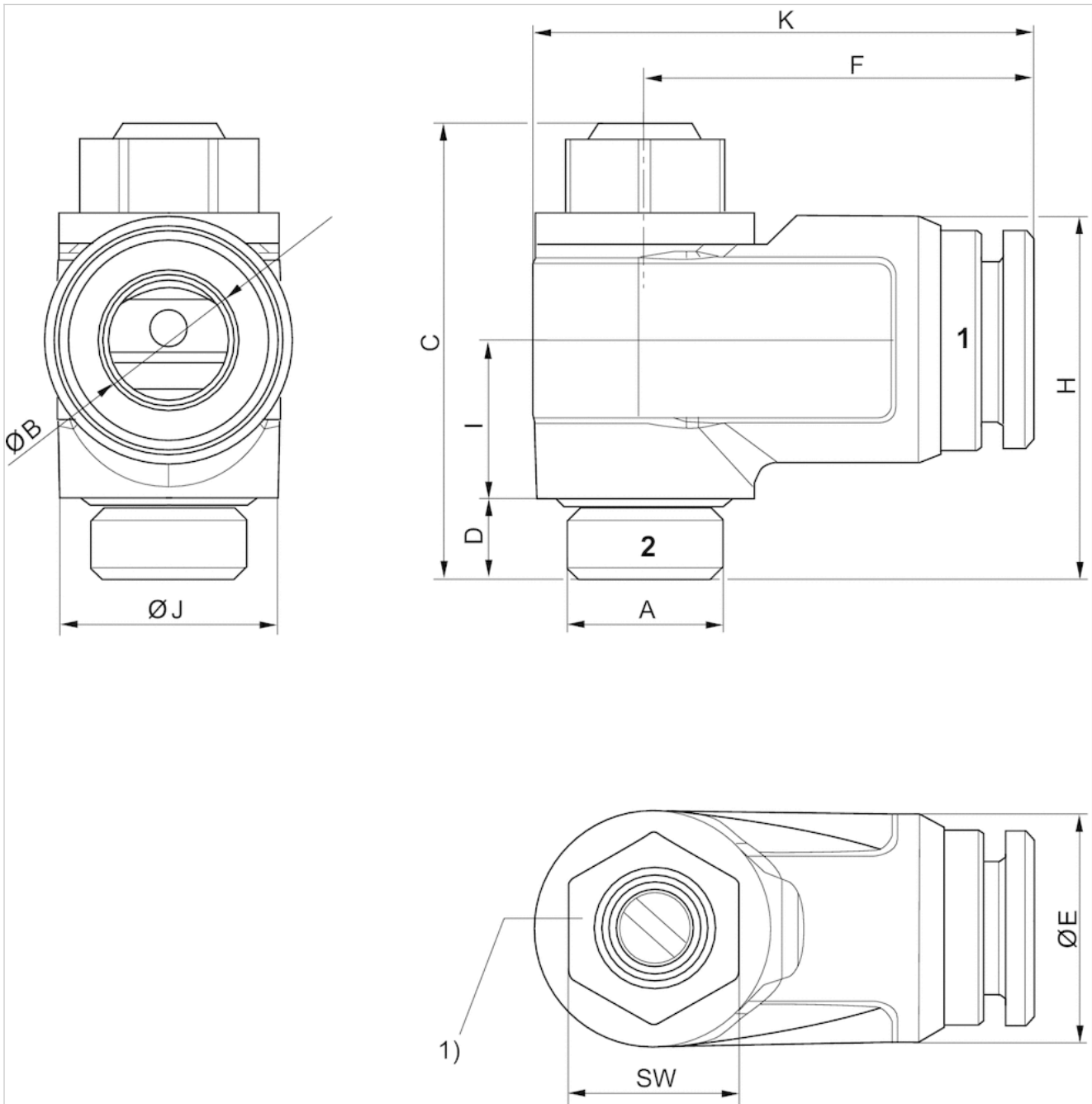

1) Recommended tightening torque MA:

- M 5: 1.1 Nm -0.2
- G 1/8: 3.0 Nm -0.3
- G 1/4: 6.0 Nm -0.6
- G 3/8: 8.0 Nm -1.0
- G 1/2: 10.0 Nm -1.0

Dimensions

Part No.	Port 1	Port 2	Ø B	C	D	Ø E	F	K	H	I	Ø J	SW
R412010564	Ø 4	M5	4	21.8	4	9	15.9	20.4	12	7.5	8.7	7
R412010565	Ø 6	M5	6	21.8	4	11.1	17.2	21.8	13	7.5	8.7	7

Part No.	Port 1	Port 2	Ø B	C	D	Ø E	F	K	H	I	Ø J	SW
R412010568	Ø 4	G 1/8	4	28.5	5.5	11.5	21.9	28.8	21	9.8	13.6	10
R412010569	Ø 6	G 1/8	6	28.5	5.5	13.5	22.4	29.3	21.7	9.8	13.6	10
R412010570	Ø 8	G 1/8	8	28.5	5.5	15.5	24.2	31.1	22.7	9.8	13.6	10

Diagrams

Flow diagram, Fig. 1

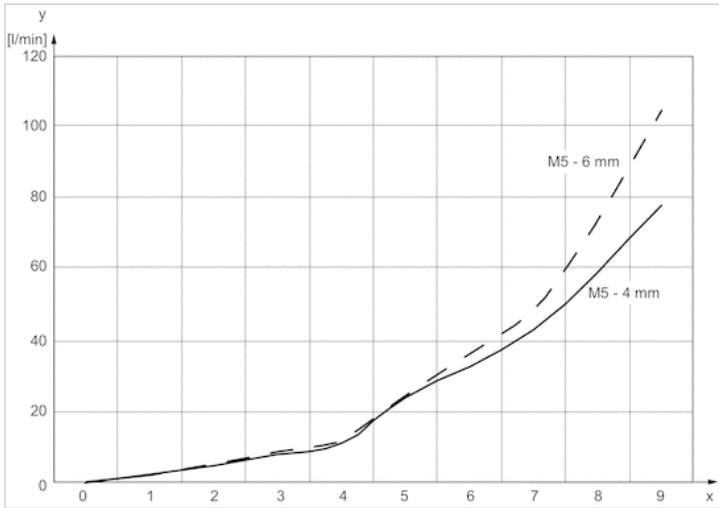

x = rotations of the throttle screw
y = flow rate Qn

Flow diagram, Fig. 2

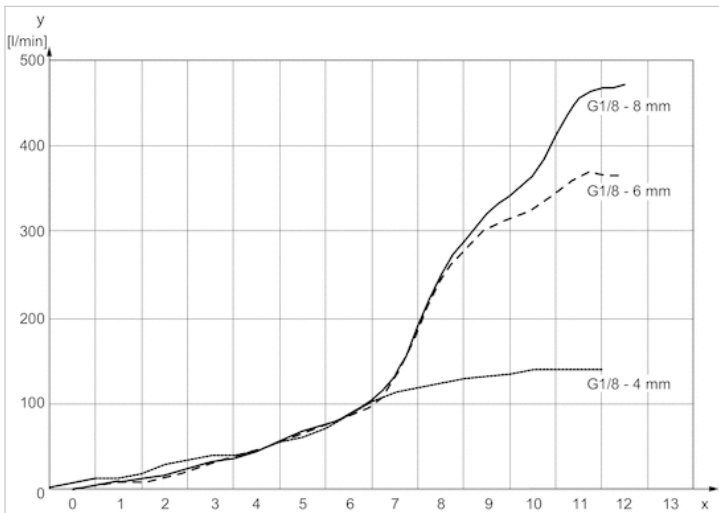

x = rotations of the throttle screw
y = flow rate Qn

Flow diagram, Fig. 3

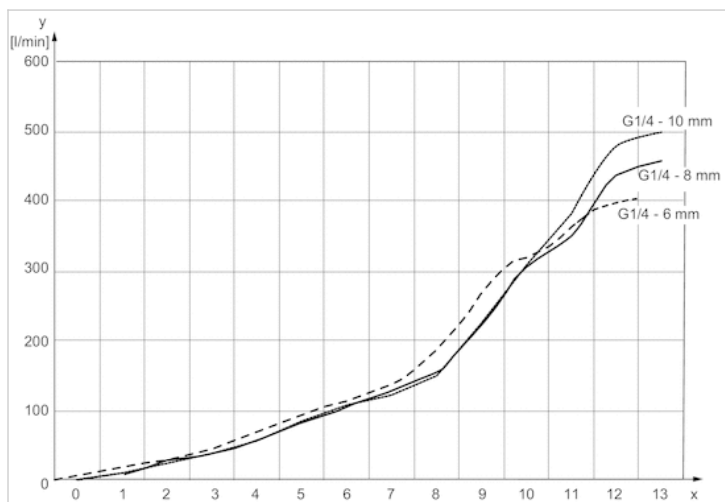

x = rotations of the throttle screw
 y = flow rate Qn

Flow diagram, Fig. 4

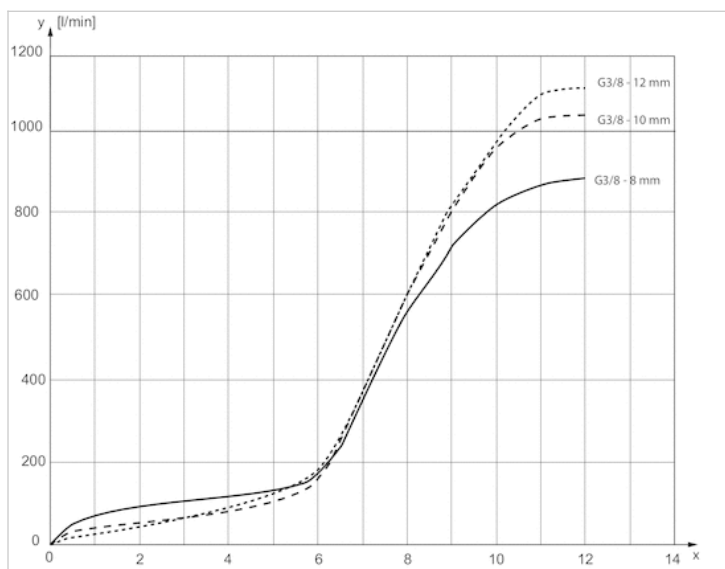

x = rotations of the throttle screw
 y = flow rate Qn

Flow diagram, Fig. 5

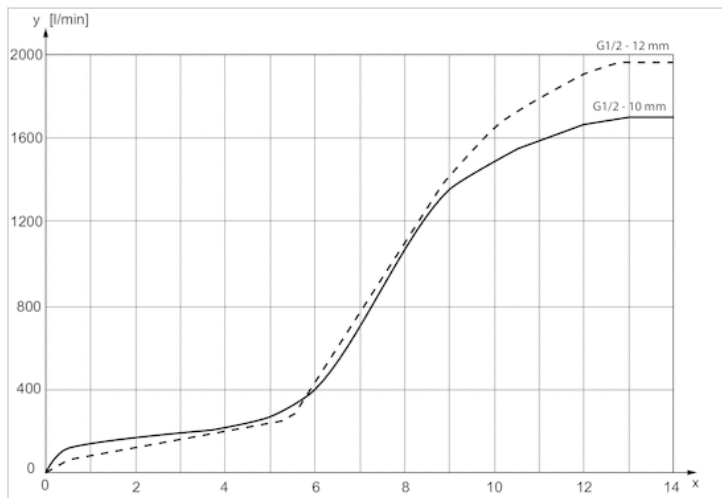

x = rotations of the throttle screw

y = flow rate Q_n