

DATE	DESCRIPTION	REV.

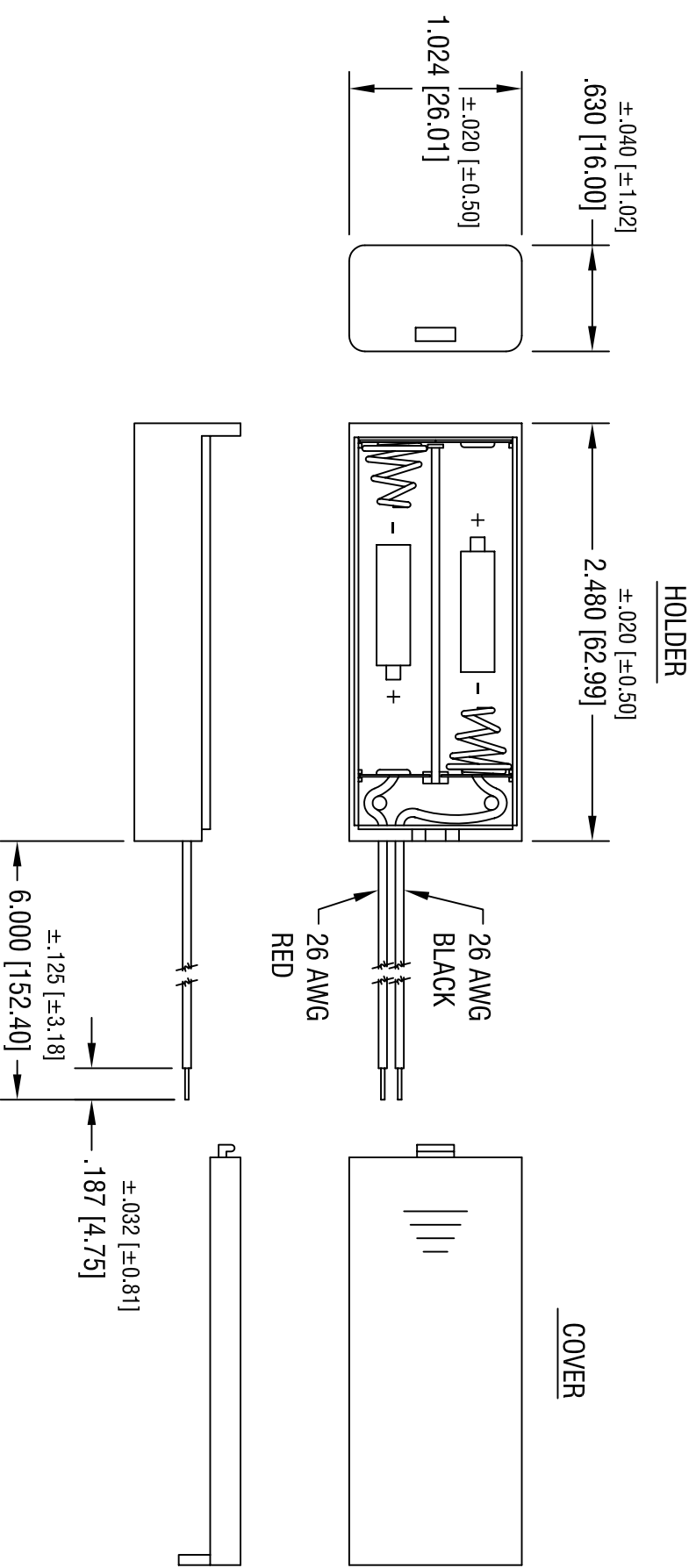

- NOTE:
- HOLDER: MAT'L: A.B.S., BLACK
 WIRE: 26 AWG, 1007 UL/CSA APPROVED
 SPRING: MAT'L: MUSIC WIRE, .020 [0.50] DIA.
 FINISH: NICKEL PLATE

KEYSTONE ELECTRONICS CORP.			
ASTORIA, N.Y. 11105-2017			
PART NAME		BATTERY HOLDER & COVER, (2) YAAI	
MATERIAL		AS NOTED	
FINISH		AS NOTED	
TOLERANCES	INCH	[MM]	CODE
DECIMAL	± .015	[± 0.38]	C/M
ANGULAR	± 1°		
DRN BY	BOONE	DATE	5.4.05
App'D	LN	SCALE	1X
DWG NO.	2489		

THIS DOCUMENT IS THE PROPERTY OF KEYSTONE ELECTRONICS CORP. AND SHALL NOT BE REPRODUCED, DISTRIBUTED OR USED AS A BASIS FOR MANUFACTURE WITHOUT PRIOR WRITTEN PERMISSION FROM KEYSTONE ELECTRONICS CORP.

Mouser Electronics

Authorized Distributor

Click to View Pricing, Inventory, Delivery & Lifecycle Information:

[Keystone Electronics:](#)

[2489](#)