

CUSTOMER DRAWING

SHEET 2 ONLY

REV.	DATE	D.C.N. NUMBER	DESCRIPTION	CHECKED BY DATE	APPROVED BY DATE
1	02/04/08		FIRST ISSUE	NAME dd/mm/yy	NAME dd/mm/yy
1 A	17/03/11	03/11/1291	NOTE CHANGE + DIM CHANGE	NAME dd/mm/yy	NAME dd/mm/yy
1 B	05/12/11	12-11-1322	DRAWING UPDATED WITH NEW DRW. STANDARDS AND NEW CARCLO OPTICS FORMAT FOR FULL DETAILS SEE D.C.N	PW 16/07/12	MH 16/07/12

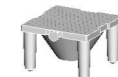
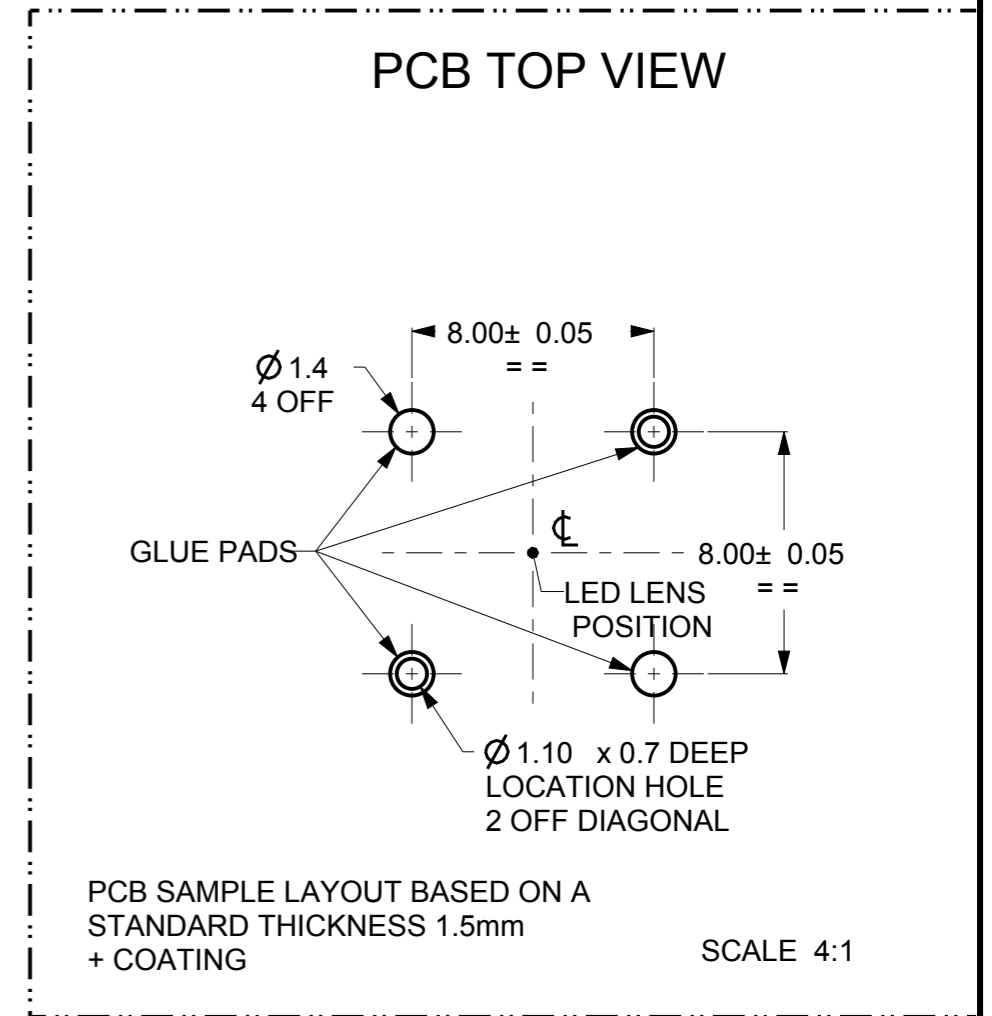
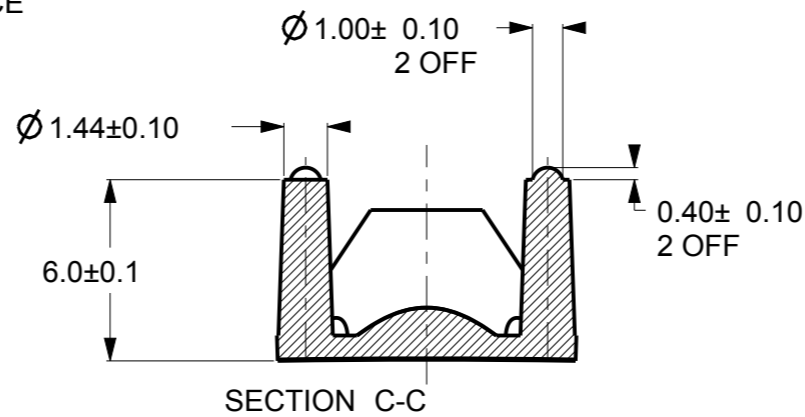
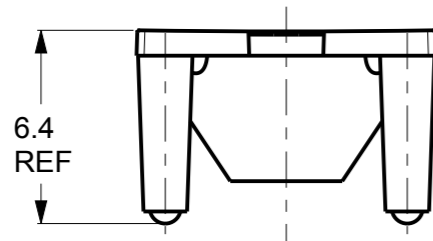
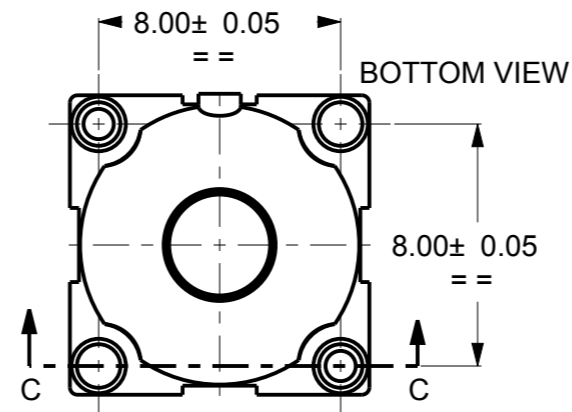
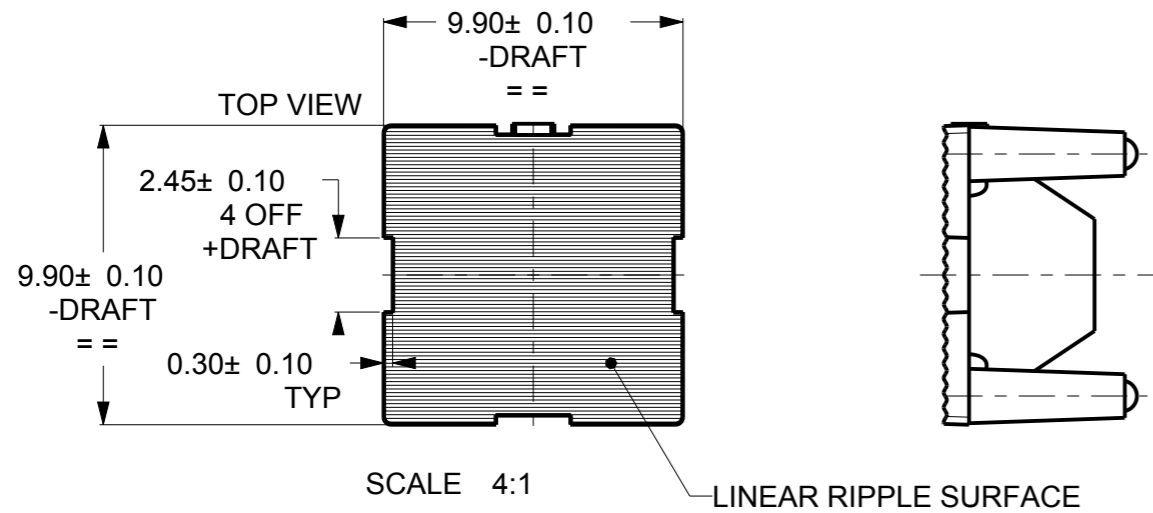

SCALE 1:1

NOTES:

- 1 - MATERIAL: POLYCARBONATE
- 2 - FINISH: COMMERCIAL POLISH FOR ALL NON OPTICAL SURFACES. OPTICAL SURFACES ARE OPTICALLY POLISHED
- 3 - OVERALL PART THICKNESS = SEE 3D FILE
- 4 - COLOUR CLEAR
- 5 - GENERAL DRAFT 2°
- 6 - SIMPLIFIED GEOMETRY SHOWN. NOT SUITABLE FOR OPTICAL RAYTRACE

		Title		10mm SQUARE ELLIPTICAL BEAM OPTIC					
103 Buckingham Avenue, SL1 4PF, U.K. Tel: +44 (0)1753 575 011 Fax: +44 (0)1753 811 359 sales@carclo-optics.com www.carclo-optics.com		Drawn by	FP	Customer	CARCLO		Scale	AS SPEC.	
THIRD ANGLE PROJECTION 		GENERAL TOLERANCES UNLESS OTHERWISE STATED LINEAR ANGULAR 0 ± 0.25 0 ± 1° 0.0 ± 0.1 0.0 ± 0.5° 0.00 ± 0.05 0.00 ± 0.1°		CARCLO Optics CONFIDENTIAL: UNAUTHORISED COPYING, DISCUSSION & DISTRIBUTION PROHIBITED		DIMENSIONS IN mm Format Size A3		CAD File 60518 Part N° 10415 Drw N° 60518	