

Low current consumption
I²C-Bus INTERFACE REAL TIME CLOCK MODULE

RTC - 8564 JE / NB
RX - 8564 LC

- Built in frequency adjusted 32.768 kHz crystal unit.
- Interface Type : I²C-Bus Interface (400 kHz)
- Operating voltage range : 1.8 V to 5.5 V
- Timekeeper voltage range : 1.0 V to 5.5 V / -20 °C to +70 °C
- Low backup current : 275 nA / 3.0 V(Typ.)
- 32.768 kHz frequency output function : C-MOS output With Control Pin
- The various functions include full calendar, alarm, timer, and power supply voltage monitoring function

* The I²C-Bus is a trademark of NXP Semiconductors



Product Number (Please contact us)
 RTC-8564JE : Q41856471000100
 RTC-8564NB : Q41856492000200
 RX-8564LC : Q418564C2xxxx00



Actual size



Block diagram

Overview

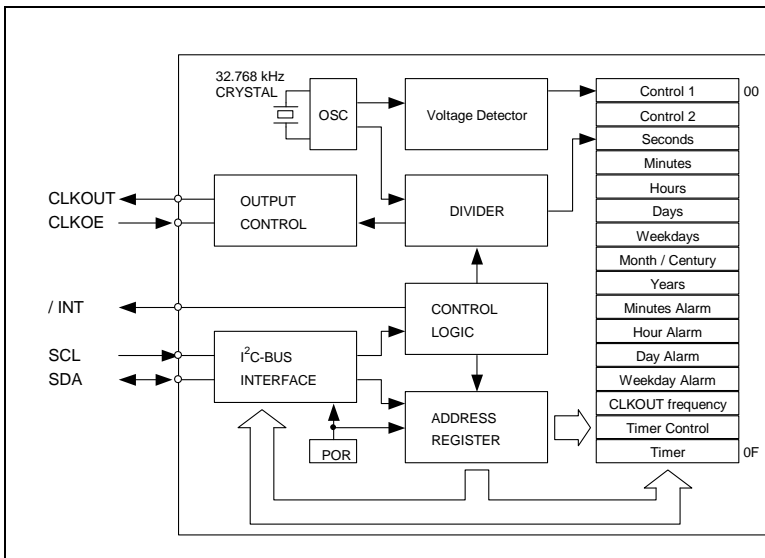

Interface Type

- I²C-Bus Interface. (Hi-speed bus specifications 400 kHz)
- * I²C-Bus slave address : read A3h and write A2h

Low Timekeeper voltage range

- 1.0 V to 5.5 V / Ta = -20 °C to +70 °C
- 1.1 V to 5.5 V / Ta = -40 °C to +85 °C

32.768 kHz frequency output function

- CLKOUT pin output (C-MOS output), CL=30 pF
- CLKOE pin enables output on/off control.
- Output selectable
 <32.768 kHz, 1024 Hz, 32 Hz, 1 Hz>

The various interrupt function

- Timer function can be set up between 1/4096 second and 255 minutes.
- Alarm function can be set to any combination of day of week, hour, or minute.

Pin Function

Terminal connection / External dimensions

(Unit:mm)

Signal Name	Input/Output	Function											
SCL	Input	Serial clock input pin.											
SDA	Bi-directional	Data input and output pin.											
CLKOUT	Output	32.768 kHz clock output pin with the output control function. (C-MOS) CLKOE pin control the condition of CLKOUT with FE-bit, etc.											
CLKOE	Input	<table border="1"> <thead> <tr> <th>CLKOE pin input</th> <th>FE bit</th> <th>CLKOUT pin output</th> </tr> </thead> <tbody> <tr> <td>HIGH</td> <td>1</td> <td>Output (C-MOS)</td> </tr> <tr> <td rowspan="2">LOW</td> <td>0</td> <td>OFF (LOW)</td> </tr> <tr> <td>0</td> <td>OFF (LOW)</td> </tr> </tbody> </table>	CLKOE pin input	FE bit	CLKOUT pin output	HIGH	1	Output (C-MOS)	LOW	0	OFF (LOW)	0	OFF (LOW)
CLKOE pin input	FE bit	CLKOUT pin output											
HIGH	1	Output (C-MOS)											
LOW	0	OFF (LOW)											
	0	OFF (LOW)											
/INT	Output	Interrupt output (N-ch open drain)											
VDD	—	Connected to a positive power supply.											
GND	—	Connected to a ground.											

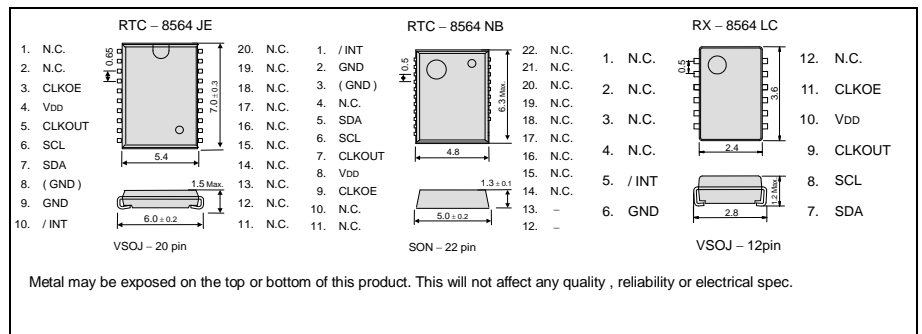

Specifications (characteristics)

* Refer to application manual for details.

Recommended Operating Conditions

Item	Symbol	Condition	Min.	Typ.	Max.	Unit
Power voltage	VDD	—	1.8	3.0	5.5	V
Clock voltage	VCLK	—	VLow	3.0	5.5	V
Operating temperature	TOPR	—	-40	+25	+85	°C

Low voltage detection

Item	Symbol	Condition	Typ.	Max.	Unit	
Low voltage detection	VLow	JE, NB	Ta = -20 °C ~ +70 °C	0.9	1.0	V
			Ta = -40 °C ~ +85 °C	0.9	1.1	V
		LC	Ta = -20 °C ~ +70 °C	0.9	1.2	V
			Ta = -40 °C ~ +85 °C	0.9	1.3	V

Frequency characteristics

Item	Symbol	Condition	Rating	Unit
Frequency tolerance	Δf/f	Ta = +25 °C VDD = 3.0 V	5 ± 23 *	× 10 ⁻⁶

* Please ask for tighter tolerance. (Equivalent to 1 minute of monthly deviation)

Current consumption characteristics

Ta = -40 °C to +85 °C

Item	Symbol	Condition	Min.	Typ.	Max.	Unit
Current Consumption	I _{BK}	f _{SCL} = 0 Hz CLKOE = GND	VDD = 5 V	330	800	nA
		CLKOUT ; output OFF (LOW)	VDD = 3 V	275	700	
	I _{32k}	f _{SCL} = 0 Hz CLKOE = VDD	VDD = 5 V	2.5	3.4	μA
		CLKOUT ; 32.768 kHz output ON (Output=OPEN ; CL = 0 pF)	VDD = 3 V	1.5	2.2	