

Connector Hood with ESD Protection Simplifies Circuit Design

- Non-conductive surface protects against ESD (static electricity).
- Internal grounding provides EMI protection.
- Screwdrivers eliminated by overmold jackscrews.

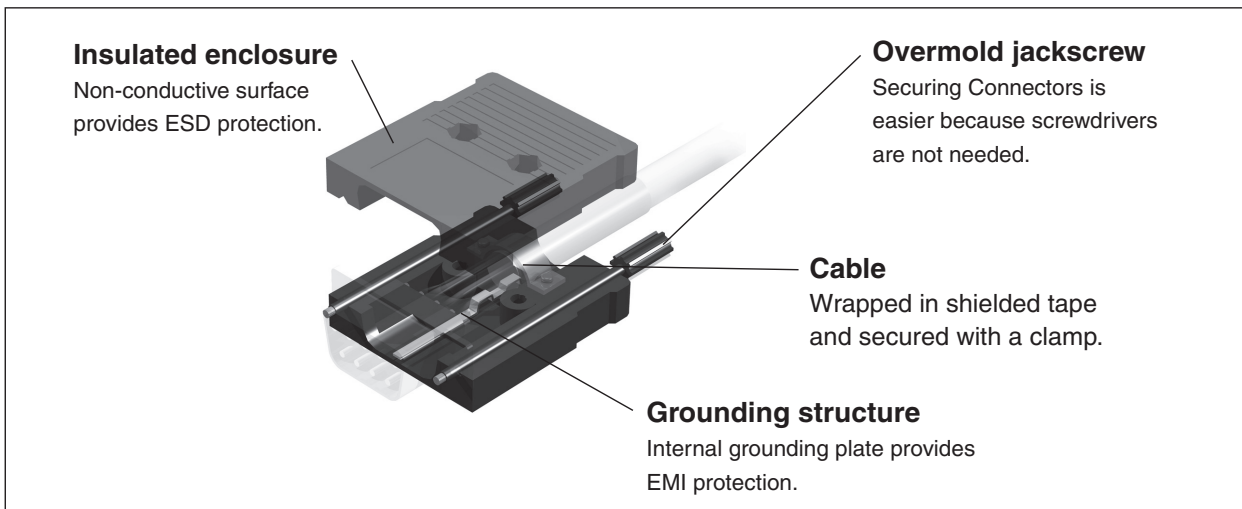

■ Structural Diagram (Assembled)



■ Performance, Materials, and Finishes

| | |
|-------------------------------|--|
| Ambient operating temperature | - 25 to 85°C (with no condensation or icing) |
| Cover | ABS (UL94 V-0)/black |
| Grounding plate | Phosphor bronze/nickel plating |
| Jackscrew | ABS (UL94 V-0)/black |

■ Dimensions

(unit: mm)

XM2S-0911-E
D-sub Connector Assembly Hood with ESD Protection

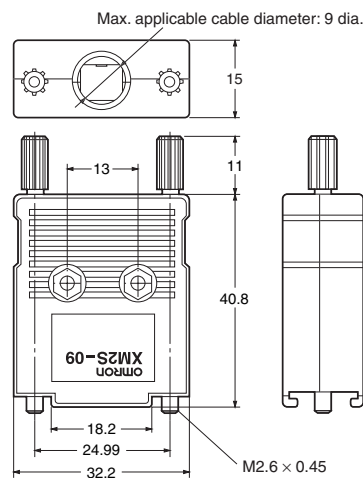
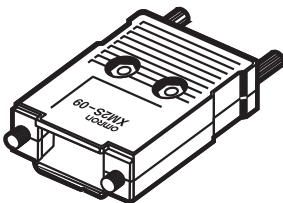

■ Ordering Information

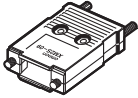
| Type | Appearance | No. of contacts | Model |
|---|---|-----------------|-------------|
| D-sub Connector Assembly Hood with ESD protection |  | 9 | XM2S-0911-E |

■ Precautions

Correct Use

- Use a torque of 0.25 N·m to secure the cable clamp to the Hood.
- When you tighten the jack screws, hold the hood and make sure that the Connector is connected straight. If the screws are tightened when the Connector is not connected completely, the Connector may be damaged.
- Always use your fingers to tighten the jack screws. If you use pliers or any other tool to tighten the jack screws, the screws may be damaged.

■ Approval Standard

The approval rating values for overseas standards are different from the performance values determined individually. Confirm the values before use.

| Model | Standard | File No. | Rating |
|-------------|---------------------|----------|--------|
| XM2S-0911-E | Non Approved Models | --- | --- |

Please check each region's Terms & Conditions by region website.

OMRON Corporation

Device & Module Solutions Company

Regional Contact

Americas

<https://components.omron.com/us>

Asia-Pacific

<https://components.omron.com/ap>

Korea

<https://components.omron.com/kr>

Europe

<https://components.omron.com/eu>

China

<https://components.omron.com.cn>

Japan

<https://components.omron.com/jp>