

MOC8101X, MOC8102X, MOC8103X,
MOC8104X, MOC8105X MOC8101,
MOC8102, MOC8103, MOC8104, MOC8105



ISOCOM
COMPONENTS

**NON-BASE LEAD
OPTICALLY COUPLED ISOLATOR
PHOTOTRANSISTOR OUTPUT**



APPROVALS

- UL recognised, File No. E91231
Package Code " GG "
- 'X' SPECIFICATION APPROVALS
 - VDE 0884 in 3 available lead form :-
 - STD
 - G form
 - SMD approved to CECC 00802
 - Certified to EN60950 by :-
Nemko - Certificate No. P01102464

DESCRIPTION

The MOC8101, MOC8102, MOC8103, MOC8104, MOC8105 series of optically coupled isolators consist of infrared light emitting diode and NPN silicon photo transistor in a standard 6 pin dual in line plastic package with the base pin unconnected.

FEATURES

- Options :-
 - 10mm lead spread - add G after part no.
 - Surface mount - add SM after part no.
 - Tape & reel - add SMT & R after part no.
- High Isolation Voltage ($5.3kV_{RMS}$, $7.5kV_{PK}$)
- Base pin unconnected for improved noise immunity in high EMI environment

APPLICATIONS

- DC motor controllers
- Industrial systems controllers
- Signal transmission between systems of different potentials and impedances

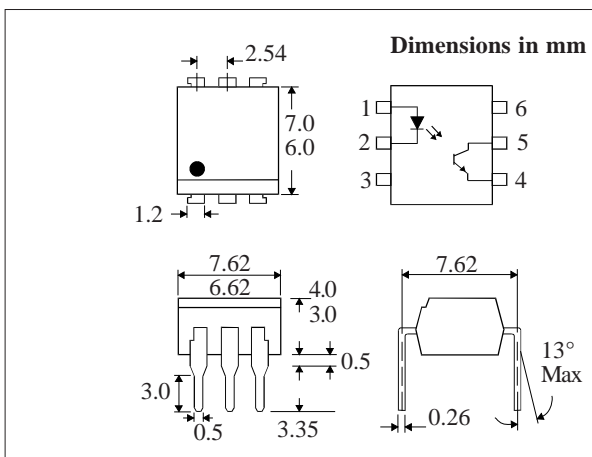
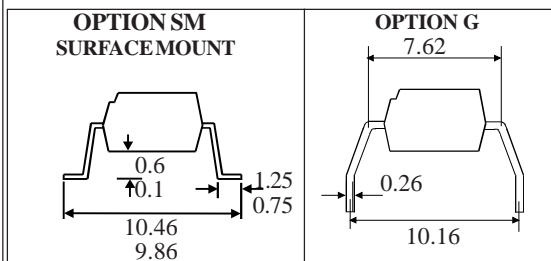

**ABSOLUTE MAXIMUM RATINGS
(25°C unless otherwise specified)**

Storage Temperature _____ -55°C to +150°C
Operating Temperature _____ -55°C to +100°C
Lead Soldering Temperature
(1/16 inch (1.6mm) from case for 10 secs) 260°C

INPUT DIODE

Forward Current _____ 60mA
Reverse Voltage _____ 6V
Power Dissipation _____ 105mW

OUTPUT TRANSISTOR

Collector-emitter Voltage BV_{CEO} _____ 30V
Emitter-collector Voltage BV_{ECO} _____ 6V
Collector Current _____ 50mA
Power Dissipation _____ 160mW

POWER DISSIPATION

Total Power Dissipation _____ 200mW
(derate linearly 2.67mW/°C above 25°C)

ISOCOM COMPONENTS 2004 LTD
Unit 25B, Park View Road West,
Park View Industrial Estate, Brenda Road
Hartlepool, Cleveland, TS25 1UD
Tel: (01429) 863609 Fax: (01429) 863581

ELECTRICAL CHARACTERISTICS ($T_A = 25^\circ\text{C}$ Unless otherwise noted)

PARAMETER		MIN	TYP	MAX	UNITS	TEST CONDITION
Input	Forward Voltage (V_F)	1.0	1.15	1.5	V	$I_F = 10\text{mA}$
	Reverse Current (I_R)			10	μA	$V_R = 6\text{V}$
Output	Collector-emitter Breakdown (BV_{CEO}) (Note 2)	30			V	$I_C = 1\text{mA}$
	Emitter-collector Breakdown (BV_{ECO})	6			V	$I_E = 100\mu\text{A}$
	Collector-emitter Dark Current (I_{CEO})			50	nA	$V_{CE} = 10\text{V}$
Coupled	Output Collector Current (I_C) (Note 3)					
	MOC8101	5.0		8.0	mA	$10\text{mA } I_F, 10\text{V } V_{CE}$
	MOC8102	7.3		11.7	mA	$10\text{mA } I_F, 10\text{V } V_{CE}$
	MOC8103	10.8		17.3	mA	$10\text{mA } I_F, 10\text{V } V_{CE}$
	MOC8104	16		25.6	mA	$10\text{mA } I_F, 10\text{V } V_{CE}$
	MOC8105	6.5		13.3	mA	$10\text{mA } I_F, 10\text{V } V_{CE}$
	Collector-emitter Saturation Voltage $V_{CE(SAT)}$		0.15	0.4	V	$5\text{mA } I_F, 0.5\text{mA } I_C$
	Input to Output Isolation Voltage V_{ISO}	5300			V_{RMS}	See note 1
		7500			V_{PK}	See note 1
	Input-output Isolation Resistance R_{ISO}	5×10^{10}			Ω	$V_{IO} = 500\text{V}$ (note 1)
Response Time (Rise), tr		2		μs	$V_{CC} = 5\text{V}, I_F = 10\text{mA}$	
Response Time (Fall), tf		2		μs	$R_L = 75\Omega$, (FIG 1)	

- Note 1 Measured with input leads shorted together and output leads shorted together.
 Note 2 Special Selections are available on request. Please consult the factory.
 Note 3 Production testing - limits verified with pulse test

FIGURE 1

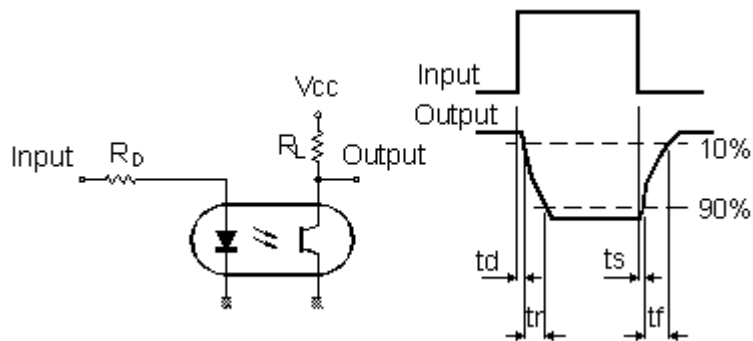

Collector Power Dissipation vs. Ambient Temperature



Collector Current vs. Collector-emitter Voltage

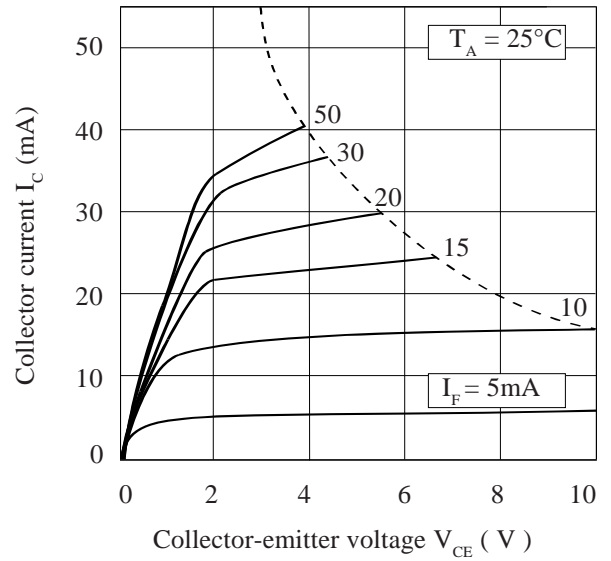

Forward Current vs. Ambient Temperature

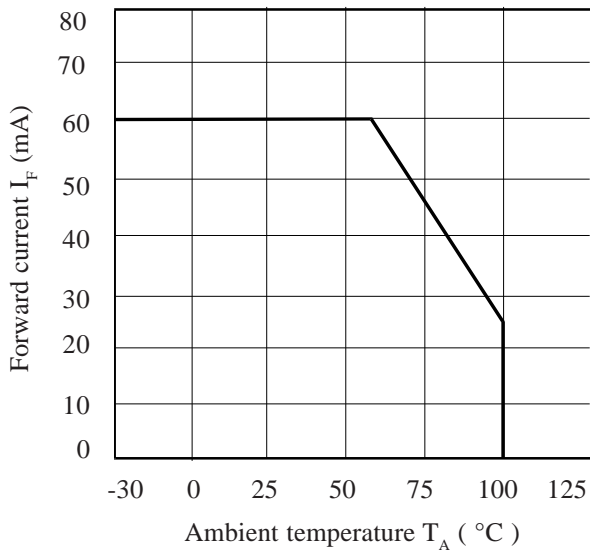

Current Transfer Ratio vs. Forward Current

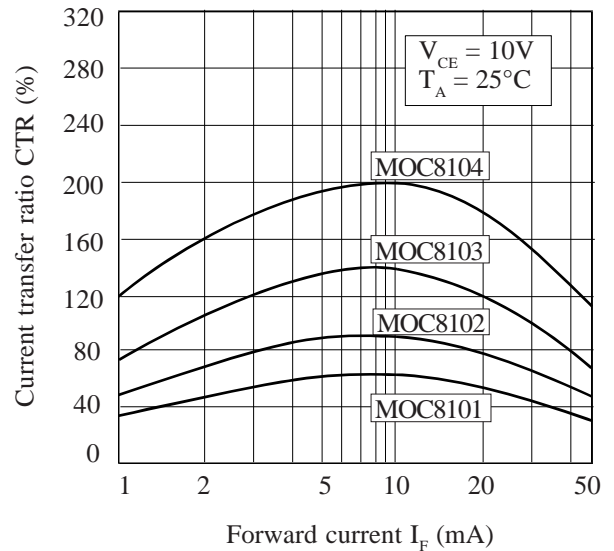

Relative Current Transfer Ratio vs. Ambient Temperature

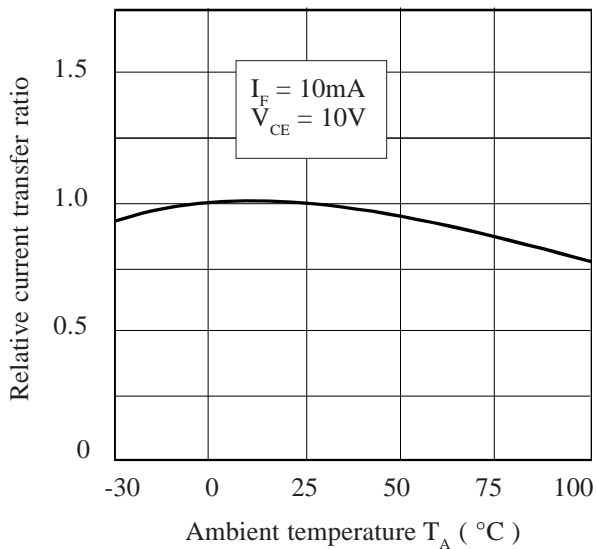

Collector-emitter Saturation Voltage vs. Ambient Temperature

