

Low Power Wireless Current Sense

INTRODUCTION

The DC2369A demo circuit is a reference design that implements a wireless current sense solution using Linear Technology's low power integrated circuits. The only external connection needed is the current to be measured, allowing this circuit to be inserted at any voltage level or isolation level.

The design combines components for current measurement, power management and wireless mesh networking. A micro-power zero-drift op amp ([LTC®2063](#)) amplifies the voltage across a sense resistor. A 16-bit SAR ADC and precision reference ([AD7988](#) and [LT®6656](#)) digitize the reading. A SmartMesh IP™ wireless radio module

([LTP5901-IPM](#)) runs the application, provides the wireless mesh connectivity and communicates with a central network manager. A switching power supply ([LTC3335](#)) counts the cumulative charge drawn from the included battery while also regulating the output voltage for the rest of the application. Table 1 shows featured components used along with their function.

Design files for this circuit board are available at <http://www.linear.com/demo/DC2369A>

LT, LT, LTC, LTM, Linear Technology, SmartMesh and the Linear logo are registered trademarks and SmartMesh IP is a trademark of Analog Devices, Inc. All other trademarks are the property of their respective owners.

Table 1

LTC PART NUMBER	FUNCTION	BENEFITS
LTC2063	2µA Zero-Drift Op Amp	Measures Small Voltage Drop Across Sense Resistor to Measure Current
AD7988-1	100ksps Ultra Low Power 16-Bit SAR ADC	Digitizes Measurement from Op Amp While Consuming <1µA at Low Sample Rate
LT6656-3	1µA Precision Voltage Reference	<10ppm/°C Reference for Stable ADC Measurement. Provides Low Noise Supply for Op Amp
LTP5901-IPM	SmartMesh IP Mote Module	Automatically Forms Low Power, Reliable Wireless Network. Built-In Microprocessor Manages ADC and Power Supplies
LTC3335	Nanopower Buck-Boost DC/DC with Integrated Coulomb Counter	Measures Total Charge Drawn from Battery. Regulates Output Supply for Rest of Application

DC2369A CONNECTIONS AND JUMPERS

1. Set the slide switch SW1 to ON to power on the circuit. DC2369A is powered from its included two AAA batteries and therefore does not need an external power supply. The slide switch asserts the enable pin of the LTC3335. You may verify correct operation of the power supplies by measuring (on the back of the circuit board) that $V_{DD} - GND = 3.3V$ and $V_{REF} - GND = 3.0V$.
2. The only external connection needed to the DC2369A is for the current to be measured. The DC2369A circuitry does not draw its power from this current – it only uses it to develop a small voltage drop across the included 10mΩ sense resistor. The DC2369A is designed to measure up

to ±1A full-scale current, developing a ±10mV voltage drop across the sense resistor. Connect the current to be measured using the banana connectors (J2 and J3). Set jumpers JP1 and JP2 to the INT position (to use the internal sense resistor). See Figure 1.

3. Alternatively, DC2369A can be used to measure the voltage across an external sense resistor. In this case, set jumpers JP1 and JP2 to EXT, and connect the voltage to be measured to the turrets labeled V_{IN}^+ and V_{IN}^- . The preconfigured DC2369A firmware and software will still assume a ±10mV full-scale input voltage and report that as a ±1A full-scale current. See Figure 2.

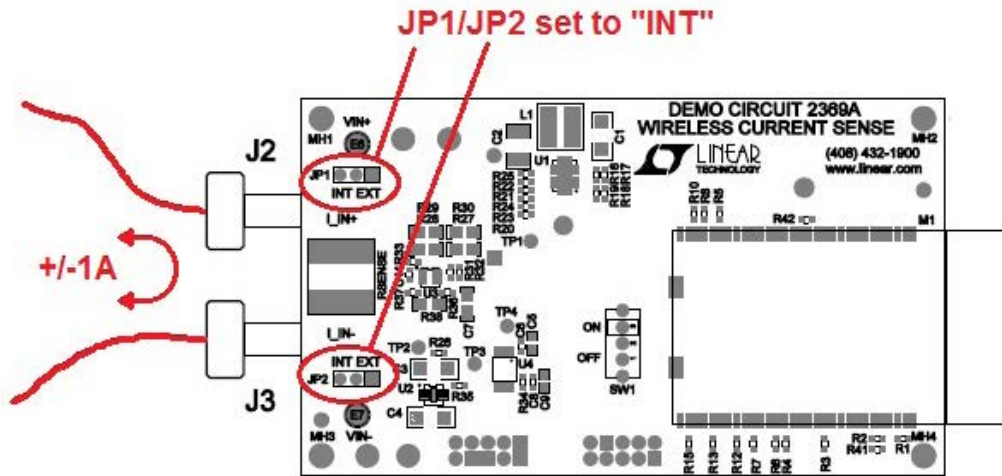

Figure 1. DC2369A Connections and Jumpers for Internal Sense Resistor

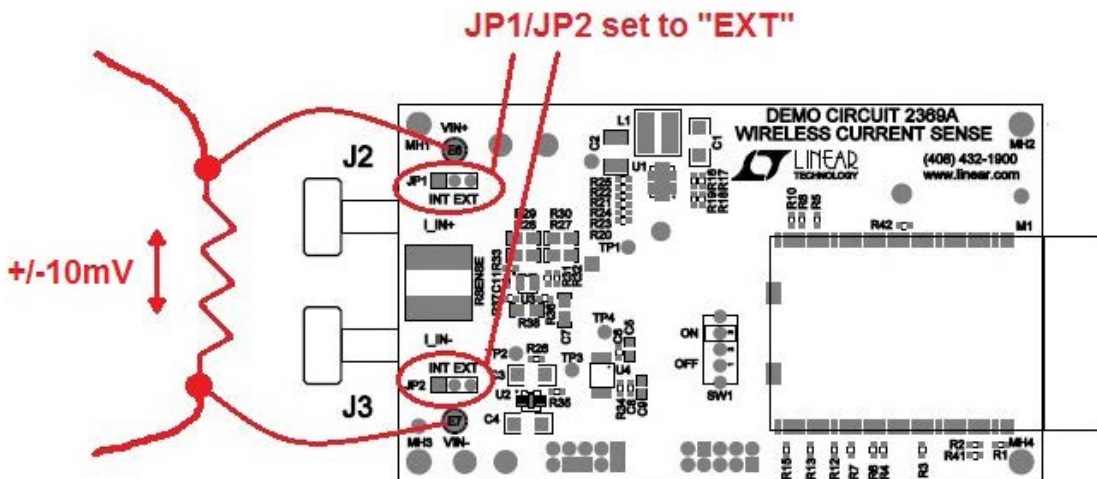

Figure 2. DC2369A Connections and Jumpers for External Sense Resistor

INSTALL THE DC2369A GUI

For demonstration purposes, a small sample Python based graphical user interface (GUI) application was designed to subscribe to all incoming DC2369A device messages and display the data.

For more information on programming to the manager software application programming interface (API), refer to the [SmartMesh IP Embedded Manager API Guide](#).

1. Install FTDI USB-to-Serial Drivers

In order for your computer to communicate with the Manager, you may first need to install a driver from [FTDI](#). You should be able to simply follow the instructions within the driver installer, but detailed instructions are also available in the Setup section of the [SmartMesh IP Tools Guide](#).

2. Download GUI

The DC2369A GUI is found with this demo circuit's documentation on www.linear.com/demo. Download and extract the zip file to a convenient location on your computer.

FORM THE WIRELESS NETWORK

This document assumes some basic familiarity with SmartMesh IP wireless networking. Refer to the [SmartMesh IP Easy Start Guide](#) if needed.

1. Use any SmartMesh IP manager such as the [DC2274A-A SmartMesh IP USB Network Manager](#). Be aware of the manager's network ID.

2. Turn on power to at least three SmartMesh IP motes, operating on the same network ID as the manager. DC2369A will co-exist in a network with any other SmartMesh IP motes (of the same network ID), such as motes from the [SmartMesh IP Starter Kit DC9021B](#).

3. All DC2369A motes are shipped factory-programmed to the default network ID of 1229. This is the same network ID programmed by default into the standard SmartMesh IP evaluation kits. If it is needed to change the network ID of this mote to match the one used in your network, the DC2369A API or CLI can be accessed through the 10-pin connector labeled J1 PROG on the back of the board.

4. Connect the manager to a computer USB port. The network should now form. Proper operation of the network can be monitored by accessing the manager CLI or API in the usual manner.

5. Open the DC2369A GUI. You will see a window similar to that shown in Figure 3.

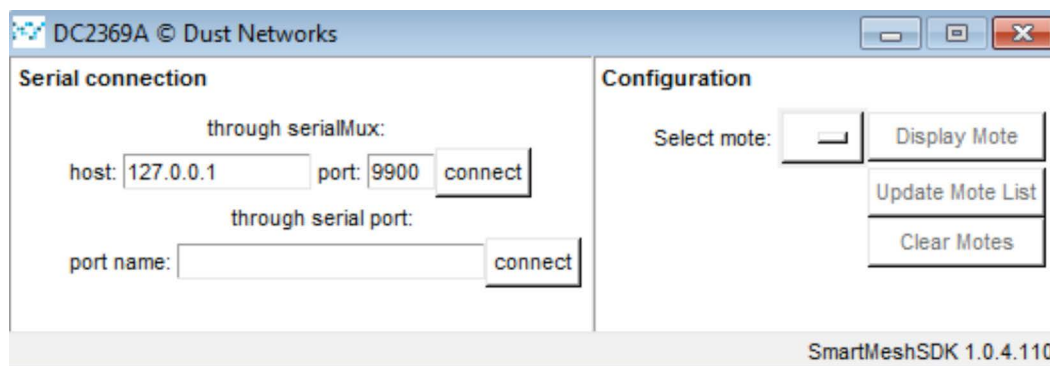

Figure 3. DC2369A GUI Start-Up Window

FORM THE WIRELESS NETWORK

6. In the port name field, enter the COM port that corresponds to the Manager API. This is typically the last of the four COM ports added. Then click the connect button. The GUI window will change as shown in Figure 4 if connection is successful.

If you don't know what the Manager API COM port is, refer to the [SmartMesh IP Tools Guide](#) for instructions.

7. To select a mote for display, see the Select mote: pull down menu in the Configuration section, and select from the list of connected motes. The pull-down list will be populated with the MAC address of all DC2369A motes that are found on the network. The last few digits of

these MAC addresses can also be found on a label on your DC2369A motes. Click on Display Mote. The GUI window will change similar to Figure 5.

8. Measured Current (A) shows the current measured between the DC2369A input connectors. Used battery life shows an estimation of the percentage of the AAA batteries that has been used since last reset, based on the coulomb counter reading of the mote's LTC3335 power supply. This will likely start at 0.0% when the mote first powers up, and will only change after many hours of operation.

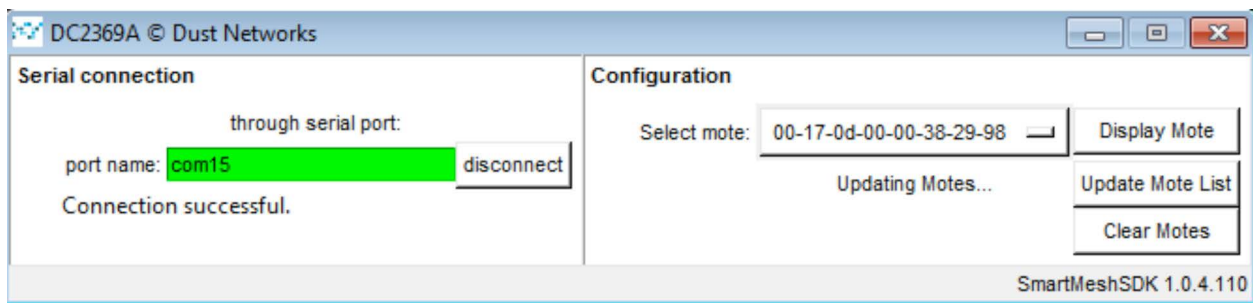

Figure 4. DC2369A GUI Successful Connection

FORM THE WIRELESS NETWORK

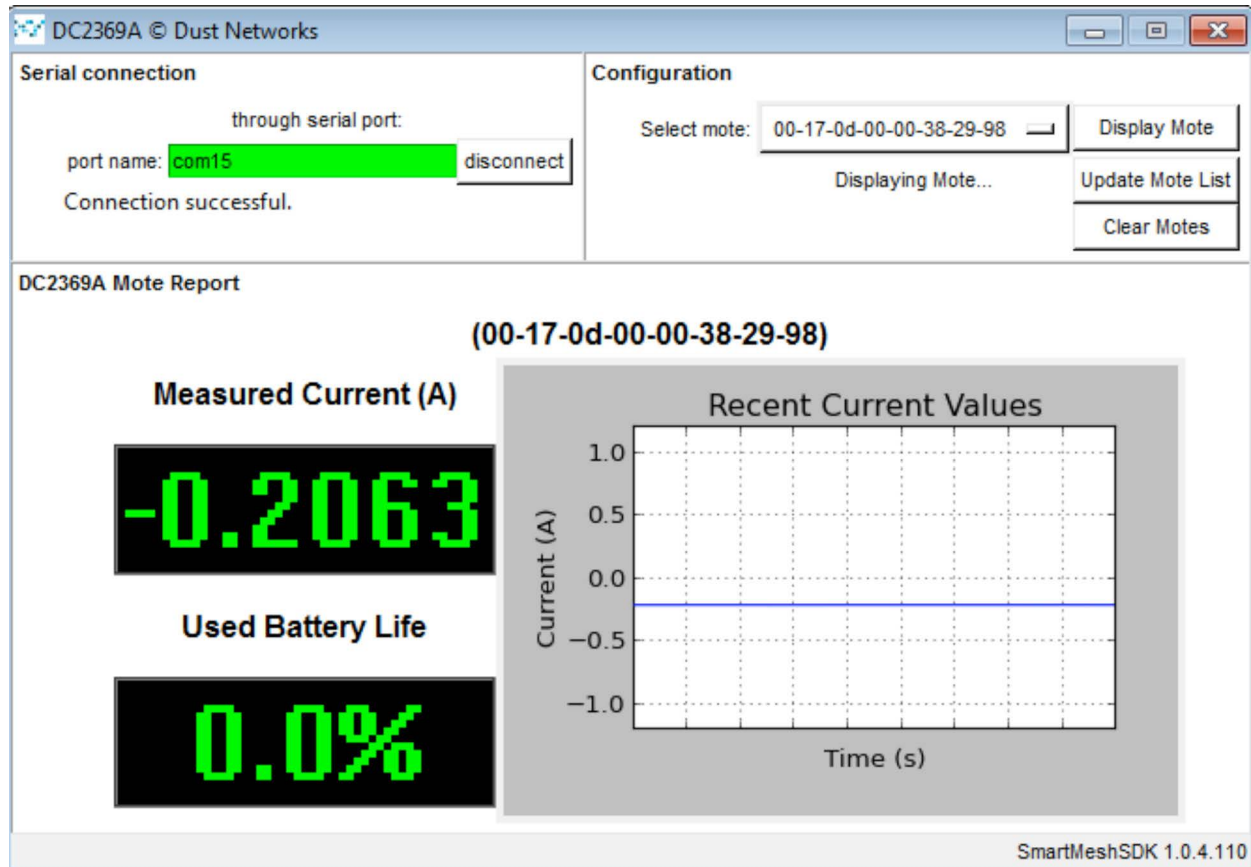

Figure 5. DC2369A GUI Showing Example Data for a Mote

SOURCE CODE

1. DC2369A has been preprogrammed with custom firmware that runs on the internal microprocessor of the LTP5901-IPM. This firmware has been created in the SmartMesh IP On-Chip SDK (OCSDK), and can be accessed on [Github](#).
2. The DC2369A GUI has been created in Python, built on the SmartMesh® SDK. The source code can be accessed on [Github](#).

DEMO MANUAL DC2369A

PARTS LIST

ITEM	QTY	REFERENCE	PART DESCRIPTION	MANUFACTURER/PART NUMBER
Required Circuit Components				
1	1	BTH1	BATTERY HOLDER, 2CELL AAA, PC MNT	KEYSTONE, 2468K-ND
2	1	C1	CAP, CHIP, X5R, 22 μ F, 20%, 6.3V, 1206	SAMSUNG, CL31A226MQHNNNE
3	1	C2	CAP, CHIP, X5R, 150 μ F, 20%, 6.3V, 1210	SAMSUNG, CL32A157MQVNNNE
4	2	C3, C4	CAP, CHIP, X7R, 22 μ F, \pm 10%, 10V, 1206	MURATA, GRM31CR71A226KE15L
5	2	C5, C9	CAP, CHIP, X7R, 1 μ F, \pm 10%, 10V, 0603	TDK, C1608X7R1A105K080AC
6	3	C6, C8, C11	CAP, CHIP, X7R, 0.1 μ F, \pm 10%, 10V, 0402	TDK, C1005X7R1A104K050BB
7	1	C7	CAP, CHIP, X7R, 10 μ F, \pm 10%, 10V, 0805	TDK, C2012X7R1A106K125AC
8	6	E1, E2, E3, E4, E6, E7	TURRET, 0.061 DIA	MILL-MAX, 2308-2-00-80-00-00-07-0
9	2	J1, J4	5 x 2 HEADER 2MM	MOLEX, 87831-1020
10	1	J2	BANANA JACK, RED	CONN SOLUTIONS, 108-0902-001
11	1	J3	BANANA JACK, BLACK	CONN SOLUTIONS, 108-0903-001
12	2	JP1, JP2	HEADER, 2MM, 1X3POS	SAMTEC, TMM-103-02-L-S
13	2	JP1, JP2	SHUNT, 2MM	SAMTEC, 2SN-KB-G
14	1	L1	IND, SMT, 100 μ H, 1.40, 350mA, 4mm x 4mm x 1.8mm	COILCRAFT, LPS4018-104MLB
15	1	M1	SmartMesh IP MOTE MODULE	LINEAR TECH, LTP5901PC-IPMA#PBF
16	4	R1, R2, R5, R8	RES, CHIP, 100k Ω , 1% 1/10W 0402	VISHAY MCS04020C1003FE000
17	8	R3, R4, R6, R17, R20, R22, R24, R26	RES, CHIP, 0.0 Ω JUMPER, 1/16W	VISHAY CRCW040220000Z0ED
18	5	R7, R10, R12, R13, R15	RES, CHIP, 34 Ω , 1% 1/10W 0402	PANASONIC, ERJ-2RKF34R0X
19	0	R16, R21, R23, R25, R31, R32, R41	OPTIONAL, DO NOT POPULATE	
20	2	R18, R19	RES, CHIP, 4.99k Ω , 1% 1/10W 0402	PANASONIC, ERJ-2RKF4991X
21	5	R27, R28, R29, R30, R38	RES, CHIP, 2M Ω , \pm 0.1%, 1/10W, 0805	TE CONNECTIVITY, CPF0805B2MOE1
22	2	R33, R37	RES, CHIP, 14k Ω , \pm 0.1%, 1/16W, 0402	TE CONNECTIVITY, CPF0402B14KE1
23	1	R36	RES, CHIP, 10k Ω , 1/10W, 0402	PANASONIC ERJ-2RKF1002X
24	1	R42	RES, CHIP, 237 Ω , 1%, 1/16W, 0402	VISHAY CRCW0402237RFKED
25	1	RSENSE	RES, CHIP, 0.01 Ω , \pm 0.5%, \pm 15PPM/C, 3W, 2728	STACKPOLE ELECTRONICS, CSS2728DT10L0
26	1	SW1	SLIDE SWITCH SPDT	C&K COMPONENTS, OS102011MS2QN1
27	1	U1	IC, SMT, NANOPOWER BUCK-BOOST WITH COULOMB COUNTER, 3mm x 4mm, QFN20	LINEAR TECH, LTC3335EUDC#PBF
28	1	U2	IC, SMT, MICROPOWER VOLTAGE REFERENCE, 2mm x 3mm, DFN6	LINEAR TECH, LT6656AIDC-3#PBF
29	1	U3	IC, SMT, MICROPOWER ZERO-DRIFT OPAMP, SC70	LINEAR TECH, LTC2063ISC#PBF
30	1	U4	IC, SMT, 16-BIT ULTRA LOW POWER ADC, 10ID LFCSP 3mm x 3mm	ANALOG DEVICES, AD7988-1BCPZ-RL7
31	4	MH1 TO MH4	STAND-OFF, NYLON, HEX, #4-40, 3/4 INCH TALL	KEYSTONE 1902D
32	4	MH1 TO MH4	SCREW, NYLON, #4-40, 1/2 INCH	KEYSTONE 9529
33	2	TO SECURE BTH1	SCREW, NYLON, 2-56, 1/4 INCH	B&F NY PMS 256 0025 PH
34	2	TO SECURE BTH1	NYLON HEX NUT 2-56	B&F NY HN 256
35	2	BAT1, BAT2 TO PLUG INTO BATTERY HOLDER	BATTERY LITHIUM AAA 1.5V PRIMARY CELL	ENERGIZER L92
36	1		FAB, PRINTED CIRCUIT BOARD	DEMO CIRCUIT DC2369A-5
37	2		STENCILS, DC2369A - TOP AND BOTTOM	STENCILS, # DC2369A-5

SCHEMATIC DIAGRAM

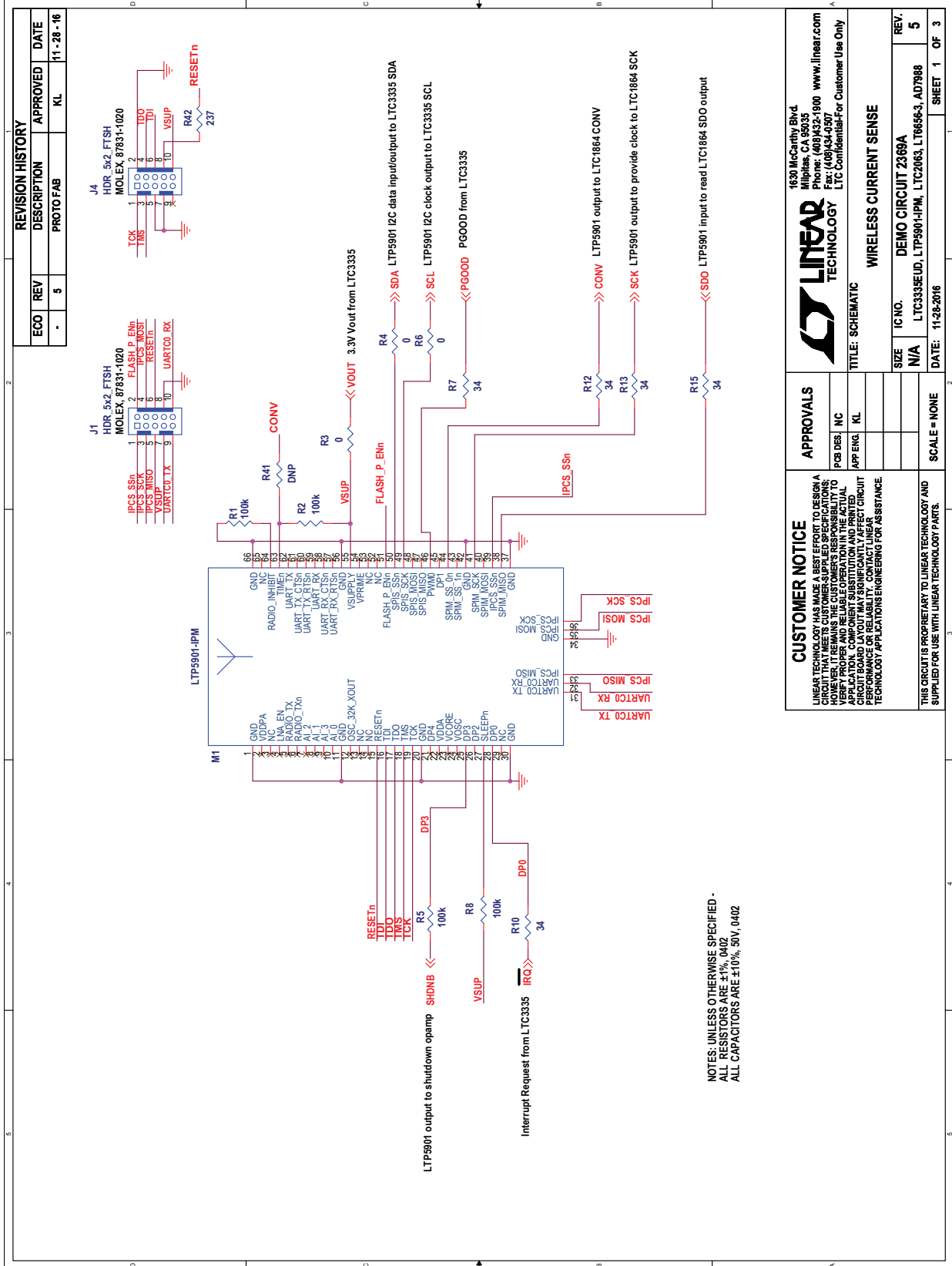

REVISION HISTORY

ECO	REV	DESCRIPTION	APPROVED	DATE
-	5	PROTO FAB	KL	11-28-16

LINER TECHNOLOGY
 1630 McCarthy Blvd.
 Milpitas, CA 95035
 Phone: (408)432-1900 www.linear.com
 Fax: (408)434-0907
 LTC Confidential-For Customer Use Only

APPROVALS

JOB DES	NC
APP ENG	KL

TITLE: SCHEMATIC
 WIRELESS CURRENT SENSE

SIZE	IC NO.	REV.
N/A	LTC3333REUD, LTP5901-IPM, LTC2063, L76656-3, AD7988	5

DATE: 11-25-2016
 SCALE = NONE
 SHEET 1 OF 3

CUSTOMER NOTICE
 LINER TECHNOLOGY HAS MADE A BEST EFFORT TO DESIGN A BOARD THAT WILL BE FUNCTIONAL AND RELIABLE. HOWEVER, IT REMAINS THE CUSTOMER'S RESPONSIBILITY TO VERIFY PROPER AND RELIABLE OPERATION IN THE ACTUAL APPLICATION. CUSTOMERS MUST CONSIDER THE EFFECTS OF BOARD LAYOUT, COMPONENT TOLERANCES, AND TEST CIRCUIT PERFORMANCE OR RELIABILITY. CONTACT LINER TECHNOLOGY APPLICATIONS ENGINEERING FOR ASSISTANCE.

THIS CIRCUIT IS PROPRIETARY TO LINER TECHNOLOGY AND SUPPLIED FOR USE WITH LINER TECHNOLOGY PARTS.

NOTES: UNLESS OTHERWISE SPECIFIED -
 ALL RESISTORS ARE ±1%, 0402
 ALL CAPACITORS ARE ±10%, 50V, 0402

DEMO MANUAL DC2369A

SCHEMATIC DIAGRAM

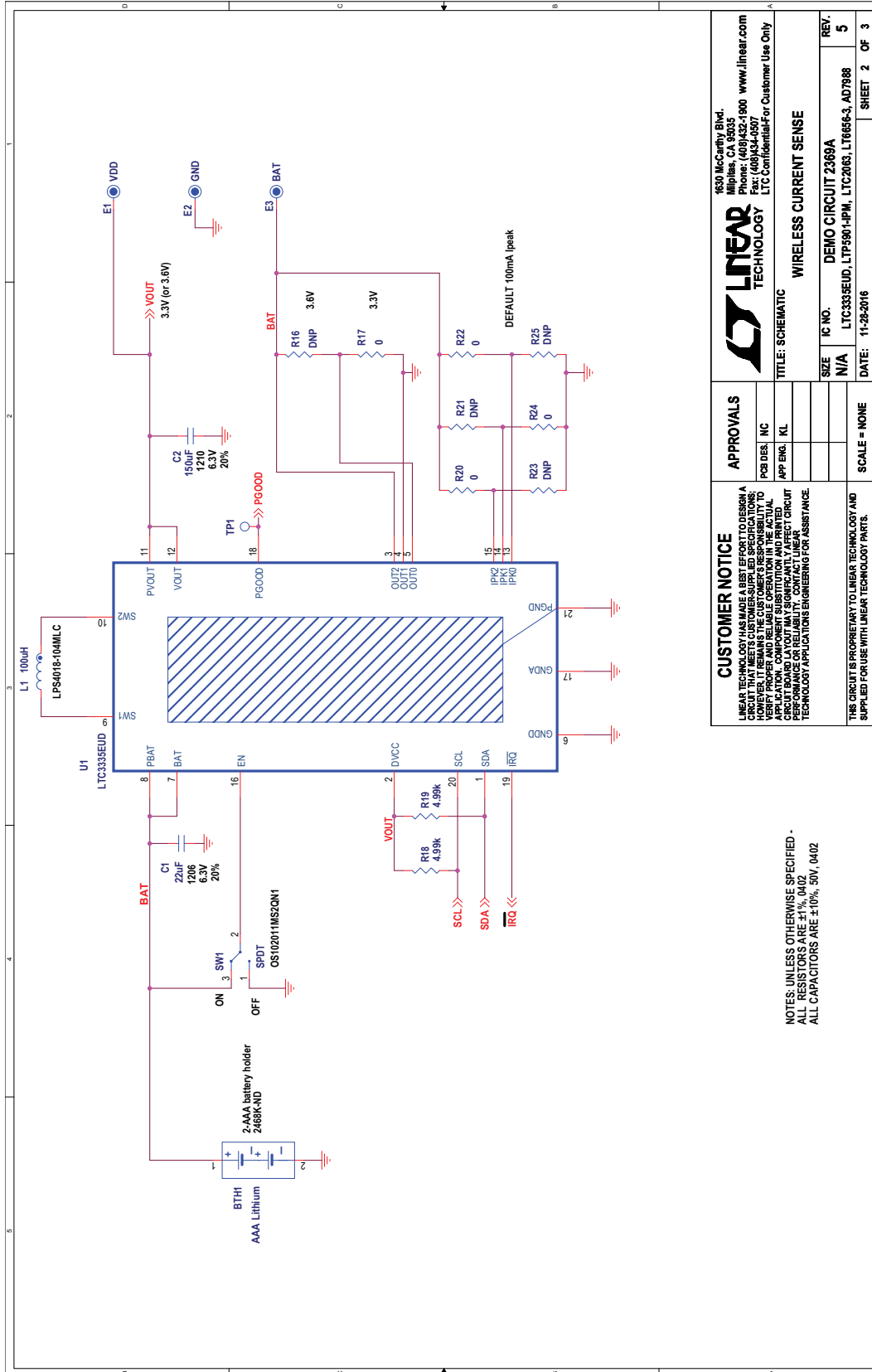

SCHEMATIC DIAGRAM

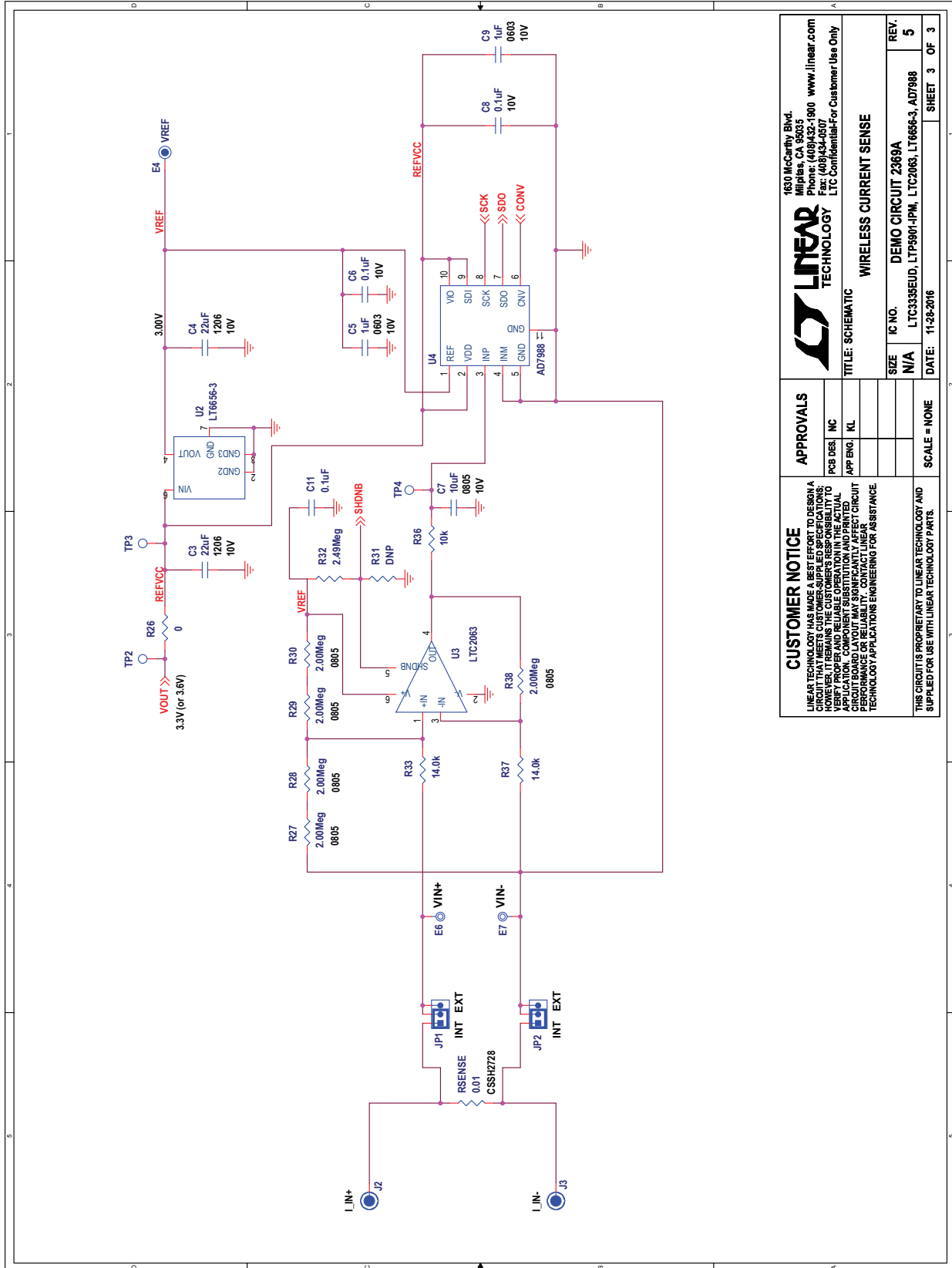

CUSTOMER NOTICE
 LINEAR TECHNOLOGY HAS MADE A BEST EFFORT TO DESIGN A CIRCUIT THAT MEETS CUSTOMER-SUPPLIED SPECIFICATIONS; HOWEVER, IT REMAINS THE CUSTOMER'S RESPONSIBILITY TO VERIFY THE DESIGN FOR ALL APPLICATIONS. COMPONENT SUBSTITUTION AND PRINTED CIRCUIT BOARD LAYOUT MAY SIGNIFICANTLY AFFECT CIRCUIT PERFORMANCE. CONTACT LINEAR TECHNOLOGY FOR ASSISTANCE TECHNOLOGY APPLICATIONS ENGINEERING FOR ASSISTANCE

APPROVALS

PCB DES.	NC
APP ENG.	KL

LINEAR TECHNOLOGY
 1630 McCarthy Blvd.
 Milpitas, CA 95035
 Phone: (408)322-1900 www.linear.com
 Fax: (408)324-0507
 LTC Confidential-For Customer Use Only

WIRELESS CURRENT SENSE

IC NO.	DEMO CIRCUIT 2369A	REV.
SIZE	N/A	5
DATE:	LTC3335EUD, LTP9801-PM, LTC2063, LT1665-3, AD7988	SHEET 3 OF 3

DEMO MANUAL DC2369A

DEMONSTRATION BOARD IMPORTANT NOTICE

Linear Technology Corporation (LTC) provides the enclosed product(s) under the following **AS IS** conditions:

This demonstration board (DEMO BOARD) kit being sold or provided by Linear Technology is intended for use for **ENGINEERING DEVELOPMENT OR EVALUATION PURPOSES ONLY** and is not provided by LTC for commercial use. As such, the DEMO BOARD herein may not be complete in terms of required design-, marketing-, and/or manufacturing-related protective considerations, including but not limited to product safety measures typically found in finished commercial goods. As a prototype, this product does not fall within the scope of the European Union directive on electromagnetic compatibility and therefore may or may not meet the technical requirements of the directive, or other regulations.

If this evaluation kit does not meet the specifications recited in the DEMO BOARD manual the kit may be returned within 30 days from the date of delivery for a full refund. **THE FOREGOING WARRANTY IS THE EXCLUSIVE WARRANTY MADE BY THE SELLER TO BUYER AND IS IN LIEU OF ALL OTHER WARRANTIES, EXPRESSED, IMPLIED, OR STATUTORY, INCLUDING ANY WARRANTY OF MERCHANTABILITY OR FITNESS FOR ANY PARTICULAR PURPOSE. EXCEPT TO THE EXTENT OF THIS INDEMNITY, NEITHER PARTY SHALL BE LIABLE TO THE OTHER FOR ANY INDIRECT, SPECIAL, INCIDENTAL, OR CONSEQUENTIAL DAMAGES.**

The user assumes all responsibility and liability for proper and safe handling of the goods. Further, the user releases LTC from all claims arising from the handling or use of the goods. Due to the open construction of the product, it is the user's responsibility to take any and all appropriate precautions with regard to electrostatic discharge. Also be aware that the products herein may not be regulatory compliant or agency certified (FCC, UL, CE, etc.).

No License is granted under any patent right or other intellectual property whatsoever. **LTC assumes no liability for applications assistance, customer product design, software performance, or infringement of patents or any other intellectual property rights of any kind.**

LTC currently services a variety of customers for products around the world, and therefore this transaction **is not exclusive**.

Please read the DEMO BOARD manual prior to handling the product. Persons handling this product must have electronics training and observe good laboratory practice standards. **Common sense is encouraged.**

This notice contains important safety information about temperatures and voltages. For further safety concerns, please contact a LTC application engineer.

Mailing Address:

Linear Technology
1630 McCarthy Blvd.
Milpitas, CA 95035

Copyright © 2004, Linear Technology Corporation

Mouser Electronics

Authorized Distributor

Click to View Pricing, Inventory, Delivery & Lifecycle Information:

[Analog Devices Inc.:](#)

[DC2369A](#)