

REV.	DATE	ECR NO.	DESCRIPTION
NC	08/18/98	-	INITIAL RELEASE
A	11/22/08	100059	INITIAL RELEASE

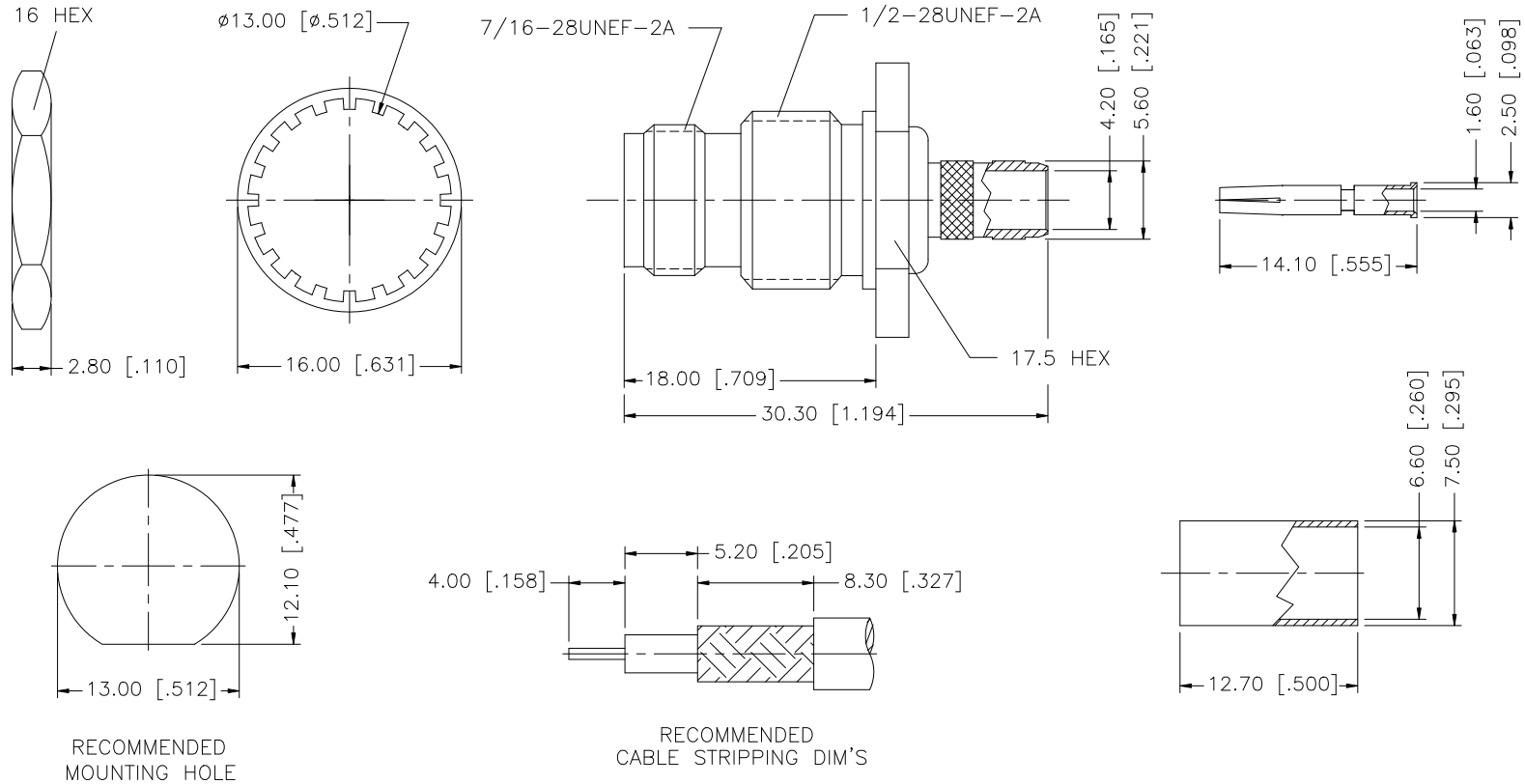

QTY	DESCRIPTION	MATERIAL	FINISH	QTY	UNLESS OTHERWISE SPECIFIED DIMENSIONS ARE IN MILLIMETERS. DIMENSIONS IN [] ARE IN INCHES AND FOR CUSTOMER REFERENCE ONLY.	APPROVALS	DATE	Amphenol Connex							
8	FERRULE	COPPER	NICKEL	1	UNLESS OTHERWISE SPECIFIED TOLERANCES FOR MILLIMETERS ARE: 0.5 - 8mm \pm 0.20mm 8 - 30mm \pm 0.40mm 30 - 120mm \pm 0.50mm	DRAWN	GRS	11/22/08	PART DESCRIPTION TNC BULKHEAD CRIMP JACK - LMR 240						
7	HEX NUT	BRASS	NICKEL	1		CHECKED									
6	LOCK WASHER	BRASS	NICKEL	1		ISSUED									
5	GASKET	SILICONE	RED	1		SHEET	1 OF 1								
4	CONTACT PIN	PHOS. BRONZE	GOLD	1	UNLESS OTHERWISE SPECIFIED TOLERANCES FOR INCHES ARE: .020 - .315 \pm 0.007" .315 - 1.180 \pm 0.015" 1.180 - 4.724 \pm 0.020"	PART NO.		122415							
3	INSULATOR	PTFE	NATURAL	1		DWG. NO.		122415.DWG		REV.	A	SIZE	A	SCALE	NA
2	BODY	BRASS	NICKEL	1	DO NOT SCALE DRAWING	CAD FILE		C:/122/122415.DWG							
1	HOUSING	BRASS	NICKEL	1											

Mouser Electronics

Authorized Distributor

Click to View Pricing, Inventory, Delivery & Lifecycle Information:

[Amphenol:](#)

[122415](#)