

DATE	DESCRIPTION	REV.
9.18.20	CHANGE AS PER ECN 20-083 WAS 700 PCS PER 13" REEL	A

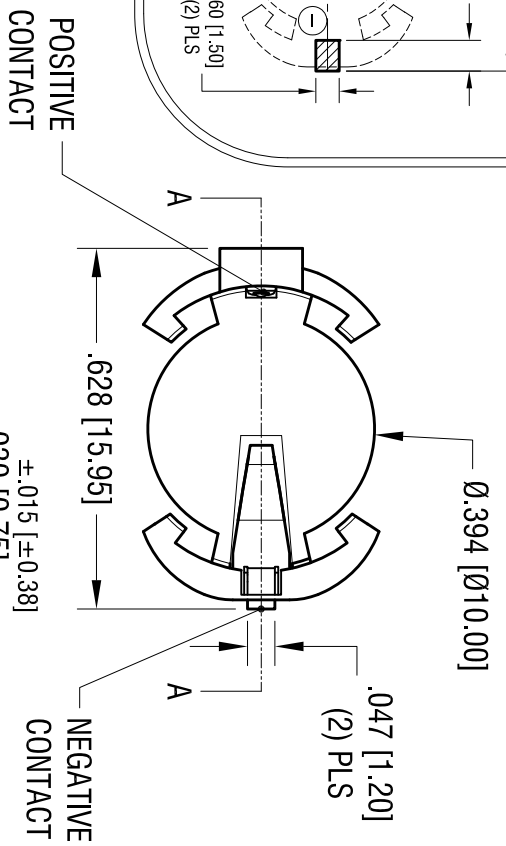

ACTUAL SIZE

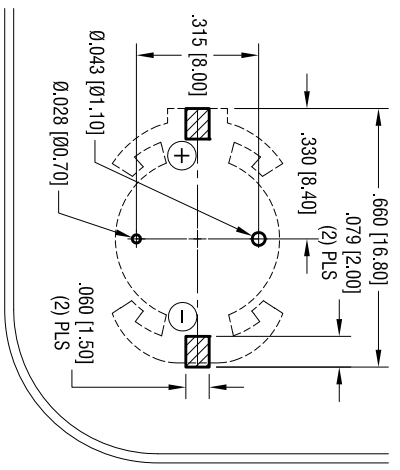
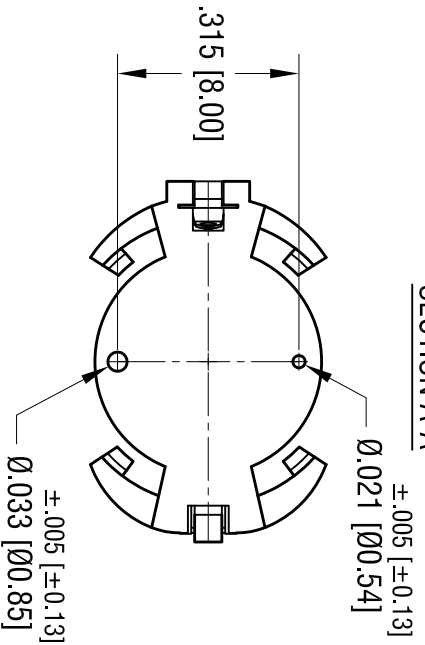
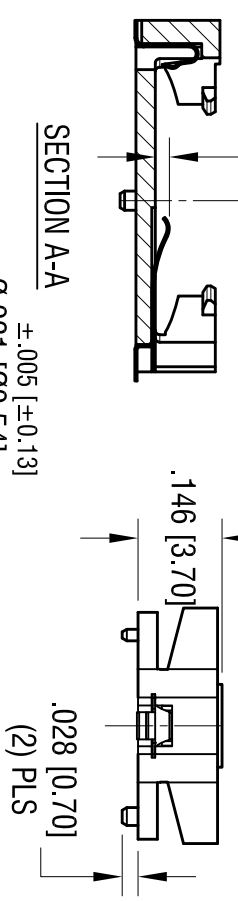

NOTES:
TAPE AND REEL SPECIFICATIONS:
1. TAPE:
MATERIAL - ALL CONDUCTIVE POLYSTYRENE CARRIER
ANSI/EIA-481 STANDARD
2. REEL:
15.0 [380.8] DIA. 1020 PIECES OF
PART NO. 1072 PER REEL.

HOLDER SPECIFICATIONS:
1. HOUSING: MAT'L- PLASTIC PA9T, BLACK
2. CONTACTS: MAT'L- PHOSPHOR BRONZE
FINISH: CONTACT AREA- GOLD FLASH
SOLDER AREA- MATTE TIN PLATE

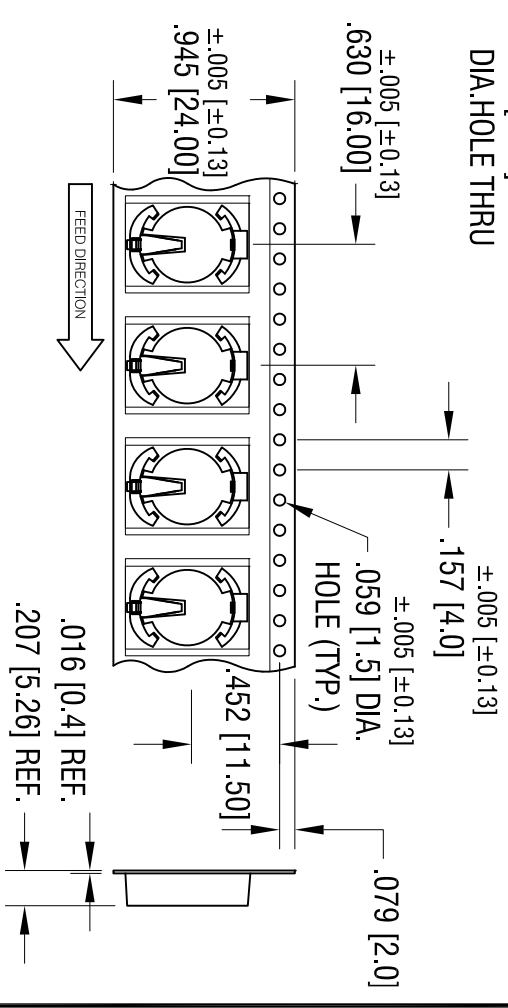
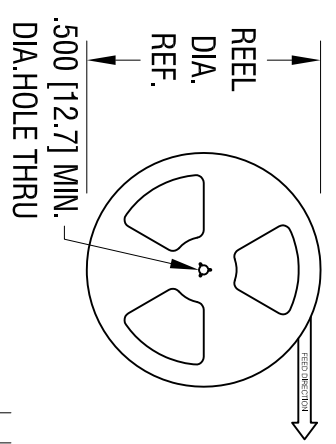

KEYSTONE ELECTRONICS CORP.

www.keystone.com • NEW HYDE PARK, NY 11040 • Tel (516) 328-7500

PART NAME: BATTERY HOLDER CR1220 / 1225

MATERIAL: AS NOTED

FINISH: AS NOTED

TOLERANCES	INCH	[MM]	CODE	DWG NO.
DECIMAL	± .010	[± 0.25]	C	
ANGULAR	± 1°			

THIS DOCUMENT IS THE PROPERTY OF KEYSTONE ELECTRONICS CORP. AND SHALL NOT BE REPRODUCED, DISTRIBUTED OR USED AS A BASIS FOR MANUFACTURE WITHOUT PRIOR WRITTEN PERMISSION FROM KEYSTONE ELECTRONICS CORP.

1072TR

Mouser Electronics

Authorized Distributor

Click to View Pricing, Inventory, Delivery & Lifecycle Information:

[Keystone Electronics:](#)

[1072TR](#)