

MAX25430A Evaluation Kit

Evaluates: MAX25430

General Description

The MAX25430 EVKIT and collateral provides a convenient platform to the design engineer for rapid evaluation with reduced test and firmware-development time.

The MAX25430A evaluation kit (EV kit) demonstrates the MAX25430A automotive-grade buck-boost controller capable of driving up to 5.0A, Legacy USB Charging support and USB Type-C™ protection for USB host or DFP applications.

The MAX25430A provides CC signal passthrough protection for the Cypress CCG3PA USB-PD controller.

The integrated USB Type-C protection switches provide automotive system-level ESD and 24V short-circuit protection for D+, D-, CC1, CC2, and CC lines when used as VCONN supply. The device also supports legacy USB 2.0 charging modes including BC1.2, Apple® 2.4A, Apple CarPlay®, Apple MFi and USB On-The-Go (OTG).

The register set can be reviewed using the Maxim Feather Board I²C to USB adapter, and the MAX2543x Graphical User Interface (GUI). Please contact the factory for more details.

The MAX25430 offers a factory option that includes intelligent detection and protection to avoid high short-circuit currents flowing from the car battery through the cable shield to ground during fault events, preventing car module damage. To evaluate, refer to the Ordering Information table in the MAX25430 datasheet and order the G-suffix sample from the factory. Once received, replace on the EV Kit and unsolder the bypass short around MOSFET (Q6).

[Ordering Information](#) appears at end of data sheet.

Benefits and Features

- 100W USB-PD REV3.0 Source Charger Solution using a Cypress PD Controller
- Legacy USB 2.0 Charging Support—Meets MFi R3x
- Register Set Accessible with Feather Board and GUI
- Test Points Available for Signal and Converter Analysis
- EV Kit is Ready for Factory IC Option with Customer Cable Shield Short-to-Battery Protection
- Proven PCB Layout
- Fully Assembled and Tested

Quick Start

The following procedure demonstrates the MAX25430A's charging functionality. The register set and GUI are described in the detailed description section.

EV Kit Content

- MAX25430_EVKIT_P3_00 board is referred to as MAX25430A EV Kit Board
- MAXPD_CY01_APPS_A board is referred to as PD Controller Board
- MAXPD_FTTHR_APPS_B board is referred to as Feather Board
- 6ft USB Type-C 5A Cable

Required Equipment

- MAX25430A EV Kit Board
- PD Controller Board
- 6ft USB Type-C Cable
- 14V/10A DC Power Supply or car battery (V_{BAT})
- Digital voltmeter (DVM)
- Device with Type-C port for charging

Initial Setup

The EV kit is fully assembled and tested. Follow the steps below to set up the board for evaluation.

- 1) Verify the jumper settings on the MAX25430A EV Kit Board match the settings in the tables below.

MAX25430A EV KIT BOARD JUMPER SETTINGS

OPEN, NO JUMPER	SHORT PINS 1 AND 2	SHORT PINS 2 AND 3
J2, J8, J9, J13, J15	J6, J7, J12, J14, J34	J1

- 2) Verify the I²C address switch (SW1) match the settings in the tables and images in the quick-start guide.

I²C ADDRESS SWITCH SETTINGS

SWITCH #1	SWITCH #2	SWITCH #3	SWITCH #4
ON	OFF	OFF	OFF

- 3) Verify the jumper settings on the PD Controller Board match the settings in the tables

PD CONTROLLER BOARD JUMPER SETTINGS

OPEN, NO JUMPER	SHORT PINS 1 AND 2	SHORT PINS 2 AND 3
J5, J6, J7, J11	J8, J9, J10	J2

- 4) Push the two boards together at J3 (40-pin header) as shown in the Initial EV kit setup below, [Figure 1](#).
- 5) Set the V_{BAT} power supply to 14V output, 5A current limit. Turn the output off. Connect the negative lead to the GND2 test loop on MAX25430A EV Kit Board. Connect positive lead to VBAT_FLT test loop on the MAX25430A EV Kit Board.
- 6) Connect the DMM positive lead to the HVBUS test loop on the MAX25430A EV Kit Board and connect the negative lead to the GND4 test loop on the MAX25430A EV Kit Board. Set for the DMM for voltage measurement.
- 7) Turn the V_{BAT} power supply output on.
- 8) Verify there is 0V on DMM.
- 9) Connect a USB Type-C device such as a laptop or mobile phone that can consume power over a Type-C port to J37 of the MAX25430A EV Kit Board.
- 10) Measure the V_{BUS} to ensure 5V, 9V, 15V, or 20V is being applied to the device.

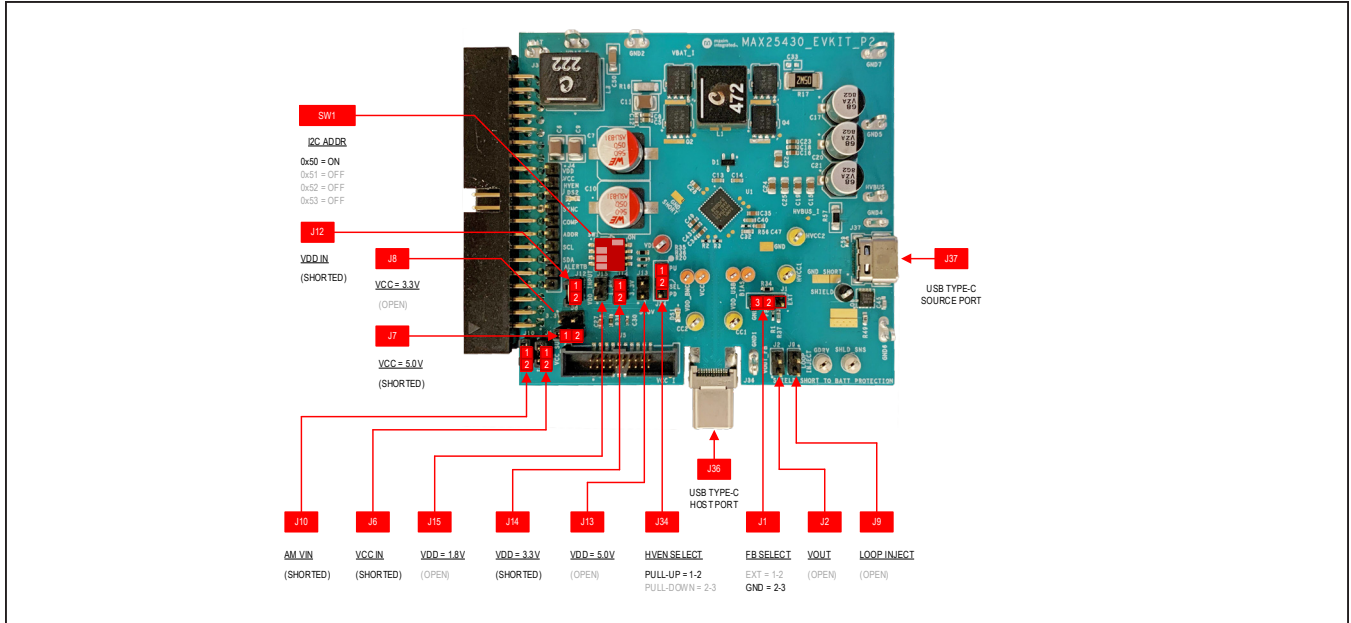

Figure 1 MAX25430 A EV Kit Board Jumper Positions

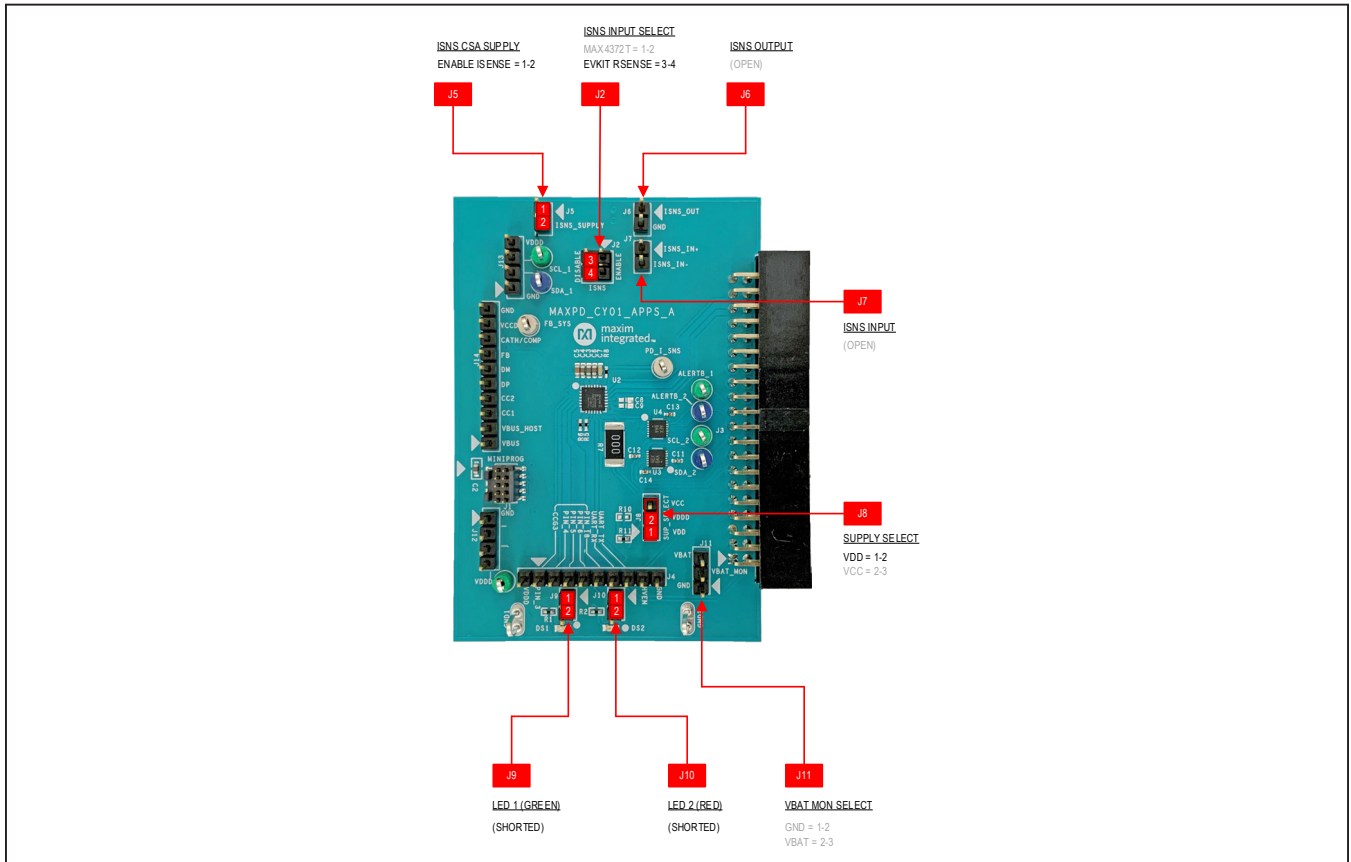

Figure 2 PD Controller Board Jumper Positions

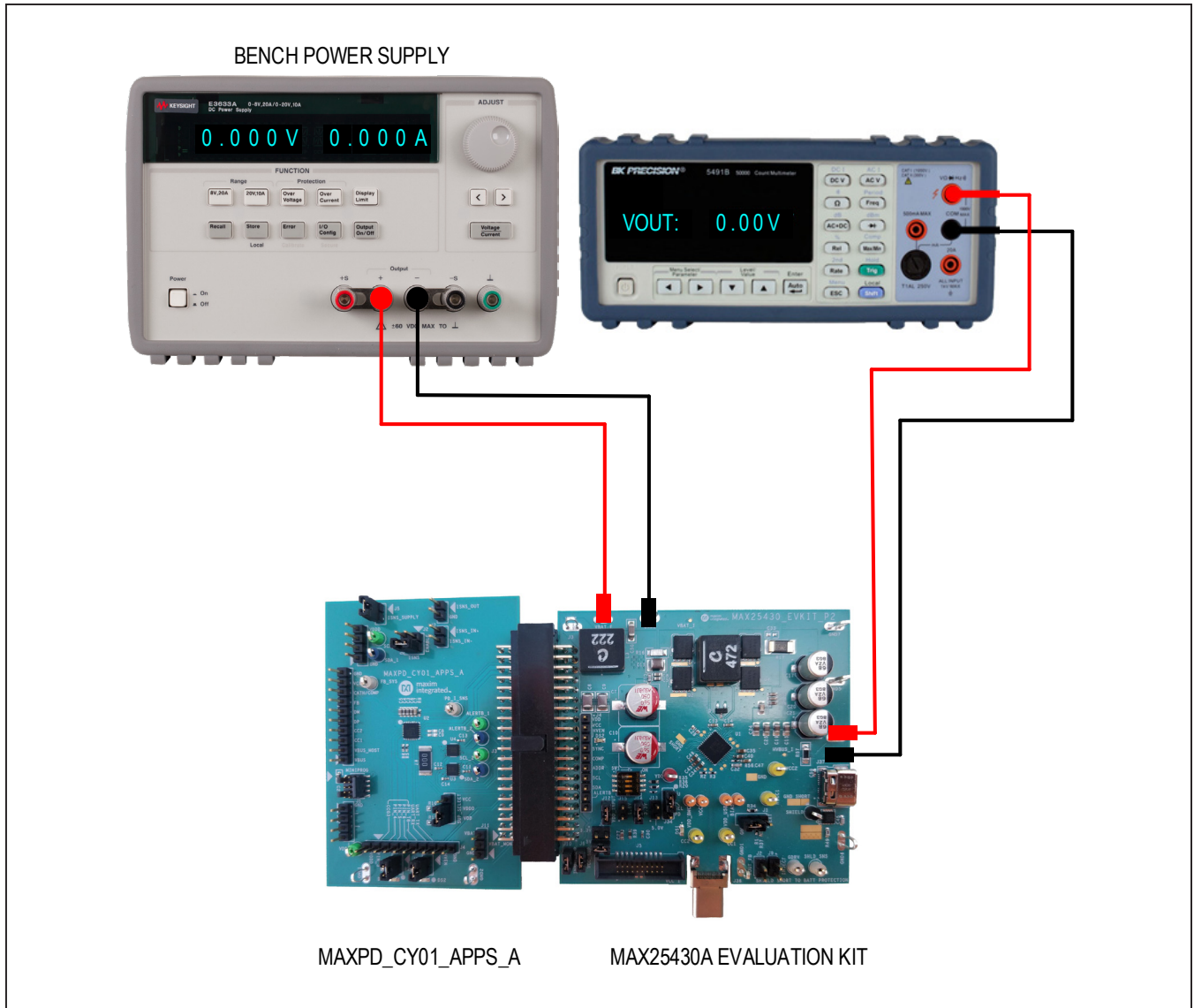

Figure 3 Initial EV Kit Setup

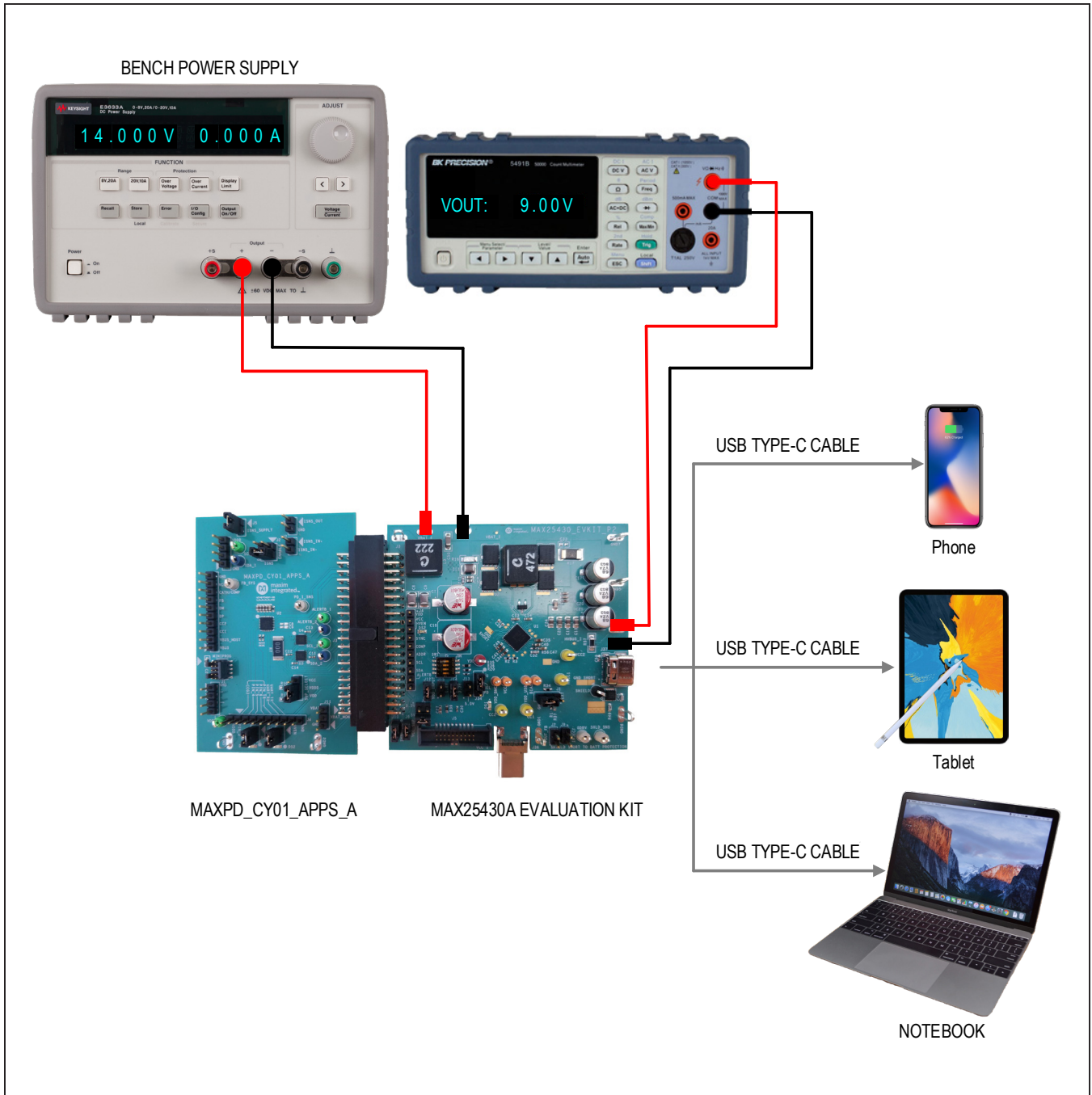

Figure 4 Powered EV Kit with Attached Device

Detailed Description

The MAX25430A EV Kit Board includes the MAX25430_EVKIT_P3, MAXPD_CY01_APPS_A (PD Controller Board), MAXPD_FTHR_APPS_B (Feather Board), and 6ft USB Type-C Cable. The PD Controller board connected to the MAX25430_EVKIT_P3 allows charging out of the box. The Feather Board connected to the MAX25430_EVKIT_P3 and used with the GUI allows register map reads and writes.

Please contact the factory for use of the Feather Board and GUI interface.

Jumpers and Configuration

The switch SW1 allows the user to set the I²C Address. Only one switch should be in the ON position at a single time.

[Table 2](#) shows jumper positions and descriptions.

[Table 3](#) shows test points and descriptions.

[Table 4](#) shows LEDs and descriptions.

Table 1. External Switch

SW1 PIN	POSITION	DESCRIPTION
1	0	Switch open
	ON	ADDR connected to ground setting the I ² C address to 0x50
2	0	Switch open
	ON	ADDR connected to an 8.87kΩ to ground setting the I ² C address to 0x51
3	0	Switch open
	ON	ADDR connected to a 15.8kΩ to ground setting the I ² C address to 0x52
4	0	Switch open
	ON	ADDR connected to a 10kΩ to BIAS setting the I ² C address to 0x53

Table 2. Jumper Descriptions

JUMPER	POSITION	DESCRIPTION
J1	1-2	Feedback network connected to pin 30 of the MAX25430. Do not connect Jumper J1 to position 1-2.
	2-3*	Connects pin 30 of the MAX25430 to ground.
J2	Open*	Always leave open.
J6	Shunted*	Shunt to provide V _{BAT} to the MAX20075 (U6). Provides VCONN supply.
J7	Shunted*	Shunting connects the feedback network setting 5V on VCC_OUT. Leave open if using jumper J8.
J8	Open*	Shunting connects the feedback network setting 3.3V on VCC_OUT. Leave open if using jumper J7.
J9	Open	Always leave open.
J10	Shorted*	Provides power to the Active Metering block.
J12	Shunted*	Shunt to provide VBAT to the MAX20075 (U7). Provides VDD_OUT.
J13	Open*	Shunting connects the feedback network setting 5V on VDD_OUT. Leave open if using jumper J14 or J15.
J14	Shunted*	Shunting connects the feedback network setting 3.3V on VDD_OUT. Leave open if using jumper J13 or J15.
J15	Open*	Shunting connects the feedback network setting 1.8V on VDD_OUT. Leave open if using jumper J13 or J14.
J34	1-2*	Connects HVEN to a 10kΩ to V _{BAT} , enabling the IC.
	2-3	Connects HVEN to a 10kΩ to Ground, disabling the IC.

*Default position.

Table 3. Test Points

TEST POINT	DESCRIPTION
VBAT_FLT	Main Battery Input. Connect a 4.5V to 36V supply
VBAT	Main Battery Input, bypassing the reverse battery and input EMI filter.
HVBUS	VBUS Output of the MAX25430A
VDD	Pin 9 of the MAX25430A, VDD_IO input. This rail also provides power to the PD Controller.
VDD_BMC	Used with the MAX25430B versions. Pin 13 of the MAX25430, internal 1.125V regulated supply output.
VCC	Pin 16 of the MAX25430A, VCONN input
VDD_USB	Pin 17 of the MAX25430A, regulated output of the internal 3.3V regulator.
BIAS	Pin 29 of the MAX25430A, regulated output of the internal 5V regulator.
HVCC1	Pin 25 of the MAX25430A, CC line on the device side.
HVCC2	Pin 24 of the MAX25430A, CC line on the device side.
CC1	Pin 14 of the MAX25430A, CC line on the host side.
CC2	Pin 15 of the MAX25430A, CC line on the host side.
SHLD_SNS	Pin 7 of the MAX25430A, shield Short-to-Battery Protection Sense pin.
GDRV	Pin 8 of the MAX25430A, shield MOSFET Gate drive output.

Table 4. LEDs

LED	DESCRIPTION
DS1	Indicates power good for the VCONN supply
DS2	Indicates power good for the VDD supply.

Procedure to Measure Internal Power Supplies

- 1) Repeat steps 1 through 10 in the quick-start guide.
- 2) Connect the DMM positive lead to the BIAS test point on the MAX25430A EV Kit Board. The DMM should read between 4.7V and 5.4V.
- 3) Connect the DMM positive lead to the VDD_USB test point on the MAX25430A EV Kit Board. The DMM should read between 3.0V and 3.6V.
- 4) Connect the DMM positive lead to the VDD_BMC test point on the MAX25430A EV Kit Board. The DMM should read 0V.
- 5) Connect the DMM positive lead to the VCC test point on the MAX25430A EV Kit Board. The DMM should read between 4.7V and 5.4V.

Basic Functionality

Connect a battery voltage supply from 4.5V to 36V to the VBAT_F and GND test loops. Setting the HVEN switch to ON pulls the HVEN pin to V_{BAT} and enables the device. The V_{BUS} powers only after a valid device attach has occurred.

The on-board MAX20075 power supplies make testing VCONN and I²C communication easy for the user. Contact the factory for an optimized BOM without external power supplies.

Fault Diagnostics

The MAX25430A Maxim Auto-Shield protects the power delivery solution against most faults. See the MAX25430 datasheet for all conditions that can trigger a FAULT event, action, and recovery. The PD Controller Board is notified using the $\overline{\text{ALERT}}$ pin.

Buck-Boost Controller Operation

To observe the Buck-Boost Controller switching waveforms, copper pads are provided at both switching nodes. The LX1 waveform can be observed by measuring at the two pads near the Q2 MOSFET. The LX2 waveform can be observed by measuring at the two pads near the Q4 MOSFET.

The controller can be turned on with device connection, USB-PD power meter, or Feather Board and GUI.

VCONN

The MAX25430 has built-in VCONN switches that provide connection from VCC to HVCC when a correct R_A is provided on the HVCC line. This is accomplished with the connection of the e-marked cable provided in this kit, forcing R_A on the HVCC pin, or using the Feather Board and GUI. Details on interfacing with the register set is covered in the MAX25430 datasheet.

The internal VCONN switches protect against overcurrent, undervoltage, reverse overvoltage, and short-to-ground. Details on the event, reporting, debounce, action, and recovery are described in the MAX25430 datasheet.

The fast protection response to short-to-ground event can be observed by using an oscilloscope to monitor HVCC1, CC1, and VCC. Connect a 1k Ω resistor from HVCC1 to ground and a 5.1k Ω from HVCC2 to GND. Using a short wire, connect HVCC1 to ground and observe a very minimal drop on VCC voltage and fast disconnect of HVCC1 and CC1 from the VCC voltage.

Data Switch Bandwidth

USB Type-C connectors J36 and J37 can be used to test data bandwidth. Connector J37 is on the device side and connects to the HVD+, HVD- of the MAX25430. Connector J36 is on the host side and connects to the MAX25430 D+, D- pins.

The MAX25430A EV Kit Board is configured for Auto-DCP and will require the Feather Board and GUI to adjust to High-Speed Passthrough. Before applying the test signal, remove resistors R2 and R3.

The switches are also protected against shorting to battery, and VBUS with HVD Overvoltage fault discussed in the MAX25430 datasheet.

HVD+, HVD- also have integrated ± 15 kV Air, ± 8 kV Contact ISO 10605 and IEC 61000-4-2 ESD Protection.

CC Line Protection

The CC line switches are protected against shorting to battery, and VBUS with HCC Overvoltage fault discussed in the MAX25430 datasheet.

HVCC1, HVCC2 also have integrated ± 15 kV Air, ± 8 kV Contact ISO 10605 and IEC 61000-4-2 ESD Protection.

Shield-Short-to-Battery

USB shield GND short to car battery can occur when a customer's portable device cable is connected to the downstream receptacle, and the far end of this cable falls in to the 12V cigarette lighter receptacle and contacts the 12V center terminal. This condition results in a damaging amount of current flow if there is insufficient response time by the cigarette lighter fuse.

The MAX25430 offers advanced integrated protection for cable Shield-Short-to-Battery faults to prevent cable, passenger device, and car module damage. The solution uses fast detection of cable shield overcurrent, fast turn-off of external protection switch, safe dissipation of inrush energy, fault reporting, and auto-retry for fault removal.

To evaluate the Shield Short-to-Battery protection feature of the MAX25430, the correct option should be ordered. The MAX25430 datasheet Ordering Information section provides the part number and suffix that offer this protection feature.

Once ordered and received, replace the IC at U1 and remove the short on the copper pads labeled GND SHORT near the SHIELD test point and connector J37. Short location shown in [Figure 5](#).

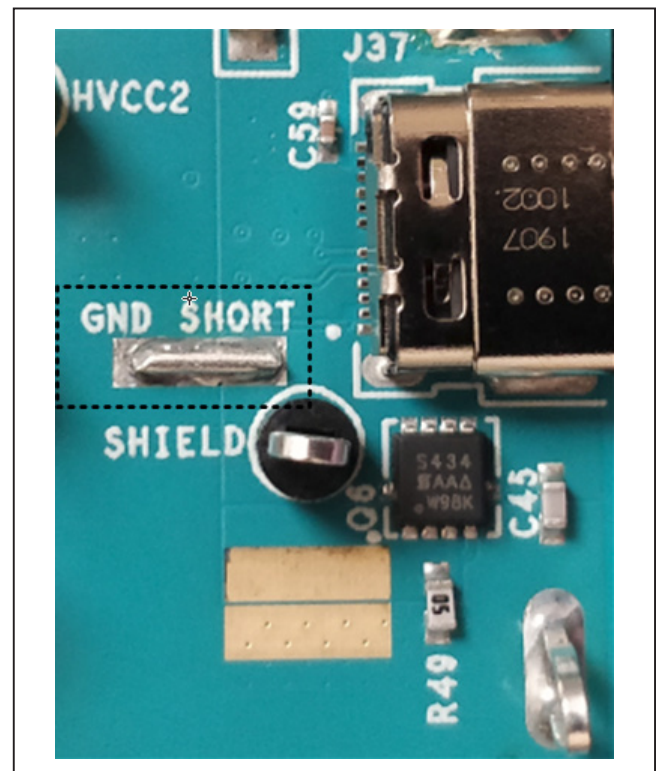

Figure 5 GND SHORT Location

Vendor-Defined Register Initialization

Vendor-Defined Register Configuration after initialization is in [Table 5](#).

References

[Table 6](#) shows the reference specifications, their locations, and the common names they are referred to in this document.

Table 5. Vendor Defined Register Configuration

ADDRESS	NAME	BIT	INITIALIZATION VALUE
0x80	PWR_OUT_CONTROL	VOUT_ILIM	4A (0x1)
		VOUT_SEL	5V (0x0)
0x81	CABLE_COMP_CONTROL	GAIN	40mΩ (0x05)
0x83	BUCK_BOOST_SETUP	SLP	400mV (0x011)
		FSW	400kHz (0x10)
		SYNC_DIR	Input (0x1)
		Spread Spectrum	±9% (0x11)
0x84	WATCHDOG_SETUP	WD_TIMEOUT	1 second (0x00)
0x85	AUTO_SHIELD_SETUP	RETRY_TIMER	16ms (0x11)
0x86	AUTO_CDP_DCP_SETUP	AUTO_CDP_DCP_MODE	Auto-DCP / Apple 2.4A (0x10)
0x87	IN_THRESH	IN_UV_THRESH	4.5V (0x0)
0x88	VCONN_THRESH	VCONN_OCP_SEL	250 mA (0x0)
		VCONN_IN_UV_THRESH	4.65V (0x7)
0x89	VBUS_THRESH	VBUS_OV_THRESH	+12.5 % (0x3)
		VBUS_UV_THRESH	-12.5% (0x3)
0x8A	AUTO_SHIELD_STATUS_MASK	SHIELDING_MASK	Included in VNDR_ALERT (mask) (0x1)
		VCONN_IN_UV_MASK	Not included in VNDR_ALERT (0x0)
		IN_OC_MASK	Not included in VNDR_ALERT (0x0)
		VDD_USB_UV_MASK	Not included in VNDR_ALERT (0x0)
		VBUS_UV_MASK	Not included in VNDR_ALERT (0x0)

Table 6. Reference

REFERRED TO IN THIS DOCUMENT	TITLE	LOCATION
USB-PD REV3.0	The Universal Serial Bus Power Delivery Specification Revision 3.0, Version 1.2 June 21, 2018	http://www.usb.org
MAX25430 Data Sheet	Automotive 100W USB-PD Buck-Boost Port Controller and Protector 19-100826 Revision 0, August 2020	https://www.maximintegrated.com/en.html

Ordering Information

PART	TYPE
MAX25430AEVKIT#	EV Kit

#Denotes RoHS compliant.

MAX25430A EV Kit Bill of Materials

ITEM	REF_DES	DN/DNP	QTY	MFG PART #	MANUFACTURER	VALUE	DESCRIPTION	COMMENTS
1	BIAS, VCC, VDD_BMC, VDD_USB	-	4	5003	KEYSTONE	N/A	TEST POINT; PIN DIA=0.1IN; TOTAL LENGTH=0.3IN; BOARD HOLE=0.04IN; ORANGE; PHOSPHOR BRONZE WIRE SILVER PLATE FINISH;	
2	BUMP1-BUMP4	-	4	SJ-5003(BLACK)	3M ELECTRONIC SOLUTIONS DIVISION	SJ-5003(BLACK)	BUMPER; BLACK-HEMISPHERICAL SHAPE EVKIT EH0231; 0.44D/0.2BH; RESILIENT ELASTOMER POLYURETHANE	
3	C1, C3, C4, C36	-	4	GRM32ER71H106KA12; CL32B106KBJNN; UMJ325KB7106KMH; 12105C106K4Z2A	MURATA;SAMSUNG ELECTRONICS; TAIYO YU	10UF	CAPACITOR; SMT (1210); CERAMIC CHIP; 10UF; 50V; TOL=10%; TG=-55 DEGC TO +125 DEGC; TC=X7R	
4	C2, C27	-	2	C1608X7R1V105K080AC	TDK	1UF	CAPACITOR; SMT (0603); CERAMIC CHIP; 1UF; 35V; TOL=10%; TG=-55 DEGC TO +125 DEGC; TC=X7R	
5	C5	-	1	UMK107BJ105KA; C1608X5R1H105K080AB; CL10A105KB8NNN; GRM188R61H105KAAL	TAIYO YUDEN;TDK;SAMSUNG;MURATA	1UF	CAPACITOR; SMT (0603); CERAMIC CHIP; 1UF; 50V; TOL=10%; MODEL= MK SERIES; TG=-55 DEGC TO +85 DEGC	
6	C6, C9, C11	-	3	C3225X7S1H106K250AB; CGA6P3X7S1H106K250AB; GCM32EC71H106K	TDK;TDK;MURATA	10UF	CAPACITOR; SMT (1210); CERAMIC CHIP; 10UF; 50V; TOL=10%; TG=-55 DEGC TO +125 DEGC; TC=X7S	
7	C7, C10	-	2	8.65081E+11	WURTH ELECTRONICS INC.	56UF	CAP. SMT (CASE_HA0); 56UF; 20%; 50V; ALUMINUM-ELECTROLYTIC	
8	C8, C13, C14, C40	-	4	C0603C104K5RAC; C1608X7R1H104K; ECJ-1VB1H104K; GRM188R71H104KA93; CGJ3E2X7R1H104K080AA; C1608X7R1H104K080AA; CL10B104KB8NNN; CL10B104KB8NFN; 06035C104KAT2A	KEMET;TDK;PANASONIC;MURATA;TDK; TDK;SAMSUNG.SAMSUNG;AVX	0.1UF	CAPACITOR; SMT (0603); CERAMIC CHIP; 0.1UF; 50V; TOL=10%; TG=-55 DEGC TO +125 DEGC; TC=X7R;	
9	C12	-	1	C1608C0G1H103J080AA; CGA3E2C0G1H103J080AD; GRM1885C1H103JA01	TDK;TDK;MURATA	0.01UF	CAPACITOR; SMT (0603); CERAMIC CHIP; 0.01UF; 50V; TOL=5%; TG=-55 DEGC TO +125 DEGC; TC=C0G	
10	C15, C19, C22, C24, C25	-	5	C2012X5R1V106K085AC	TDK	10UF	CAPACITOR; SMT (0805); CERAMIC CHIP; 10UF; 35V; TOL=10%; TG=-55 DEGC TO +85 DEGC; TC=X5R	
11	C16	-	1	CGA3E1X7R1V105K	TDK	1UF	CAPACITOR; SMT (0603); CERAMIC CHIP; 1UF; 35V; TOL=10%; TG=-55 DEGC TO +125 DEGC; TC=X7R; AUTO;	
12	C17, C20, C21	-	3	EEH-ZA1V680XP	PANASONIC	68UF	CAP. SMT (CASE_D8); 68UF; 20%; 35V; ALUMINUM-ELECTROLYTIC	
13	C18, C23	-	2	GMK107B7104KAH	TAIYO YUDEN	0.1UF	CAPACITOR; SMT (0603); CERAMIC CHIP; 0.1UF; 35V; TOL=10%; TG=-55 DEGC TO +125 DEGC; TC=X7R	
14	C29, C37	-	2	GRM31CR71H475KA12; GRJ31CR71H475KE11; GXM31CR71H475KA10; UMK316AB7475KL	MURATA;MURATA;MURATA; TAIYO YUDEN	4.7UF	CAPACITOR; SMT (1206); CERAMIC CHIP; 4.7UF; 50V; TOL=10%; MODEL=; TG=-55 DEGC TO +125 DEGC; TC=X7R	
15	C30, C38, C58, C59	-	4	C1005X7R1H104K050BB; GRM155R71H104KE14; C1005X7R1H104K050BE; UMK105B7104KV-FR	TDK;MURATA;TDK;TAIYO YUDEN	0.1UF	CAPACITOR; SMT (0402); CERAMIC CHIP; 0.1UF; 50V; TOL=10%; TG=-55 DEGC TO +125 DEGC; TC=X7R	
16	C31, C39	-	2	GRM32ER71E226KE15; CL32B226KAJNFN; CL32B226KAJNNW; T1MK325B7226KM	MURATA;SAMSUNG ELECTRO-MECHANICS;TA	22UF	CAPACITOR; SMT (1210); CERAMIC CHIP; 22UF; 25V; TOL=10%; TG=-55 DEGC TO +125 DEGC; TC=X7R	
17	C32	-	1	0603YC101KAT2A	AVX	100PF	CAPACITOR; SMT (0603); CERAMIC CHIP; 100PF; 16V; TOL=10%; TG=-55 DEGC TO +125 DEGC; TC=X7R	
18	C34, C49	-	2	C0603C105K4RAC; GRM188R71C105KA12; C1608X7R1C105K080AC; EMK107B7105KA; CGA3E1X7R1C105K080AC; 0603YC105KAT2A	KEMET;MURATA;TDK;TAIYO YUDEN; TDK;AVX	1UF	CAPACITOR; SMT (0603); CERAMIC CHIP; 1UF; 16V; TOL=10%; MODEL=; TG=-55 DEGC TO +125 DEGC; TC=X7R	
19	C35	-	1	GRM188Z71C475KE21	MURATA	4.7UF	CAPACITOR; SMT (0603); CERAMIC CHIP; 4.7UF ; 16V; TOL=10%; TG=-55 DEGC TO +125 DEGC; TC=X7R	
20	C41, C50	-	2	GRM31CR71H225KA88; UMK316B7225K	MURATA;TAIYO YUDEN	2.2UF	CAPACITOR; SMT (1206); CERAMIC CHIP; 2.2UF; 50V; TOL=10%	
21	C43	-	1	GRM188R61C106KAAL	MURATA	10UF	CAPACITOR; SMT (0603); CERAMIC CHIP; 10UF; 16V; TOL=10%; TG=-55 DEGC TO +85 DEGC; TC=X5R	
22	C44	-	1	C0603C101J1GAC; GRM1885C2A101JA01	KEMET;MURATA	100PF	CAPACITOR; SMT (0603); CERAMIC CHIP; 100PF; 100V; TOL=5%; MODEL=; TG=-55 DEGC TO +125 DEGC; TC=C0G	
23	C45	-	1	GRM1885C1H102JA01; C1608C0G1H102J080AA; GCM1885C1H102JA16	MURATA;TDK;MURATA	1000PF	CAPACITOR; SMT (0603); CERAMIC CHIP; 1000PF; 50V; TOL=5%; TG=-55 DEGC TO +125 DEGC	
24	C47	-	1	GRM188R71C123KA01	MURATA	0.012UF	CAPACITOR; SMT (0603); CERAMIC CHIP; 0.012UF; 16V; TOL=10%; MODEL=GRM SERIES; TG=-55 DEGC TO +125 DEGC; TC=X7R	
25	C51	-	1	GRM188R71C103KA01; ECJ-1VB1C10; CL10B103K08NNN; GCJ188R71C103KA01	MURATA;PANASONIC; SAMSUNG;MURATA	0.01UF	CAPACITOR; SMT (0603); CERAMIC CHIP; 0.01UF; 16V; TOL=10%; TG=-55 DEGC TO +125 DEG; TC=X7R	
26	C53, C55, C64	-	3	C1005X7R1C104K050BC; ATC530L104KT16; 0402YC104KAT2A; C0402X7R160-104KNE; CL05B104K05NNC; GRM155R71C104KA88; C1005X7R1C104K; CC0402KRX7R7BB104; EMK105B7104KV; CL05B104K05	TDK;AMERICAN TECHNICAL CERAMICS; AVX;VENKEL LTD.;SAMSUNG ELECTRONICS;MURATA;TDK;YAGEO PHICOMP;TAIYO YUDEN;SAMSUNG ELECTRONICS	0.1UF	CAPACITOR; SMT (0402); CERAMIC CHIP; 0.1UF; 16V; TOL=10%; TG=-55 DEGC TO +125 DEGC; TC=X7R	

MAX25430A EV Kit Bill of Materials (continued)

ITEM	REF_DES	DN/DNP	QTY	MFG PART #	MANUFACTURER	VALUE	DESCRIPTION	COMMENTS
27	C56, C57, C65	-	3	C0402C102K5RAC; GMC04X7R102K50NT; C0402X7R500-102K; GRM155R71H102KA01	KEMET;CAL-CHIP ELECTRONIC INC.; VENKEL LTD;MURATA	1000PF	CAPACITOR; SMT; 0402; CERAMIC; 1000pF; 50V; 10%; X7R; -55degC to + 125degC;	
28	C60, C61	-	2	C1608X7R1H224K080; GRM188R71H224KAC4	TDK;MURATA	0.22UF	CAPACITOR; SMT (0603); CERAMIC CHIP; 0.22UF; 50V; TOL=10%; TG=-55 DEGC TO +125 DEGC; TC=X7R	
29	CC1, CC2, HVCC1, HVCC2	-	4	5009	KEYSTONE	N/A	TEST POINT; PIN DIA=0.125IN; TOTAL LENGTH=0.35IN; BOARD HOLE=0.063IN; YELLOW; PHOSPHOR BRONZE WIRE SILVER PLATE FINISH;	
30	D1	-	1	BAT54A	FAIRCHILD SEMICONDUCTOR	BAT54A	DIODE; SCHOTTKY; PIV=30V; IF(MAX)=0.20A, PD=0.29W, SOT23, COMMON ANODE;	
31	D2	-	1	BZT52C10S-7-F	DIODES INCORPORATED	10V	DIODE; ZNR; SMT (SOD-323); VZ=10V; IZ=0.005A	
32	DS1, DS2	-	2	APT1608LZGCK	KINGBRIGHT	APT1608LZGCK	DIODE; LED; GREEN WATER CLEAR; GREEN; SMT (0603); VF=2.65V; IF=0.002A	
33	GDRV, SHLD_SNS	-	2	5007	KEYSTONE	N/A	TEST POINT; PIN DIA=0.125IN; TOTAL LENGTH=0.35IN; BOARD HOLE=0.063IN; WHITE; PHOSPHOR BRONZE WIRE SILVER PLATE FINISH;	
34	GND1, GND2, GND4-GND7, HVBUS, VBAT, VBAT_F	-	9	5020	KEYSTONE	MAXIMPAD	EVKIT PART - MAXIM PAD; TEST POINT; PIN DIA=0.084IN; TOTAL LENGTH=0.350IN; BOARD HOLE=0.040IN; NONE; PHOSPHOR BRONZE WIRE SILVER PLATE FINISH;	
35	J1, J34	-	2	TSW-103-23-G-S	SAMTEC	TSW-103-23-G-S	CONNECTOR; THROUGH HOLE; SINGLE ROW; STRAIGHT; 3PINS; -55 DEGC TO +125 DEGC	
36	J2, J6-J10, J12-J15	-	10	PCC02SAAN	SULLINS	PCC02SAAN	CONNECTOR; MALE; THROUGH HOLE; BREAKAWAY; STRAIGHT THROUGH; 2PINS; - 65 DEGC TO +125 DEGC	
37	J3	-	1	SBH11-PBPC-D20-RA-BK	SULLINS ELECTRONICS CORP	SBH11-PBPC-D20-RA-BK	CONNECTOR; MALE; THROUGH HOLE; HEADER CONNECTOR; RIGHT ANGLE; 40PINS	
38	J4	-	1	TSW-110-07-G-S	SAMTEC	TSW-110-07-G-S	CONNECTOR; MALE; THROUGH HOLE; 0.025 IN SQ POST HEADER; STRAIGHT; 10PINS	
39	J5	-	1	ESHF-110-01-L-D-SM-K	SAMTEC	ESHF-110-01-L-D-SM-K	CONNECTOR; MALE; SMT; SHROUDED AND EJECTOR IDC HEADER; STRAIGHT; 20PINS	
40	J37	-	1	2012670005	MOLEX	2012670005	CONNECTOR; FEMALE; SMT; USB TYPE C RECEPTACLE; RIGHT ANGLE; 24PINS	
41	L1	-	1	XAL1060-472ME	COILCRAFT	4.7UH	INDUCTOR; SMT; COMPOSITE; 4.7UH; 20%; 14A	
42	L2, L4	-	2	LQM21PZ4R7MGR	MURATA	4.7UH	INDUCTOR; SMT (0805); FERRITE; 4.7UH; 20%; 0.8A	
43	L3	-	1	XAL1060-222ME	COILCRAFT	2.2UH	INDUCTOR; SMT; COMPOSITE; 2.2UH; 20%; 20A	
44	L5	-	1	BLM31SN500S21	MURATA	50	INDUCTOR; SMT (1206); FERRITE-BEAD; 50 AT 100MHZ; TOL=12.50MHMS; 12A	
45	MISC1	-	1	FFSD-10-D-02.00-01-N	SAMTEC	FFSD-10-D-02.00-01-N	CABLE ASSEMBLY; IDC RIBBON CABLE ASSEMBLY; FEMALE-FEMALE; DOUBLE END; 0.05IN PITCH; 20 PINS	
46	Q1-Q4	-	4	NVMFSSC460NLAFT1G	ON SEMICONDUCTOR	NVMFSSC460NLAFT1G	TRAN; NCH; POWER MOSFET; SO-8FL; PD-(50W); I-(78A); V-(40V)	
47	Q5	-	1	FDWS9509L-F085	ON SEMICONDUCTOR	FDWS9509L-F085	TRAN; PCH; POWER-56; PD-(107W); I-(65A); V-(40V)	
48	Q6	-	1	SIS434DN-T1-GE3	VISHAY	SIS434DN-T1-GE3	TRAN; NCH; N-CHANNEL 40-V (D-S) MOSFET; POWERPAK1212-8; PD-(52W); I-(35A); V-(40V)	
49	R1-R3, R12, R15, R22, R23, R30	-	8	RC0402JR-070RL; CR0402-16W-000RJT	YAGEO PHYCOMP;VENKEL LTD.		RESISTOR; 0402; 0 OHM; 5%; JUMPER; 0.063W; THICK FILM	
50	R4, R8	-	2	CRCW040223K2FK	VISHAY DALE	23.2K	RESISTOR; 0402; 23.2K OHM; 1%; 100PPM; 0.063W; THICK FILM	
51	R5, R11	-	2	PF0603FRE710R01Z	YAGEO	0.01	RESISTOR; 0603; 0.01 OHM; 1%; 50PPM; 0.33W; THICK FILM	
52	R6, R24	-	2	ERJ-2RKF5102	PANASONIC	51K	RESISTOR; 0402; 51K OHM; 1%; 100PPM; 0.1W; THICK FILM	
53	R7, R25	-	2	CRCW040240K2FK	VISHAY DALE	40.2K	RESISTOR; 0402; 40.2K OHM; 1%; 100PPM; 0.063W; THICK FILM	
54	R9, R20, R26, R29, R54-R56	-	7	ERJ-2RKF1002	PANASONIC	10K	RESISTOR; 0402; 10K OHM; 1%; 100PPM; 0.10W; THICK FILM	
55	R10	-	1	ERJ-2RKF8061	PANASONIC	8.06K	RESISTOR; 0402; 8.06K OHM; 1%; 100PPM; 0.10W; THICK FILM	
56	R13, R14, R18, R19, R50	-	5	CRCW06030000Z0EAHP	VISHAY DRALORIC	0	RESISTOR; 0603; 0 OHM; 0%; JUMPER; 0.25W; THICK FILM	
57	R16	-	1	TLR2BPD3L00F75	KOA SPEER ELECTRONICS INC	0.003	RES; SMT (1206); 0.003; 1%; +/-75PPM/DEGC; 1.5W	

MAX25430A EV Kit Bill of Materials (continued)

ITEM	REF_DES	DNI/DNP	QTY	MFG PART #	MANUFACTURER	VALUE	DESCRIPTION	COMMENTS
58	R17	-	1	TLR3A10KR0025F	TE CONNECTIVITY	0.0025	RES: SMT (2512); 0.0025; 1%; +/-150PPM/DEGC; 1W	
59	R21, R27, R28, R32, R42, R46, R47	-	7	ERJ-2GE0R00	PANASONIC	0	RESISTOR; 0402; 0 OHM; 0%; JUMPER; 0.10W; THICK FILM	
60	R31, R33	-	2	CRCW04024K70FFK; MCR01MZZPF4701	VISHAY DALE; ROHM SEMICONDUCTOR	4.7K	RESISTOR; 0402; 4.7K OHM; 1%; 100PPM; 0.0625W; THICK FILM	
61	R34	-	1	CRCW06036K5FK; ERJ-3EKF6652	VISHAY DALE; PANASONIC	66.5K	RESISTOR; 0603; 66.5K OHM; 1%; 100PPM; 0.10W; THICK FILM	
62	R35	-	1	CRCW06038K87FFK	VISHAY DALE	8.87K	RESISTOR; 0603; 8.87K OHM; 1%; 100PPM; 0.10W; THICK FILM	
63	R36	-	1	AC0603FR-0715K8L; CRCW060315K8FK; ERJ-3EKF1582	YAGEO; VISHAY; PANASONIC	15.8K	RES: SMT (0603); 15.8K; 1%; +/-100PPM/DEGC; 0.1W	
64	R37	-	1	TNPW0603200KBE; RN731J1TD2003	VISHAY DALE; KOA SPEER ELECTRONICS	200K	RESISTOR; 0603; 200K OHM ; 0.1%; 100PPM; 0.1W; THICK FILM	
65	R38	-	1	TNPW060320R0BE	VISHAY DALE	20	RESISTOR; 0603; 20 OHM; 0.1%; 25PPM; 0.10W; THICK FILM	
66	R39-R41	-	3	CRG0603F10K	TE CONNECTIVITY	10K	RESISTOR; 0603; 10K OHM; 1%; 100PPM; 0.1W; THICK FILM	
67	R49	-	1	CSR0603F15L00	STACKPOLE ELECTRONICS INC	0.005	RES: SMT (0603); 0.005; 1%; +/-150PPM/DEGC; 0.25W	
68	R57	-	1	ERJ-8CWFR020	PANASONIC	0.02	RESISTOR; 1206; 0.02 OHM; 1%; 75PPM; 1W; THICK FILM	
69	SHIELD	-	1	5006	KEYSTONE	N/A	TEST POINT; PIN DIA=0.125IN; TOTAL LENGTH=0.35IN; BOARD HOLE=0.063IN; BLACK; PHOSPHOR BRONZE WIRE SILVER PLATE FINISH;	
70	SHUNT_J1, SHUNT_J6, SHUNT_J7, SHUNT_J10, SHUNT_J12, SHUNT_J14, SHUNT_J34	-	7	QPC02SXGN-RC	SULLINS ELECTRONICS CORP.	QPC02SXGN-RC	CONNECTOR; FEMALE; 0.100IN CC; OPEN TOP; JUMPER; STRAIGHT; 2PINS	
71	SW1	-	1	TDA04H0SB1	C&K COMPONENTS	TDA04H0SB1	SWITCH; SPST; 24V; 0.025A; TDA SERIES; ULTRA-MINIATURE SURFACE MOUNT HALF-PITCH DIP SWITCH; RCOIL=0.1 OHM; RINSULATION=100M OHM	
72	U1	-	1	MAX25430AATLFV+	MAXIM	MAX25430AATLFV+	EVKIT PART - IC; MAX25430AATLGV+; AUTOMOTIVE 100W USB-PD BUCK-BOOST PORT CONTROLLER AND PROTECTOR; TOFN40-EP; PACKAGE OUTLINE DRAWING: 21-0141; PACKAGE CODE: T4066-5C; LAND PATTERN NUMBER: 90-0055	
73	U2	-	1	MAX4372FEUK+	MAXIM	MAX4372FEUK+	IC; AMP; LOW-COST; MICROPOWER; HIGH-SIDE CURRENT-SENSE AMPLIFIER WITH VOLTAGE OUTPUT; SOT23-5	
74	U3	-	1	MAX4372TEUK+	MAXIM	MAX4372TEUK+	IC; AMP; LOW-COST; MICROPOWER; HIGH-SIDE CURRENT-SENSE AMPLIFIER WITH VOLTAGE OUTPUT; GAIN=20V/V; SOT23-5	
75	U4	-	1	MAX4372HEUK+	MAXIM	MAX4372HEUK+	IC; AMP; LOW-COST; MICROPOWER; HIGH-SIDE CURRENT-SENSE AMPLIFIER WITH VOLTAGE OUTPUT; SOT23-5	
76	U6, U7	-	2	MAX20075ATCA	MAXIM	MAX20075ATCA	IC; CONV; 36V 1A MINI BUCK CONVERTER WITH SUA IQ; TDFN12-EP	
77	VDD	-	1	5005	KEYSTONE	N/A	TEST POINT; PIN DIA=0.125IN; TOTAL LENGTH=0.35IN; BOARD HOLE=0.063IN; RED; PHOSPHOR BRONZE WIRE SILVER PLATE FINISH;	INSTAL KEYSTONE 5010 (LONG LOOP RED TESTPOINT)
78	PCB	-	1	MAX25430	MAXIM	PCB	PCB:MAX25430	
79	C26, C42, C46, C48	DNP	0	CC0603JRNPO9BN331	YAGEO	330PF	CAP; SMT (0603); 330PF; 5%; 50V; COG; CERAMIC CHIP	
80	C28	DNP	0	UMK107AB7105KA; CC0603KRXR98B1105	TAIYO YUDEN; YAGEO	1UF	CAPACITOR; SMT (0603); CERAMIC CHIP; 1UF; 50V; TOL=10%; TG=-55 DEGC TO +125 DEGC; TC=X7R	PACKOUT
81	C33	DNP	0	C0603C104K5RAC; C1608X7R1H104K; ECJ-1VB1H104K; GRM188R71H104KA93; CGJ3E2X7R1H104K080AA; C1608X7R1H104K080AA; CL10B104KB9NN; CL10B104KB8NFN; 06035C104KAT2A	KEMET; TDK; PANASONIC; MURATA; TDK; TDK; SAMSUNG; SAMSUNG; AVX	0.1UF	CAPACITOR; SMT (0603); CERAMIC CHIP; 0.1UF; 50V; TOL=10%; TG=-55 DEGC TO +125 DEGC; TC=X7R;	
82	CSN1, CSN2, CSP1, CSP2, DH1_GATE, DH2_GATE, DL1_GATE, DL2_GATE, DM, DP, FVBUS_I, HVDM, HVDP, LX1, LX2, OUT, VBAT_I, VCC_I	DNP	0	N/A	N/A	MICRO_TP	TEST POINT; MICRO_TP; PAD DIA: 0.8128 MM(32MILS) SOLDERMASK: 0.9144 MM(36MILS) THERMAL RELIEF/ANTIPAD: 1.574MM(62MILS); SMD	
83	J36	DNP	0	DX07P024MJ1	JAE ELECTRONIC INDUSTRY	DX07P024MJ1	CONNECTOR; FEMALE; SMT; USB 3.1; SUPERSPEED; RIGHT ANGLE; 24PINS	PACKOUT
TOTAL			177					

MAX25430A EV Kit Schematic

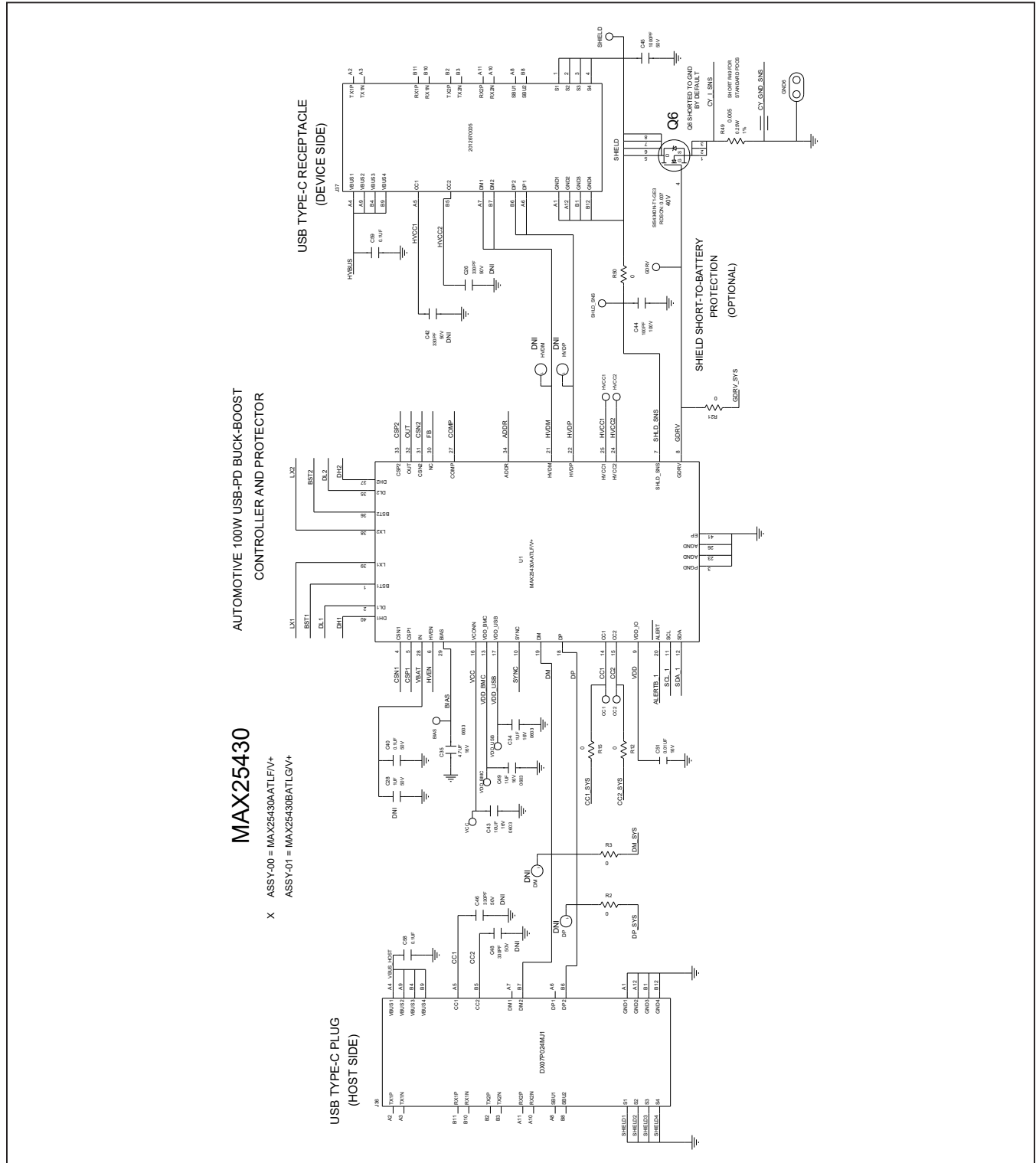

MAX25430A EV Kit Schematic (continued)

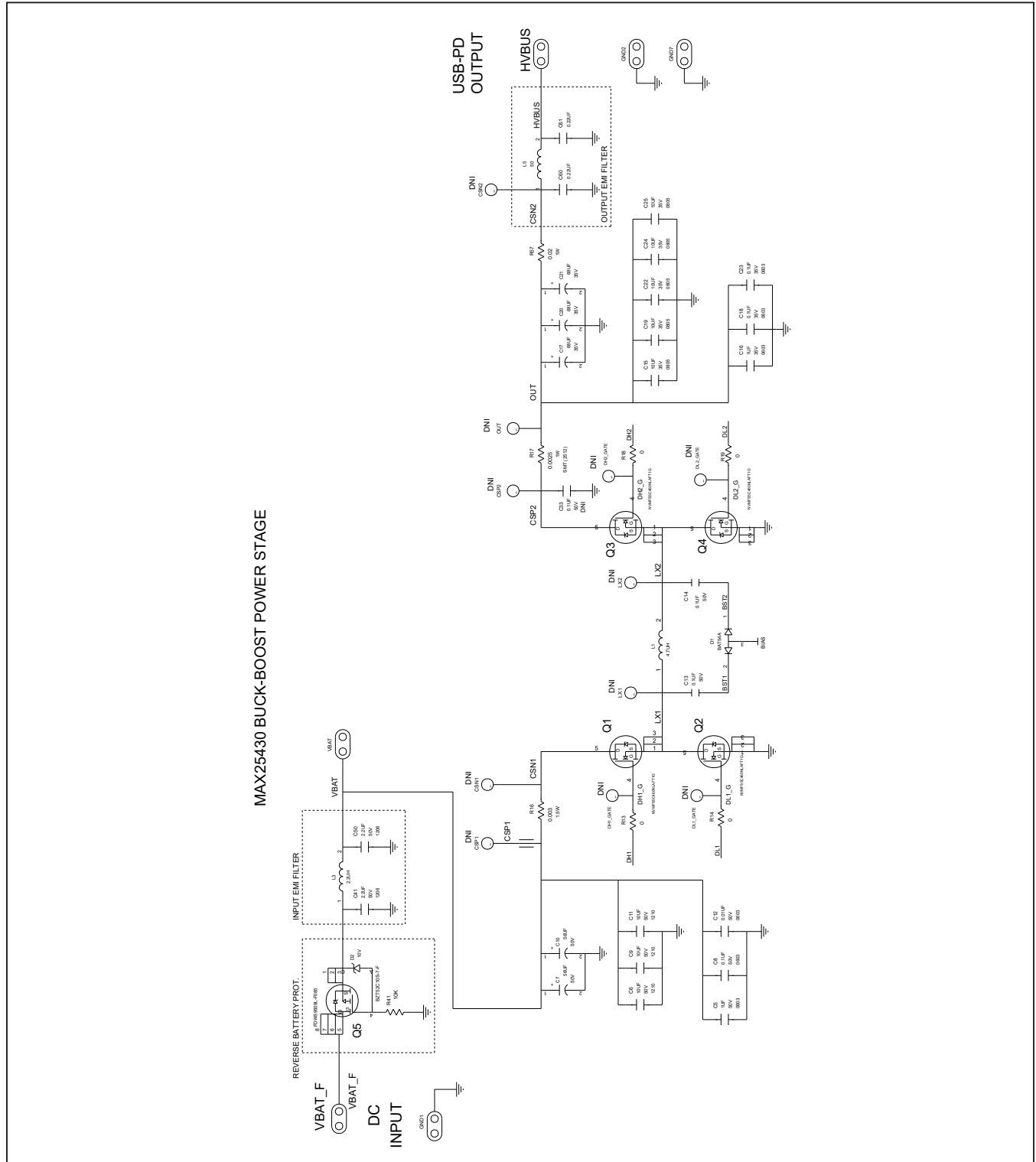

MAX25430A EV Kit Schematic (continued)

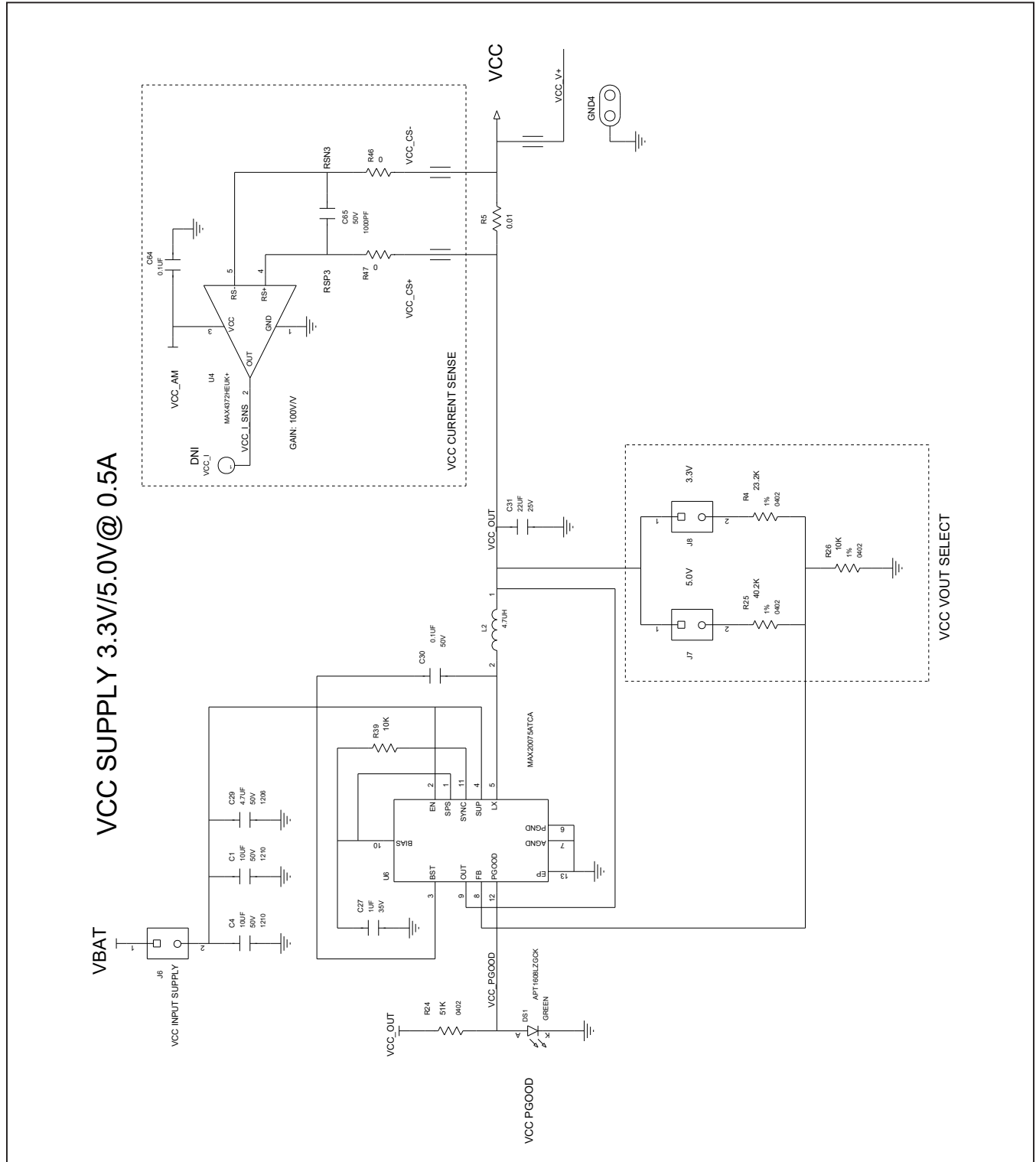

MAX25430A EV Kit Schematic (continued)

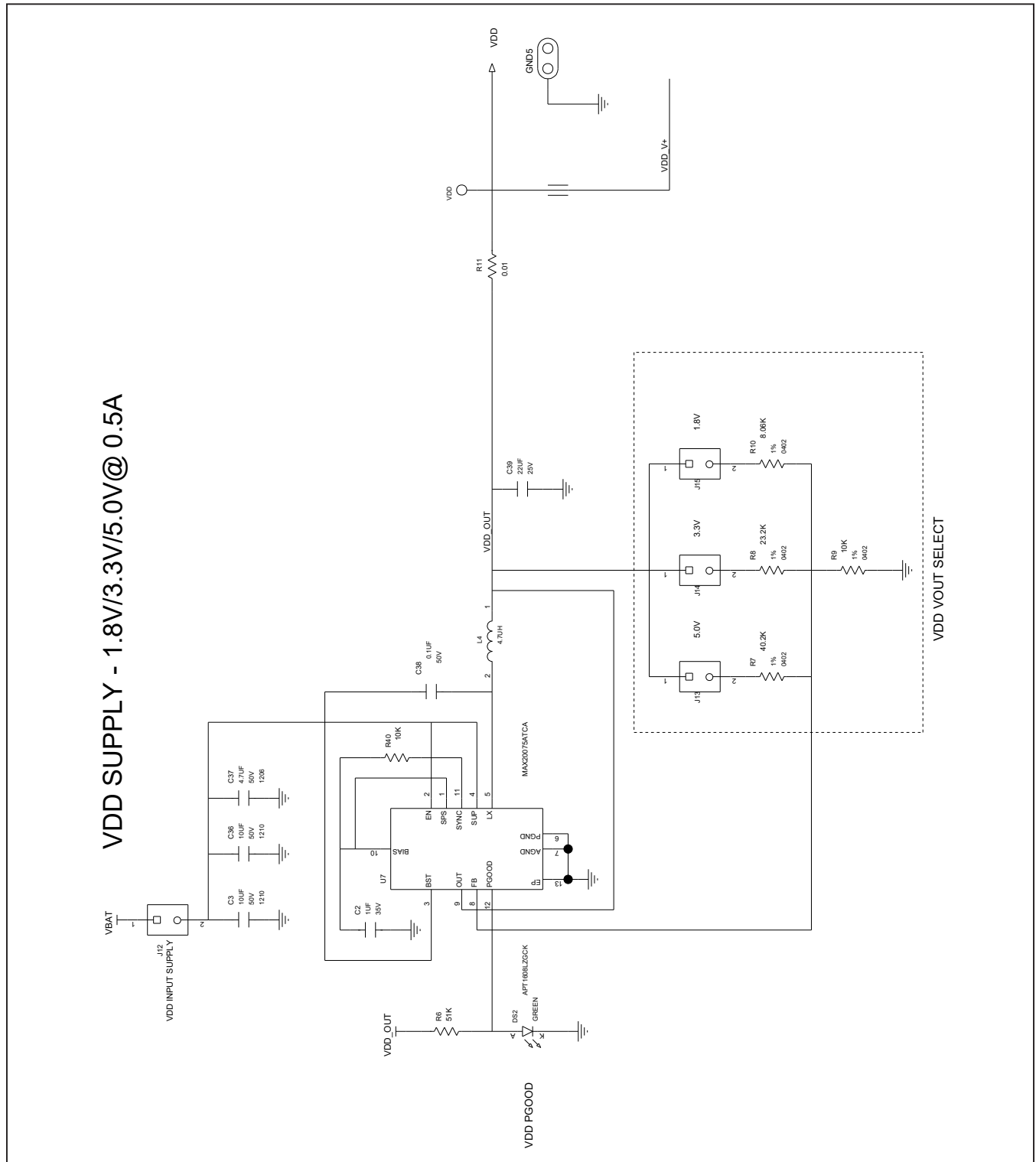

MAX25430A EV Kit Schematic (continued)

ACTIVE METERING

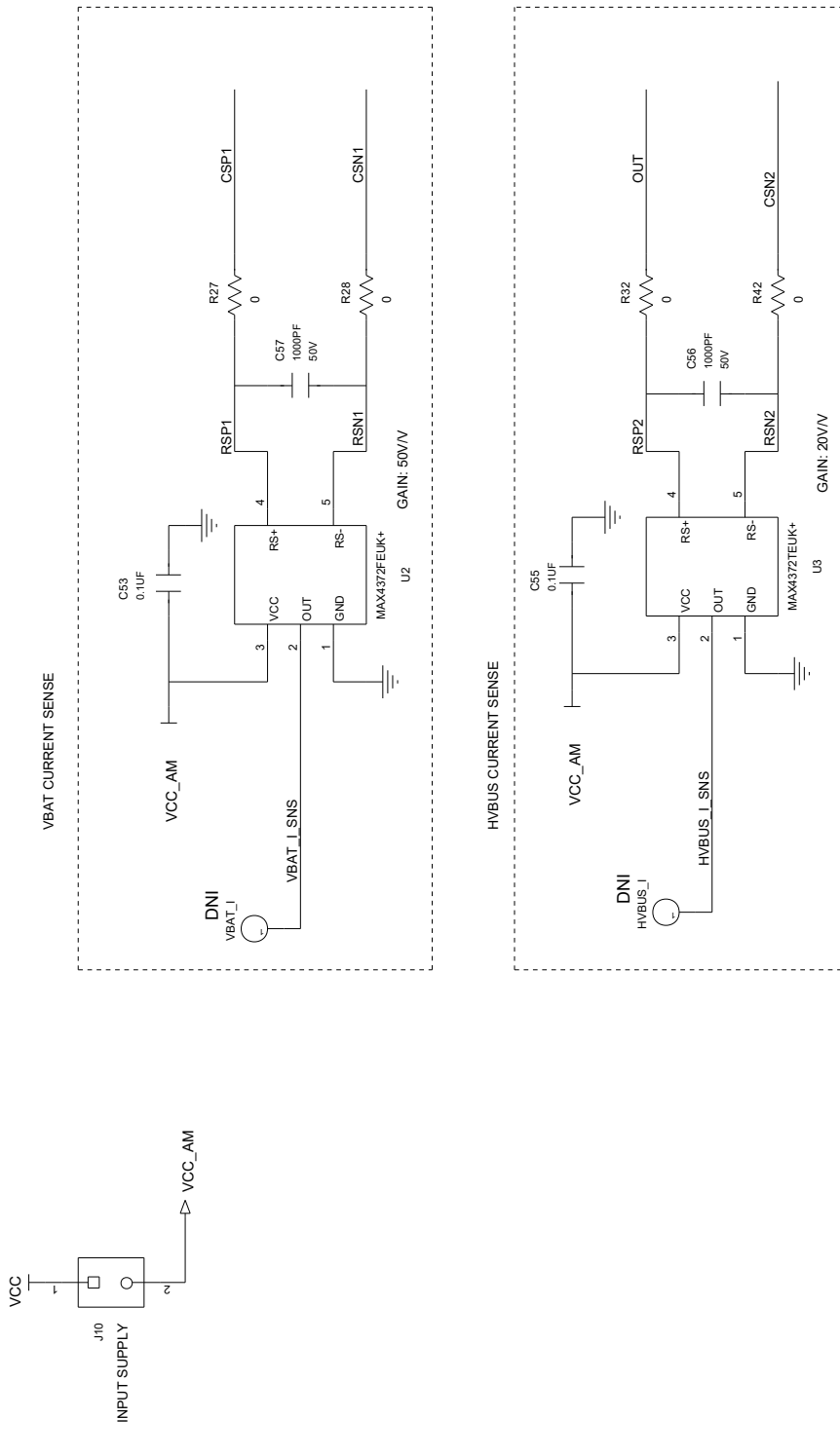

MAX25430A EV Kit Schematic (continued)

SYSTEM INTERFACE

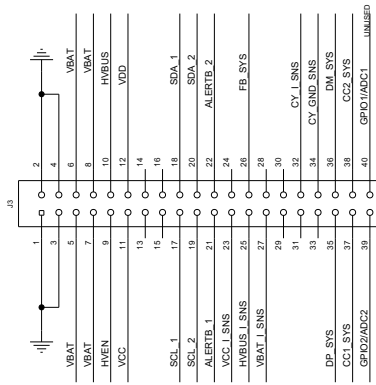

SBH11-18BIC0000A-BK

MAX25430 DIGITAL SIGNALS

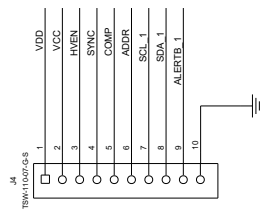

MAXPD FTHR ADAPTER INTERFACE

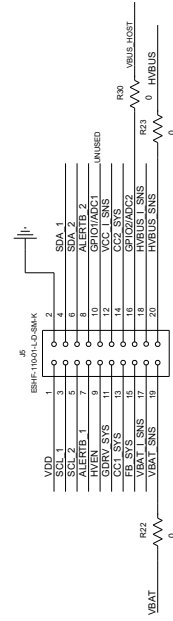

MAXPD_CY01_APPS_A Schematic (PD Controller Board) (continued)

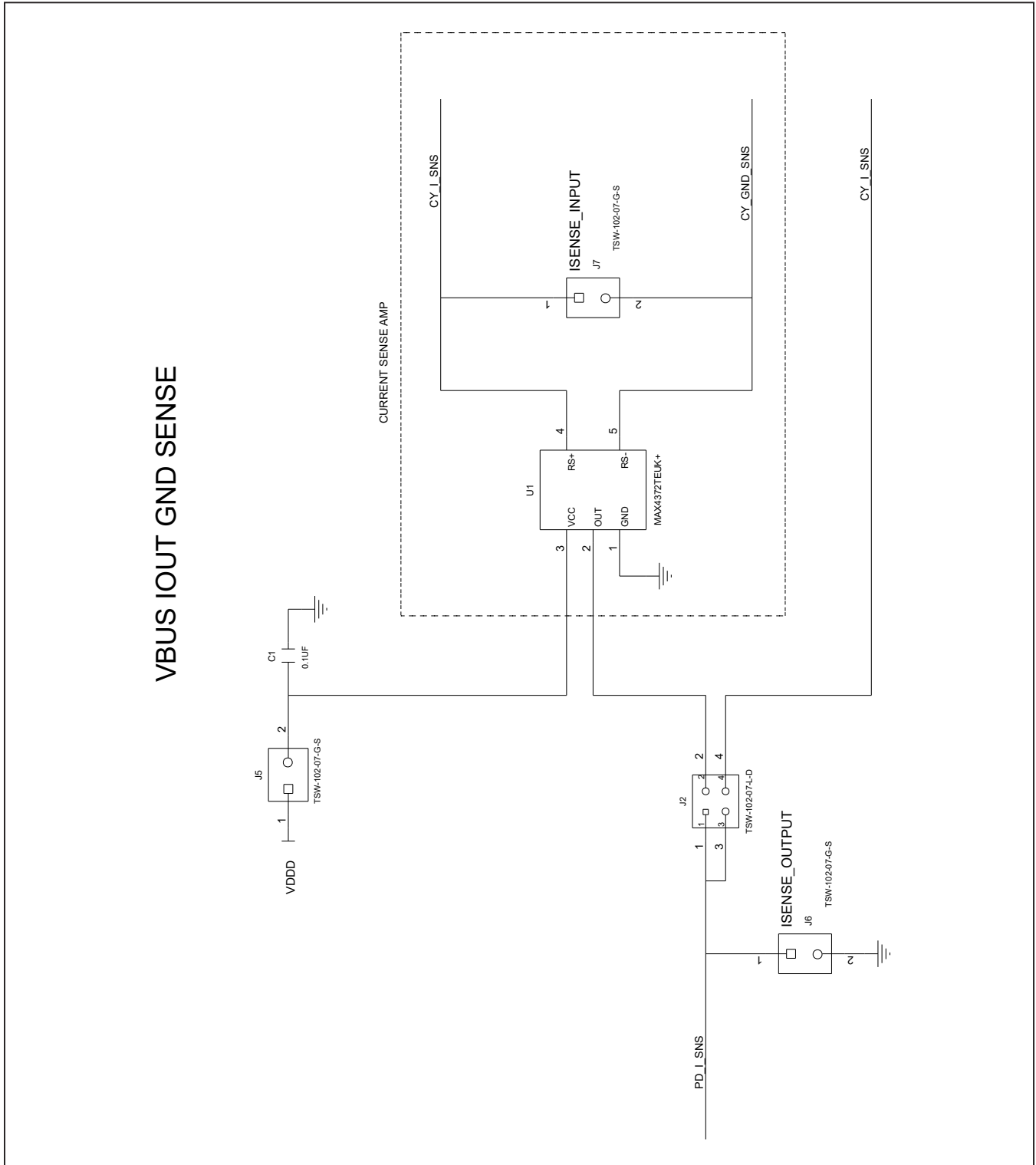

MAXPD_CY01_APPS_A Schematic (PD Controller Board) (continued)

LED INDICATORS

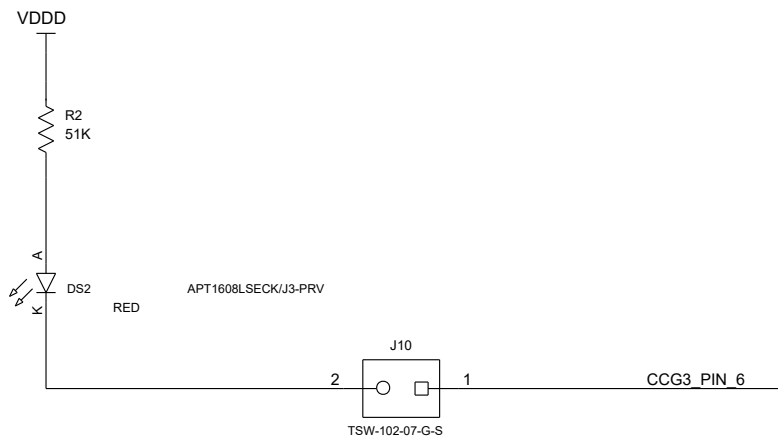
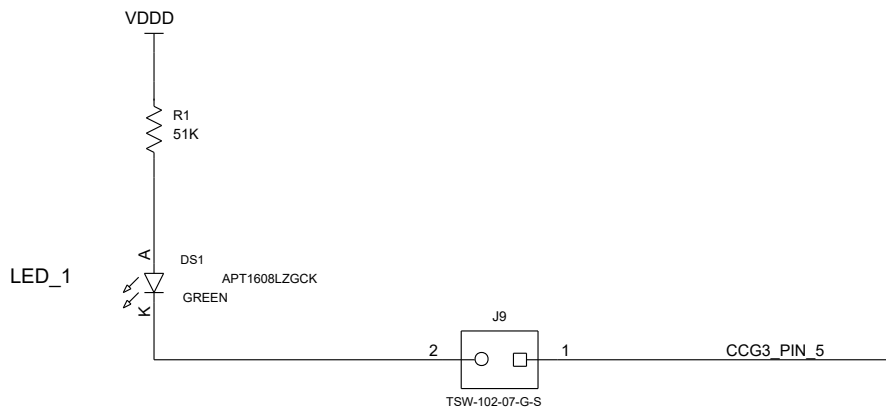

MAXPD_CY01_APPS_A Schematic (PD Controller Board) (continued)

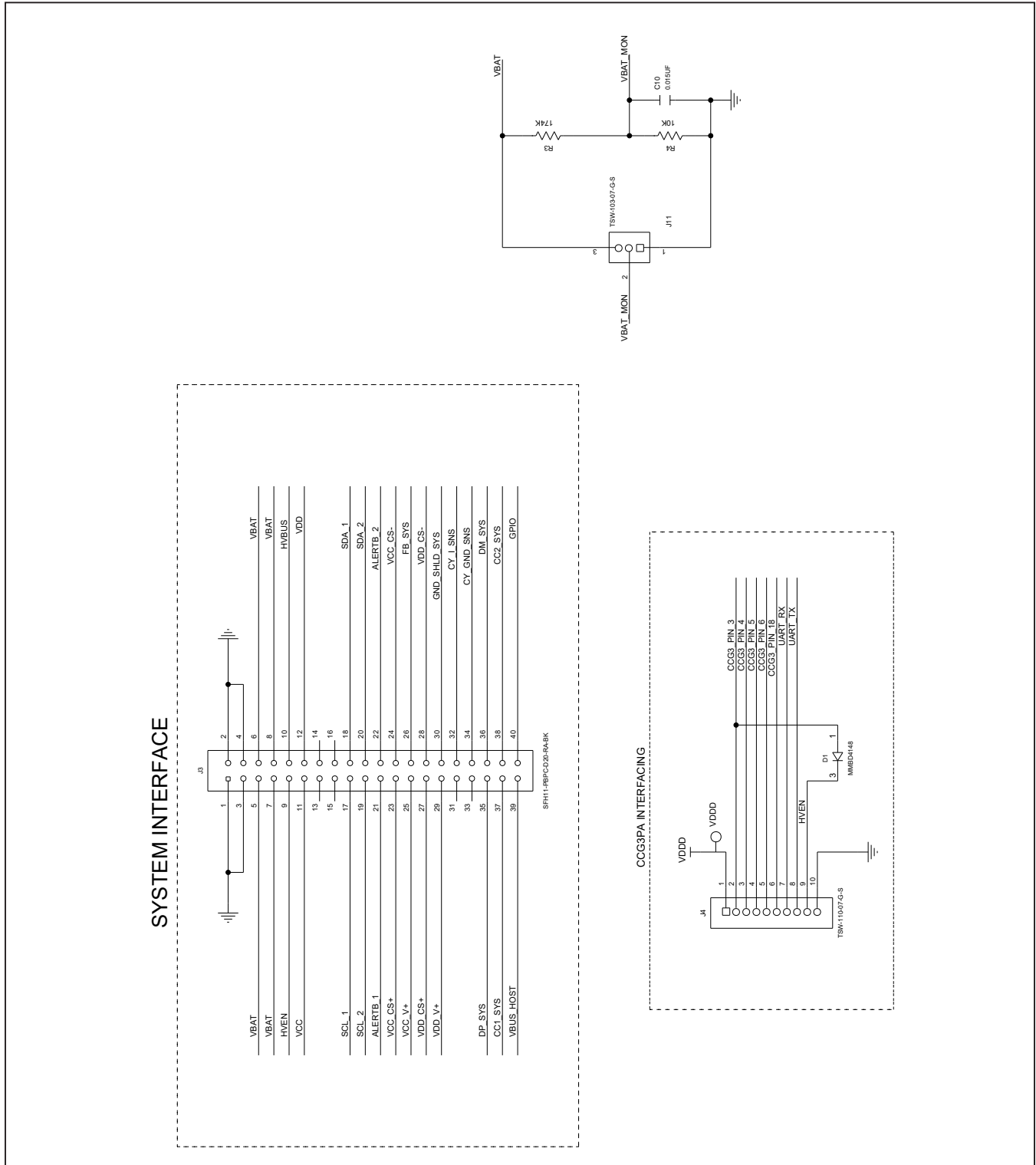

MAXPD_FTHR_APPS_B Schematic (Feather Board)

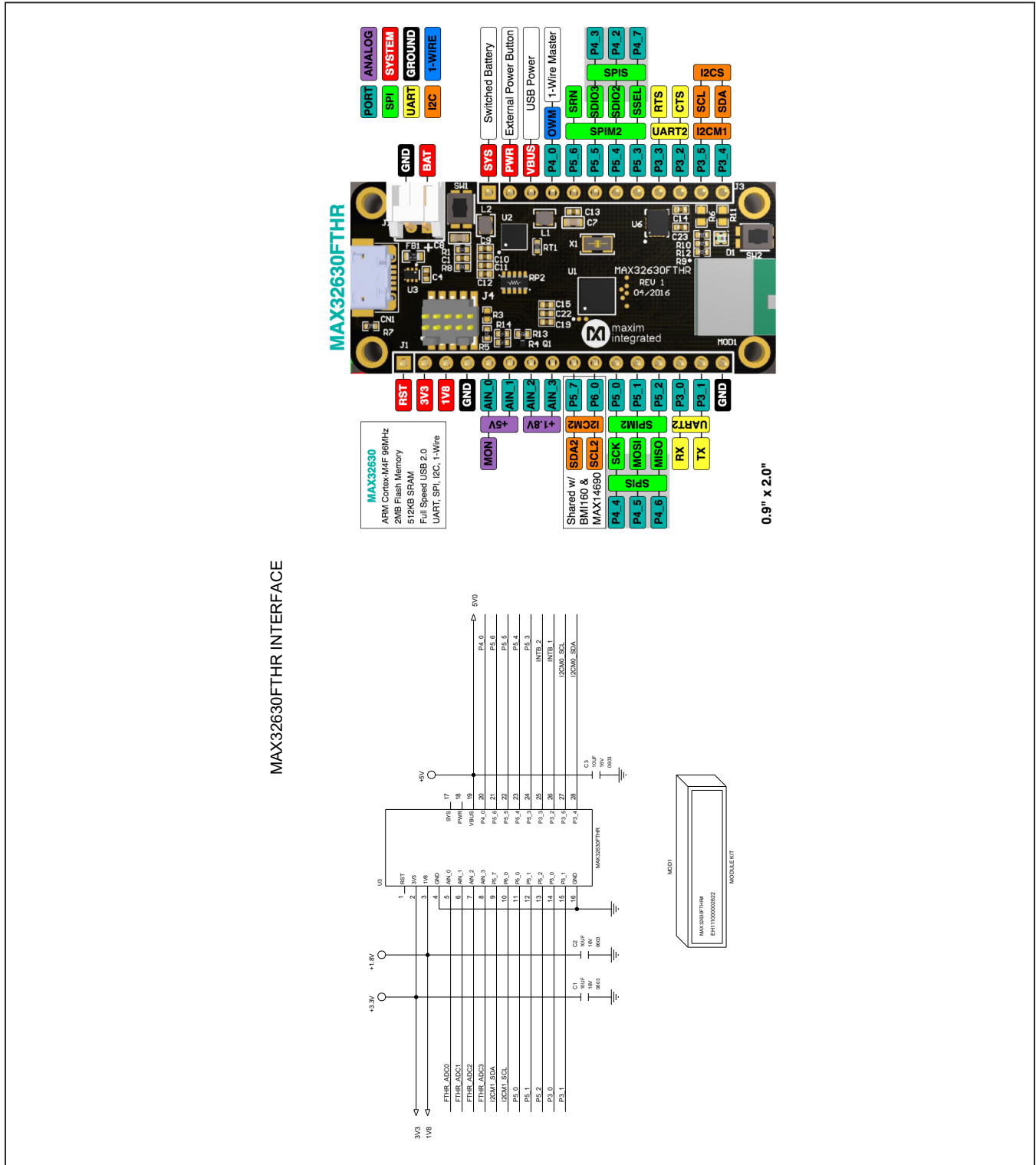

MAXPD_FTNR_APPS_B Schematic (Feather Board) (continued)

LEVEL-SHIFTERS

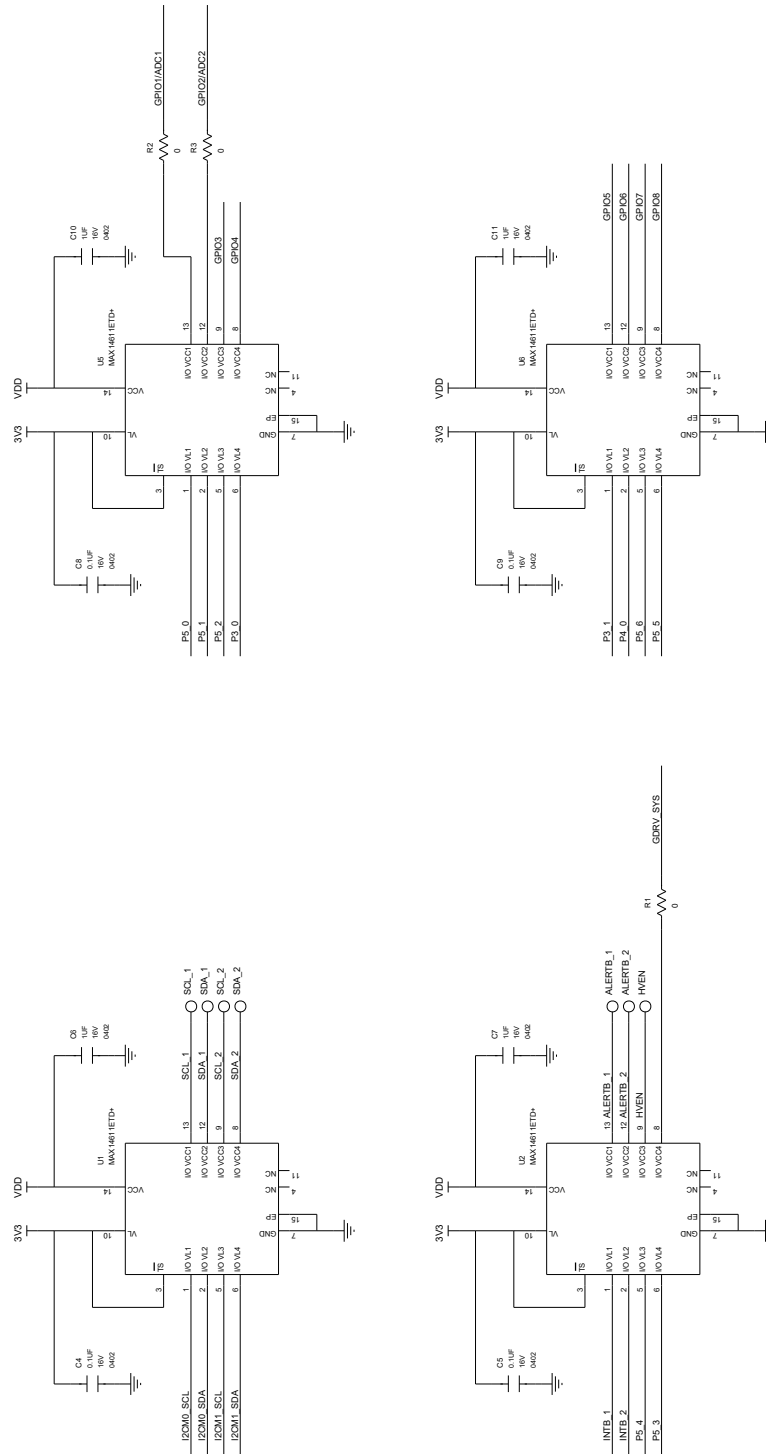

MAXPD_FTHR_APPS_B Schematic (Feather Board) (continued)

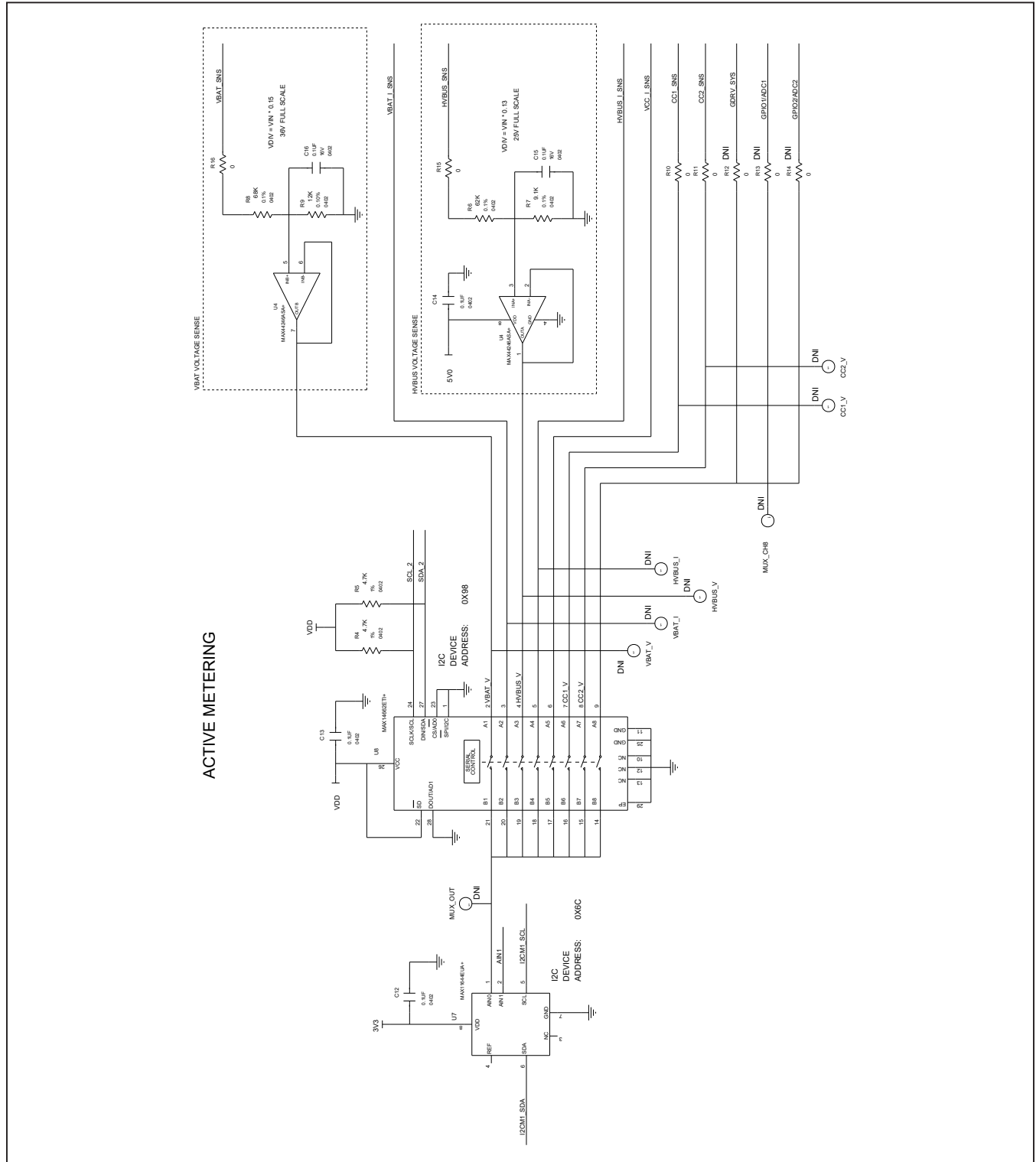

MAXPD_FTTH_APPS_B Schematic (Feather Board) (continued)

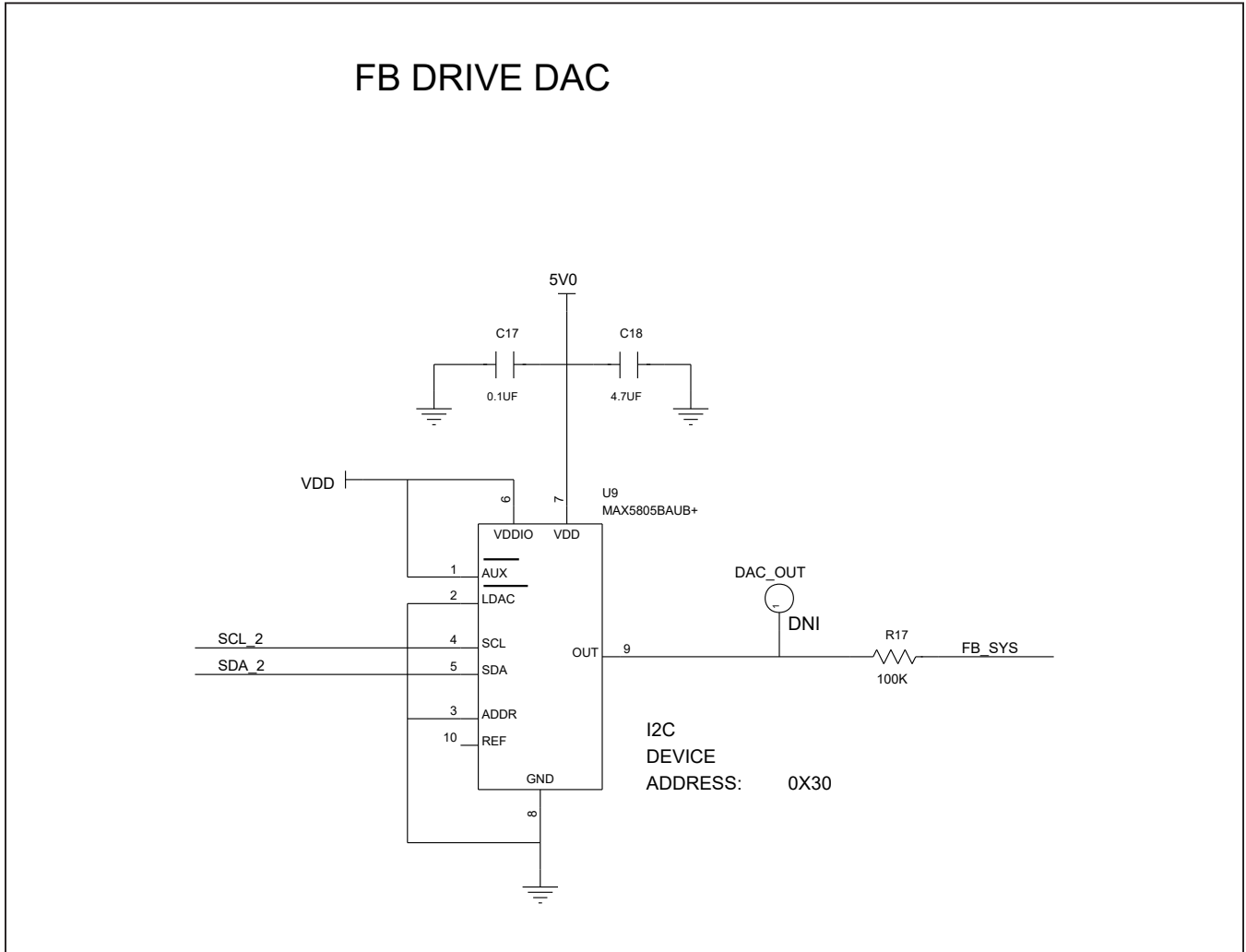

MAXPD_FTHR_APPS_B Schematic (Feather Board) (continued)

INTERFACE CONNECTORS

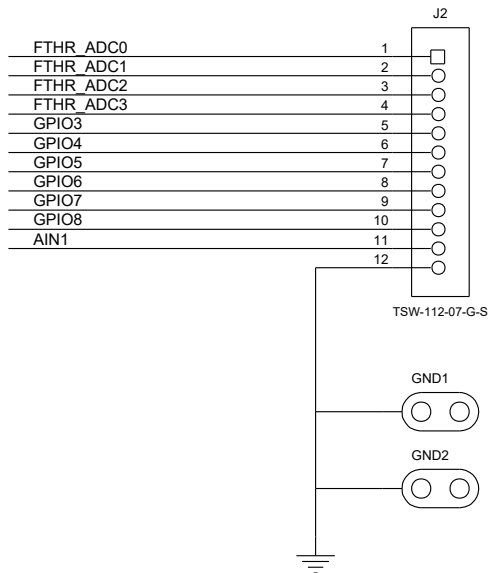
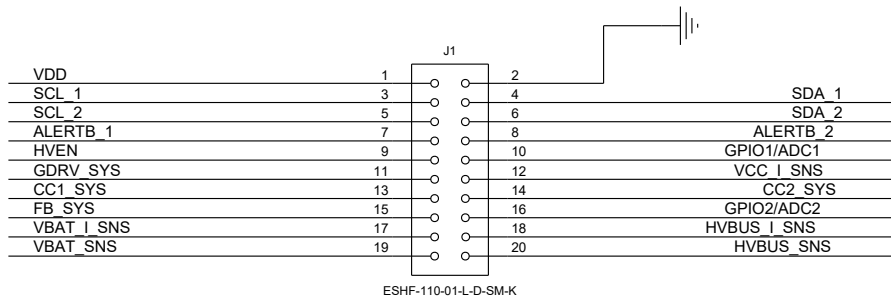

MAXPD_FTTH_APPS_B Schematic (Feather Board) (continued)

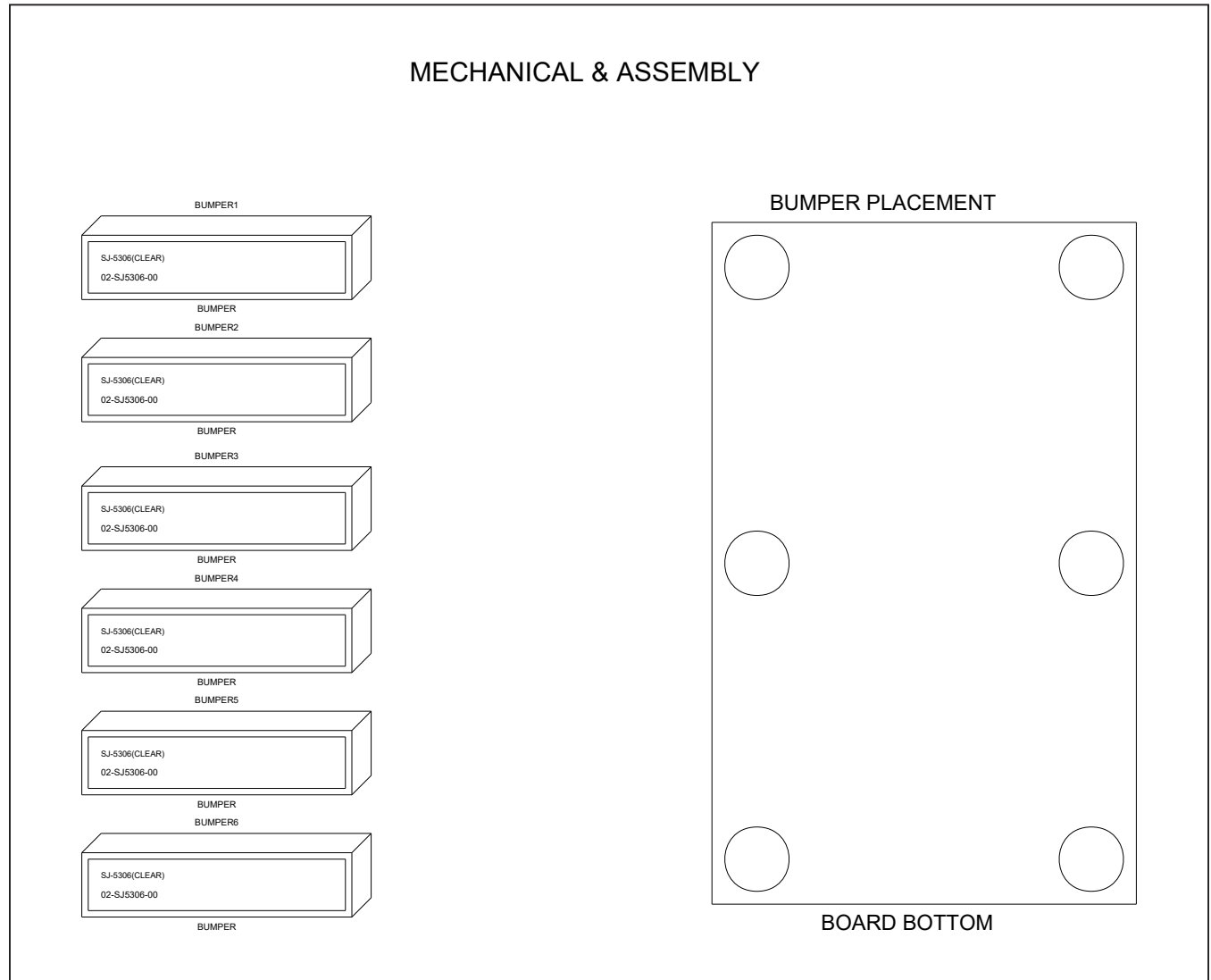

MAX25430A EV Kit Layout

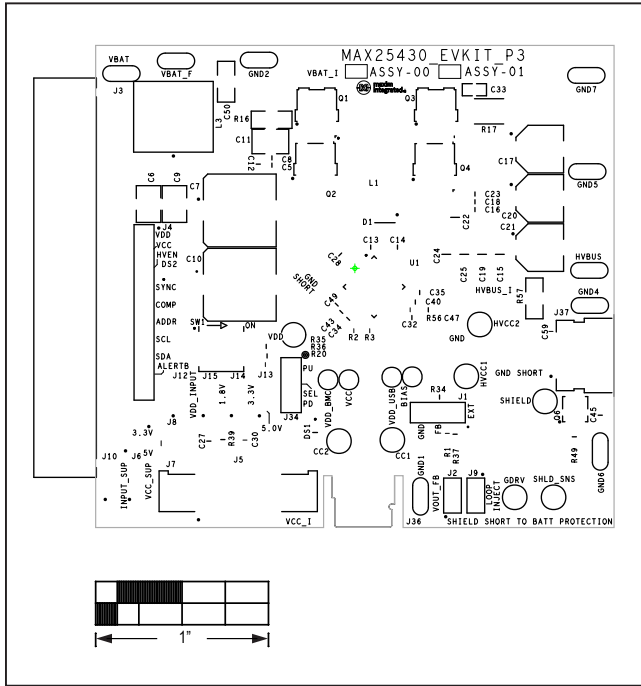

MAX25430A EV Kit PCB Layout - Top Silkscreen

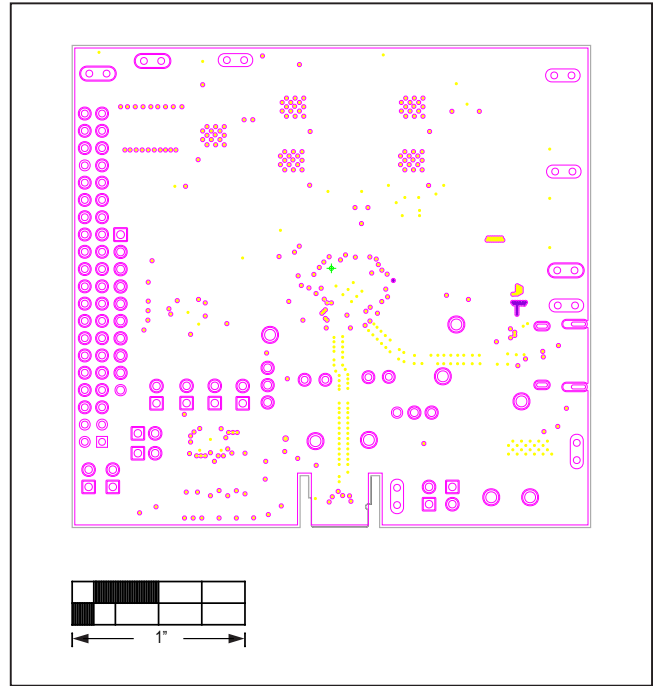

MAX25430A EV Kit PCB Layout - Layer 2

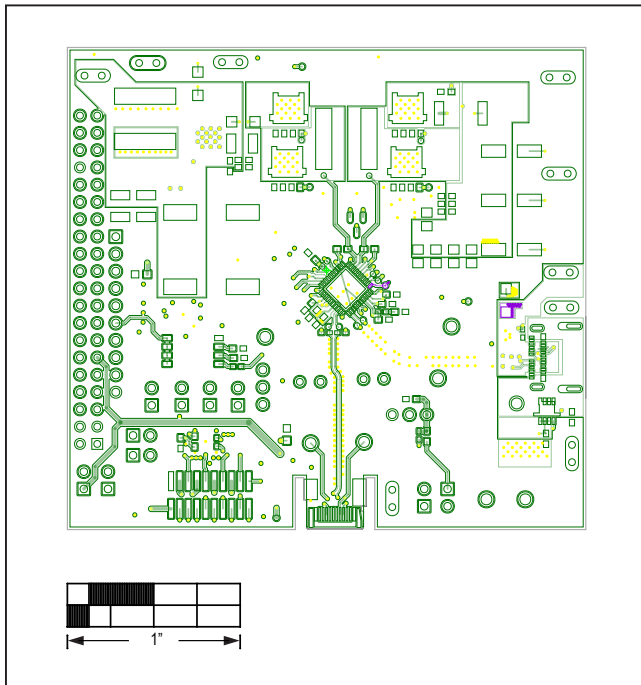

MAX25430A EV Kit PCB Layout - Top View

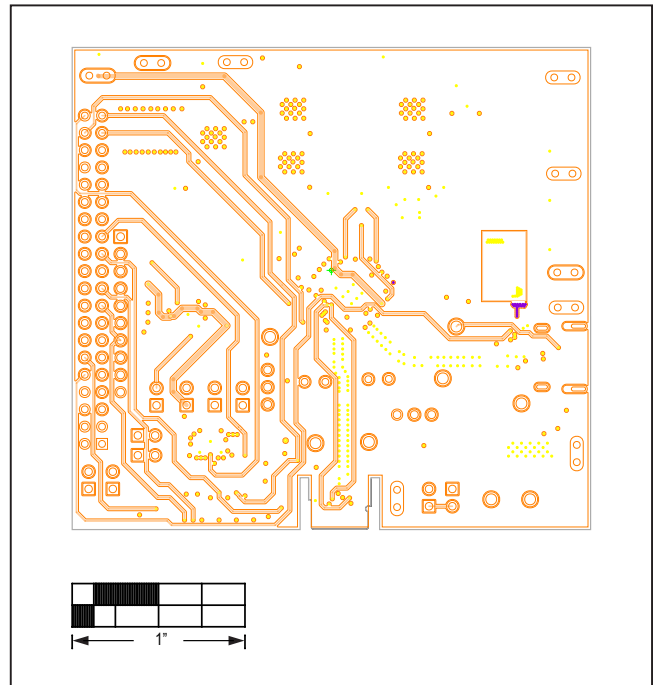

MAX25430A EV Kit PCB Layout - Layer 3

MAX25430A EV Kit Layout (continued)

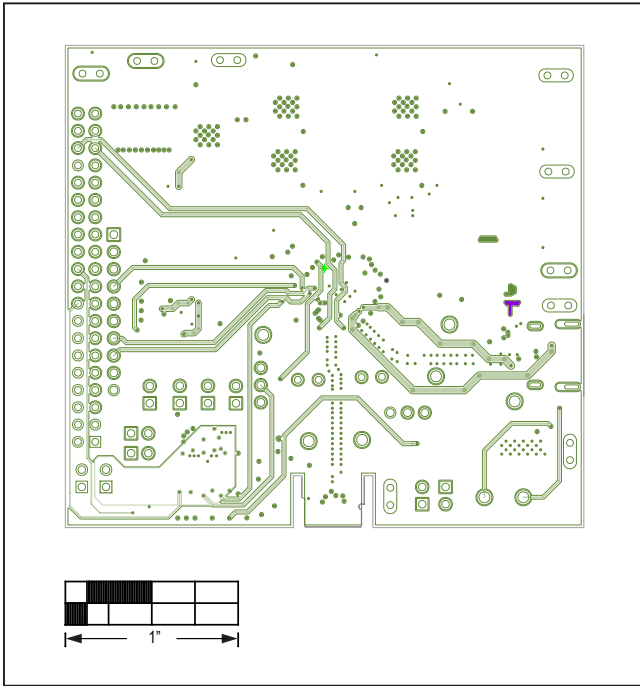

MAX25430A EV Kit PCB Layout - Layer 4

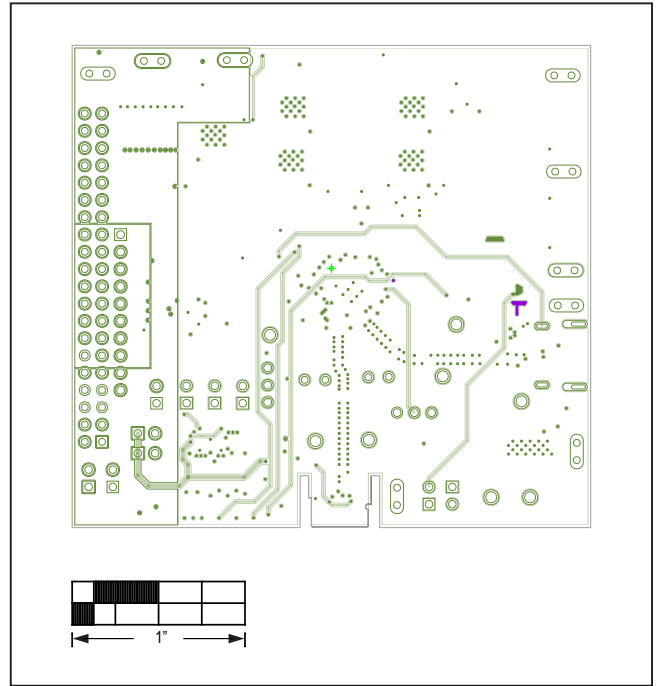

MAX25430A EV Kit PCB Layout - Layer 6

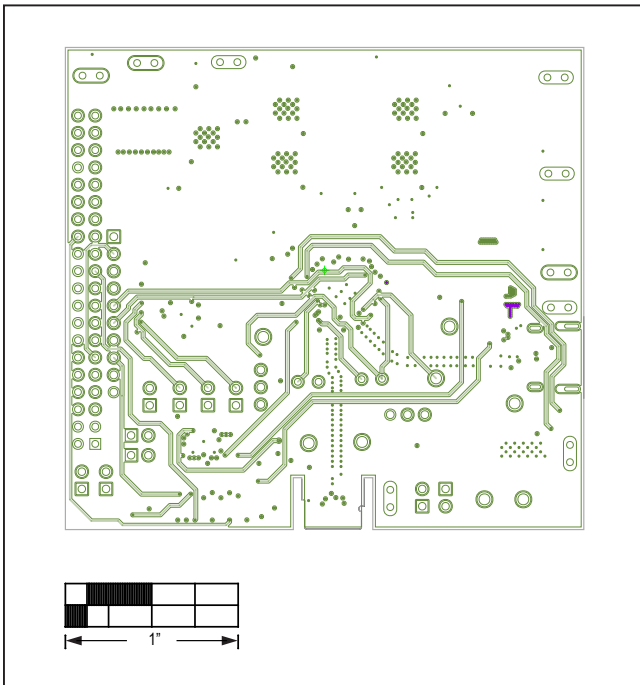

MAX25430A EV Kit PCB Layout - Layer 5

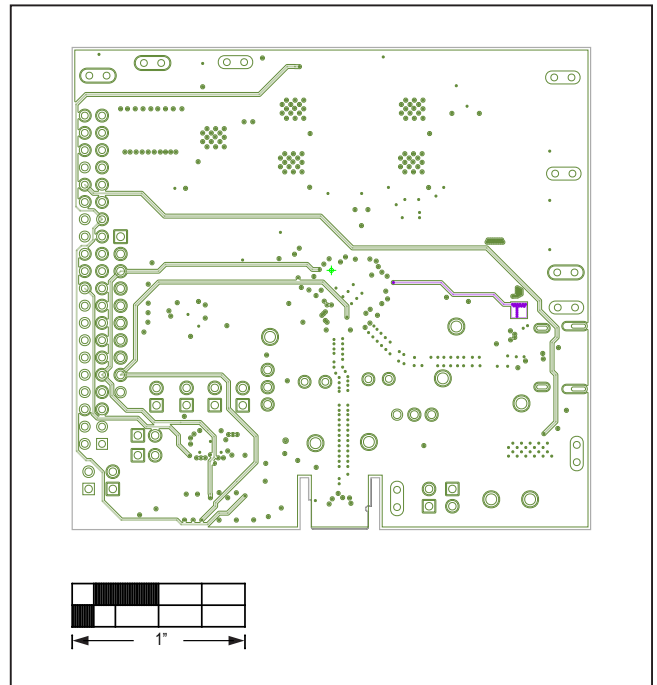

MAX25430A EV Kit PCB Layout - Layer 7

MAX25430A EV Kit Layout (continued)

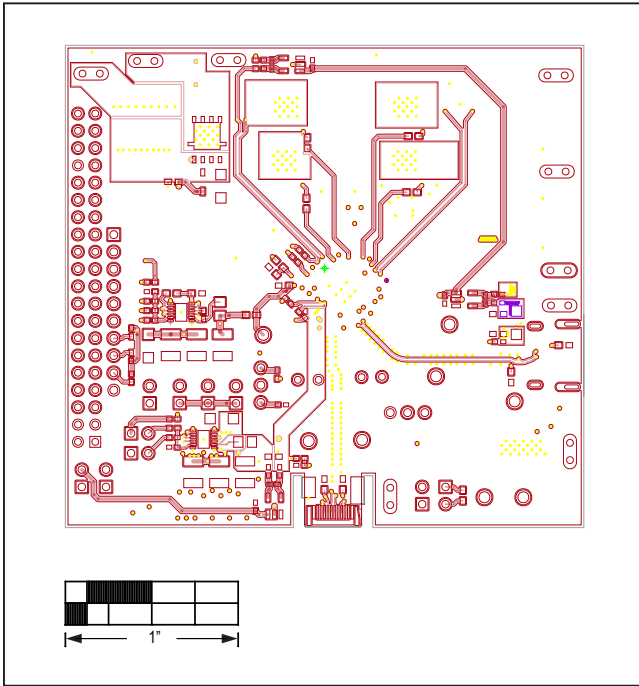

MAX25430A EV Kit PCB Layout - Bottom View

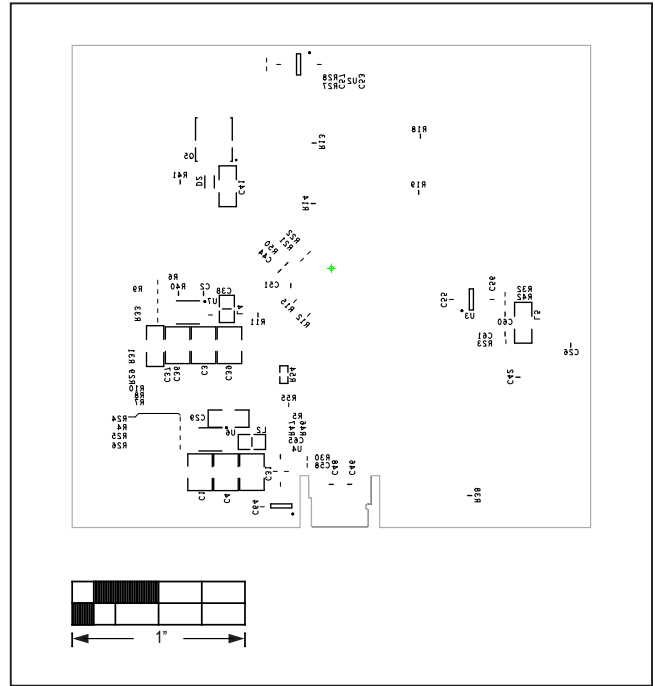

MAX25430A EV Kit PCB Layout - Bottom Silkscreen

Revision History

REVISION NUMBER	REVISION DATE	DESCRIPTION	PAGES CHANGED
0	8/20	Initial release	—
1	8/20	Changed Evaluates in header to MAX25430	1–33

For pricing, delivery, and ordering information, please visit Maxim Integrated's online storefront at <https://www.maximintegrated.com/en/storefront/storefront.html>.

Maxim Integrated cannot assume responsibility for use of any circuitry other than circuitry entirely embodied in a Maxim Integrated product. No circuit patent licenses are implied. Maxim Integrated reserves the right to change the circuitry and specifications without notice at any time.

Mouser Electronics

Authorized Distributor

Click to View Pricing, Inventory, Delivery & Lifecycle Information:

[Maxim Integrated:](#)

[MAX25430AEVKIT#](#)