

REVISIONS			
REV.	DESCRIPTION	DATE	APPROVED
A	ECO #7461	02/24/09	M.J.

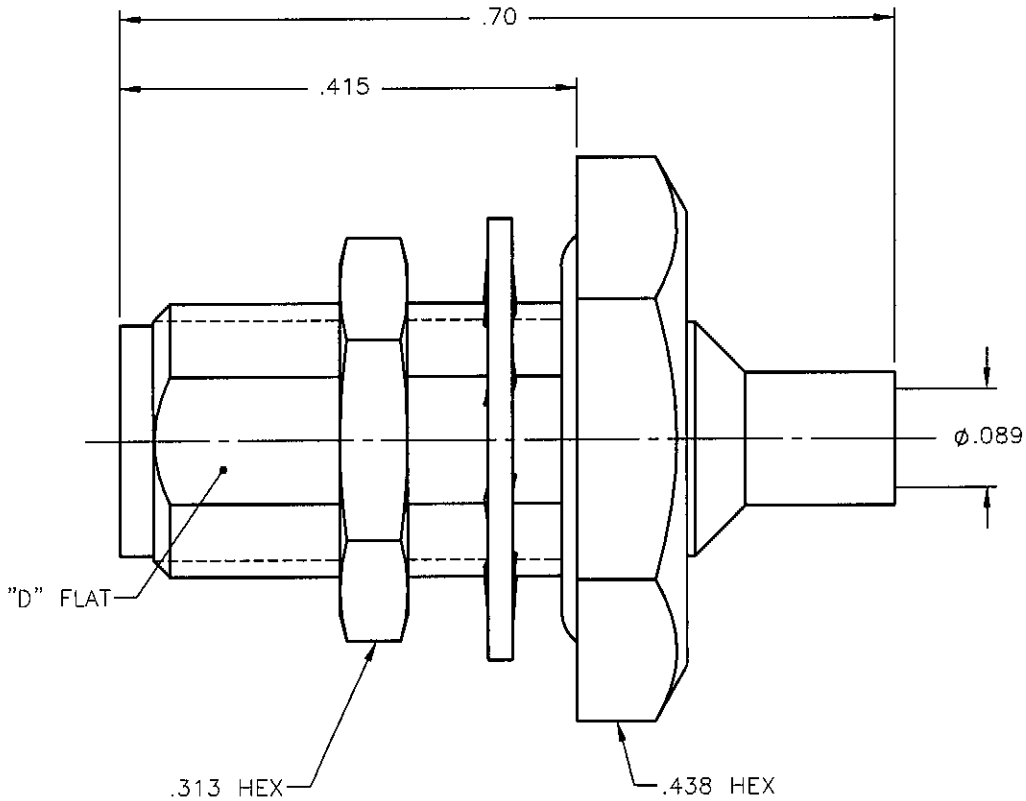

NOTES:

MATERIALS:

1. BODY & NUT = STAINLESS STEEL PER ASTM A582, ALLOY 303, CONDITION "A".
2. CONTACT = BERYLLIUM COPPER PER ASTM B196, ALLOY C17300, TEMPER TD04.
3. INSULATOR = VIRGIN WHITE TEFLON PER ASTM D1710, GRADE 1, TYPE I, CLASS "B".
4. LOCKWASHER = PHOSPHOR BRONZE PER ASTM B139, COPPER ALLOY C53400, TEMPER H04.
5. "O" RING = SILICONE RUBBER PER ZZ-R-765, CLASS 2B, GRADE 65-75.

FINISHES:

1. CONTACT = GOLD PLATE PER MIL-G-45204, TYPE II, CLASS 1, GRADE C,
OVER .00010 TO .00020 STRESS FREE SULFAMATE NICKEL PER QQ-N-290.
2. ALL OTHER METAL PARTS = GOLD PLATE PER MIL-G-45204, TYPE II, CLASS 0, GRADE C,
OVER .000050 TO .00010 STRESS FREE NICKEL PER QQ-N-290.

Property of Radiall Incorporated
This document cannot be reproduced or
communicated to a third party without prior
written permission of RADIALL Incorporated.

UNLESS OTHERWISE SPECIFIED DIMENSIONS ARE IN INCHES TOLERANCES ON	DWN: M.J.	DATE 02/24/09	APPLIED ENGINEERING PRODUCTS 104 John W. Murphy Dr. New Haven, CT 06513		
	CHKD: D.N.	DATE 02/24/09			
DECIMAL	ANGLE	APVD: J.M.	DATE 02/24/09	SMA STRAIGHT JACK BULKHEAD DIRECT SOLDER TYPE FOR .085 S/R CABLE	
REFERENCE:	MATERIALS & FINISHES: SEE NOTES	SIZE A	FSCM NO. 19505		
ORIGINATED: D.N. DATE: 06/13/83	SCALE 6:1		THIRD ANGLE PROJECTION		SHEET 1 OF 1

9453-1583-010

Mouser Electronics

Authorized Distributor

Click to View Pricing, Inventory, Delivery & Lifecycle Information:

Radial:

[9453-1583-010](#)