

LIMITATION OF LIABILITY

DANIELS MANUFACTURING CORPORATION IS NOT LIABLE FOR CONSEQUENTIAL OR SPECIAL DAMAGES OF ANY NATURE OR KIND RESULTING FROM THE USE, OR MISUSE, OF ANY OF ITS PRODUCTS. OWNERS AND USERS OF DMC PRODUCTS ASSUME FULL RESPONSIBILITY FOR INSTRUCTING THEIR EMPLOYEES IN THE PROPER AND SAFE USE OF SUCH PRODUCTS.

LIMITED WARRANTY

DMC (Daniels Manufacturing Corporation) warrants each new product sold by it to be free from defects in material and workmanship under normal use and service. DMC's obligation under this warranty is limited to the free correction or, at DMC's option, the refund of the purchase price of any such product which proves defective in normal service within ninety (90) days after delivery to the first user, provided that the product is returned to DMC with all transportation charges prepaid and which shall appear to DMC's satisfaction, after DMC's inspection, to have been defective in material or workmanship, it being understood that DMC products are not consumer products. This warranty shall not cover any damage to any product which, in the opinion of DMC, was caused by normal wear, misuse, improper operation, tampering, neglect or accident. This warranty is in lieu of all other warranties express or implied. No warranty, express or implied, is made or authorized to be made or assumed with respect to products of Daniels Manufacturing Corporation other than those herein set forth.

UH2-5 UNIVERSAL POSITIONER

DATASHEET



SEE REVERSE SIDE FOR IMPORTANT INFORMATION CONCERNING LIMITED WARRANTY, AND LIMITATION OF LIABILITY.

UH2-5 (M22520/1-05) Universal Head Assembly is used with AF8 (M22520/1-01) Crimping Tool to locate contacts horizontally and vertically between indenters.

INSTRUCTIONS

1. With Universal Positioner over crimp tool, align socket head mounting screws with tapped holes in tool. Tighten mounting screws.
2. Raise and rotate selector knob until desired wire size, indicated on selector knob, is in line with SEL. NO. index on tool body.
3. Note that selector settings shown on selector knob are based on combinations of MIL-W-16878 silver plated stranded wire and MS3190 contact wire barrels. User must establish appropriate selector settings for other contact wire combinations.
4. With lock nut in release position, turn adjustment screw IN until it stops. Insert contact through indenter opening into positioner and adjust screw OUT until indenters are centered between inspection hole and barrel end of contact. When contact contains insulation cup, center between inspection hole and bottom of insulation cup.
5. Tighten lock nut to body. Tool is now ready for crimping operation.

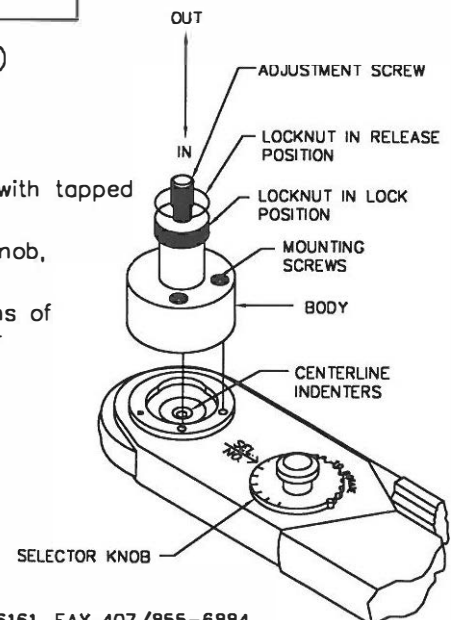

DANIELS MANUFACTURING CORP., 526 THORPE ROAD, ORLANDO, FL 32824, USA, PHONE 407/855-6161, FAX 407/855-6884
COPYRIGHT © 1996 DANIELS MANUFACTURING CORP., USA. WWW.DMCTOOLS.COM E-MAIL: OMC@DMCTOOLS.COM ALL RIGHTS RESERVED.

SEE REVERSE SIDE FOR IMPORTANT INFORMATION CONCERNING LIMITED WARRANTY, AND LIMITATION OF LIABILITY.

UH2-5 (M22520/1-05) Universal Head Assembly is used with AFB (M22520/1-01) Crimping Tool to locate contacts horizontally and vertically between indenters.

INSTRUCTIONS

1. With Universal Positioner over crimp tool, align socket head mounting screws with topped holes in tool. Tighten mounting screws.
2. Raise and rotate selector knob until desired wire size, indicated on selector knob, is in line with SEL. NO. index on tool body.
3. Note that selector settings shown on selector knob are based on combinations of MIL-W-16878 silver plated stranded wire and MS3190 contact wire barrels. User must establish appropriate selector settings for other contact wire combinations.
4. With lock nut in release position, turn adjustment screw IN until it stops. Insert contact through indenter opening into positioner and adjust screw OUT until indenters are centered between inspection hole and barrel end of contact. When contact contains insulation cup, center between inspection hole and bottom of insulation cup.
5. Tighten lock nut to body. Tool is now ready for crimping operation.

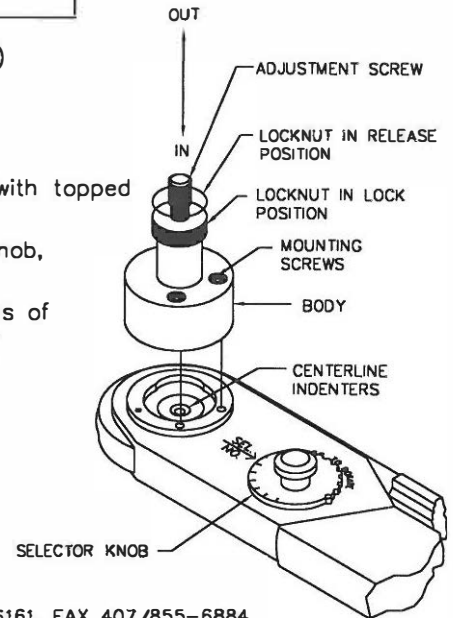

DANIELS MANUFACTURING CORP., 526 THORPE ROAD, ORLANDO, FL 32824, USA, PHONE 407/855-6161, FAX 407/855-6884
COPYRIGHT © 1996 DANIELS MANUFACTURING CORP., USA. WWW.DMCTOOLS.COM E-MAIL: DMC@DMCTOOLS.COM ALL RIGHTS RESERVED.

LIMITATION OF LIABILITY

DANIELS MANUFACTURING CORPORATION IS NOT LIABLE FOR CONSEQUENTIAL OR SPECIAL DAMAGES OF ANY NATURE OR KIND RESULTING FROM THE USE, OR MISUSE, OF ANY OF ITS PRODUCTS. OWNERS AND USERS OF DMC PRODUCTS ASSUME FULL RESPONSIBILITY FOR INSTRUCTING THEIR EMPLOYEES IN THE PROPER AND SAFE USE OF SUCH PRODUCTS.

LIMITED WARRANTY

DMC (Daniels Manufacturing Corporation) warrants each new product sold by it to be free from defects in material and workmanship under normal use and service. DMC's obligation under this warranty is limited to the free correction or, at DMC's option, the refund of the purchase price of any such product which proves defective in normal service within ninety (90) days after delivery to the first user, provided that the product is returned to DMC with all transportation charges prepaid and which shall appear to DMC's satisfaction, after DMC's inspection, to have been defective in material or workmanship, it being understood that DMC products are not consumer products. This warranty shall not cover any damage to any product which, in the opinion of DMC, was caused by normal wear, misuse, improper operation, tampering, neglect or accident. This warranty is in lieu of all other warranties express or implied. No warranty, express or implied, is made or authorized to be made or assumed with respect to products of Daniels Manufacturing Corporation other than those herein set forth.

Mouser Electronics

Authorized Distributor

Click to View Pricing, Inventory, Delivery & Lifecycle Information:

[Daniels Manufacturing:](#)

[M22520/1-05](#)