



10. Hammers and striking tools

▶ Hammers - mallets 462



- Graphite handle hammers..... 462
- Hickory handle hammers..... 464
- Club and sledge hammers and wooden mallets 467

▶ Soft-faced hammers and mallets 468



- Dead-blow hammers 468
- Interchangeable-tip mallets..... 468
- Drifts 470

▶ Soft-faced hammers and mallets 471



- 3-material drift set 471
- Sets of tips..... 472

▶ Flat chisels – cape chisels

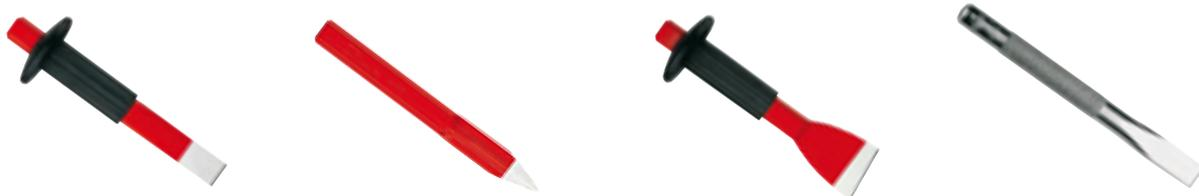

▶ Sheathed impact tools 472



▶ Impact tools 475

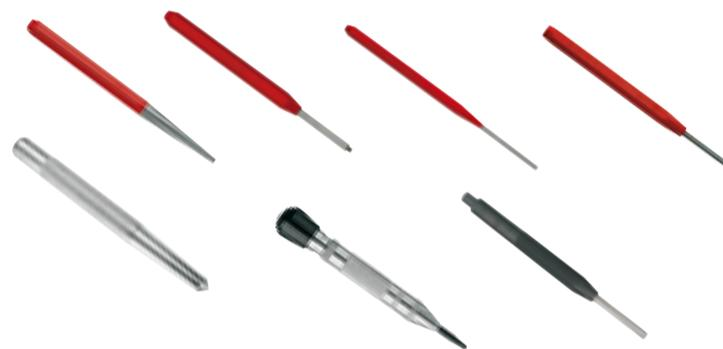

- Sheathed drift punches..... 475
- Nail sets..... 476
- Centre punches 476
- Automatic centre punches 476

▶ Impact tool sets 476



▶ Flat chisels – cape chisels 478



▶ Graphite handle hammers

New

GRAPHITE HANDLE
HAMMERS

Profiber



THE SAFE HAMMER

Maximum safety.

- Permanent epoxy resin head-to-handle connection.
- Unbreakable.

Absolute comfort

- Anti vibration : absorbent material and narrow upper handle profile to reduce vibration.

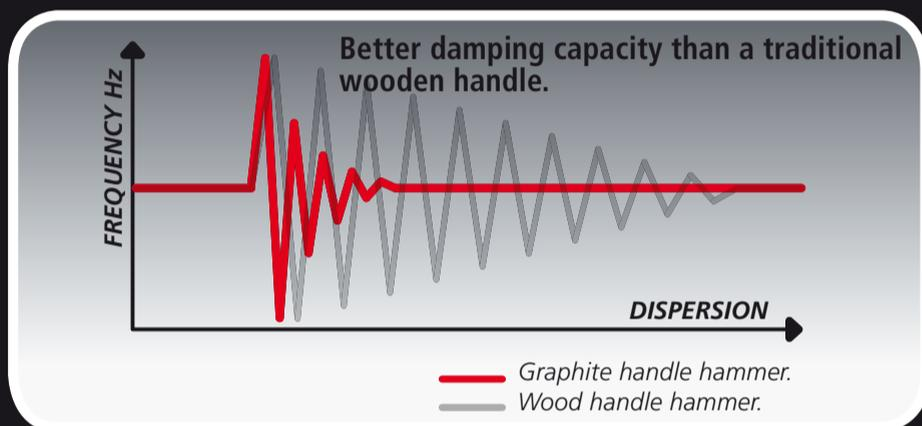
**Positive grip.**

- Soft elastomer handle for a comfortable hold.
- Wider guard to prevent loss of grip.

A combination of 3 materials for a perfect result.**1- Graphite :**

For strength. No risk of breakage.

Polypropylene :

For reduced vibration.

Elastomer :

For a perfect grip and excellent resistance to corrosive workshop liquids.

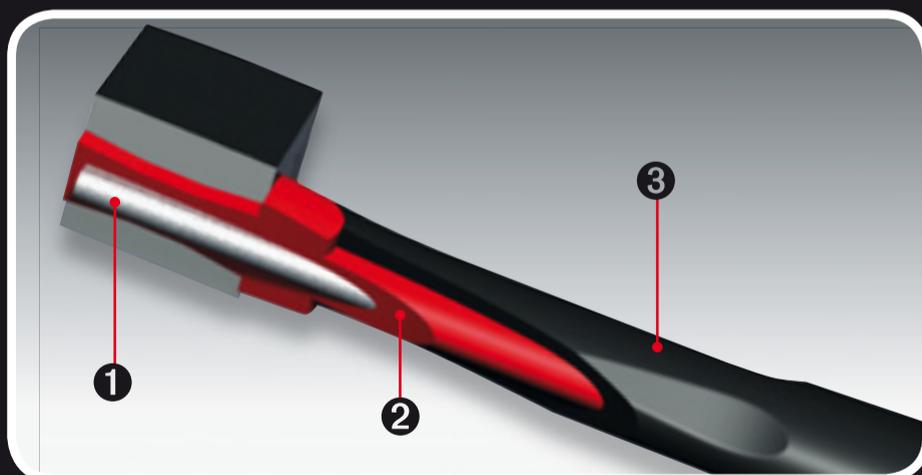

Safety first

Wear eye protection.



New

200C Graphite handle "riveting" engineers hammer

- ▷ NF E 71-014, ISO 15601.
- Graphite core safety handle.

Ref	l mm	H mm	L mm	ΔΔ kg
200C.26	80	25	245	0,345
200C.28	88	28	270	0,380
200C.30	93	30	270	0,470
200C.32	100	32	300	0,585
200C.36	106	35	300	0,725
200C.40	108	40	330	1,025
200C.42	117	42	330	1,130
200C.50	138	50	360	1,910
200C.60	151	60	380	2,800

Profiber



205C Graphite handle "DIN" engineers hammer

- ▷ ISO 15601, DIN 1041, NF ISO 15601.
- Graphite core safety handle.

Ref	l mm	H mm	L mm	ΔΔ kg
205C.20	96	19	280	0,250
205C.30	106	23	300	0,380
205C.50	122	27	320	0,580
205C.80	132	33	350	0,960
205C.100	137	36	360	1,140

Profiber



New

WOOD HANDLE HAMMERS



SAFE, ERGONOMIC AND COMFORTABLE

Head.

"High security" triple wedge handle attachment :

- 2 steel + 1 wooden wedge for a better distribution contact surfaces between the handle and the head.

Head very firmly secured on the handle

- Precise heat treatment of the head.

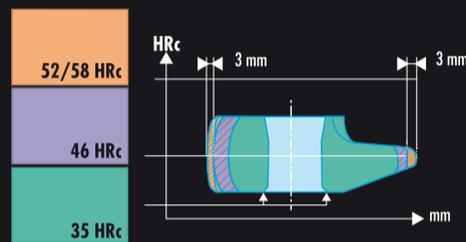

Handle.

Hickory :

- Excellent mechanical strength.
- Unaffected by climatic differences.

Octagonal handle profile :

- Exclusive to FACOM.
- Best compromise between mechanical strength and absorption of vibration.



Growth ring

Our handles are made only from blocks with a strictly defined number of growth rings as this determines the rate of growth of the tree. Fast growth, few rings, low density wood and thus low mechanical strength.

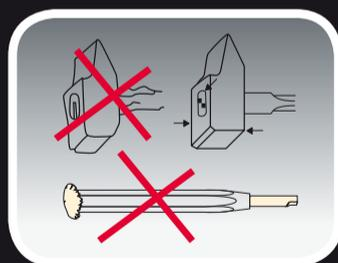

Always inspect a hammer before use. If damaged in any way, discard it. Watch out for :

- Excessively worn or mushroomed head.
- Suspect fit.
- Scored handle.

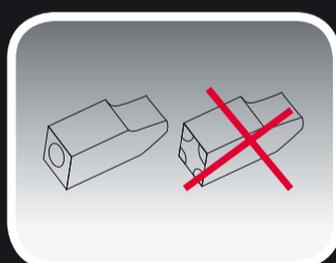

For safety, the hammer should hit dead square in the centre of the face.

Facom hammers are quality tools. Steady precise blows will prolong tool life.

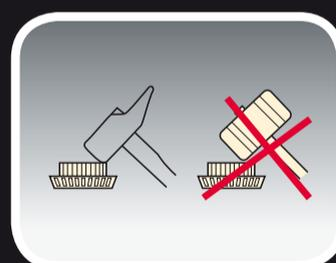

Flying chips are dangerous. never hammer materials harder than 46 HRC. Use a FACOM mallet instead.

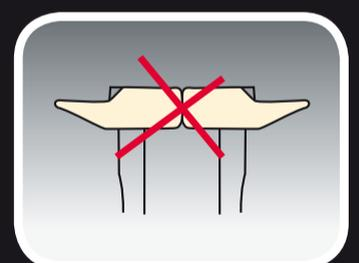

Always choose the, correct head, of appropriate weight and size :

the FACOM range includes models for all applications.



Safety first

Wear eye protection



Hammers - mallets

200H Riveting hammers

▷ NF E 71-014, ISO 15601.

- Hickory handle, "high security" triple wedge design (1 wooden and 2 metal wedges).

	l	H	L		$\Delta\Delta$
	mm	mm	mm	Hickory	kg
200H.26	80	25	245	210.MHB01	0,345
200H.28	88	28	270	210.MHB02	0,380
200H.30	93	30	270	210.MHB03	0,470
200H.32	100	32	300	210.MHB04	0,585
200H.36	106	35	300	210.MHB04	0,725
200H.40	108	40	330	210.MHB05	1,025
200H.42	117	42	330	210.MHB05	1,130
200H.50	138	50	360	210.MHB06	1,910
200H.60	151	60	380	210.MHB27	2,800

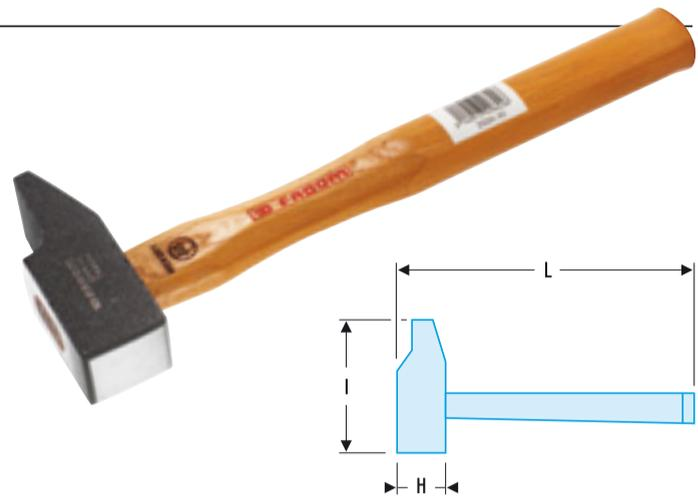

Impact tool module

MOD.MI1

200H.32 Hammer.

208A.32CB Mallet.

263.20 Chisel.

256.6 Centre punch.

248. Long drift punches 4 - 5 - 6 mm.

- Complete with tray PL.333.

$\Delta\Delta$: 1.800 kg.



205H "DIN" engineers hammers

▷ ISO 15601, DIN 1041, NF ISO 15601.

- Hickory handle, "high security" triple wedge design (1 wooden and 2 metal wedges).

	l	H	L		$\Delta\Delta$
	mm	mm	mm	Hickory	kg
205H.20	96	19	280	210.MHB12	0,250
205H.30	106	23	300	210.MHB13	0,380
205H.50	122	27	320	210.MHB14	0,580
205H.80	132	33	350	210.MHB15	0,960
205H.100	137	36	360	210.MHB16	1,140

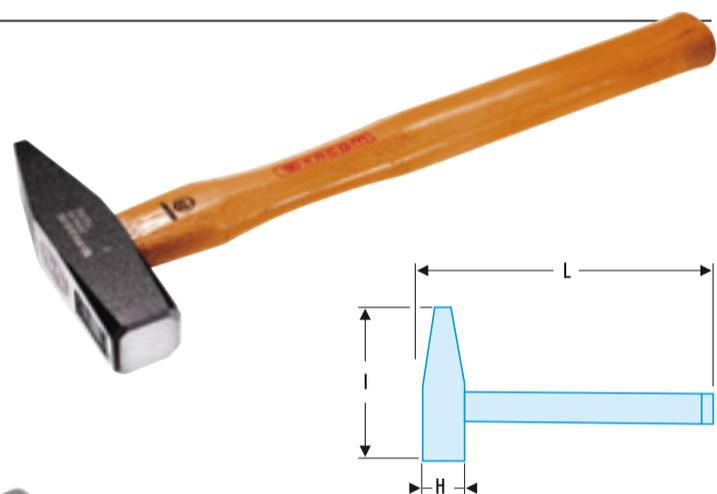

Impact tool module 205

MOD.MI3

- Comprising :

- 205H.50 Hammer.

- 208A.32CB Mallet.

- 263.18 Chisel.

- 256.6 Centre punch.

- 248. Long drift punches 4 - 5 - 6 mm.

- Tray PL.333.

$\Delta\Delta$: 1.705 kg.



202H Ball pein engineers hammers

▷ ISO 15601.

- Hickory handle, "high security" triple wedge design (1 wooden and 2 metal wedges).

	l	Ø	L		$\Delta\Delta$
	mm	mm	mm	Hickory	kg
202H.1/4	65	20	275	210.MHB07	0,140
202H.1/2	84	26	297	210.MHB08	0,280
202H.1	104	31	322	210.MHB09	0,430
202H.1'1/2	123	37	363	210.MHB10	0,840
202H.2	128	40	394	210.MHB11	1,110

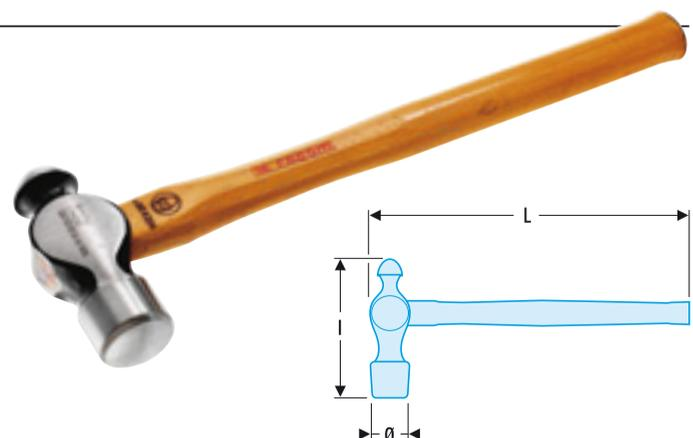

Impact tool module 202

MOD.MI4PB

202H.1/2 Hammer.

208A.32CB Mallet.

263.18 Chisel.

256.6 Centre punch.

248. Long drift punches 4 - 5 - 6 mm.

• Complete with tray PL.333.

ΔΔ : 1.45 kg.

**860H Round face dinging hammers**

▷ ISO 15601, NF ISO 15601.

• Hickory handle, "high security" triple wedge design (1 wooden and 2 metal wedges).

🔨	l mm	Ø mm	L mm	Hickory	ΔΔ kg
860H.22	104	22	280	210.MHB25	0,180
860H.26	114	26	297	210.MHB26	0,340
860H.28	118	28	297	210.MHB26	0,370
860H.30	123	30	314	210.MHB28	0,440
860H.32	134	32	339	210.MHB29	0,570
860H.36	139	36	339	210.MHB29	0,700
860H.40	149	40	377	210.MHB31	0,920

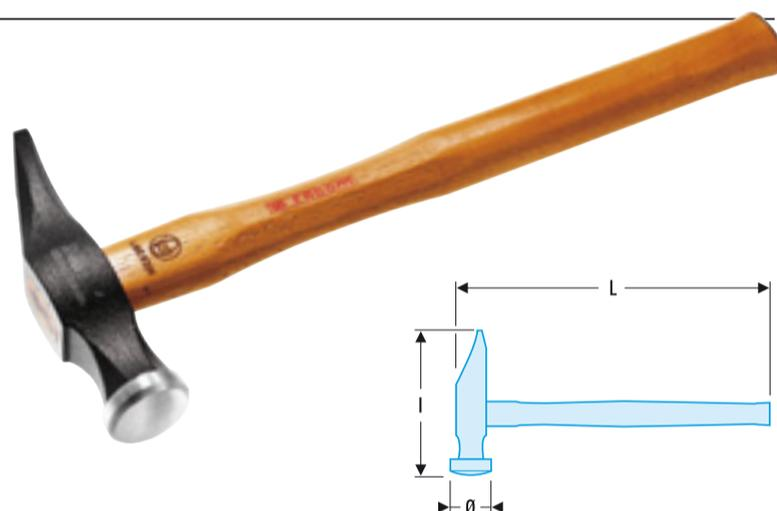
**Square face dinging hammer****859A.28**

▷ ISO 15601.

• Hickory handle, "high security" triple wedge design (1 wooden and 2 metal wedges).

ΔΔ : 560 g.

🔨	Handles	l mm	H mm	L mm	ΔΔ kg
859H.28	210.MHB34	140	28	319	0,560

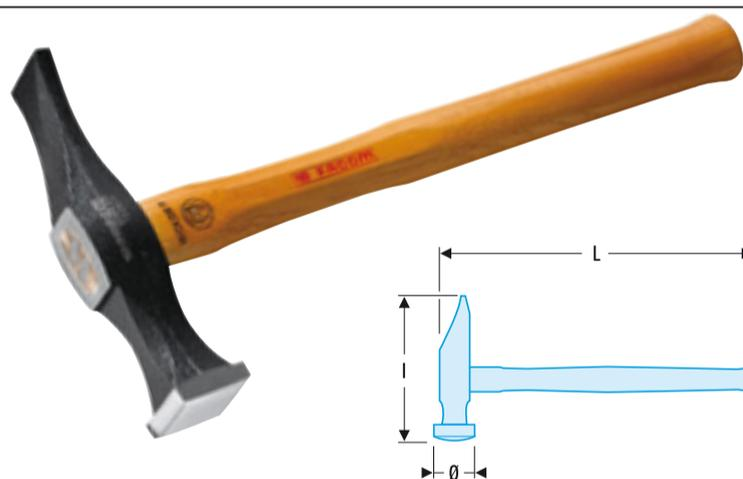
**213H Welders chipping hammers**

▷ ISO 15601, DIN 6465, NF ISO 15601.

• Hickory handle, "high security" triple wedge design (1 wooden and 2 metal wedges).

🔨	l mm	H mm	L mm	Hickory	ΔΔ kg
213H.30	170	21	270	210.MHB32	0,340
213H.40	180	21	270	210.MHB32	0,480

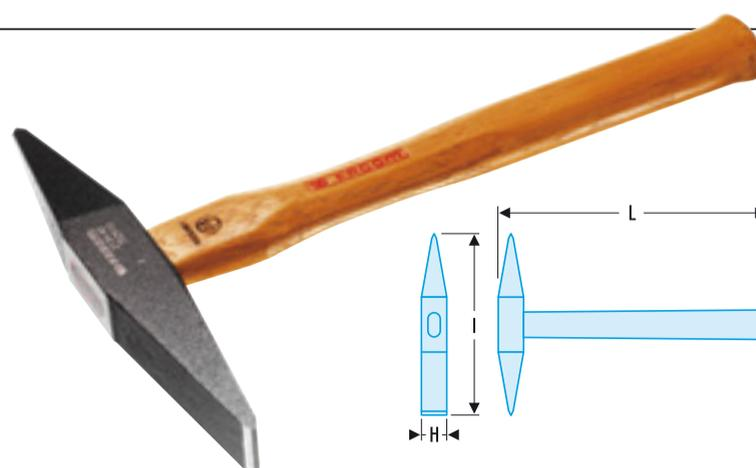

Hammers - mallets

203H Electricians hammer

▷ ISO 15601, NF E 71-011.

- Hickory handle, "high security" triple wedge design (1 wooden and 2 metal wedges).

	l	H	L		ΔΔ
	mm	mm	mm	Hickory	kg
203H.16	141	16	237	210.MHB17	0,160
203H.18	142	18	237	210.MHB18	0,200

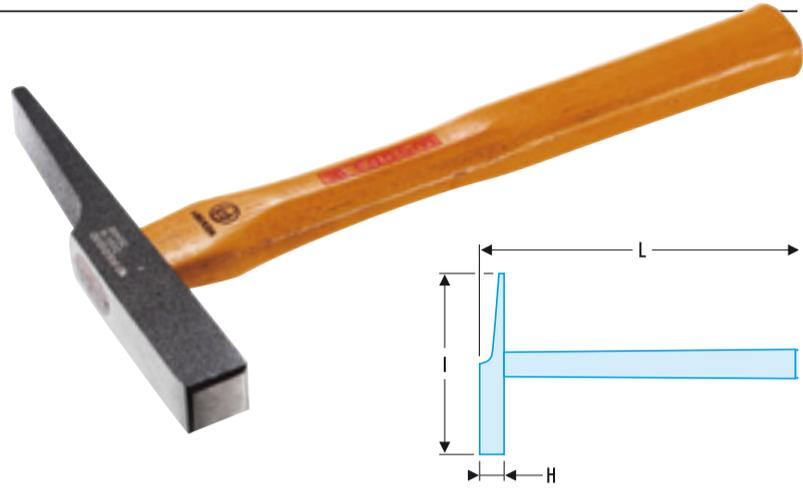

215H Joiners hammers

▷ ISO 15601, NF E 71-012.

- Hickory handle, "high security" triple wedge design (1 wooden and 2 metal wedges).

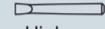
	l	H	L		ΔΔ
	mm	mm	mm	Hickory	kg
215H.20	91	20	264	210.MHB19	0,210
215H.22	99	22	283	210.MHB20	0,270
215H.26	109	26	285	210.MHB21	0,360

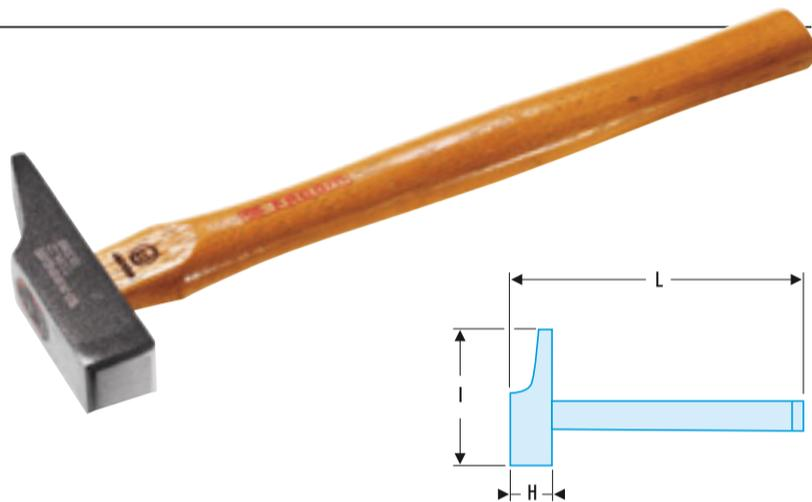

Claw hammer

204

- Permanent tubular handle, Neoprene grip.
- Balanced head with nail claw.
- Polished chrome finish.

ΔΔ : 800 g.

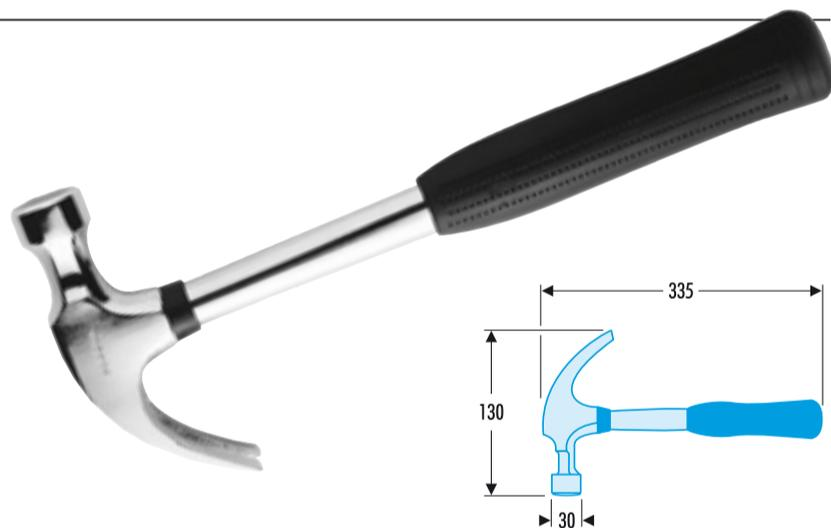

► Club and sledge hammers and wood mallets

1262H Bevelled edge club hammers

▷ ISO 15601, DIN 6475, NF ISO 15601.

- Hickory handle, "high security" triple wedge design (1 wooden and 2 metal wedges).

	l	H	L		ΔΔ
	mm	mm	mm	Hickory	kg
1262H.100	100	40	245	210.MHB22	1,000
1262H.125	105	43	248	210.MHB23	1,250
1262H.150	115	45	254	210.MHB24	1,500

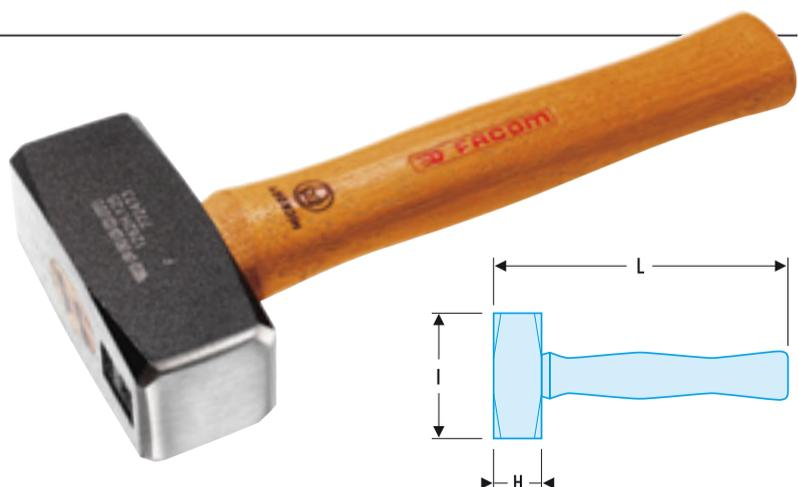

Sledge hammer

1263A.400

▷ ISO 15601, DIN 6475, NF ISO 15601.

- "High security" hickory handle.

➤	Handles	l mm	H mm	L mm	ΔΔ kg
1263H.400	210.MHB35	175	60	880	4,800
➤	Description				
210.MH45	Spare sledge hammer handle				



209 Wood mallets

▷ DIN 7462.

- Compressed laminated wood.
- Inset glass-fibre bands.
- Hornbeam handle.

➤	Ø mm	L mm	l mm	ΔΔ g
209.50	50	290	100	320
209.60	60	320	120	500
209.70	70	360	140	760

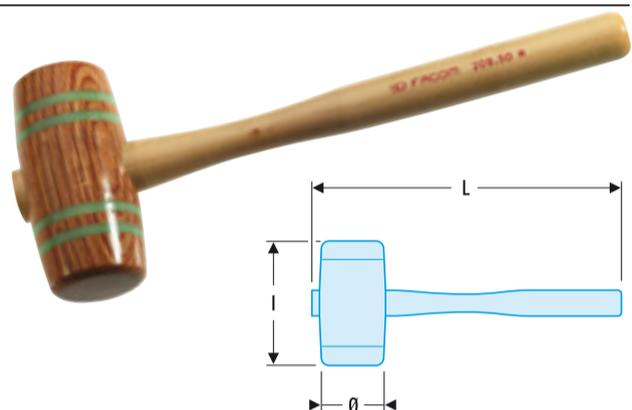

Soft face hammers

▶ Dead-blow hammers

Dead-blow hammers

SAFE, ERGONOMIC AND COMFORTABLE

Deadening the blow

- The head is half-filled with steel balls, the mass of which has sufficient inertia to counteract any tendency to bounce back. After striking, the face of the hammer remains in position, without the damaging effects of rebound when Hammering home an accurate fit. The nylon or polyurethane striking faces remove the risk of lying chips when hitting hard metal objects. Steel body and handle.

"Monobloc" polyurethane hammer

- In addition to the dead-blow feature the soft-face hammer 216 is fully moulded in a polyurethane shell.
- This monobloc design protects the head from splitting and the balls escaping in the workshop.
- The chemical-resistant polyurethane moulding gives the tips a far longer service life than conventional soft-faced hammers.

Soft face hammers

216 Dead-blow hammers, monobloc

- Steel-ball dead-blow design.
- Polyurethane encapsulated steel body and handle.
- Shore hardness D63 on striking faces.
- Ergonomic PVC grip.

➤	Ø	L	l	ΔΔ
	mm	mm	mm	kg
216.40	40	298	110	0,72
216.50	50	308	115	0,95
216.60	60	315	120	1,4

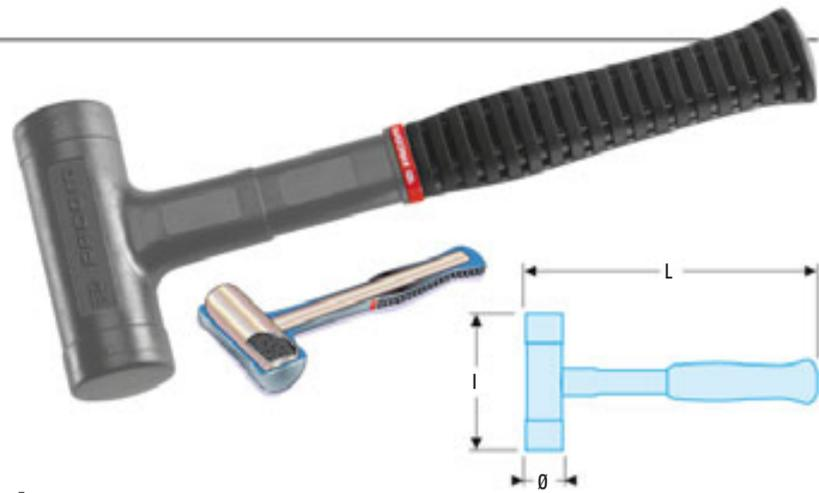

212A Dead-blow hammers, interchangeable tips

- Glass-fibre handle.
- Steel body.
- Easily replaceable, special nylon tips. Shore hardness D74.
- Ergonomic ribbed PVC grip.
- Stove-enamel hammer finish.

➤	L	l	Ø	Bits	ΔΔ
	mm	mm	mm		kg
212A.35	305	112	35	212.E35	0,69
212A.40	310	117	40	212.E40	0,76
212A.50	320	120	50	212.E50	1,07
212A.60	330	138	60	212.E60	1,68



► Interchangeable-tip mallets

207A - 208A Adaptable-tip mallets

207A : Lightweight-series, aluminium body.

208A : Heavyweight-series, brass body.

- Mallets are available with a limited number of tip combinations only, but you can customize your mallet by selecting a body and two tips of your choice.

➤	Lightweight/Heavyweight	Ø	Bits	ΔΔ
		mm		kg
207A.25CB	Lightweight-series	25	EC - EB	0,135
207A.32CB	Lightweight-series	32	EC - EB	0,205
207A.40CB	Lightweight-series	40	EC - EB	0,350
207A.50CB	Lightweight-series	50	EC - EB	0,350
207A.60CB	Lightweight-series	60	EC - EB	0,528
208A.25CB	Heavyweight-series	25	EC - EB	0,220
208A.32CB	Heavyweight-series	32	EC - EB	0,345
208A.32AB	Heavyweight-series	32	EA - EB	0,390
208A.32BB	Heavyweight-series	32	EB - EB	0,375
208A.40CB	Heavyweight-series	40	EC - EB	0,615
208A.40CC	Heavyweight-series	40	EC - EC	0,626
208A.50CB	Heavyweight-series	50	EC - EB	1,050
208A.60CB	Heavyweight-series	60	EC - EB	1,663

207A - 208A Mallet bodies

207A : Lightweight aluminium body, hickory handle.

208A : Heavyweight brass body, hickory handle.

➤	Lightweight/Heavyweight	Length	Ø	Hickory	ΔΔ
		mm	mm		kg
207A.25	Lightweight-series	280	25	210.MH12	0,135
207A.32	Lightweight-series	300	32	210.MH13	0,195
207A.40	Lightweight-series	323	40	210.MH14	0,270
207A.50	Lightweight-series	350	50	210.MH15	0,410
207A.60	Lightweight-series	363	60	210.MH16	0,610
208A.25	Heavyweight-series	280	25	210.MH12	0,235
208A.32	Heavyweight-series	300	32	210.MH13	0,340
208A.40	Heavyweight-series	323	40	210.MH14	0,525
208A.50	Heavyweight-series	350	50	210.MH15	0,830
208A.60	Heavyweight-series	363	60	210.MH16	1,260



Spare parts

■ Tips

EA : Neoprene tips. Shore hardness A75.

Replacement for rubber mallets.

EB : Cellulose tip. Shore hardness D69 ±2.

Replacement for wood and leather mallets.

EC : Polyamide tip. Shore hardness D72 ±2.

Replacement for soft-metal mallets (copper, lead, brass, aluminium).

➤	☑	Material	Ø mm
EA.25	■	Neoprene	25
EA.32	■	Neoprene	32
EA.40	■	Neoprene	40
EA.50	■	Neoprene	50
EA.60	■	Neoprene	60
EB.25	■	Cellulose	25
EB.32	■	Cellulose	32
EB.40	■	Cellulose	40
EB.50	■	Cellulose	50
EB.60	■	Cellulose	60
EC.25	□	Polyamide	25
EC.32	□	Polyamide	32
EC.40	□	Polyamide	40
EC.50	□	Polyamide	50
EC.60	□	Polyamide	60



► Drifts

214 Standard drifts

- Steel body.
- Interchangeable nylon tips.
- For use with a hammer or by hand for fitting or removing small components and bearings.
- Replacements for bronze and brass drifts.

➤	Ø mm	L mm	Bits	ΔΔ g
214.10	10	168	212.E10	100
214.12	12	170	212.E12	130
214.15	15	175	212.E15	200



214.R Dead-blow drifts

- Steel body filled with steel balls preventing rebound after striking.
- Interchangeable nylon tips.
- Large-diameter drifts which can be used on their own for fitting components gently.

➤	Ø mm	L mm	Bits	ΔΔ g
214.R20	20	150	212.E20	220
214.R25	25	150	212.E25	330
214.R30	30	155	212.E30	460
214.R35	35	155	212.E35	650



► Multi-impact tool sets



Multi-impact system

DRIFTS AND PUNCHES

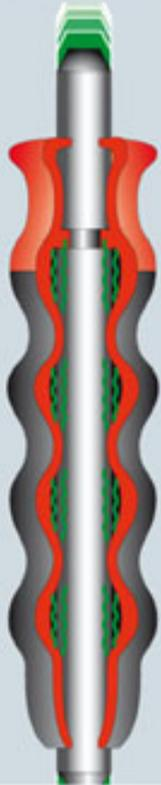

Parts protection

- Interchangeable tips of differing hardness for parts that must not be marked.
- High quality, precision tools.

Multi-solution

- Tips of 3 different materials : brass, aluminium and polyamide
- Extensive range of sizes.

Comfort and safety

- Exclusive sheathed, shock-absorbing handle.
- Slide-action for an increased shock-absorbency.
- Positive grip.



Brass/Polyamide/Aluminium drift punch set

217.GJ1

- Capacity Ø 10 to 20 mm.
- 19-piece set comprising :
 - 1 sheathed anti-vibration handle 217.G16.
 - 5 steel tips Ø 10, 12, 14, 16 and 18 mm.
Effective length 60 mm.
 - 3 brass tips Ø 12, 16, 20 mm.
Effective length 40 mm.
 - 3 polyamide tips Ø 12, 16, 20 mm.
Effective length 40 mm.
 - 1 extension 217.R12, effective length 100 mm.
 - 3 brass tips for extension Ø 12, 16, 18 mm.
Effective length 20 mm.
 - 3 polyamide tips for extension Ø 12, 16, 18 mm.
Effective length 20 mm.
- Complete with plastic case 265 x 230 x 50.
- $\Delta\Delta$: 1.35 kg.



Sheathed handle

217.G16

- Shock-absorbing handle.
- M10 x 150 threaded bit holder.
- Dimensions : 170 x 36 x 36 mm.



	Ø	L	$\Delta\Delta$
	mm	mm	g
217.G16	16	170	292



Set of tips for 217.GJ1

⇒	Set contents	Ø mm	Handle	ΔΔ g
217E.A10J3	3 aluminium tips	10	217.G16	59
217E.ALP12	1 aluminium, 1 brass and 1 polyamide tip	12	217.G16	80
217E.A14J3	3 aluminium tips	14	217.G16	88
217E.ALP16	1 aluminium, 1 brass and 1 polyamide tip	16	217.G16	117
217E.A18J3	3 aluminium tips	18	217.G16	135
217E.LP20J4	2 brass and 2 polyamide tips	20	217.G16	252
217E.LPJ6	3 brass and 3 polyamide tips	12/16/18	217.R12	122



Extension

217.R12

- M8 x 125 threaded bit holder extension.
- Dimensions : 120 x 16 x 16 mm.

⇒	Ø	L mm	ΔΔ g
217.R12	12	105	100



Sheathed series



Sheathed series - A step forward



NEW ULTRA-COMFORTABLE ANTI-ROLL SHEATH

Ergonomic

- Shock-absorbing.
- Elastic sheath.
- Partly free-sliding sheath.
- More stable, more positive grip.
- Protects the hand.

Safe

- Choice of best steels.
- Very precise heat treatment with different harnesses.
- DIN 7255.
- FACOM specifications.
- Better shock absorbance and elasticity to avoid the risk of breakage.

Precise and Powerful

- Comfortable grip ensures an accurately aimed blow.
- Stability of tool ensures a more powerful blow.

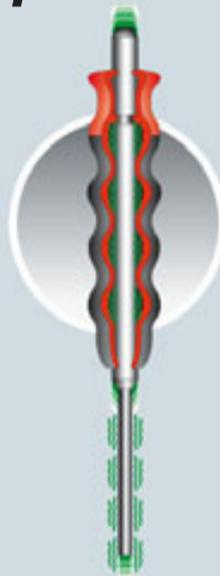
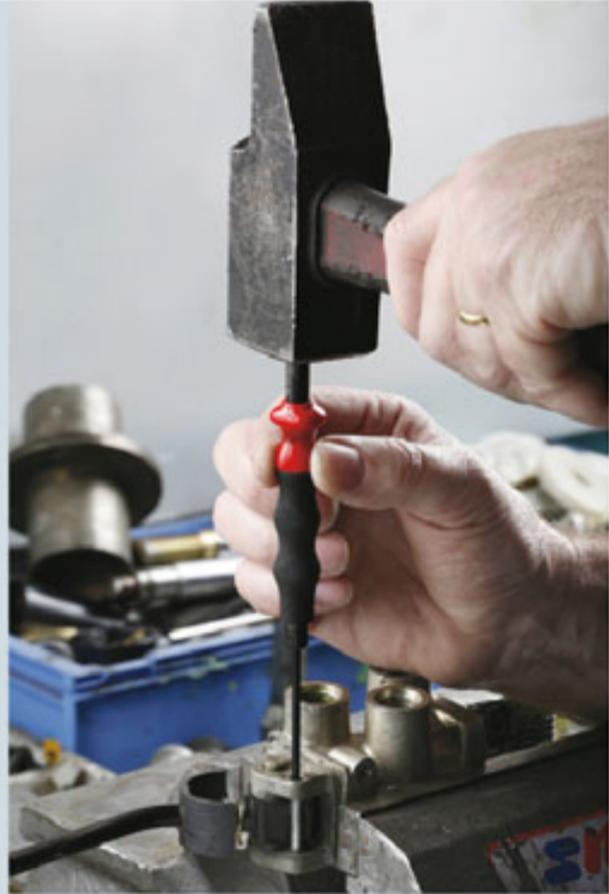
249G Sheathed drift punches

- Long shank.
- Head hardened to 43 HRc.
- Shank hardened to 58 HRc.

⇒	Ø A mm	Ø B mm	I mm	L mm	C mm	ΔΔ g
249.G2	1,95	8	35	140	105	88
249.G3	2,95	8	45	150	105	90
249.G4	3,95	10	60	190	105	94
249.G5	4,95	10	70	200	105	98
249.G6	5,90	12	80	210	105	142
249.G8	7,90	12	86	216	105	158
249.G10	9,80	14	100	230	105	181
249.G12	11,80	16	130	280	105	380
249.G14	13,80	18	140	290	105	490
249.G16	15,70	18	160	310	105	580

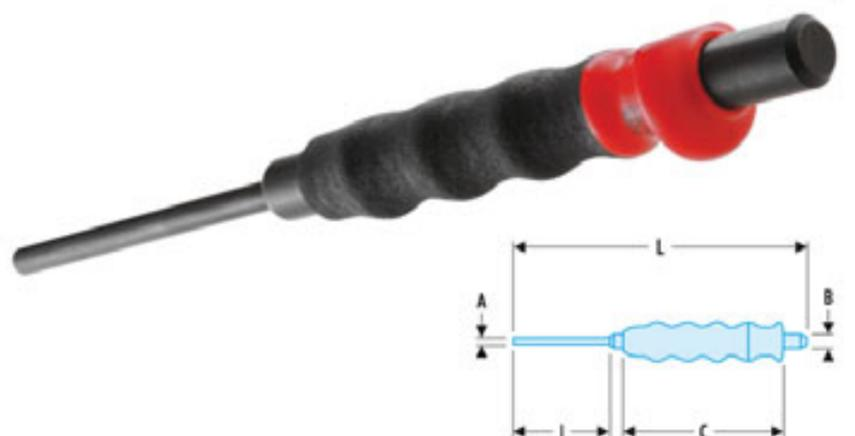

247G Sheathed nail sets

- Head hardened to 36-44 HRc.
- Tip hardened to 52-60 HRc.

➤	Ø A mm	Ø B mm	l mm	L mm	C mm	ΔΔ g
247.G2	1,9	10	55	185	105	102
247.G3	2,9	10	55	185	105	106
247.G4	3,9	10	55	185	105	109
247.G5	4,9	10	55	185	105	112
247.G6	5,9	10	55	185	105	115
247.G8	7,8	12	55	185	105	173

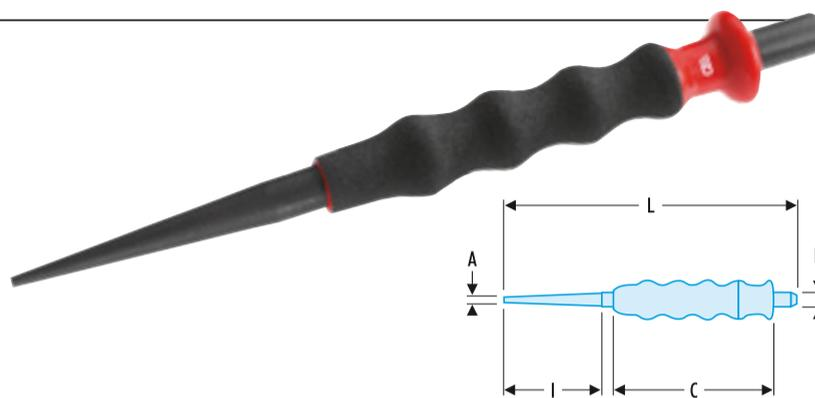

255G Sheathed centre punches

- Head hardened to 36-44 HRc.
- Tip hardened to 57-60 HRc.

➤	Ø A mm	Ø B mm	l mm	L mm	C mm	ΔΔ g
255.G2,5	2,5	10	55	185	105	104
255.G4	4	10	55	185	105	110
255.G6	6	10	55	185	105	116
255.G8	8	12	55	185	105	174
255.G10	10	14	55	185	105	210

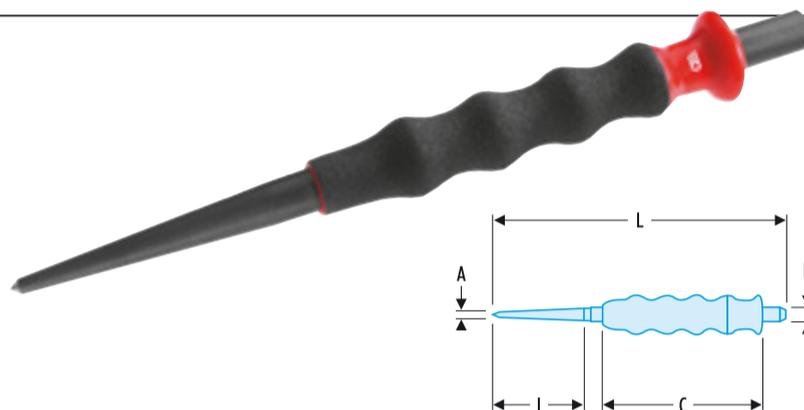

Sets of sheathed impact tools

- Sets of punches and nail sets.

➤	Set contents
249.GJ5	249.G3 - 4 - 5 - 6 - 8
249.GJ7	249.G2 - 3 - 4 - 5 - 6 - 8 - 10
249.G247GJ12	249.G2 - 3 - 4 - 5 - 6 - 8 247.G2 - 3 - 4 - 5 - 6 - 8
249.GJ4	249.G10 - 12 - 14 - 16

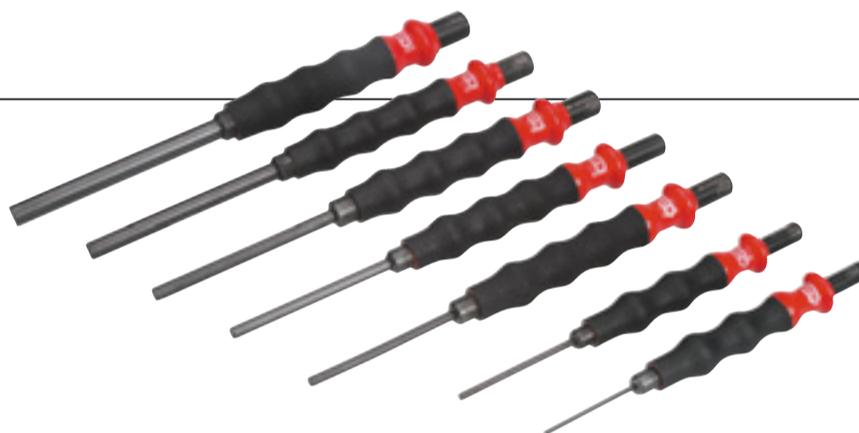

Sheathed drift punch modules

MOD.CG

- 6 drift punches 249G : 2-3-4-5-6-8 mm.
 - 4 nail sets 247G : 4-5-6-8 mm.
 - 1 centre punch 255.G6.
 - Tray PL.330.
- ΔΔ : 1.47 kg.



Foam modules of sheathed drift punches

MODM.CG

- 6 drift punches 249G : 2-3-4-5-6-8 mm.
 - 4 nail sets 247G : 4-5-6-8 mm.
 - 1 centre punch 255.G6.
 - Tray PM.MODCG.
- ΔΔ : 1.47 kg.

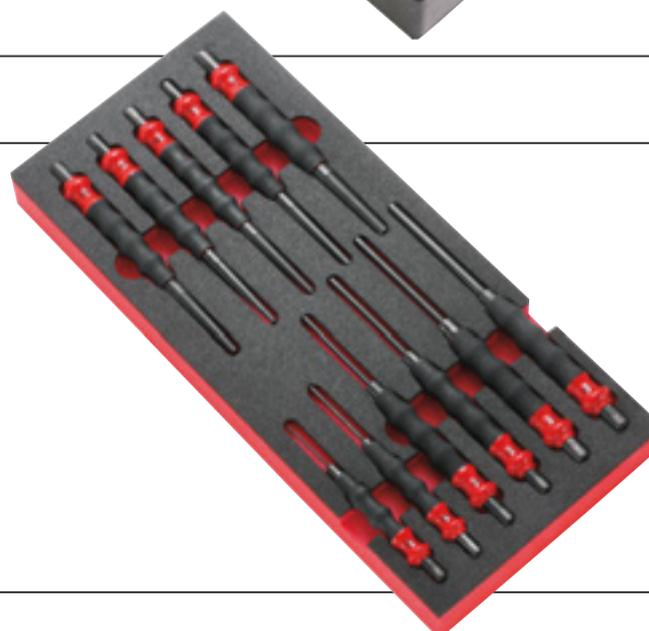

New



Sheathed automatic centre punch

257.G

- Simply press the end to release spring impact.
- Impact adjustable from 15 to 25 kg by turning the end.
- Ergonomic Facom handle.
- Tip hardened to 57-60 HRc.

ΔΔ : 175 g.



263.G Sheathed chisels

- Engineers chisels.
- Hardness :
 - Edge = 57 - 60 HRc
 - Striking head = 36 - 44 HRc.
- Angle of edge : 60°.

	L mm	A mm	Ø B mm	ΔΔ g
263.G19	190	15	12	165
263.G20	200	20	16	305
263.G22	220	25	18	415

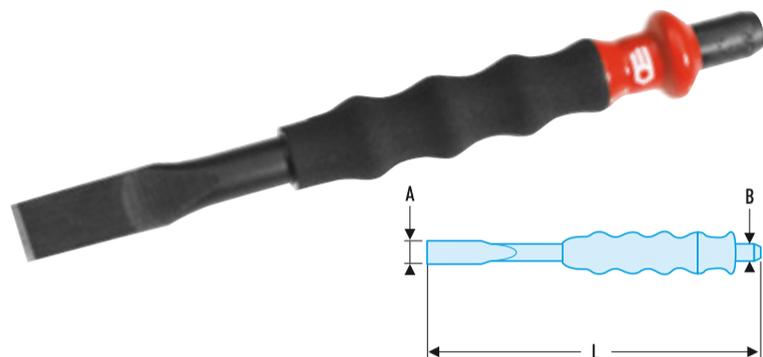

Sheathed cape chisels

265.G18

- Hardness :
 - Edge : 57-60 HRc.
 - Striking head : 36- 44 HRc.

	L mm	A mm	Ø B mm	ΔΔ g
265.G18	180	10	10	110

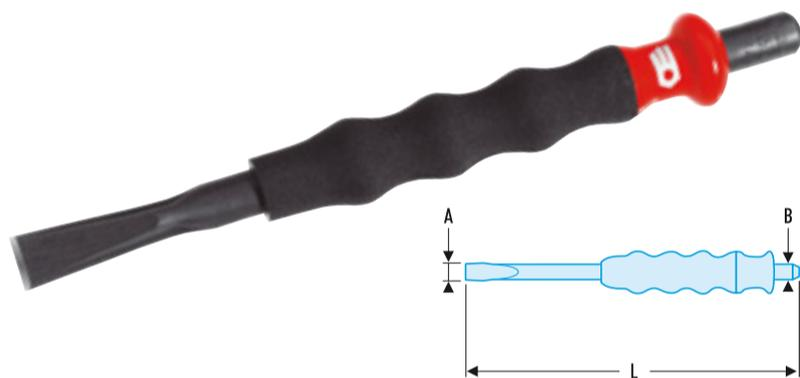

Set of sheathed tools

263.GJ4

- Comprising :
 - Flat chisels 263.G 19, 20, 22 .
 - Cape chisel 265.G18
 - Supplied in a cardboard box.
- ΔΔ : 1.005 kg. D : 1,005 kg.



Sheathed drift punch, flat chisel and cape chisel modules

MOD.CG1

- 249.G 12-14-16 mm.
 - 263.G 19-20-22.
 - 265.G 18.
 - Tray PL.611.
- ΔΔ : 3 kg.



► Drift punches

249 Standard drift punches

- Hexagonal shank, high-strength steel tip, hardened to 52-58 HRc.

⇒	Ø A mm	B mm	l mm	L mm	ΔΔ g
249.2	1,9	8	25	105	30
249.3	2,9	8	30	120	35
249.4	3,9	10	35	135	65
249.5	4,9	10	40	150	75
249.6	5,9	12	45	165	120
249.8	7,9	12	50	180	140
249.10	9,9	16	55	195	170

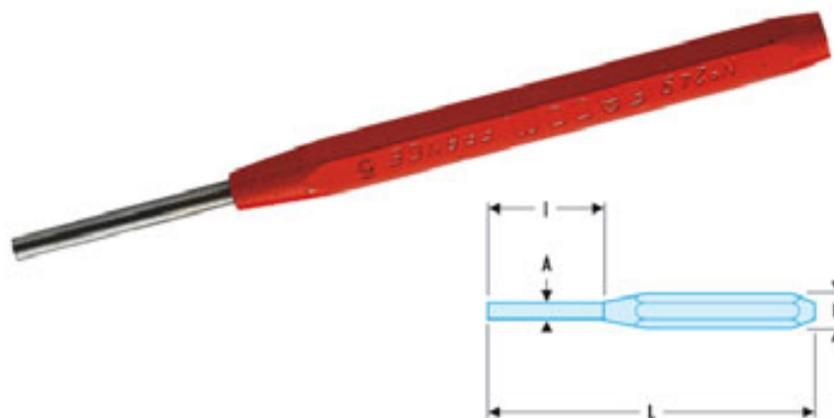

248 Long drift punches

- Hexagonal shank, high-strength steel tip, hardened to 52-58 HRc.

⇒	Ø A mm	B mm	l mm	L mm	ΔΔ g
248.2	1,9	8	35	165	45
248.3	2,9	8	40	170	50
248.4	3,9	8	50	175	55
248.5	4,9	10	55	180	85
248.6	5,9	10	60	185	90
248.8	7,9	12	65	190	135
248.10	9,9	12	75	200	200

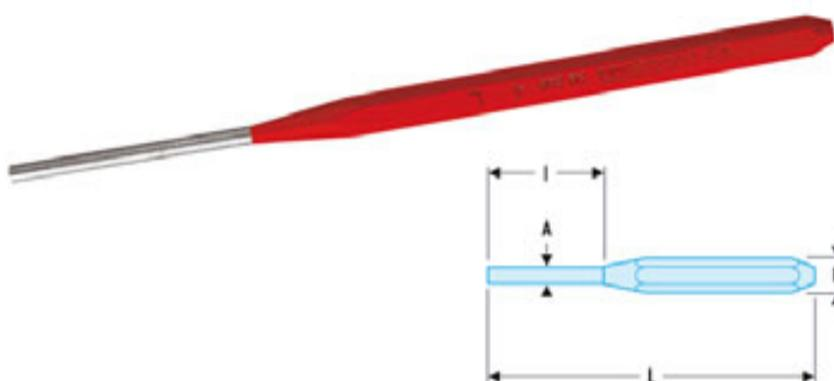

246 Drift punches for spring pins

- Shouldered tip accurately centres into split pins.

⇒	Ø A mm	B mm	Ø C mm	l mm	L mm	ΔΔ g
246.2	1,9	8	1,0	25	105	30
246.3	2,9	8	1,8	30	120	35
246.4	3,9	10	2,4	35	135	45
246.5	4,9	10	3,0	40	150	75
246.6	5,9	12	3,6	45	165	120
246.8	7,9	12	5,1	50	180	140

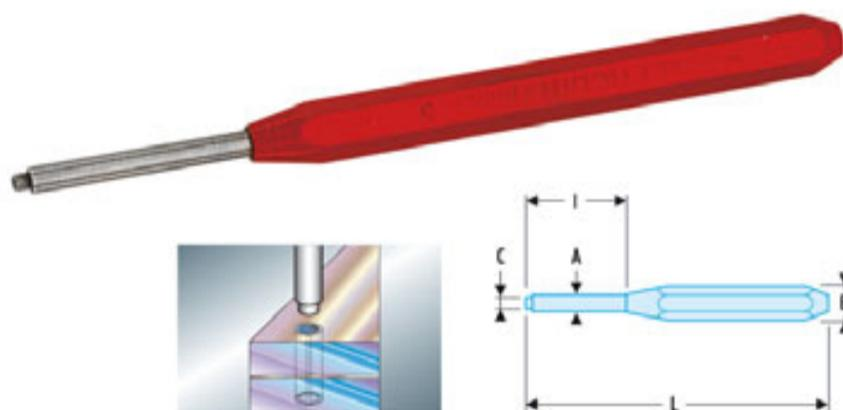

251A Precision sleeved drift punches

- The centre slides within a guide to prevent distortion, even in smaller sizes.
- Nickel shank, polished tip.

⇒	Ø A mm	B mm	l mm	L mm	ΔΔ g
251A.1	0,9	5	12	70	5
251A.1,5	1,4	6	15	80	10
251A.2	1,9	6	18	83	10
251A.2,5	2,4	7	21	92	18
251A.3	2,9	7	24	95	20
251A.3,5	3,4	8	27	97	25
251A.4	3,9	8	30	100	30
251A.5	4,9	10	33	109	45
251A.6	5,9	12	36	112	65

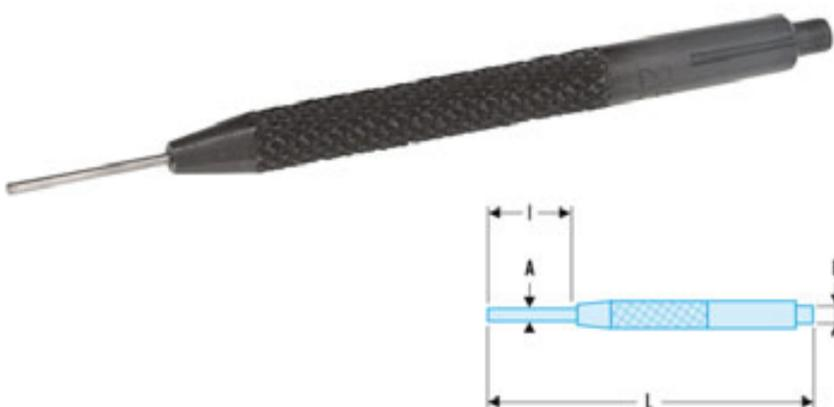

► Nail sets

247 Standard nail sets

- Hexagonal shank, high-strength steel tip, hardened to 40-46 HRC.
- Paint-finish shank, polished tip.

➤	Ø mm	B mm	L mm	l mm	ΔΔ g
247.2	1,6	8	105	40	35
247.3	2,0	8	120	45	40
247.4	2,8	10	135	50	70
247.5	4,0	10	150	55	80
247.6	4,8	12	160	60	120
247.8	7,0	12	180	65	140

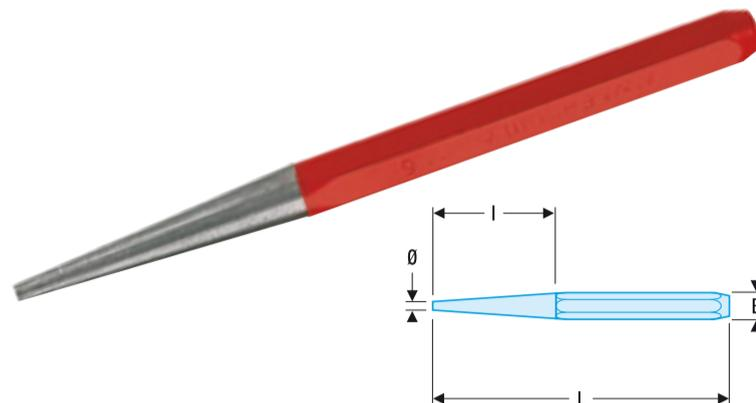

► Centre punches

256 Precision centre punches

- ▷ NF E 71-211.
- Forged in chrome-vanadium steel, hardened to 52-58 HRC.
- Knurled body.
- Chrome finish.

➤	Ø mm	B mm	L mm	ΔΔ g
256.2,5	2,5	7	100	25
256.4	4	8	105	35
256.6	6	10	115	60
256.8	8	12	130	100
256.10	10	14	130	135

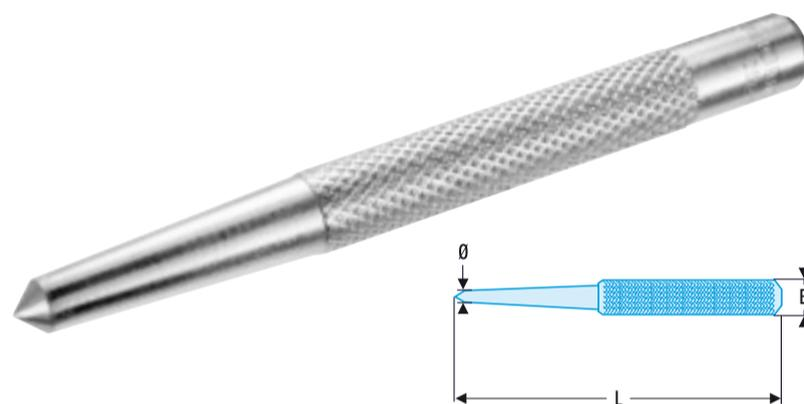

Automatic centre punch

257

- Simply press the end to release spring impact.
 - Impact strength adjusted by turning the knurl.
 - Effective load 11 to 22 kg.
 - Chromed body, greased tip.
 - Length : 140 mm, shank Ø 16 mm, tip Ø 3.5 mm.
- ΔΔ : 135 g.



➤	Description
257.07	Interchangeable tip

► Sets

Punch sets

- JS in rack.
- JT in wallet.
- For 249.JT7 : wallet N.38A-7B.
- For 248.JT7 : wallet N.38A-7B.
- For 251A.JT9 : wallet N.38A-9C.
- For 247.265JT10 : wallet N.38A-10B.

➤	Set contents	L x l x H mm	Stand	ΔΔ kg
249.JS7	249.2-3-4-5-6-8-10	120x195x45	CKS.31A	0,868
249.JT7	249.2-3-4-5-6-8-10	230x120	-	0,755
248.JS6	248.2-3-4-5-6-8	120x190x45	CKS.29A	0,588
248.JT7	248.2-3-4-5-6-8-10	265 x 120	-	0,695
246.JS6	246.2-3-4-5-6-8	120x190x45	CKS.29A	0,593
246.JT6	246.2-3-4-5-6-8	200x165	-	0,545
251A.JS9	251A.1-1.5-2-2.5-3-3.5-4-5-6	120x115x45	CKS.32A	0,354
251A.JT9	251A.1-1.5-2-2.5-3-3.5-4-5-6	180 x 120	-	0,260
247.249JS12	247.2-3-4-5-6-8 / 249.2-3-4-5-6-8	120x180x47	CKS.33A	1,076
247.265JT10	247.3-4-5 / 256.4-6 / 249.3-4-5 / 263.20 / 265.18	180x120 / 240x60	-	1,155



Impact tool module

MOD.MI1

200H.32 Hammer.
208A.32CB Mallet.
263.20 Chisel.
256.6 Centre punch.
248. Long drift punches 4 - 5 - 6 mm.
• Complete with tray PL.333.
ΔΔ : 1.800 kg.



Foam module of impact tools

New

MODM.MI1

200H.40 Hammer.
208A.32CB Mallet.
263.20 Chisel.
256.6 Centre punch.
248. Long drift punches 4 - 5 - 6 mm.
• Complete with tray PM.MODMI1.
ΔΔ : 1.8 kg.

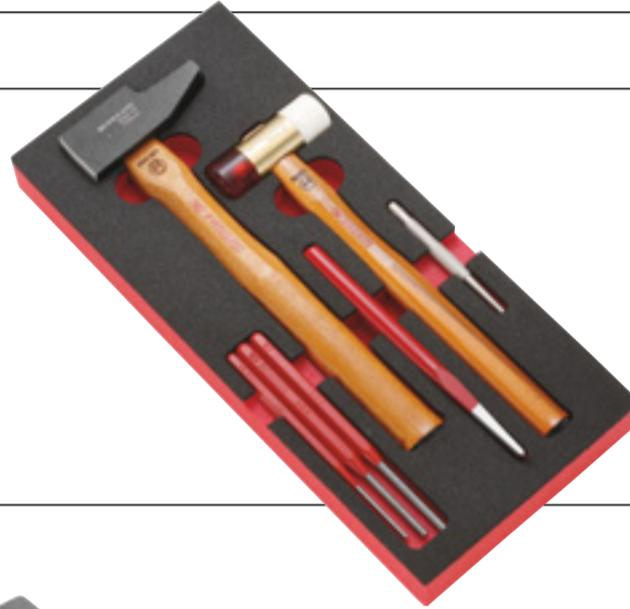

Impact tool module 205

MOD.MI3

205A.50 Hammer.
208A.32CB Mallet.
263.18 Chisel.
256.6 Centre punch.
248. Long drift punches 4 - 5 - 6 mm.
• Complete with tray PL.333.
ΔΔ : 1.710 kg



Foam module of impact tools

New

MODM.MI3

205H.100 Hammer.
208A.32CB Mallet.
263.20 Chisel.
256.6 Centre punch.
248. Long drift punches 4 - 5 - 6 mm.
• Complete with tray PM.MODMI3.
ΔΔ : 1.8 kg.



Impact tool module 202

MOD.MI4

202H.1/2 Hammer.
208A.32CB Mallet.
263.18 Chisel.
256.6 Centre punch.
248. Long drift punches 4 - 5 - 6 mm.
• Complete with tray PL.333.
ΔΔ : 1.45 kg.



New

Foam module of impact tools

MODM.MI4

202.A1 Hammer.
 208A.32CB Mallet.
 263.20 Chisel.
 256.6 Centre punch.
 248. Long drift punches 4 - 5 - 6 mm.

- Complete with tray PM.MODMI4.

ΔΔ : 1.8 kg.



► Flat chisels - Cape chisels

263 Flat chisels - 265 Cape chisels

263 : Constant-profile flat chisels.

263.P : Chisels with guard.

265 : Constant-profile cape chisel.

- Forged in chrome-vanadium steels, tip hardened to 57 HRc.
- Regrindable tip.
- Head treated against mushrooming.
- Paint finish.
- Ø 85 mm guard (263.P).

➤	l mm	L mm	ΔΔ g
263.15	21	150	200
263.18	21	180	250
263.20	24	200	350
263.22	24	220	400
263.25	27	250	520
263.30	27	300	640
263.P25	27	250	610
263.P30	27	300	710
265.18	8	180	240
265.20	10	200	330
265.22	12	220	370

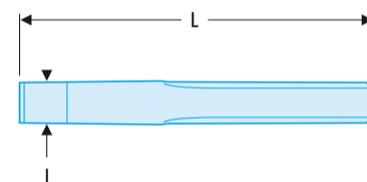

259 Flat chisels

259 : Slim-profile chisel.

259.P : Slim chisel with guard. Ø 85 mm.

- Forged in chrome-vanadium steels, tip hardened to 57 HRc.
- Paint finish.

➤	l mm	L mm	ΔΔ g
259	26	235	240
259.P	26	235	350

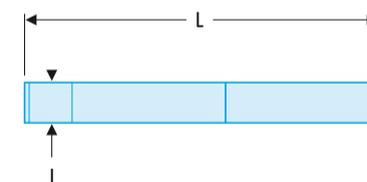
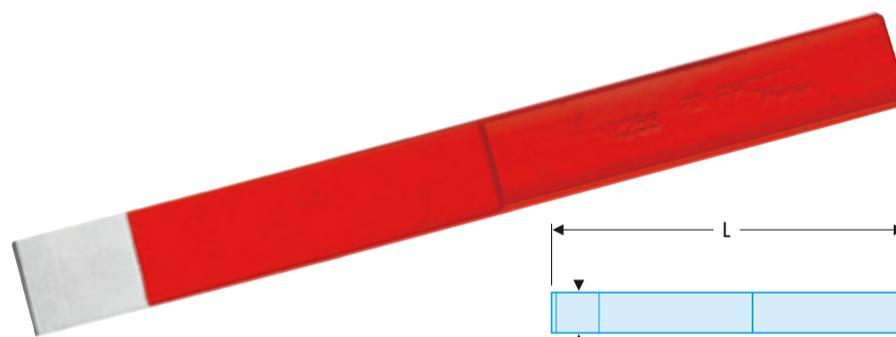

Special chisels

- Forged in chrome-vanadium steels, tip hardened to 57 HRc.
- Regrindable tip.
- Head treated against mushrooming.
- Paint finish.
- Ø 85 mm guard.

➤	l mm	L mm	ΔΔ g
258	25	200	220
260.P	60	250	630

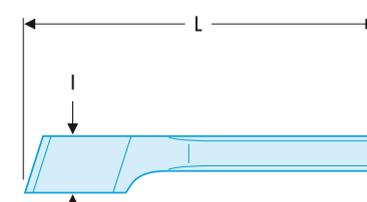
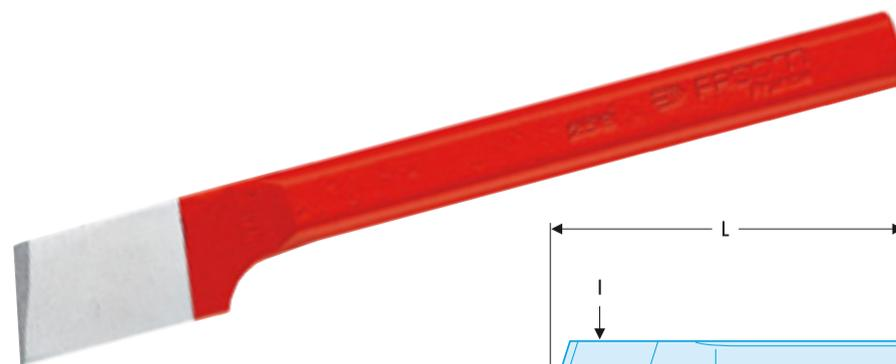

262A Round-headed ribbed chisels

▷ Standard UNI 7506.

- Forged chisel with rounded edges for improved grip.
- Cylindrical head for increased safety.
- Tip hardness 57 to 59 HRc.
- Tip angle 60°.
- Zinc finish.

➤	L mm	l mm	A mm	ΔΔ g
262A.15	150	21	16	170
262A.18	180	24	18	250
262A.20	200	26	18	340
262A.25	260	29	21	500

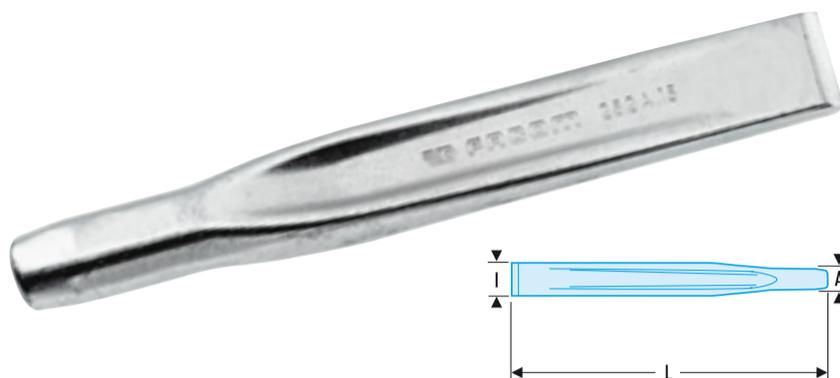

Precision chisels

252 : Precision flat chisel.

254A : Precision cape chisels.

- Knurled body.

➤	l mm	L mm	ΔΔ g
252.8	10	115	40
252.10	12	125	70
254A.8	8	115	40
254A.10	10	120	60

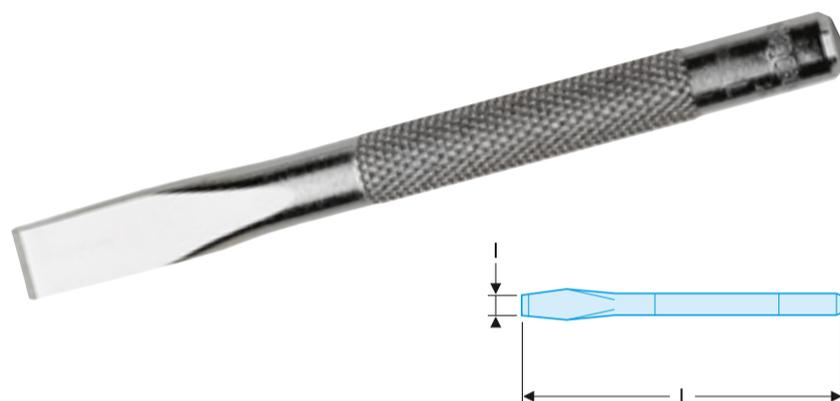

Chisel sets

➤	Set contents	L x l x H mm	Stand	ΔΔ kg
263.265JS5	263.15-20-25 265.18-22	255 x 180 x 30	CKS.81A	1,85
252.254JS4	252.8-10 254A.8-10	120 x 180 x 25	CKS.28A	0,27



Chisel sets

262A.JS4

For your safety :

- Always check the state of your tools before use.
- Do not use tools showing signs of wear, mushrooming, chipping or cracking.
- Wear eye protection and gloves.

➤	Set contents	L x l x H mm	Stand	ΔΔ kg
262A.JS4	262A.15-18-20-25	180 x 30 x 250	CKS.80B	1,44

