

## LM5025 Active Clamp Voltage Mode PWM Controller

### 1 Features

- Internal Start-Up Bias Regulator
- 3-A Compound Main Gate Driver
- Programmable Line Undervoltage Lockout (UVLO) With Adjustable Hysteresis
- Voltage Mode Control With Feed-Forward
- Adjustable Dual-Mode Overcurrent Protection
- Programmable Overlap or Deadtime Between the Main and Active Clamp Outputs
- Volt × Second Clamp
- Programmable Soft-Start
- Leading Edge Blanking
- Single Resistor Programmable Oscillator
- Oscillator UP and DOWN Sync Capability
- Precision 5-V Reference
- Thermal Shutdown

### 2 Applications

- Server Power Supplies
- 48-V Telecom Power Supplies
- 42-V Automotive Applications
- High-Efficiency DC-to-DC Power Supplies

### 3 Description

The LM5025 PWM controller contains all of the features necessary to implement power converters using the active clamp and reset technique. The device can be configured to control either a P-channel clamp switch or an N-channel clamp switch. With the active clamp technique, higher efficiencies and greater power densities can be realized compared to conventional catch winding or RDC clamp and reset techniques.

Two control outputs are provided, the main power switch control (OUT\_A), and the active clamp switch control (OUT\_B). The active clamp output can be configured for either a specified overlap time (for P-channel switch applications) or a specified deadtime (for N-channel applications). The two internal compound gate drivers parallel both MOS and bipolar devices, providing superior gate drive characteristics. This controller is designed for high-speed operation including an oscillator frequency range up to 1 MHz and total PWM and current sense propagation delays less than 100 ns.

The LM5025 includes a high-voltage start-up regulator that operates over a wide input range of 13 V to 90 V. Additional features include: line undervoltage lockout (UVLO), soft-start, oscillator UP and DOWN sync capability, precision reference and thermal shutdown.

#### Device Information<sup>(1)</sup>

PART NUMBER	PACKAGE	BODY SIZE (NOM)
LM5025	TSSOP (16)	5.00 mm × 4.40 mm
	WSON (16)	5.00 mm × 5.00 mm

(1) For all available packages, see the orderable addendum at the end of the data sheet.

#### Simplified Schematic

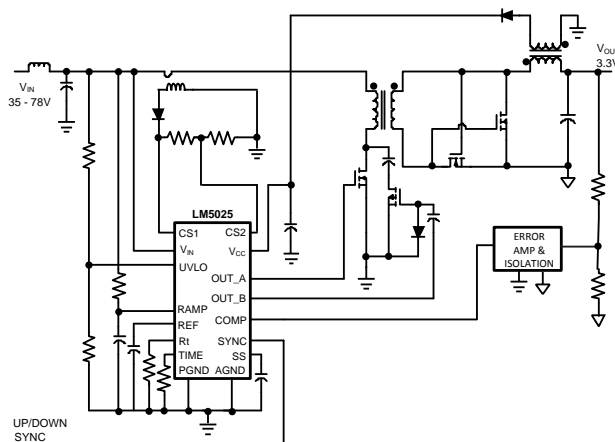

## Table of Contents

<b>1 Features</b> .....	<b>1</b>	7.4 Device Functional Modes.....	<b>16</b>
<b>2 Applications</b> .....	<b>1</b>	<b>8 Application and Implementation</b> .....	<b>17</b>
<b>3 Description</b> .....	<b>1</b>	8.1 Application Information.....	<b>17</b>
<b>4 Revision History</b> .....	<b>2</b>	8.2 Typical Application .....	<b>17</b>
<b>5 Pin Configuration and Functions</b> .....	<b>3</b>	<b>9 Power Supply Recommendations</b> .....	<b>23</b>
<b>6 Specifications</b> .....	<b>4</b>	<b>10 Layout</b> .....	<b>23</b>
6.1 Absolute Maximum Ratings .....	4	10.1 Layout Guidelines .....	23
6.2 ESD Ratings.....	4	10.2 Layout Example .....	23
6.3 Recommended Operating Conditions.....	4	<b>11 Device and Documentation Support</b> .....	<b>24</b>
6.4 Thermal Information .....	5	11.1 Documentation Support .....	24
6.5 Electrical Characteristics.....	5	11.2 Community Resources.....	24
6.6 Typical Characteristics.....	8	11.3 Trademarks .....	24
<b>7 Detailed Description</b> .....	<b>10</b>	11.4 Electrostatic Discharge Caution.....	24
7.1 Overview .....	10	11.5 Glossary .....	24
7.2 Functional Block Diagram .....	11	<b>12 Mechanical, Packaging, and Orderable</b>	
7.3 Feature Description.....	12	<b>Information</b> .....	<b>24</b>

## 4 Revision History

NOTE: Page numbers for previous revisions may differ from page numbers in the current version.

### Changes from Revision B (March 2013) to Revision C

Page

- Added *ESD Ratings* table, *Feature Description* section, *Device Functional Modes*, *Application and Implementation* section, *Power Supply Recommendations* section, *Layout* section, *Device and Documentation Support* section, and *Mechanical, Packaging, and Orderable Information* section ..... **1**

## 5 Pin Configuration and Functions

**PW and NHQ Packages  
16-Pin TSSOP and WSON  
Top View**

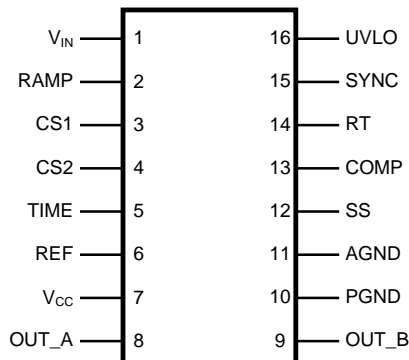

**Pin Functions**

PIN		I/O <sup>(1)</sup>	DESCRIPTION	APPLICATION INFORMATION
NO.	NAME			
1	V <sub>IN</sub>	I	Source input voltage	Input to start-up regulator. Input 13 V to 90 V, with transient capability to 100 V.
2	RAMP	I	Modulator ramp signal	An external RC circuit from Vin sets the ramp slope. This pin is discharged at the conclusion of every cycle by an internal FET, initiated by either the internal clock or the V*Sec Clamp comparator.
3	CS1	I	Current sense input for cycle-by-cycle limiting	If CS1 exceeds 0.25 V the outputs goes into Cycle-by-Cycle current limit. CS1 is held low for 50 ns after OUT_A switches high providing leading edge blanking.
4	CS2	I	Current sense input for soft restart	If CS2 exceeds 0.25 V the outputs are disabled and a soft-start commences. The soft-start capacitor is fully discharged and then released with a pullup current of 1 μA. After the first output pulse (when SS = 1 V), the SS charge current reverts back to 20 μA. CS2 is held low for 50 ns after OUT_A switches high, providing leading edge blanking.
5	TIME	I	Output overlap and deadtime control	An external resistor (R <sub>SET</sub> ) sets either the overlap time or dead time for the active clamp output. An R <sub>SET</sub> resistor connected between TIME and GND produces in-phase OUT_A and OUT_B pulses with overlap. An R <sub>SET</sub> resistor connected between TIME and REF produces out-of-phase OUT_A and OUT_B pulses with deadtime.
6	REF	O	Precision 5-V reference output	Maximum output current: 10-mA locally decouple with a 0.1-μF capacitor. Reference stays low until the line UVLO and the V <sub>CC</sub> UV comparators are satisfied.
7	V <sub>CC</sub>	P	Output from the internal high-voltage start-up regulator. The V <sub>CC</sub> voltage is regulated to 7.6 V	If an auxiliary winding raises the voltage on this pin above the regulation setpoint, the internal start-up regulator shutdowns, reducing the IC power dissipation.
8	OUT_A	O	Main output driver	Output of the main switch PWM output gate driver. Output capability of 3-A peak sink current.
9	OUT_B	O	Active clamp output driver	Output of the active clamp switch gate driver. Capable of 1.25-A peak sink current..
10	PGND	G	Power ground	Connect directly to analog ground.
11	AGND	G	Analog ground	Connect directly to power ground. For the WSON package option the exposed pad is electrically connected to AGND.
12	SS	I	Soft-start control	An external capacitor and an internal 20-μA current source set the soft-start ramp. The SS current source is reduced to 1 μA initially following a CS2 overcurrent event or an over temperature event.

(1) P = power, G = ground, I = input, O = Output, I/O = Input/output

**Pin Functions (continued)**

PIN		I/O <sup>(1)</sup>	DESCRIPTION	APPLICATION INFORMATION
NO.	NAME			
13	COMP	I	Input to the pulse width modulator	An internal 5-K $\Omega$ resistor pullup is provided on this pin. The external opto-coupler sinks current from COMP to control the PWM duty cycle.
14	RT	I	Oscillator timing resistor pin	An external resistor connected from RT to ground sets the internal oscillator frequency.
15	SYNC	I	Oscillator UP and DOWN synchronization input	The internal oscillator can be synchronized to an external clock with a frequency 20% lower than the internal oscillator's free running frequency. There is no constraint on the maximum sync frequency.
16	UVLO	I	Line undervoltage shutdown	An external voltage divider from the power source sets the shutdown comparator levels. The comparator threshold is 2.5 V. Hysteresis is set by an internal current source (20 $\mu$ A) that is switched on or off as the UVLO pin potential crosses the 2.5-V threshold.

## 6 Specifications

### 6.1 Absolute Maximum Ratings

 over operating free-air temperature range (unless otherwise noted)<sup>(1)</sup>

		MIN	MAX	UNIT
Input voltage	V <sub>IN</sub> to GND	-0.3	100	V
	V <sub>CC</sub> to GND	-0.3	16	
CS1, CS2 to GND		-0.3	1	V
All other inputs to GND		-0.3	7	V
Junction temperature, T <sub>J</sub>			150	°C
Storage temperature, T <sub>stg</sub>		-55	150	°C

- (1) Stresses beyond those listed under *Absolute Maximum Ratings* may cause permanent damage to the device. These are stress ratings only, which do not imply functional operation of the device at these or any other conditions beyond those indicated under *Recommended Operating Conditions*. Exposure to absolute-maximum-rated conditions for extended periods may affect device reliability.

### 6.2 ESD Ratings

		VALUE	UNIT
V <sub>(ESD)</sub> Electrostatic discharge <sup>(1)</sup>	Human-body model (HBM), per ANSI/ESDA/JEDEC JS01 <sup>(2)</sup>	±2000	V
	Charged-device model (CDM), per JEDEC specification JESD22-C101 <sup>(3)</sup>	±500	

- (1) For detailed information on soldering plastic TSSOP and WSON packages, refer to the Packaging Data Book.  
 (2) JEDEC document JEP155 states that 500-V HBM allows safe manufacturing with a standard ESD control process.  
 (3) JEDEC document JEP157 states that 250-V CDM allows safe manufacturing with a standard ESD control process.

### 6.3 Recommended Operating Conditions

over operating free-air temperature range (unless otherwise noted)

	MIN	NOM	MAX	UNIT
V <sub>IN</sub> voltage	13		90	V
External voltage applied to V <sub>CC</sub>	8		15	V
Operating junction temperature	-40		125	°C

## 6.4 Thermal Information

THERMAL METRIC <sup>(1)</sup>		LM5025		UNIT
		PW (TSSOP)	NHQ (WSON)	
		16-PINS	16-PINS	
R <sub>θJA</sub>	Junction-to-ambient thermal resistance	98.7	30	°C/W
R <sub>θJC(top)</sub>	Junction-to-case (top) thermal resistance	27.8	25.9	°C/W
R <sub>θJB</sub>	Junction-to-board thermal resistance	44.3	9.3	°C/W
ψ <sub>JT</sub>	Junction-to-top characterization parameter	1.2	0.2	°C/W
ψ <sub>JB</sub>	Junction-to-board characterization parameter	43.6	9.5	°C/W
R <sub>θJC(bot)</sub>	Junction-to-case (bottom) thermal resistance	—	2.3	°C/W

(1) For more information about traditional and new thermal metrics, see the *Semiconductor and IC Package Thermal Metrics* application report, [SPRA953](#).

## 6.5 Electrical Characteristics

Specifications are T<sub>J</sub> = 25°C. Unless otherwise specified: V<sub>IN</sub> = 48 V, V<sub>CC</sub> = 10 V, R<sub>T</sub> = 31.3 kΩ, R<sub>SET</sub> = 27.4 kΩ<sup>(1)</sup>

PARAMETER		TEST CONDITIONS		MIN	TYP	MAX	UNIT	
<b>STARTUP REGULATOR</b>								
V <sub>CC Reg</sub>	V <sub>CC</sub> regulation	No load	T <sub>J</sub> = 25°C	7.6		7.9	V	
			T <sub>J</sub> = -40°C to 125°C	7.3				
	V <sub>CC</sub> current limit <sup>(2)</sup>		T <sub>J</sub> = 25°C	25		20	mA	
			T <sub>J</sub> = -40°C to 125°C					
I-V <sub>IN</sub>	Startup regulator leakage (external V <sub>CC</sub> Supply)	V <sub>IN</sub> = 100 V	T <sub>J</sub> = 25°C	165		500	μA	
			T <sub>J</sub> = -40°C to 125°C					
	Shutdown current (lin)	UVLO = 0 V	T <sub>J</sub> = 25°C	350		450	μA	
			T <sub>J</sub> = -40°C to 125°C					
<b>V<sub>CC</sub> SUPPLY</b>								
	V <sub>CC</sub> undervoltage lockout voltage (positive going V <sub>CC</sub> )	T <sub>J</sub> = 25°C	V <sub>CC Reg</sub> – 120 mV		V <sub>CC Reg</sub> – 220 mV		V	
			T <sub>J</sub> = -40°C to 125°C					
	V <sub>CC</sub> undervoltage hysteresis	T <sub>J</sub> = 25°C	1.5		1	2	V	
			T <sub>J</sub> = -40°C to 125°C					
	V <sub>CC</sub> supply current (I <sub>CC</sub> )	C <sub>gate</sub> = 0	T <sub>J</sub> = -40°C to 125°C	4.2			mA	
<b>REFERENCE SUPPLY</b>								
V <sub>REF</sub>	Ref voltage	I <sub>REF</sub> = 0 mA	T <sub>J</sub> = 25°C	5		4.85	5.15	V
			T <sub>J</sub> = -40°C to 125°C					
	Ref voltage regulation	I <sub>REF</sub> = 0 to 10 mA	T <sub>J</sub> = 25°C	25		50	mV	
			T <sub>J</sub> = -40°C to 125°C					
	Ref current limit	T <sub>J</sub> = 25°C	20		10		mA	
			T <sub>J</sub> = -40°C to 125°C					
<b>CURRENT LIMIT</b>								
CS1 Prop	CS1 delay to output	CS1 step from 0 to 0.4 V, Time to onset of OUT transition (90%), C <sub>gate</sub> = 0		40			ns	
CS2 Prop	CS2 delay to output	CS2 step from 0 to 0.4 V, Time to onset of OUT transition (90%), C <sub>gate</sub> = 0		50			ns	
	Leading edge blanking time			50			ns	
	Cycle by cycle threshold voltage (CS1)	T <sub>J</sub> = 25°C	0.25		0.22	0.28	V	
		T <sub>J</sub> = -40°C to 125°C						
	Cycle skip threshold voltage (CS2)	Resets SS capacitor; auto restart	T <sub>J</sub> = 25°C	0.25		0.22	0.28	V
			T <sub>J</sub> = -40°C to 125°C					

- (1) All electrical characteristics having room temperature limits are tested during production with T<sub>A</sub> = T<sub>J</sub> = 25°C. All hot and cold limits are specified by correlating the electrical characteristics to process and temperature variations and applying statistical process control.  
(2) Device thermal limitations may limit usable range.

## Electrical Characteristics (continued)

 Specifications are  $T_J = 25^\circ\text{C}$ . Unless otherwise specified:  $V_{IN} = 48\text{ V}$ ,  $V_{CC} = 10\text{ V}$ ,  $R_T = 31.3\text{ k}\Omega$ ,  $R_{SET} = 27.4\text{ k}\Omega^{(1)}$ 

PARAMETER	TEST CONDITIONS		MIN	TYP	MAX	UNIT
CS sink impedance (clocked)	$I_{CS} = 10\text{ mA}$	$T_J = 25^\circ\text{C}$		30		$\Omega$
		$T_J = -40^\circ\text{C to } 125^\circ\text{C}$			50	
<b>SOFT-START</b>						
Soft-start current source normal	$T_J = 25^\circ\text{C}$			22		$\mu\text{A}$
	$T_J = -40^\circ\text{C to } 125^\circ\text{C}$		17		27	
Soft-start current source following a CS2 event	$T_J = 25^\circ\text{C}$			1		$\mu\text{A}$
	$T_J = -40^\circ\text{C to } 125^\circ\text{C}$		0.5		1.5	
<b>OSCILLATOR</b>						
Frequency1	$T_J = 25^\circ\text{C}$		180	200	220	kHz
	$T_J = -40^\circ\text{C to } 125^\circ\text{C}$		175		225	
Frequency2	$R_T = 10.4\text{ k}\Omega$	$T_J = 25^\circ\text{C}$		580		kHz
		$T_J = -40^\circ\text{C to } 125^\circ\text{C}$	500		660	
Sync frequency	$T_J = -40^\circ\text{C to } 125^\circ\text{C}$		160			kHz
Sync threshold				2		V
Minimum sync pulse width	$T_J = -40^\circ\text{C to } 125^\circ\text{C}$				100	ns
<b>PWM COMPARATOR</b>						
Delay to output	COMP step 5 V to 0 V, Time to onset of OUT_A transition low			40		ns
Duty cycle	$T_J = -40^\circ\text{C to } 125^\circ\text{C}$		0%		80%	
COMP to PWM offset	$T_J = 25^\circ\text{C}$			1		V
	$T_J = -40^\circ\text{C to } 125^\circ\text{C}$		0.7		1.3	
COMP open circuit voltage	$T_J = -40^\circ\text{C to } 125^\circ\text{C}$		4.3		5.9	V
COMP short circuit current	COMP = 0 V	$T_J = 25^\circ\text{C}$		1		mA
		$T_J = -40^\circ\text{C to } 125^\circ\text{C}$	0.6		1.4	
<b>VOLT x SECOND CLAMP</b>						
Ramp clamp level	Delta RAMP measured from onset of OUT_A to Ramp peak, COMP = 5 V	$T_J = 25^\circ\text{C}$		2.5		V
		$T_J = -40^\circ\text{C to } 125^\circ\text{C}$	2.4		2.6	
<b>UVLO SHUTDOWN</b>						
Undervoltage shutdown threshold	$T_J = 25^\circ\text{C}$			2.5		V
	$T_J = -40^\circ\text{C to } 125^\circ\text{C}$		2.44		2.56	
Undervoltage shutdown hysteresis	$T_J = 25^\circ\text{C}$			20		$\mu\text{A}$
	$T_J = -40^\circ\text{C to } 125^\circ\text{C}$		16		24	
<b>OUTPUT SECTION</b>						
OUT_A high saturation	MOS device at $I_{out} = -10\text{ mA}$	$T_J = 25^\circ\text{C}$		5		$\Omega$
		$T_J = -40^\circ\text{C to } 125^\circ\text{C}$			10	
OUT_A low saturation	MOS device at $I_{out} = 10\text{ mA}$	$T_J = 25^\circ\text{C}$		6		$\Omega$
		$T_J = -40^\circ\text{C to } 125^\circ\text{C}$			9	
OUT_B high saturation	MOS device at $I_{out} = -10\text{ mA}$	$T_J = 25^\circ\text{C}$		10		$\Omega$
		$T_J = -40^\circ\text{C to } 125^\circ\text{C}$			20	
OUT_B low saturation	MOS device at $I_{out} = 10\text{ mA}$	$T_J = 25^\circ\text{C}$		12		$\Omega$
		$T_J = -40^\circ\text{C to } 125^\circ\text{C}$			18	
OUTPUT_B peak current sink	Bipolar device at $V_{CC}/2$			1		A
OUTPUT_A peak current sink	Bipolar device at $V_{CC}/2$			3		A
OUTPUT_A rise time	$C_{gate} = 2.2\text{ nF}$			20		ns
OUTPUT_A fall time	$C_{gate} = 2.2\text{ nF}$			15		ns
OUTPUT_B rise time	$C_{gate} = 1\text{ nF}$			20		ns
OUTPUT_B fall time	$C_{gate} = 1\text{ nF}$			15		ns

## Electrical Characteristics (continued)

Specifications are  $T_J = 25^\circ\text{C}$ . Unless otherwise specified:  $V_{IN} = 48\text{ V}$ ,  $V_{CC} = 10\text{ V}$ ,  $R_T = 31.3\text{ k}\Omega$ ,  $R_{SET} = 27.4\text{ k}\Omega^{(1)}$

PARAMETER	TEST CONDITIONS	MIN	TYP	MAX	UNIT
<b>OUTPUT TIMING CONTROL</b>					
Overlap time	$R_{SET} = 38\text{ k}\Omega$ connected to GND, 50% to 50% transitions	$T_J = 25^\circ\text{C}$	105		ns
		$T_J = -40^\circ\text{C}$ to $125^\circ\text{C}$	75	135	
Deadtime	$R_{SET} = 29.5\text{ k}\Omega$ connected to REF, 50% to 50% transitions	$T_J = 25^\circ\text{C}$	105		ns
		$T_J = -40^\circ\text{C}$ to $125^\circ\text{C}$	75	135	
<b>THERMAL SHUTDOWN</b>					
$T_{SD}$	Thermal shutdown threshold	165		$^\circ\text{C}$	
	Thermal shutdown hysteresis	25		$^\circ\text{C}$	

### 6.6 Typical Characteristics

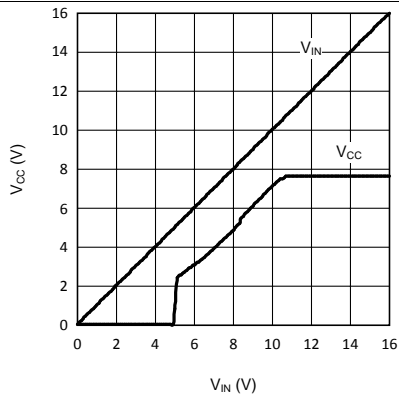

Figure 1.  $V_{CC}$  Regulator Start-Up Characteristics,  $V_{CC}$  vs  $V_{IN}$

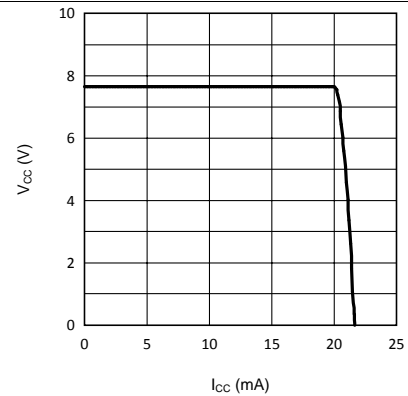

Figure 2.  $V_{CC}$  vs  $I_{CC}$

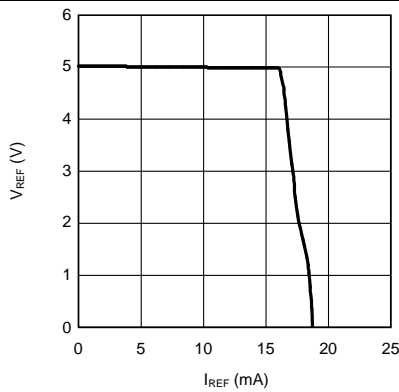

Figure 3.  $V_{REF}$  vs  $I_{REF}$

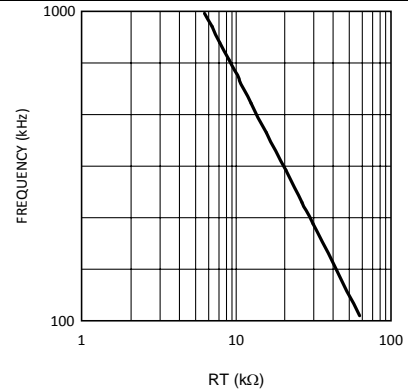

Figure 4. Oscillator Frequency vs  $R_T$

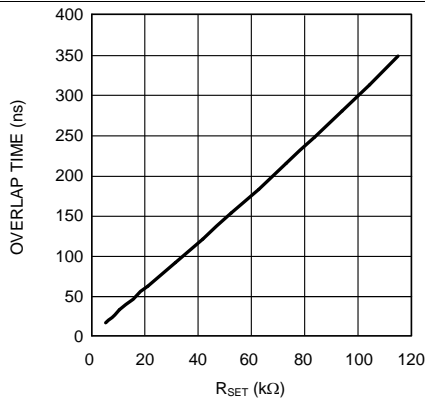

Figure 5. Overlap Time vs  $R_{SET}$

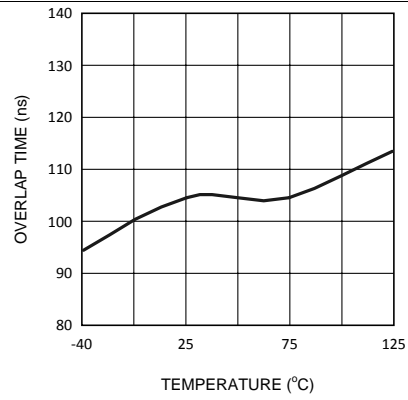
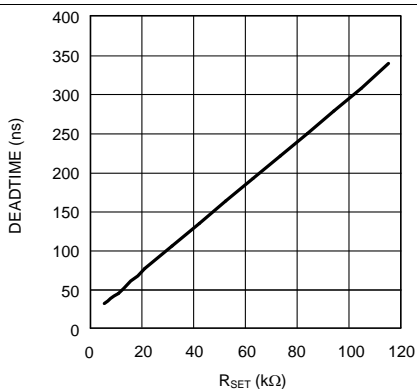

Figure 6. Overlap Time vs Temperature  $R_{SET} = 38\text{ K}$



**Typical Characteristics (continued)**



**Figure 7. Dead Time vs RSET**

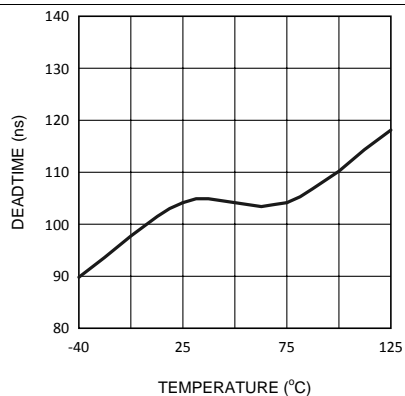

**Figure 8. Dead Time vs Temperature RSET = 29.5 K**

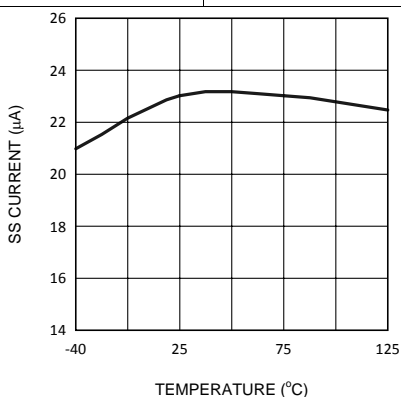

**Figure 9. SS Pin Current vs Temperature**

## 7 Detailed Description

### 7.1 Overview

The LM5025 PWM controller contains all of the features necessary to implement power converters using the active clamp reset technique. The device can be configured to control either a P-channel clamp switch or an N-channel clamp switch. With the active clamp technique higher efficiencies and greater power densities can be realized compared to conventional catch winding or RDC clamp and reset techniques. Two control outputs are provided, the main power switch control (OUT\_A), and the active clamp switch control (OUT\_B). The active clamp output can be configured for either a specified overlap time (for P-channel switch applications) or a specified dead time (for N\_channel applications). The two internal compound gate drivers parallel both MOS and bipolar devices, providing superior gate-drive characteristics. This controller is designed for high-speed operation including an oscillator frequency range up to 1 MHz and total PWM and current sense propagation delays less than 100 ns. The LM5025 includes a high-voltage start-up regulator that operates over a wide input of 13 V to 90 V. Additional features include: line undervoltage lockout (UVLO), soft-start, oscillator UP and DOWN sync capability, precision reference and thermal shutdown.

## 7.2 Functional Block Diagram

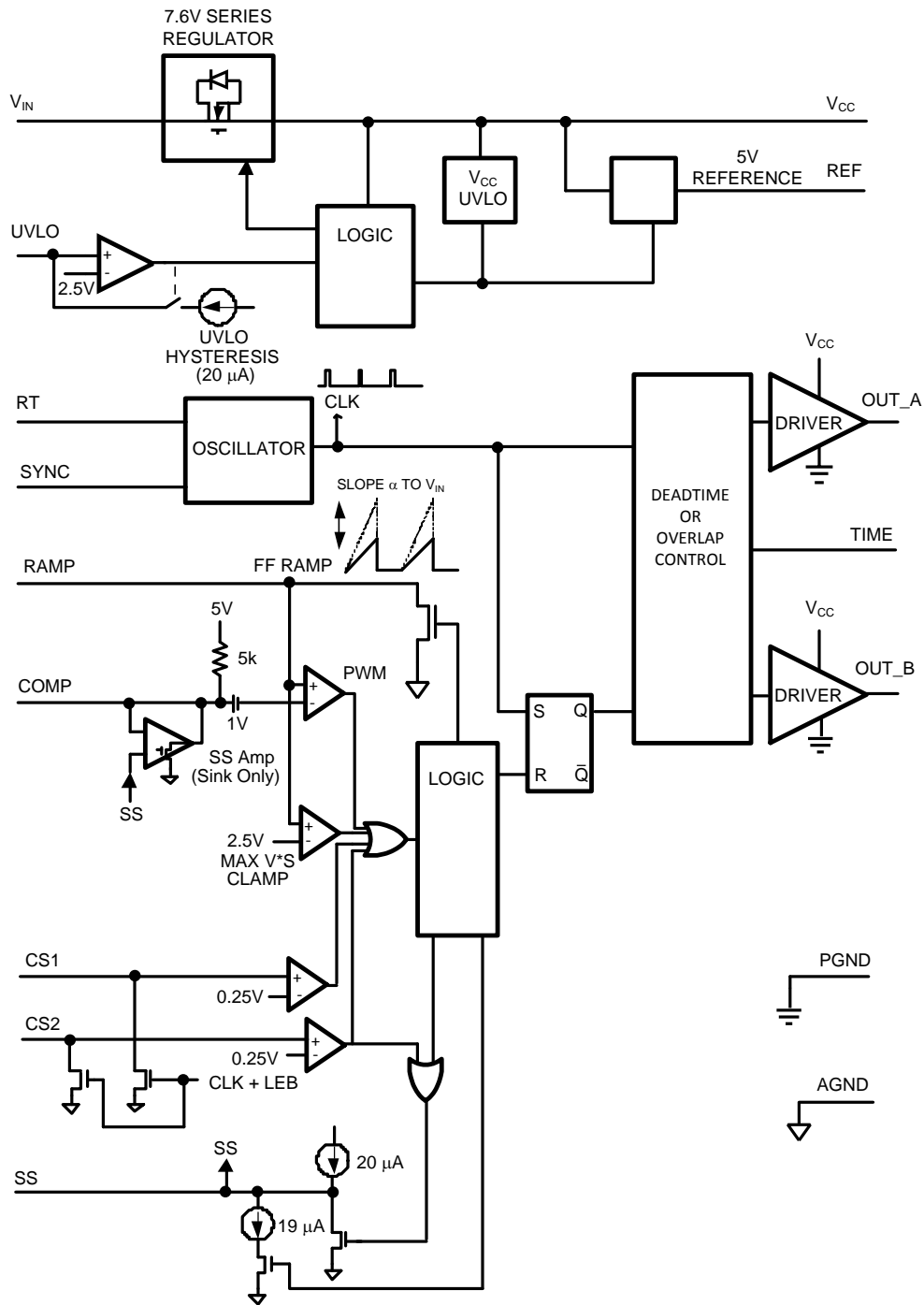

## 7.3 Feature Description

### 7.3.1 High-Voltage Start-Up Regulator

The LM5025 contains an internal high-voltage start-up regulator that allows the input pin ( $V_{IN}$ ) to be connected directly to the line voltage. The regulator output is internally current limited to 20 mA. When power is applied, the regulator is enabled and sources current into an external capacitor connected to the  $V_{CC}$  pin. The recommended capacitance for the  $V_{CC}$  regulator is 0.1  $\mu$ F to 100  $\mu$ F. When the voltage on the  $V_{CC}$  pin reaches the regulation point of 7.6 V and the internal voltage reference (REF) reaches its regulation point of 5 V, the controller outputs are enabled. The outputs remain enabled until  $V_{CC}$  falls below 6.2 V or the line undervoltage lock out detector indicates that  $V_{IN}$  is out of range. In typical applications, an auxiliary transformer winding is connected through a diode to the  $V_{CC}$  pin. This winding must raise the  $V_{CC}$  voltage above 8 V to shut off the internal start-up regulator. Powering  $V_{CC}$  from an auxiliary winding improves efficiency while reducing the controller power dissipation.

The external  $V_{CC}$  capacitor must be sized such that the capacitor and  $V_{CC}$  self-bias maintains a  $V_{CC}$  voltage greater than 6.2 V during the initial start-up. During a fault mode when the converter auxiliary winding is inactive, external current draw on the  $V_{CC}$  line must be limited so the power dissipated in the start-up regulator does not exceed the maximum power dissipation of the controller.

An external start-up regulator or other bias rail can be used instead of the internal start-up regulator by connecting the  $V_{CC}$  and the  $V_{IN}$  pins together and feeding the external bias voltage into the two pins.

### 7.3.2 Line Undervoltage Detector

The LM5025 contains a line undervoltage lock out (UVLO) circuit. An external set-point voltage divider from  $V_{in}$  to GND, sets the operational range of the converter. The divider must be designed such that the voltage at the UVLO pin is greater than 2.5 V when  $V_{in}$  is in the desired operating range. If the undervoltage threshold is not met, all functions of the controller are disabled and the controller remains in a low-power standby state. UVLO hysteresis is accomplished with an internal 20- $\mu$ A current source that is switched on or off into the impedance of the set-point divider. When the UVLO threshold is exceeded, the current source is activated to instantly raise the voltage at the UVLO pin. When the UVLO pin voltage falls below the 2.5-V threshold, the current source is turned off, causing the voltage at the UVLO pin to fall. The UVLO pin can also be used to implement a remote enable and disable function. Pulling the UVLO pin below the 2.5-V threshold disables the converter.

### 7.3.3 PWM Outputs

The relative phase of the main (OUT\_A) and active clamp outputs (OUT\_B) can be configured for the specific application. For active clamp configurations using a ground referenced P-channel clamp switch, the two outputs must be in phase with the active clamp output overlapping the main output. For active clamp configurations using a high side N-channel switch, the active clamp output must be out of phase with main output and there must be a dead time between the two gate drive pulses. A distinguishing feature of the LM5025 is the ability to accurately configure either dead time (both off) or overlap time (both on) of the gate driver outputs. The overlap and deadtime magnitude is controlled by the resistor value connected to the TIME pin of the controller. The opposite end of the resistor can be connected to either REF for deadtime control or GND for overlap control. The internal configuration detector senses the connection and configures the phase relationship of the main and active clamp outputs.

### 7.3.4 Compound Gate Drivers

The LM5025 contains two unique compound gate drivers, which parallel both MOS and bipolar devices to provide high-drive current throughout the entire switching event. The bipolar device provides most of the drive current capability and provides a relatively constant sink current that is ideal for driving large power MOSFETs. As the switching event nears conclusion and the bipolar device saturates, the internal MOS device continues to provide a low-impedance to complete the switching event.

During turnoff at the Miller plateau region, typically around 2 V to 3 V, is where gate driver current capability is needed most. The resistive characteristics of all MOS gate drivers are adequate for turnon, because the supply to output voltage differential is fairly large at the Miller region. During turnoff however, the voltage differential is small and the current source characteristic of the bipolar gate driver is beneficial to provide fast drive capability.

## Feature Description (continued)

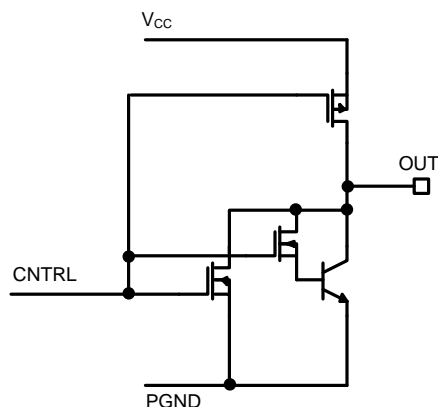

Figure 10. Compound Gate Drivers

### 7.3.5 PWM Comparator

The PWM comparator compares the ramp signal (RAMP) to the loop error signal (COMP). This comparator is optimized for speed to achieve minimum controllable duty cycles. The internal 5-k $\Omega$  pullup resistor, connected between the internal 5-V reference and COMP can be used as the pullup for an optocoupler. The comparator polarity is such that 0 V on the COMP pin produces a zero-duty cycle on both gate driver outputs.

### 7.3.6 Volt Second Clamp

The volt  $\times$  second clamp comparator compares the ramp signal (RAMP) to a fixed 2.5-V reference. By proper selection of RFF and CFF, the maximum ON time of the main switch can be set to the desired duration. The ON time set by volt  $\times$  second clamp varies inversely with the line voltage because the RAMP capacitor is charged by a resistor connected to Vin while the threshold of the clamp is a fixed voltage (2.5 V).

The C<sub>FF</sub> ramp capacitor is discharged at the conclusion of every cycle by an internal discharge switch controlled by either the internal clock or by the V  $\times$  S Clamp comparator, whichever event occurs first.

### 7.3.7 Current Limit

The LM5025 contains two modes of overcurrent protection. If the sense voltage at the CS1 input exceeds 0.25 V the present power cycle is terminated (cycle-by-cycle current limit). If the sense voltage at the CS2 input exceeds 0.25 V, the controller terminates the present cycle, discharge the soft-start capacitor and reduce the soft-start current source to 1  $\mu$ A. The soft-start (SS) capacitor is released after being fully discharged and slowly charges with a 1- $\mu$ A current source. When the voltage at the SS pin reaches approximately 1 V, the PWM comparator produces the first output pulse at OUT\_A. After the first pulse occurs, the soft-start current source reverts to the normal 20- $\mu$ A level. Fully discharging and then slowly charging the SS capacitor protects a continuously overloaded converter with a low-duty cycle hiccup mode.

These two modes of overcurrent protection allows the user great flexibility to configure the system behavior in overload conditions. If it is desired for the system to act as a current source during an overload, then the CS1 cycle-by-cycle current limiting must be used. In this case the current sense signal must be applied to the CS1 input and the CS2 input must be grounded. If during an overload condition it is desired for the system to briefly shutdown, followed by soft-start retry, then the CS2 hiccup current limiting mode must be used. In this case the current sense signal must be applied to the CS2 input and the CS1 input must be grounded. This shutdown and soft-start retry repeats indefinitely while the overload condition remains. The hiccup mode greatly reduces the thermal stresses to the system during heavy overloads. The cycle-by-cycle mode has higher system thermal dissipations during heavy overloads, but provides the advantage of continuous operation for short duration overload conditions.

## Feature Description (continued)

In some systems it is possible use both modes concurrently, whereby slight overload conditions activate the CS1 cycle-by cycle mode, while more severe overloading activates the CS2 hiccup mode. Operating both modes concurrently requires that the slope of the inductor current be sufficient to reach the CS2 threshold before the CS1 function turns off the main output switch. This requires a high  $dv/dt$  at the current sense pin. The signal must be fast enough to reach the second-level threshold before the first threshold detector (CS1) turns off the gate driver. Excessive filtering on the CS pin, an extremely low-value current sense resistor or an inductor that does not saturate with excessive loading may prevent the second-level threshold from ever being reached.

TI recommends a small RC filter, located near the controller, for each of the CS pins. Each CS input has an internal FET that discharges the current sense filter capacitor at the conclusion of every cycle, to improve dynamic performance. This same FET remains on an additional 50 ns at the start of each main switch cycle to attenuate the leading edge spike in the current sense signal.

The LM5025 CS comparators are very fast and may respond to short duration noise pulses. Layout considerations are critical for the current sense filter and sense resistor. The capacitor associated with the CS filter must be placed very close to the device and connected directly to the pins of the IC (CS and GND). If a current sense transformer is used, both leads of the transformer secondary must be routed to the filter network, which must be located close to the IC. If a sense resistor in the source of the main switch MOSFET is used for current sensing, a low-inductance type of resistor is required. When designing with a current sense resistor, all of the noise sensitive low-power ground connections must be connected together near the IC GND and a single connection must be made to the power ground (sense resistor ground point).

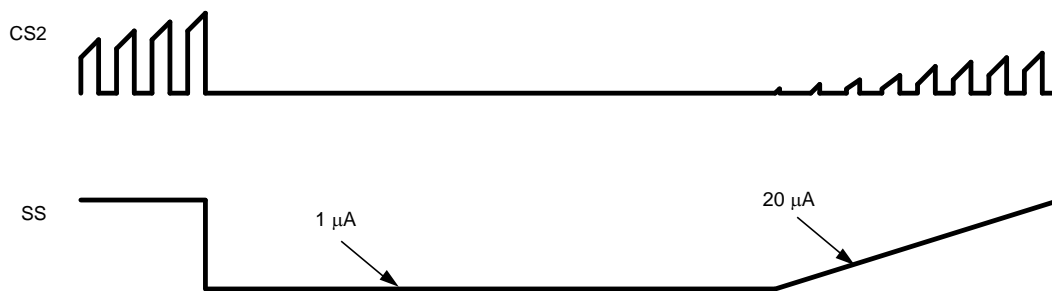

**Figure 11. Current Limit**

### 7.3.8 Oscillator and Sync Capability

The LM5025 oscillator is set by a single external resistor connected between the RT pin and GND.

The RT resistor must be located very close to the device and connected directly to the pins of the IC (RT and GND).

A unique feature of LM5025 is the ability to synchronize the oscillator to an external clock with a frequency that is either higher or lower than the frequency of the internal oscillator. The lower frequency sync frequency range is 80% of the free running internal oscillator frequency. There is no constraint on the maximum SYNC frequency. A minimum pulse width of 100 ns is required for the synchronization clock. If the synchronization feature is not required, the SYNC pin must be connected to GND to prevent any abnormal interference. The internal oscillator can be completely disabled by connecting the RT pin to REF. Once disabled, the sync signal acts directly as the master clock for the controller. Both the frequency and the maximum duty cycle of the PWM controller can be controlled by the SYNC signal (within the limitations of the volt × second clamp). The maximum duty cycle (D) is (1D) of the SYNC signal.

## Feature Description (continued)

### 7.3.9 Feed-Forward Ramp

An external resistor ( $R_{FF}$ ) and capacitor ( $C_{FF}$ ) connected to  $V_{IN}$  and GND are required to create the PWM ramp signal. The slope of the signal at the RAMP pin varies in proportion to the input line voltage. This varying slope provides line feedforward information necessary to improve line transient response with voltage mode control. The RAMP signal is compared to the error signal at the COMP pin by the pulse width modulator comparator to control the duty cycle of the main switch output. The volt second clamp comparator also monitors the RAMP pin and if the ramp amplitude exceeds 2.5 V the present cycle is terminated. The ramp signal is reset to GND at the end of each cycle by either the internal clock or the volt second comparator, whichever occurs first.

### 7.3.10 Soft-Start

The soft-start feature allows the power converter to gradually reach the initial steady state operating point, thus reducing start-up stresses and surges. At power on, a 20- $\mu$ A current is sourced out of the soft-start pin (SS) into an external capacitor. The capacitor voltage ramps up slowly and limits the COMP pin voltage and therefore the PWM duty cycle. In the event of a fault as determined by  $V_{CC}$  undervoltage, line undervoltage (UVLO), or second-level current limit, the output gate drivers are disabled and the soft-start capacitor is fully discharged. When the fault condition is no longer present a soft-start sequence is initiated. Following a second-level current limit detection (CS2), the soft-start current source is reduced to 1  $\mu$ A until the first output pulse is generated by the PWM comparator. The current source returns to the nominal 20- $\mu$ A level after the first output pulse (approximately 1 V at the SS pin).

### 7.3.11 Thermal Protection

Internal thermal shutdown circuitry is provided to protect the integrated circuit in the event the maximum junction temperature is exceeded. When activated, typically at 165°C, the controller is forced into a low-power standby state with the output drivers and the bias regulator disabled. The device restarts after the thermal hysteresis (typically 25°C). During a restart after thermal shutdown, the soft-start capacitor is fully discharged and then charged in the low-current mode (1  $\mu$ A) similar to a second-level current limit event. The thermal protection feature is provided to prevent catastrophic failures from accidental device overheating.

## 7.4 Device Functional Modes

The LM5025 active clamp voltage mode PWM controller has six functional modes. The modes transition diagram is shown in [Figure 12](#).

- UVLO Mode
- Soft-Start Mode
- Normal Operation Mode
- Cycle-by-Cycle Current Limit Mode
- Hiccup Mode
- Thermal Shut Down Mode

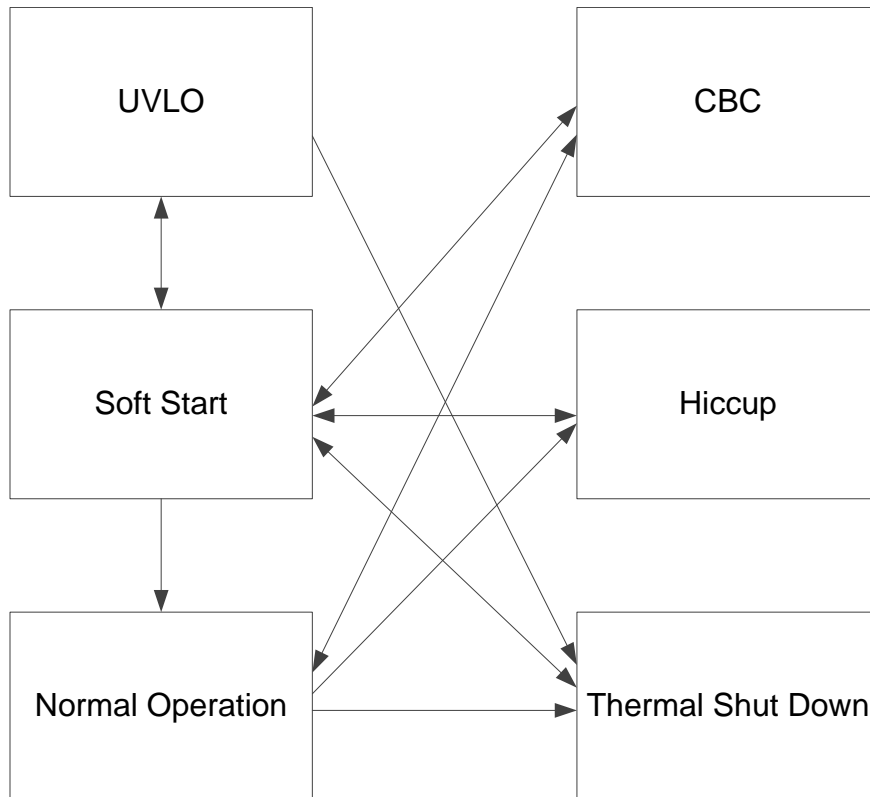

**Figure 12. Functional Mode Transition Diagram**



## 8 Application and Implementation

---

### NOTE

Information in the following applications sections is not part of the TI component specification, and TI does not warrant its accuracy or completeness. TI's customers are responsible for determining suitability of components for their purposes. Customers must validate and test their design implementation to confirm system functionality.

---

### 8.1 Application Information

The LM5025 PWM controller contains all of the features necessary to implement power converters using the active clamp and reset technique. This section provides design guidance for a typical active clamp forward converter design. An actual application schematic of a 36-V to 78-V input, 3.3-V, 30-A output active clamp forward converter is also provided in [Figure 21](#).

### 8.2 Typical Application

[Figure 13](#) shows a simplified schematic of an active clamp forward power converter.

Power converters based on the forward topology offer high-efficiency and good power-handling capability in applications up to several hundred Watts. The operation of the transformer in a forward topology does not inherently self-reset each power switching cycle, a mechanism to reset the transformer is required. The active clamp reset mechanism is presently finding extensive use in medium-level power converters in the 50 W to 200 W range.

The forward converter is derived from the Buck topology family, employing a single modulating power switch. The main difference between the topologies is the forward topology employs a transformer to provide input and output ground isolation and a step down or step up function.

Each cycle, the main primary switch turns on and applies the input voltage across the primary winding. The transformer turns the voltage to a lower-level on the secondary side. The clamp capacitor along with the reset switch reverse biases the transformer primary each cycle when the main switch turns off. This reverse voltage resets the transformer. The clamp capacitor voltage is  $V_{IN} / (1-D)$ .

The secondary rectification employs self-driven synchronous rectification to maintain high-efficiency and ease of drive.

Feedback from the output is processed by an amplifier and reference, generating an error voltage, which is coupled back to the primary side control through an opto-coupler. The LM5025 voltage mode controller pulse width modulates the error signal with a ramp signal derived from the input voltage. Deriving the ramp signal slope from the input voltage provides line feed-forward, which improves line transient rejection. The LM5025 also provides a controlled delay necessary for the reset switch.

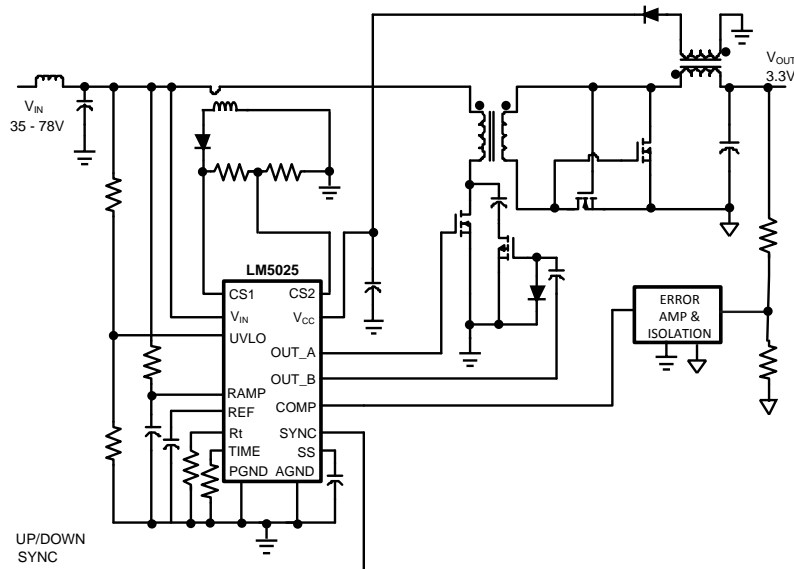
**Typical Application (continued)**

**Figure 13. Simplified Active Clamp Forward Power Converter**
**8.2.1 Design Requirements**

This typical application provides an example of a fully-functional power converter based on the active clamp forward topology in an industry standard half-brick footprint.

The design requirements are:

- Input: 36 V to 78 V (100-V peak)
- Output Voltage: 3.3 V
- Output Current: 0 A to 30 A
- Measured Efficiency: 90.5% at 30 A, 92.5% at 15 A
- Frequency of Operation: 230 kHz
- Board Size: 2.3 × 2.4 × 0.5 inches
- Load Regulation: 1%
- Line Regulation: 0.1%
- Line UVLO, Hiccup Current Limit

**8.2.2 Detailed Design Procedure**

Before the controller design begins, the power stage design must be completed. This section describes the calculations needed to configure the LM5025 controller to meet the power stage design requirements.

**8.2.2.1 Oscillator**

The desired switching frequency  $F$  is set by a resistor connected between  $R_T$  pin and ground. The resistance value  $R_T$  is calculated from [Equation 1](#):

$$R_T = (5725/F)^{1.026}$$

where

- $F$  is in kHz and  $R_T$  in k $\Omega$ .

(1)

## Typical Application (continued)

### 8.2.2.2 Soft-Start Ramp Time and Hiccup Interval

The soft-start ramp time and hiccup interval is programmed by a capacitor ( $C_{SS}$ ) on the SS pin to ground. The soft-start ramp time is determined by comparing the SS pin voltage with COMP pin voltage. When the SS voltage is less than COMP voltage, the COMP voltage is clamped by SS voltage. The PWM duty is limited by the clamped COMP voltage, so that soft-start can be achieved. The first PWM pulse is generated after COMP voltage reaches 1 V. So the soft-start ramp time of the output voltage can be estimated by [Equation 2](#):

$$T_{SS}(\text{ms}) = C_{SS}(\text{nF}) \times \frac{V_{SS} - 1\text{V}}{20\mu\text{A}}$$

where

- $V_{SS}$  is the steady state COMP pin voltage. This voltage is determined by the output voltage, voltage divider, and the compensation network. (2)

In hiccup mode, the SS current source is reduced to 1  $\mu\text{A}$ . When the first PWM pulse is generated, the current source switches to 20  $\mu\text{A}$ , and the power supply tries to start up again. The hiccup interval can be calculated by [Equation 3](#):

$$T_{\text{hiccup}}(\text{ms}) = C_{SS}(\text{nF}) \times \frac{1\text{V}}{1\mu\text{A}}$$
 (3)

### 8.2.2.3 Feed-Forward Ramp and Maximum On Time Clamp

An example illustrates the use of the Volt  $\times$  Second Clamp comparator to achieve a 50% duty cycle limit, at 200 KHz, at a 48-V line input: A 50% duty cycle at a 200 KHz requires a 2.5  $\mu\text{s}$  of ON time. At 48-V input the Volt  $\times$  Second product is 120 V  $\times$   $\mu\text{s}$  (48 V  $\times$  2.5  $\mu\text{s}$ ). To achieve this clamp level, see [Equation 4](#) and [Equation 5](#):

$$R_{FF} \times C_{FF} = V_{IN} \times T_{ON} / 2.5\text{V}$$
 (4)

$$48 \times 2.5\ \mu\text{F} / 2.5 = 48\ \mu\text{F}$$
 (5)

Select  $C_{FF} = 470\ \text{pF}$

$R_{FF} = 102\ \text{k}\Omega$

The recommended capacitor value range for  $C_{FF}$  is 100 pF to 1000 pF.

### 8.2.2.4 Dead Times

The magnitude of the overlap and dead time can be calculated as follows in [Equation 6](#) and [Equation 7](#):

$$\text{Overlap Time (ns)} = 2.8 \times R_{SET} - 1.2$$
 (6)

$$\text{Dead Time (ns)} = 2.9 \times R_{SET} + 20$$

where

- $R_{SET}$  in k $\Omega$ , Time in ns (7)

**Typical Application (continued)**

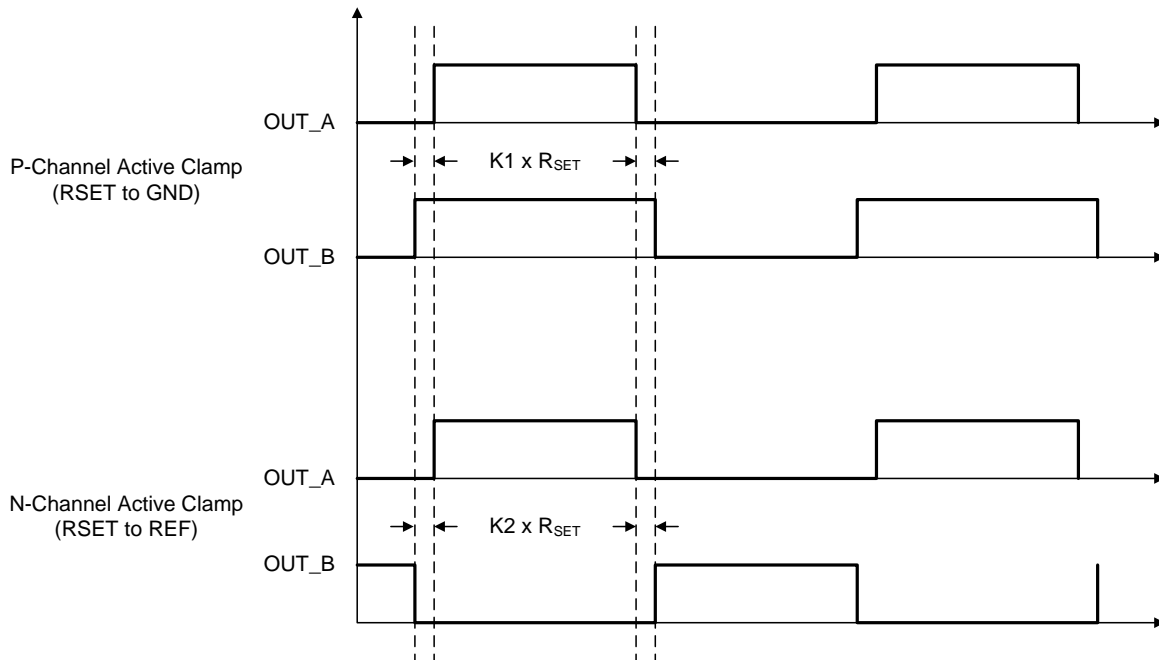

**Figure 14. PWM Outputs**

**Typical Application (continued)**

**8.2.3 Application Curves**

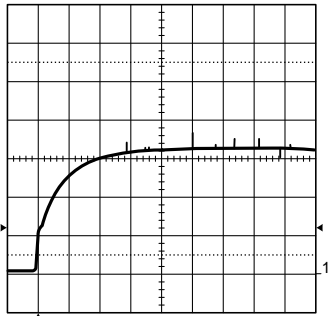

Conditions: input voltage = 48 VDC, output current = 5 A  
Trace 1: output voltage Volts/div = 0.5 V  
Horizontal resolution = 1 ms/div

**Figure 15. Output Voltage During Typical Startup**

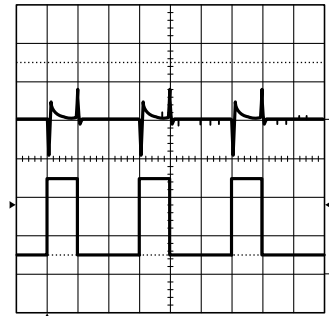

Conditions: input voltage = 48 VDC, output current = 5 A to 25 A  
Trace 1: output voltage Volts/div = 0.5 V  
Trace 2: output current, Amps/div = 10 A  
Horizontal resolution = 1  $\mu$ s/div

**Figure 16. Transient Response**

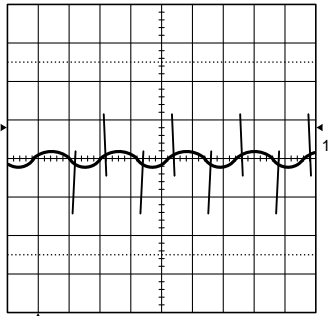

Conditions: input voltage = 48 VDC, output current = 30 A  
Bandwidth limit = 25 MHz  
Trace 1: output ripple voltage Volts/div = 50 mV  
Horizontal resolution = 2  $\mu$ s/div

**Figure 17. Output Ripple**

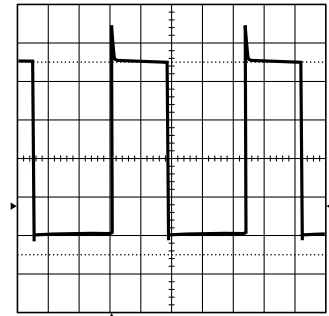

Conditions: input voltage = 38 VDC, output current = 25 A  
Trace 1: Q1 drain voltage Volts/div = 20 V  
Horizontal resolution = 1  $\mu$ s/div

**Figure 18. Drain Voltage**

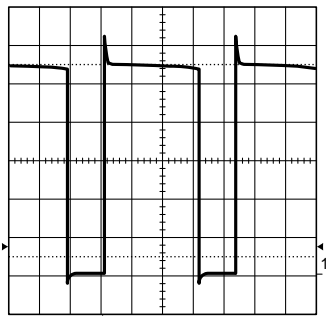

Conditions: input voltage = 78 VDC, output current = 25 A  
Trace 1: Q1 drain voltage Volts/div = 20 V  
Horizontal resolution = 1  $\mu$ s/div

**Figure 19. Drain Voltage**

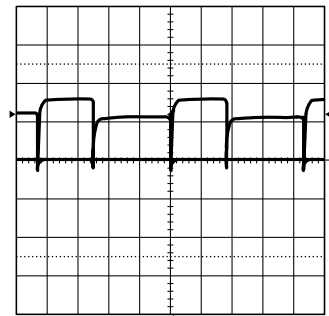

Conditions: input voltage = 48 VDC, output current = 5 A  
Synchronous rectifier, Q3 gate Volts/div = 5 V  
Trace 1: synchronous rectifier, Q3 gate Volts/div = 5 V  
Trace 2: synchronous rectifier, Q5 gate Volts/div = 5 V  
Horizontal resolution = 1  $\mu$ s/div

**Figure 20. Gate Voltages of the Synchronous Rectifiers**

**Typical Application (continued)**
**8.2.4 System Example**

Figure 21 shows an application circuit with 36-V to 78-V input and 3.3-V, 30-A output capability.

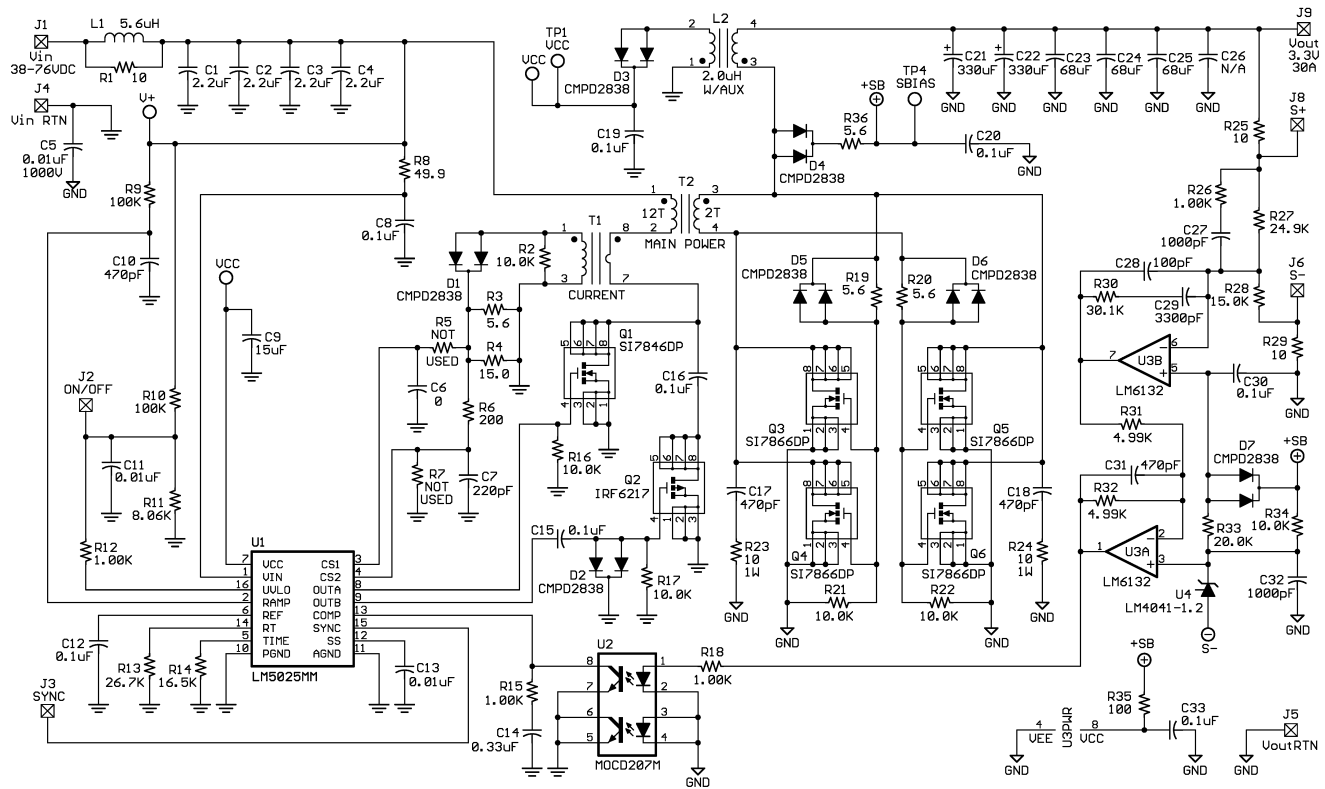

**Figure 21. Application Circuit**

## 9 Power Supply Recommendations

$V_{CC}$  pin is the power supply for the device. There must be a 0.1- $\mu\text{F}$  to approximately 100- $\mu\text{F}$  capacitor directly from  $V_{CC}$  to ground. REF pin must be bypassed to ground as close as possible to the device using a 0.1- $\mu\text{F}$  capacitor.

## 10 Layout

### 10.1 Layout Guidelines

- Connect two grounds PGND (power ground) and AGND (analog ground) directly as device ground ICGND. The connection must be as close to the pins as possible.
- If there are multiple PCB layers and there is an inner ground layer, use two vias or one big via on GND and connect them to the inner ground layer (ICGND).
- The power stage ground PSGND should be separated with the ICGND. PSGND and ICGND should be connected at a single point close to the device.
- The bypass capacitors to the  $V_{CC}$  pin and REF pin should be as close as possible to the pins and ground (ICGND).
- The filtering capacitors connected to CS1 and CS2 pins should have connections as short as possible to ICGND; if an inner ground layer is available, use vias to connect the capacitors to the ground layer (ICGND).
- The resistors and capacitors connected to the timing configuration pins should be as close as possible to the pins and ground (ICGND).

### 10.2 Layout Example

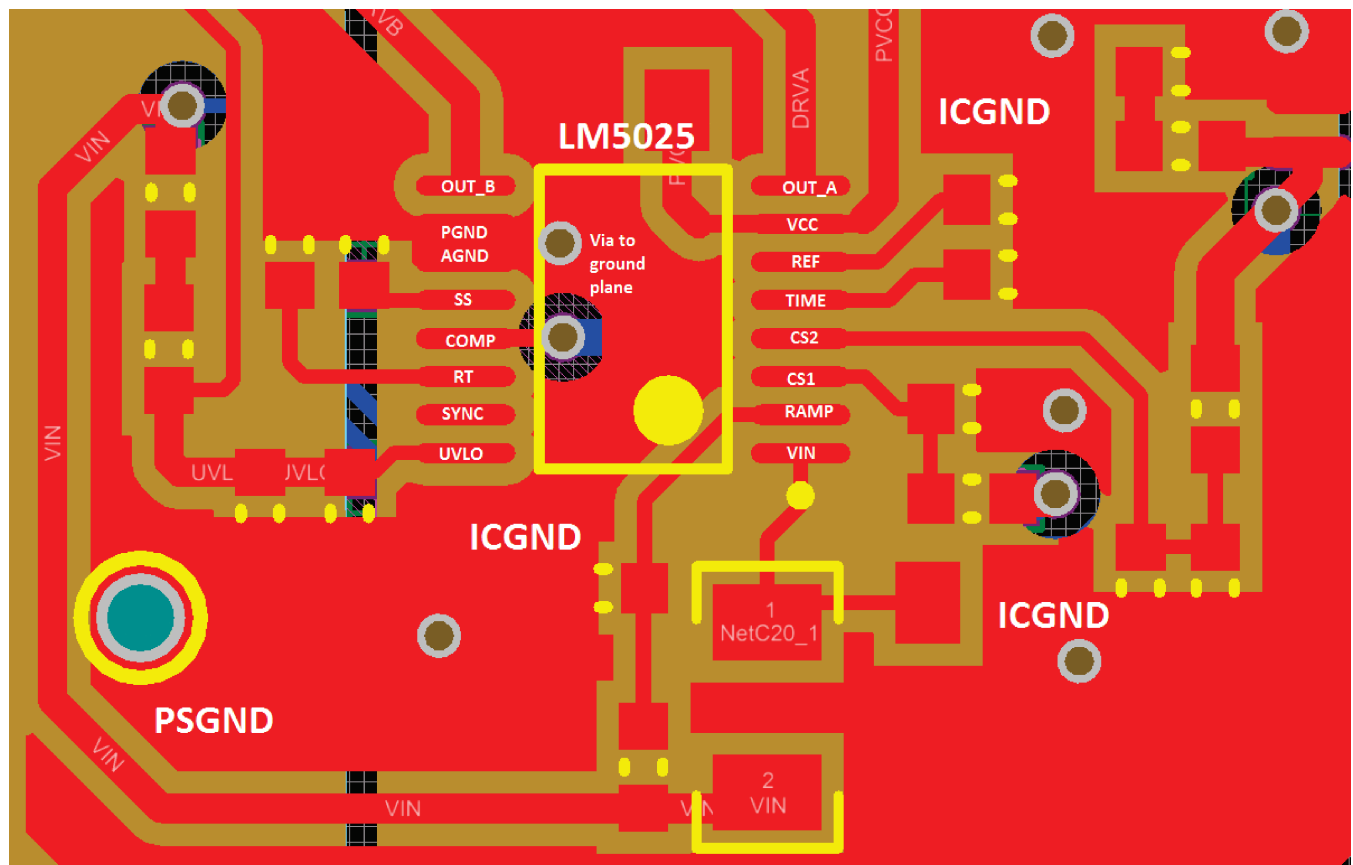

Figure 22. LM5025 Layout Recommendation

## 11 Device and Documentation Support

### 11.1 Documentation Support

#### 11.1.1 Related Documentation

For related documentation, see the following:

- *LM5025 Isolated Active Clamp Forward Converter Ref Design User Guide*, [SNVU096](#)

### 11.2 Community Resources

The following links connect to TI community resources. Linked contents are provided "AS IS" by the respective contributors. They do not constitute TI specifications and do not necessarily reflect TI's views; see TI's [Terms of Use](#).

**TI E2E™ Online Community** *TI's Engineer-to-Engineer (E2E) Community*. Created to foster collaboration among engineers. At [e2e.ti.com](#), you can ask questions, share knowledge, explore ideas and help solve problems with fellow engineers.

**Design Support** *TI's Design Support* Quickly find helpful E2E forums along with design support tools and contact information for technical support.

### 11.3 Trademarks

E2E is a trademark of Texas Instruments.

All other trademarks are the property of their respective owners.

### 11.4 Electrostatic Discharge Caution



These devices have limited built-in ESD protection. The leads should be shorted together or the device placed in conductive foam during storage or handling to prevent electrostatic damage to the MOS gates.

### 11.5 Glossary

[SLYZ022](#) — *TI Glossary*.

This glossary lists and explains terms, acronyms, and definitions.

## 12 Mechanical, Packaging, and Orderable Information

The following pages include mechanical, packaging, and orderable information. This information is the most current data available for the designated devices. This data is subject to change without notice and revision of this document. For browser-based versions of this data sheet, refer to the left-hand navigation.



**PACKAGING INFORMATION**

Orderable Device	Status (1)	Package Type	Package Drawing	Pins	Package Qty	Eco Plan (2)	Lead finish/ Ball material (6)	MSL Peak Temp (3)	Op Temp (°C)	Device Marking (4/5)	Samples
LM5025MTC/NOPB	ACTIVE	TSSOP	PW	16	92	RoHS & Green	NIPDAU   SN	Level-1-260C-UNLIM	-40 to 125	LM5025 MTC	<a href="#">Samples</a>
LM5025MTCX/NOPB	ACTIVE	TSSOP	PW	16	2500	RoHS & Green	NIPDAU   SN	Level-1-260C-UNLIM	-40 to 125	LM5025 MTC	<a href="#">Samples</a>
LM5025SD/NOPB	ACTIVE	WSON	NHQ	16	1000	RoHS & Green	SN	Level-1-260C-UNLIM	-40 to 125	5025SD	<a href="#">Samples</a>

(1) The marketing status values are defined as follows:

**ACTIVE:** Product device recommended for new designs.

**LIFEBUY:** TI has announced that the device will be discontinued, and a lifetime-buy period is in effect.

**NRND:** Not recommended for new designs. Device is in production to support existing customers, but TI does not recommend using this part in a new design.

**PREVIEW:** Device has been announced but is not in production. Samples may or may not be available.

**OBSOLETE:** TI has discontinued the production of the device.

(2) **RoHS:** TI defines "RoHS" to mean semiconductor products that are compliant with the current EU RoHS requirements for all 10 RoHS substances, including the requirement that RoHS substance do not exceed 0.1% by weight in homogeneous materials. Where designed to be soldered at high temperatures, "RoHS" products are suitable for use in specified lead-free processes. TI may reference these types of products as "Pb-Free".

**RoHS Exempt:** TI defines "RoHS Exempt" to mean products that contain lead but are compliant with EU RoHS pursuant to a specific EU RoHS exemption.

**Green:** TI defines "Green" to mean the content of Chlorine (Cl) and Bromine (Br) based flame retardants meet JS709B low halogen requirements of <=1000ppm threshold. Antimony trioxide based flame retardants must also meet the <=1000ppm threshold requirement.

(3) MSL, Peak Temp. - The Moisture Sensitivity Level rating according to the JEDEC industry standard classifications, and peak solder temperature.

(4) There may be additional marking, which relates to the logo, the lot trace code information, or the environmental category on the device.

(5) Multiple Device Markings will be inside parentheses. Only one Device Marking contained in parentheses and separated by a "-" will appear on a device. If a line is indented then it is a continuation of the previous line and the two combined represent the entire Device Marking for that device.

(6) Lead finish/Ball material - Orderable Devices may have multiple material finish options. Finish options are separated by a vertical ruled line. Lead finish/Ball material values may wrap to two lines if the finish value exceeds the maximum column width.

**Important Information and Disclaimer:** The information provided on this page represents TI's knowledge and belief as of the date that it is provided. TI bases its knowledge and belief on information provided by third parties, and makes no representation or warranty as to the accuracy of such information. Efforts are underway to better integrate information from third parties. TI has taken and continues to take reasonable steps to provide representative and accurate information but may not have conducted destructive testing or chemical analysis on incoming materials and chemicals. TI and TI suppliers consider certain information to be proprietary, and thus CAS numbers and other limited information may not be available for release.

In no event shall TI's liability arising out of such information exceed the total purchase price of the TI part(s) at issue in this document sold by TI to Customer on an annual basis.

**TAPE AND REEL INFORMATION**

**QUADRANT ASSIGNMENTS FOR PIN 1 ORIENTATION IN TAPE**

\*All dimensions are nominal

Device	Package Type	Package Drawing	Pins	SPQ	Reel Diameter (mm)	Reel Width W1 (mm)	A0 (mm)	B0 (mm)	K0 (mm)	P1 (mm)	W (mm)	Pin1 Quadrant
LM5025MTCX/NOPB	TSSOP	PW	16	2500	330.0	12.4	6.95	5.6	1.6	8.0	12.0	Q1
LM5025MTCX/NOPB	TSSOP	PW	16	2500	330.0	12.4	6.95	5.6	1.6	8.0	12.0	Q1
LM5025SD/NOPB	WSO	NHQ	16	1000	178.0	12.4	5.3	5.3	1.3	8.0	12.0	Q1

## TAPE AND REEL BOX DIMENSIONS



\*All dimensions are nominal

Device	Package Type	Package Drawing	Pins	SPQ	Length (mm)	Width (mm)	Height (mm)
LM5025MTCX/NOPB	TSSOP	PW	16	2500	367.0	367.0	35.0
LM5025MTCX/NOPB	TSSOP	PW	16	2500	853.0	449.0	35.0
LM5025SD/NOPB	WSON	NHQ	16	1000	210.0	185.0	35.0



4220204/A 02/2017

NOTES:

- All linear dimensions are in millimeters. Any dimensions in parenthesis are for reference only. Dimensioning and tolerancing per ASME Y14.5M.
- This drawing is subject to change without notice.
- This dimension does not include mold flash, protrusions, or gate burrs. Mold flash, protrusions, or gate burrs shall not exceed 0.15 mm per side.
- This dimension does not include interlead flash. Interlead flash shall not exceed 0.25 mm per side.
- Reference JEDEC registration MO-153.

# EXAMPLE BOARD LAYOUT

PW0016A

TSSOP - 1.2 mm max height

SMALL OUTLINE PACKAGE



LAND PATTERN EXAMPLE  
EXPOSED METAL SHOWN  
SCALE: 10X



SOLDER MASK DETAILS

4220204/A 02/2017

NOTES: (continued)

- 6. Publication IPC-7351 may have alternate designs.
- 7. Solder mask tolerances between and around signal pads can vary based on board fabrication site.

# EXAMPLE STENCIL DESIGN

PW0016A

TSSOP - 1.2 mm max height

SMALL OUTLINE PACKAGE



SOLDER PASTE EXAMPLE  
BASED ON 0.125 mm THICK STENCIL  
SCALE: 10X

4220204/A 02/2017

NOTES: (continued)

8. Laser cutting apertures with trapezoidal walls and rounded corners may offer better paste release. IPC-7525 may have alternate design recommendations.
9. Board assembly site may have different recommendations for stencil design.

NHQ0016A

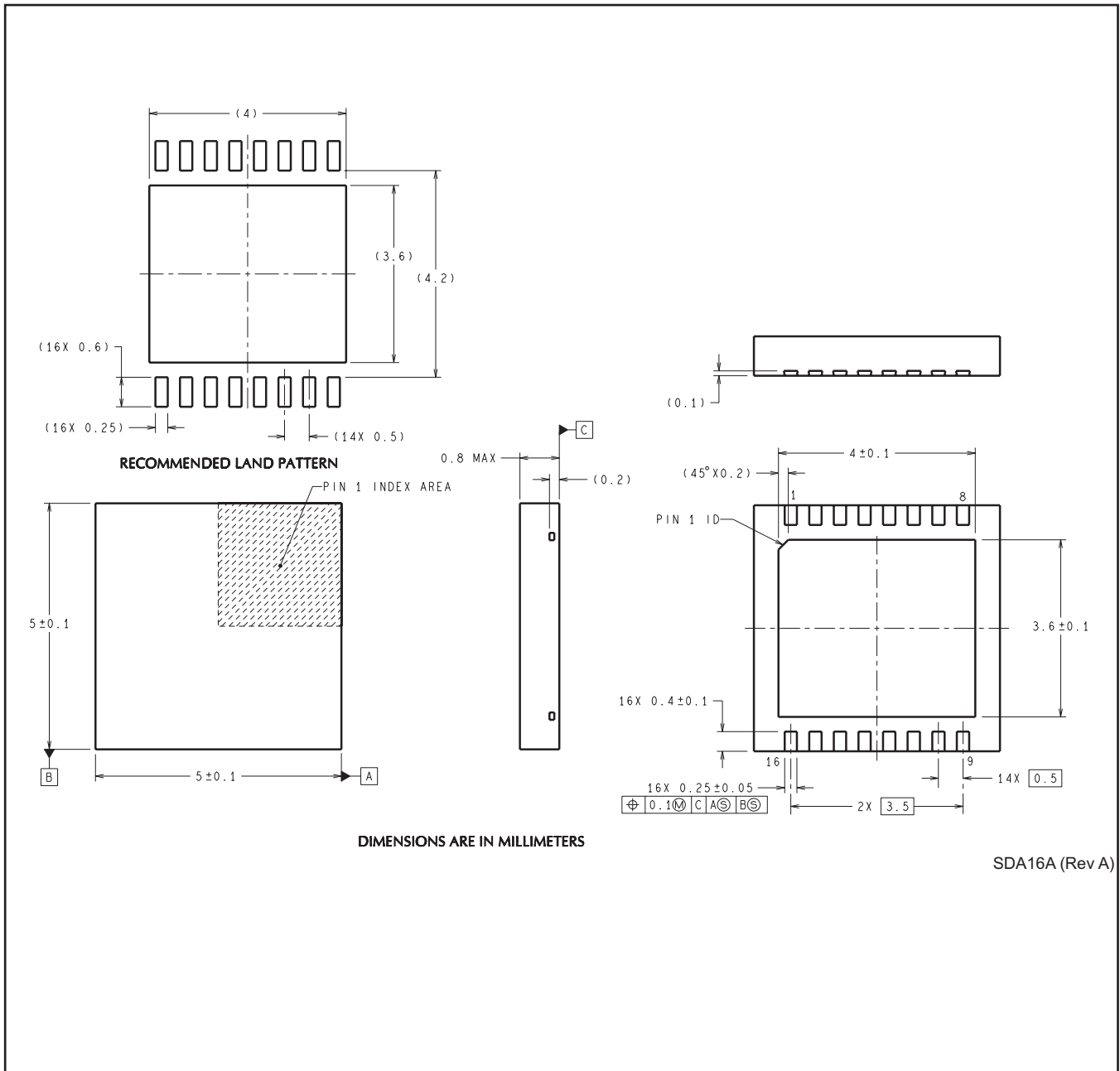



## IMPORTANT NOTICE AND DISCLAIMER

TI PROVIDES TECHNICAL AND RELIABILITY DATA (INCLUDING DATASHEETS), DESIGN RESOURCES (INCLUDING REFERENCE DESIGNS), APPLICATION OR OTHER DESIGN ADVICE, WEB TOOLS, SAFETY INFORMATION, AND OTHER RESOURCES "AS IS" AND WITH ALL FAULTS, AND DISCLAIMS ALL WARRANTIES, EXPRESS AND IMPLIED, INCLUDING WITHOUT LIMITATION ANY IMPLIED WARRANTIES OF MERCHANTABILITY, FITNESS FOR A PARTICULAR PURPOSE OR NON-INFRINGEMENT OF THIRD PARTY INTELLECTUAL PROPERTY RIGHTS.

These resources are intended for skilled developers designing with TI products. You are solely responsible for (1) selecting the appropriate TI products for your application, (2) designing, validating and testing your application, and (3) ensuring your application meets applicable standards, and any other safety, security, or other requirements. These resources are subject to change without notice. TI grants you permission to use these resources only for development of an application that uses the TI products described in the resource. Other reproduction and display of these resources is prohibited. No license is granted to any other TI intellectual property right or to any third party intellectual property right. TI disclaims responsibility for, and you will fully indemnify TI and its representatives against, any claims, damages, costs, losses, and liabilities arising out of your use of these resources.

TI's products are provided subject to TI's Terms of Sale ([www.ti.com/legal/termsofsale.html](http://www.ti.com/legal/termsofsale.html)) or other applicable terms available either on [ti.com](http://ti.com) or provided in conjunction with such TI products. TI's provision of these resources does not expand or otherwise alter TI's applicable warranties or warranty disclaimers for TI products.

Mailing Address: Texas Instruments, Post Office Box 655303, Dallas, Texas 75265  
Copyright © 2020, Texas Instruments Incorporated